

**Silverliner IV 92-Day Inspection
Procedures and Forms**

This Page Intentionally Left Blank.



**Southeastern Pennsylvania Transportation Authority
Periodic Inspection and Maintenance Record (per 49CFR229.23)
Silverliner IV MU Locomotives**

--

Date: _____ **Location:** _____ **Vehicle No.** _____

PERIODIC INSPECTION MASTER SIGN OFF SHEET

Job	Pg	Description	Forms Used	Form Page	PI Manual	Technician Signature	Emp. No.
E-1	2	Interior Inspection	<i>PI-1012 Interior Inbound PI-1015 Electric Sliding Door Emer. Release Test</i>	1 2	Section 1		
E-2	5	Cab Signal System & Event Recorder Inspection	<i>PI-1014 Cab Signal Inspection</i>	3	Section 2		
E-3	11	Auxiliary Group Inspection	<i>PI-1016 Auxiliary Inspection PI-1017 Air Comp/MA Resistor Inspection</i>	4 5	Section 3		
E-4	24	Rectifier/Main Group Inspection	<i>PI-1018 Battery Inspection PI-1019 Rect/Main Group Inspection</i>	6 7	Section 4		
E-5	30	Undercar Inspection	<i>PI-1020 Underfloor Electrical PI-1021 Traction Motor Inspection, Minimum Brush Lengths PI-1022 Brush & Commutator Report</i>	8 9 10	Section 5 & Section 6		
E-6	53	Roof & Pantograph	<i>PI-1024 Roof Inspection Report PI-1037 Electrical Repairs</i>	11 12	Section 7		
E-7	53	HVAC Inspection	<i>PI-1035 HVAC Inspection</i>	13	Section 3		
M-1	54	Wheels, Mechanical Equipment & Safety Appliances	<i>PI-1025 Mechanical Inspection PI-1026 Wheel Inspection Report PI-1027 Defect Report Mechanical</i>	15 16 17	Section 8		
M-2	56	Air Brake Inspection	<i>PI-1028 Air Inspection Report PI-1029 Defect Report Air Brake</i>	18 19	Section 9		
M-3	60	Interior Mechanical Inspection	<i>PI-1030 Interior Inspection Report PI-1031 Defect Report Interior PI-1032 Destination Signs</i>	20 21 22	Section 10		
M-4	63	Lubrication and Oil Sampling	<i>PI-1033 Gear Unit Inspection PI-1034 Air Compressor Inspection</i>	23 24	Section 11		
E/M	-	Mods and Projects	<i>PI-1036 Modifications & Projects</i>	25	ECN/SMI		

Remarks:

Maintenance Manager's Signature: _____

Director's Signature: _____



Southeastern Pennsylvania Transportation Authority
Periodic Inspection and Maintenance Record (per 49CFR229.23)
Silverliner IV MU Locomotives

JOB E1 AND FORMS PI-1012 & PI-1015

TOOLS REQUIRED

MU Control Handles	MU Coach Key	Flashlight	Flat Blade Screwdriver
Phillips Screwdriver	Digital VOM	Amp Meter	Manometer
Test Light with Part #1828 Light Bulb			

REFERENCE DOCUMENTS

Silverliner IV Heavy Maintenance Manuals
Silverliner IV Troubleshooting Manuals
Silverliner IV Electrical Schematics
SAB-1 Air brake and Train Handling Instructions
SEPTA Railroad Consolidated Safety Manual
ET-001 Electric Traction Instructions



**USE CAUTION!
HIGH VOLTAGE
MAY BE PRESENT!**

DISCUSSION

The technician(s) who performs this inspection must be a qualified member of the class or craft designated to perform this work and be thoroughly familiar with all aspects of MU locomotive operation under live operating conditions and must have completed training in railroad safety. All procedures must be performed under proper Blue Signal Protection and in accordance with all SEPTA, NORAC, and FRA safety regulations and procedures.

The purpose of the Inbound Inspection is to check those items which can only be checked with vehicle powered by live catenary under normal operating conditions and to find and record defects for repair immediately or when time and manpower permit. The inspector is responsible for checking all items listed; taking all measurements required; for checking car history since the last periodic inspection; checking for completed Vehicle Condition Reports (VCR) also called MP-11 forms and recording the results of the inspection on the inspection [Form PI-1012](#), and on VMIS Work Order Form when appropriate. The Inspector's initials and signature indicate that the items listed have been checked, tested or measured and if found defective, notations have been made as indicated. Turn in all open and completed VMIS Work Order forms for any repairs required or completed. Group open work request items together and make note of them on the inspection forms.

Whenever practical, check that trainlined control signals produce the desired response in adjacent coupled vehicles. These may include power tests, braking, communication, and door control signals.

Review the vehicle history prior to beginning the inspection and make note of any areas that the history indicates may need attention. Enter the date, location and vehicle number on the inspection forms and follow the procedure as outlined. When the inspection is completed, turn in all paperwork to immediate supervisor or group leader for processing.

LIGHTING

Check all lighting areas listed, replacing burned out light bulbs as needed. Pay particular attention that lighting is adequate in passageways, over and around entrances and steps. Make note of any fixtures that remain inoperable after bulbs have been replaced and complete a VMIS Work Order for any defects found whether repaired or not. Make repairs when practicable. Turn in VMIS Work Orders for work completed and for open work request items. Record all findings on [Form PI-1012](#).

COMMUNICATIONS

Test the Radio and the Public Address System if equipped -- Note that on Silverliner IV Married Pairs, the A-end microphone when activated should NOT activate the microphone in the operator's cab. Check Communication Buzzers and buttons, and Horns. Radio must transmit and receive on all channels. Communication buzzers must be working and clearly audible to the operator. Communication buzzer buttons must work from all locations. Public Address announcements and Communication Buzzers must be audible in any adjacent coupled vehicles. The horn must have two distinct tones and sound loud and clear when activated. Note any defects or deficiencies as previously instructed.



Southeastern Pennsylvania Transportation Authority
Periodic Inspection and Maintenance Record (per 49CFR229.23)
Silverliner IV MU Locomotives

Make repairs when practicable. Turn in VMIS Work Orders for work completed and for open work request items. Record all findings on [Form PI-1012](#).

HEAT, VENTILATION, AND AIR CONDITIONING

With a control plug in place, test ventilation, heat, air conditioning, and Cab Heaters and defrosters based on weather conditions noting that comfortable temperatures are maintained in the passenger and operator compartments. Record findings on [Form PI-1012](#). Check to see that HVAC systems are also activated on adjacent coupled vehicles. Make repairs when practicable. Turn in VMIS Work Orders for work completed and for open work request items. Record all findings on [Form PI-1012](#).

DOORS AND DOOR CONTROLS

Test all electrically operated doors individually and trainlined. Check to see that all doors operate from the local control panel and also that doors respond to signals from remote locations and adjacent coupled vehicles when applicable. Check the operation of the door override pedal from the operator's compartment. Pay particular attention to operator-controlled safety lockouts. Check for any condition that causes the door motor to stay energized while the door is not able to open or close. Include all of the following checks and/or tests:

- (A) Individual Doors
 - A Check the operation of the Crew Switches at #1 and #4 doors:
 - (a) Doors must open easily when emergency release lever is activated.
 - B Test door operation with trap door in the up position. The door should not attempt to close.
 - C Door Operator Panel Inspection.
 - (a) Check to see that the panel is secured, and that no hardware is missing or loose.
 - (b) Make sure that the motor is secured firmly to the panel.
 - (c) Make sure that the door does not oscillate when open or closed.
- (B) Train Line Testing.
 - A Check to see that doors open in both directions from each door operation control panel.
 - B Make sure that Train Line Open/Close Buttons on one side do not operate doors on the other side.
- (C) All Cars — Check to see that Parlor Doors close automatically when Master Controller Handle is moved to the P-1 Power Position.

Transformer Fan Current should average 1.7-2.2 amps and Transformer Pump Current should average 5.7-6.2 amps.

Note any defects. Make repairs when practicable. Turn in VMIS Work Orders for work completed and for open work request items. Record all findings on [Form PI-1012](#).

ADDITIONAL INSTRUCTIONS

On Silverliner IV MU's, check the Performance and Fault Indication panel for indications of tripped protective relays or excessive wheelslip indications, then reset the panel indicators and counters. Record any fault condition noted. Test the lamps and replace bulbs as needed. Measure and record Wheelslip Speed Sensor resistance.

Test each vehicle for power and direction using procedures appropriate for the vehicle being tested and make sure that each pair of motors in each truck is powering up in the proper direction.

With the vehicle running and air brakes, handbrakes and chocks applied, walk around the vehicle examining each piece of rotating equipment for unusual noise, vibration, appearance, or operation. Listen and watch for air leaks. Make note of burn smells. Ensure that the air compressor is running and cycling properly and check the operation of the air conditioning units under the vehicle when appropriate. Record findings in the spaces provided on [Form PI-1012](#) and record defects on a VMIS Work Order.



Southeastern Pennsylvania Transportation Authority
Periodic Inspection and Maintenance Record (per 49CFR229.23)
Silverliner IV MU Locomotives

Check for excessive noise and/or vibration inside the vehicle from blower motors, air compressor, air conditioning evaporator units, etc.

TEST FOR D.C. GROUNDS

IMPORTANT: use a test light first to check for grounds by attaching one lead to car body and the other lead to first B+ and then B-. Experience has shown that the best test light bulb to use is a GE #1828 bulb, Storeroom lot/class #59-2936/R7 (alternate lot/class #59-3041-WYO). There are two sockets available: (1) is lot/class #59-4303-R1 and (2) is lot/class #59-4351-R1.

If the Test Light lights, do not attempt to use your VOM to read the amperage level or damage to the VOM may result. An 1828 bulb will light dimly at about six (6) milliamps at 38 VDC. Higher amperage will cause a brighter light. If the light bulb blows, use a higher wattage bulb for your initial trouble shooting.

If, when you touch either the B+ or B-, you do not have a bright light to an even glow on the element of the bulb, but you do notice an arc on the terminal, use a VOM set to the highest DC amperage scale to check the ground intensity. (Remember that most meters cannot read greater than two (2) amps or 2000 Milliamps on the DC amperage scales.) Retest at B+ and B- lowering the DC milliamp scale as needed to obtain an accurate reading.

When reporting a DC ground on a VMIS Work Order, the polarity of the ground is determined as follows:

- a. If the ground is noted between the B+ terminal and car body ground, a negative ground exists.
- b. If the ground is noted between the B- terminal and car body ground, a positive ground exists.

Please note that you can read voltage with a VOM even though the ground lights a Test Light. When reporting grounds, always indicate the voltage, polarity and amperage, if obtainable. If you have decided not to read amperage because the ground does light the Test Light, make that indication on the VMIS Work Order.

GR AND RGR TEST

Use the following sequence to test the main propulsion system ground protection circuitry.

DROP THE PANTOGRAPH. Failure to drop the pantograph will expose the technician to life-threatening high voltage.

1. Locate the Main Transformer Filter Fuses located in the "A" Contactor box of the Rectifier Group.
2. Place a jumper from F1, F2, or F3 fuse holder clip to car body.
3. Raise the pantograph.
4. Check that GR (Ground Relay) and RGR (Reduced-power Ground Relay) are both tripped. Record your findings on [Form PI-1016](#). List any defects on a VMIS Work Order.
5. DROP THE PANTOGRAPH. Failure to drop the pantograph will expose the technician to life-threatening high voltage.
6. Reset RGR and GR.
7. Remove the jumper and then raise the pantograph.

Make sure that all breakers are on. These include breakers that are inside the lockers in the passenger compartment and vestibule as well those in the cabinets under the vehicle. Record your findings on [Form PI-1016](#). List any defects on a VMIS Work Order.

Check to see if any fault lights are lit or protective relays tripped. Record your findings on [Form PI-1016](#). List any defects on a VMIS Work Order. Check for the presence of voltage on the Battery Buss with LVTB --- Low Voltage Control Breaker (or Auxiliary Control Breaker) off.

Check the visual condition and operation of the Air Compressor making sure that no fluid or air leaks are visible. Record your findings on [Form PI-1016](#). List any defects on a VMIS Work Order.

Check the operation of all Silverliner IV Battery Chargers. Record your findings on [Form PI-1016](#). List any defects on a VMIS Work Order.

Check to see if the Siemens PTC cab signal ERS Failure Light is on or off. Record your findings on [Form PI-1016](#). List any defects on a VMIS Work Order.

Complete the inspection form and turn it in with any VMIS Work Orders and MP-11 Vehicle Condition Reports completed by T & E personnel.



Southeastern Pennsylvania Transportation Authority
CAB SIGNAL SYSTEM AND EVENT RECORDER INSPECTION
Silverliner IV MU Locomotives (Inspection per 49CFR
229.23)

JOB E2 AND FORM PI-1014

TOOLS REQUIRED

Control Plug/Master Key	MU Coach Key	Cab Signal Locker Key
Simpson 260 Meter	Digital VOM	½" Wrench
Cab Signal Test Box	Stopwatch	Flat Blade Screwdriver
Cab Signal Test Loop	Roadway Worker Arm Band	Tape Measure

REFERENCE DOCUMENTS

System Functional Description (SFD-5664)

PROCEDURE

Enter the date and location of the inspection. Record the vehicle number and what type of inspection. Record the cab signal test box calibration due date and SEPTA serial number. Check On Board Computer and Event Recorder Date and Time and compare with the actual date and time. If the OBC and Event Recorder Date and Time differs with the actual Date and Time by more than 2 minutes, adjust accordingly.

Measure the track receiver heights from the rail head to the bottom of the receiver bar cover and verify height is 6-9". Check the track receivers are mounted 0-2" in-board from the center of the rail to the outside end of the receiver bar. If the track receiver measurements are not within the specifications, corrections must be made before proceeding further in this procedure and before the vehicle is returned to service. Improper height or alignment may be the result of damage to the track receiver mounting bracket, mis-adjustment of the track receivers on the mounting bracket, or improper vehicle running floor height. Visually inspect ATC receiver coils, PTC scanner antenna, PTC CTV box, roadway worker antennas, junction boxes, speed sensor wiring, cables, and connectors for signs of physical damage and secure mounting.

1. TEST FOR GROUNDS

- A Turn the ATC and PTC Circuit Breakers OFF.
- B Measure the Insulation Resistance with a Simpson 260 meter.
- C Turn the knob to R X 10,000.
- D Connect the Negative lead to Carbody.
- E Connect the Positive lead to each of these 19 points in turn:

ATC 32V (+), ATC 32V (-), ATC Tach (+), ATC Tach (-), ATC Penalty (+), ATC Penalty (-), F-Receiver Coil (Test Point 1), F-Receiver Coil (Test Point 2), No Motion (+), No Motion (-), PTC 32V(+), PTC 32V (-), PTC Tach (+), PTC Tach (-), PTC Penalty (+), PTC Penalty (-), R-Receiver Coil (Test Point 1), R-Receiver Coil (Test Point 2), EXT I/O 32 Test Point (+), EXT I/O 32 Test Point (-).

(Insulation Resistance must be greater than 1MΩ).
- F Turn ATC and PTC Circuit Breakers ON.

2. MEASURE AND RECORD VOLTAGES

- A Measure ATC Battery Input Voltage is 26-47VDC.
- B Measure ATC Power Supply Voltage is 31-33VDC.
- C Measure ATC Penalty Voltage is 28-33VDC.
- D Measure EXT I/O 32 Test Point Voltage is 28-33VDC.



Southeastern Pennsylvania Transportation Authority
CAB SIGNAL SYSTEM AND EVENT RECORDER INSPECTION
Silverliner IV MU Locomotives (Inspection per 49CFR
229.23)

- E Measure PTC Battery Input Voltage is 26-47VDC.
- F Measure PTC Power Supply Voltage is 31-33VDC.
- G Measure PTC Penalty Voltage is 28.

Note: If PTC is cut-out (shadow mode), it must be cut-in to check PTC Penalty Voltage.

3. F-END ROADWAY WORKER

- A Turn on the roadway worker arm band by pressing the power switch.
- B Check that the arm band does not alert.
- C Activate the F-End Cab.
- D Check that the arm band alerts.
- E Turn off the roadway worker arm band.

4. F-END ATC DEPARTURE TEST

- A . Charge the brake system and place the handle in suppression for the duration of the test.
- B Turn the departure test key CCW to ATC Departure Test and leave it on for the duration of the test.
- C All Indicators on the ADU will illuminate, Signal Aspect will be white and both speed displays show 188 for approximately 5 seconds.

ATC Test 1

- D The signal Aspect will go to a CLEAR(270/270 Code Rate) with an MAS of 100mph and an actual speed of 5mph displayed on the ADU.
- E The Alerter Indicator will flash, and the alarm will sound and must be Acknowledged within 6 seconds to avoid penalty.

ATC Test 2

- F The aspect remains CLEAR with an MAS of 100mph, however, the actual speed increases to 105mph to create an overspeed condition. The overspeed must be acknowledged within 4.6 seconds to avoid penalty.

ATC Test 3

- G The Aspect remains CLEAR with an MAS of 100mph, however, the actual speed decreases to 99mph.

ATC Test 4

- H The Aspect remains CLEAR with an MAS of 100mph, however, the actual speed decreases to 0mph.
- I The Aspect downgrades to RESTRICTING with an MAS of 20mph.

- J DO NOT ACKNOWLEDGE THE DOWNGRADE-Wait 4.6 seconds for the penalty brake application and brakepipe to discharge.

ATC Test 5

- K Acknowledge alarm within 4.6 seconds.

ATC Test 6

- L A code rate of CLEAR(270/270) is initiated below the detectable threshold for 5 seconds.



Southeastern Pennsylvania Transportation Authority
CAB SIGNAL SYSTEM AND EVENT RECORDER INSPECTION
Silverliner IV MU Locomotives (Inspection per 49CFR
229.23)

ATC Test 7

M "PASSED" should be displayed on the ADU Message Display. Turn the departure test key to OFF.

5. F-END PTC DEPARTURE TEST

- A Charge the brake system and place the handle in suppression for the duration of the test.
- B Turn the departure test key CW to PTC Departure Test and leave it on for the duration of the test.
- C All Indicators on the ADU will illuminate, Signal Aspect will be white and both speed displays show 188 for approximately 5 seconds.

PTC Test 1

- D The Train type will be shown on the ADU message display. The correct train type for all SEPTA passenger service is type B, all work equipment is type E. If correct type is displayed, Acknowledge, if a different type is displayed, abort the test and configure using a PTU with PTCVIEW software.
- E Press ACKNOWLEDGE to continue.

PTC Test 2

- F The system tests the scanner antenna for up to 15 seconds.

PTC Test 3

- G Wait for the Positive Train Stop penalty brake application and brakepipe to discharge.

PTC Test 4

- H Acknowledge the Penalty.

PTC Test 5

- I The system tests the MCP Data Radio for up to 15 seconds.

PTC Test 6

- J "PASSED" should be displayed on the ADU Message Display. Turn the departure test key to OFF.

6. F-END LOW CURRENT SIGNAL PICKUP LEVEL

- A Place the cab signal test box induction loop under the ATC receiver coils.
- B Set the cab signal test box to a single 100Hz carrier with a "270" code rate.
- C Increase the 100Hz current until the bottom green LED on the Decoder Board is lit solid and a CAB SPEED 60 aspect is displayed on the ADU.
- D Test all 100Hz code rates. If any of the code rates flip, increase the signal current and retest each of the code rates. Minimum signal pickup level for 100Hz carrier code rates must be between 1.5 and 1.8 amps. If the pickup is not within the specified range, follow the "[Low Current Signal Pickup Level Adjustment](#)" procedure below.
- E Increase the 100Hz carrier signal current to 2.0 amps.
- F Set the cab signal test box for dual carrier "270/270" code rate and increase the 250Hz carrier signal current until the bottom yellow LED on the Decoder Board is lit solid and a CLEAR aspect is displayed on the ADU.
- G Test all dual carrier code rates. If any of the code rates flip, increase the 250Hz carrier signal current and retest each of the code rates. Minimum signal pickup level for 250Hz carrier code rates must be between



Southeastern Pennsylvania Transportation Authority
CAB SIGNAL SYSTEM AND EVENT RECORDER INSPECTION
Silverliner IV MU Locomotives (Inspection per 49CFR
229.23)

0.8 and 1.0 amps. If the pickup limits are not within the specified range, follow the "Low Current Signal Pickup Level Adjustment" procedure below.

7. LOW CURRENT SIGNAL PICKUP LEVEL ADJUSTMENT

F-End

100 Hz Carrier

- A Remove the OBC LED Nameplate by loosening the thumb screws.
- B Set the cab signal test box to "NO CODE" and set the single 100Hz steady current at 1.65A.
- C Set the cab signal test box to a 100Hz carrier with a "270" code rate.
- D Loosen the 100Hz "front-end gain" Potentiometer lock nut on the 100Hz Filter/Amplifier PCB and turn the potentiometer counterclockwise to decrease the sensitivity below the threshold of detection by the system. At this point the bottom green LED light will extinguish.
- E Turn the 100Hz "front-end gain" potentiometer clockwise until the bottom green LED on the Decoder Board is lit solid and a CAB SPEED 60 aspect is displayed on the ADU.
- F Tighten the 100 Hz Filter/Amplifier Gain Adjustment Potentiometer locking nut to prevent the adjustment from moving inadvertently due to vehicle shock and vibration. Do not damage the locking nut by over tightening it.

Note: Tightening the lock nut can cause the adjustment to increase as the lock nut is turned clockwise. Hold the potentiometer in position while tightening the lock nut.

- G This completes the calibration adjustment of the 100Hz Filter/Amplifier.
- H Increase the 100Hz steady state current to 2.0A.
- I Set the cab signal test box to a single 100Hz Carrier with a "270" code rate.
- J Verify Cab Speed 60 aspect is displayed on the ADU.

250 Hz Carrier

- K Set the cab signal test box to "NO CODE" and set the 250Hz steady current to 0.90 Amps.
- L Set the portable cab signal test box to a Dual carrier with a Dual "270" code rate.
- M Loosen the 100Hz "front-end gain" Potentiometer lock nut on the 250Hz Filter/Amplifier PCB and turn the potentiometer counterclockwise to decrease the sensitivity below the threshold of detection by the system. At this point the bottom yellow LED light will extinguish.
- N Turn the 250Hz "front-end gain" potentiometer clockwise until the bottom yellow LED on the Decoder board is lit solid and a CLEAR aspect is displayed on the ADU.
- O Tighten the 250 Hz Filter/Amplifier Gain Adjustment Potentiometer locking nut to prevent the adjustment from moving inadvertently due to vehicle shock and vibration. Do not damage the locking nut by over tightening it.
- P Note: Tightening the lock nut can cause the adjustment to increase as the lock nut is turned clockwise. Hold the potentiometer in position while tightening the lock nut.

8. EVENT RECORDER FAULT LIGHT

Check Inbound Inspection form to see if the Event Recorder Fault Light was on. If the event recorder fault light was on, download the fault log and determine the cause. Repair before placing the vehicle back into service.



Southeastern Pennsylvania Transportation Authority
CAB SIGNAL SYSTEM AND EVENT RECORDER INSPECTION
Silverliner IV MU Locomotives (Inspection per 49CFR
229.23)

9. ODOMETER

Record the digital odometer reading.

10. OBC DATA LOGGER BATTERY CHECK

- A Open PTCView program on laptop computer.
- B Go to Tools.
- C Select Battery Check.

11. WHEEL SIZE

- A In PTCView program select Real Time Monitor.
- B Go to Help and select Revision/Config Info.
- C Check wheel size of wheels #5 and #6 and compare the smallest value to the value shown in PTCView. If wheel size differs by $\frac{3}{4}$ " or greater follow procedure below.

12. PROCEDURE TO CHANGE WHEEL SIZE IN ATC/PTC SYSTEM

- A Open PTCView program.
- B Select Configure PTC/ATC.
- C Enter the password: CONFIG.
- D When the "PTC/ATC Configuration" window pops-up, apply parameters.
 - a. "Vehicle Type".
 - b. "Vehicle Number" — Type in the vehicle number.
 - c. Max Vehicle Speed — 100MPH.
 - d. "Wheel Diameter" — Enter new wheel size.
 - e. "Front Cab Active Offset" measured from the front end (F-End) of the vehicle.
60 for SL IV Single and married pair.
 - f. "Rear Cab Active Offset" measure from the rear end (R-End) of the vehicle.
30 for SL IV Single.
120 for SL IV married pair.
- E Press the ATC "SEND" button. When the system accepts the new configuration, the
- F "CONFIRM" button will become active.
- G Verify the data displayed is still correct, press the ATC "CONFIRM" button.
- H Press the PTC "SEND" button. When the system accepts the new configuration, the "CONFIRM" button will become active.
- I Verify the data displayed is still correct, press the PTC "CONFIRM" button.
- J Press the "OK" button.



Southeastern Pennsylvania Transportation Authority
CAB SIGNAL SYSTEM AND EVENT RECORDER INSPECTION
Silverliner IV MU Locomotives (Inspection per 49CFR
229.23)

13. SOFTWARE REVISION

- K Open PTCView.
- L Go to Help.
- M Select Revision/Config Info.
- N Record software revision levels and determine if revision level is correct.

14. CUT-OUT SEALS

Inspect ATC and PTC cut-out switches are properly set and sealed.

Code Rate Chart

Cycles Per Minute (CPM)	
100Hz / 250Hz Code Rate(s)	SEPTA Signal Aspect
0 / 0	Restricted
75 / 0	Approach
75 / 75	Approach
120 / 0	Approach Medium
270 / 0	Cab Speed 60
120 / 120	Cab Speed 80
270 / 270	Clear
180 / 0	Clear
180 / 180	Clear

15. RECORD SERIAL NUMBERS:

- A CTV.
- B Antennas.
- C ID Module.



Southeastern Pennsylvania Transportation Authority
AUXILIARY GROUP INSPECTION INSTRUCTIONS
Silverliner IV MU Locomotives (Inspection per 49CFR229.23)

JOB E3 AND FORMS PI-1016 & PI-1017

TOOLS REQUIRED

Digital VOM

Approved Megohmmeter

Standard Hand Tool Set

REFERENCE DOCUMENTS

Silverliner IV Heavy Maintenance Manuals
Silverliner IV Troubleshooting Manuals
Silverliner IV Electrical Schematics



*****Danger High Voltage May Be Present*****
Use Caution While Inspecting or Repairing This Equipment

DISCUSSION

The technician(s) who performs this inspection must be a qualified member of the class or craft deemed qualified to perform this work and be thoroughly familiar with all aspects of MU locomotive operation under live operating conditions and must have completed training in railroad safety. All procedures must be performed under proper Blue Signal Protection and in accordance with all SEPTA, NORAC, and FRA safety regulations and procedures.

The Auxiliary Group Inspection groups several underfloor electrical tests and inspections together under one heading. This part of the Periodic Inspection procedure is usually performed by one technician. The Auxiliary Group contains equipment that controls the auxiliary functions of Silverliner IV Electric MU Locomotives including but not limited to the generation of 230 Volt - 60 Hz - 3 Ø current, the components that support this function, and that are powered by this output. The technician who performs this inspection may also inspect items in other areas as indicated by the itemized list on the applicable forms.

In addition to completing Forms [PI-1016](#), [PI-1017](#), and [PI-1018](#), the technician should complete a VMIS Work Order for any significant repairs completed and any items still needing attention but not repaired by the end of the shift. Inform immediate supervisor of any significant defects as soon as discovered. Give completed paperwork to immediate supervisor or follow the location's procedures for processing completed paperwork.

Form PI-1016

1. Visually inspect the Air Compressor Breaker (ACB) for physical damage. On some Silverliner IV Cars, the Air Compressor Breaker and overload interlock are located in the Main Group. Check for loose connections and make sure the breakers operate mechanically. Test the trip mechanism is equipped. Make repairs and adjustments as needed and record findings on [Form PI-1016](#).
2. Visually inspect all breakers in the Auxiliary Control Group for physical damage. Check for loose connections and make sure the breakers operate mechanically. Test the trip mechanism is so equipped.
3. Visually inspect the Blower Motor Alternator MAC-1 and MAC-2 Contactors and manually test operation. Replace burnt or worn contact tips. Make repairs and adjustments as needed and record findings on [Form PI-1016](#).
4. Visually inspect the Air Compressor ACC Contactor and manually test operation. Replace burnt or worn contact tips. Make repairs and adjustments as needed and record findings on [Form PI-1016](#).
5. Visually inspect the Equipment Fan EFC Contactor and manually test operation. Replace burnt or worn contact tips. Make repairs and adjustments as needed and record findings on [Form PI-1016](#).
6. Visually inspect all other contactors in the Auxiliary Control Group and manually test operation. Replace burnt or worn contact tips. Make repairs and adjustments as needed and record findings on [Form PI-1016](#).



Southeastern Pennsylvania Transportation Authority
AUXILIARY GROUP INSPECTION INSTRUCTIONS
Silverliner IV MU Locomotives (Inspection per 49CFR229.23)

7. Manually test the Transformer Pump Failure (TPF) relay for proper operation. Test the circuit electrically for proper operation. Inspect for physical wear, damage and loose connections. Manually test the Overspeed and Over-voltage (OSR and OVR) protective relays and inspect for physical wear, damage and loose connections. Make repairs and adjustments as needed and record findings on [Form PI-1016](#).
8. Inspect the Load Application Relay (LAR) for physical wear, damage and loose connections. Test manually and electrically for proper operation. Make repairs and adjustments as needed and record findings on [Form PI-1016](#).
9. Inspect all overload relays in the Auxiliary Control Group for physical wear, damage and loose connections. Manually test the trip and reset mechanism. Check that the proper heater element is installed. Make repairs and adjustments as needed and record findings on [Form PI-1016](#).
10. Visually inspect and manually test all other relays in the Auxiliary Control Group for proper operation, physical wear, damage or loose connections. Make repairs and adjustments as needed and record findings on [Form PI-1016](#).
11. Check for proper operation of all Fault Lights in the Auxiliary Control Group. Replace bulbs as needed. Make repairs and adjustments as needed and record findings on [Form PI-1016](#).
12. Inspect the Buck-boost (BB) and Potential Measuring (PMR) resistors for defects, wear, damage or loose connections. Remove any dirt or debris build-up. Make repairs and adjustments as needed and record findings on [Form PI-1016](#).
13. Inspect Buck-Boost Transformer for defects, damage, or loose connections. Remove any dirt or debris build-up. Make repairs and adjustments as needed and record findings on [Form PI-1016](#).
14. Inspect and test KM Controller according to GEK-38312 Maintenance Manual Instructions. Test the operation and check the condition of relays, contactors. Test Pilot Motor and inspect commutator and brushes. Clean or replace worn contact tips. Remove any debris from cabinet. Make repairs and adjustments as needed and record findings on [Form PI-1016](#).
15. Using a 1000-volt megohmmeter test the following circuits for insulation integrity: Control Circuit using Test Light; 1500-Volt Main Propulsion Circuit; 600-Volt Auxiliary Power circuit; 220/230 VAC Auxiliary circuit; Traction Motor circuit; Electric Head Cables and Safety Wire; and Dynamic Brake circuit on Silverliner IV cars. Make repairs and adjustments as needed and record findings on [Form PI-1016](#).

17KM54B1 CONTROLLER

SCOPE

This section contains information pertaining to the maintenance, repair, disassembly and reassembly, adjustment and test of the 17KM54B1 controller.

DESCRIPTION

The 17KM54B1 controller is a motor-driven, rotating-cam arrangement which operates electrical switches, to control car speed during dynamic braking. The directional dc pilot motor, powered by battery voltage, drives a reduction gear box and a long cam shaft, which operates both high and low voltage contacts.

The controller also has a notch interlock which assures that the controller, once started, will run to the next notch and will always stop in a notch.

OPERATION

As the pilot motor drives the camshaft, the high and low voltage contacts are operated in a preset sequence. By their operation, traction motor circuits are established,

and dynamic braking current is controlled. Also, low voltage circuits are established to promote required relay and contactor logic. Forward and reverse directions, dynamic braking, and deceleration rates are established or otherwise affected by the operation of the KM controller.

The controller operates over a total of 20 positions (1 through 20). See Fig. 8-6. Positions 1 through 17 are used in braking. Position 17 is used as coast. Positions 18 and 19 are the transfer positions required to separate power and brake operations. Position 20 is the only power position.

The pilot motor has two fields which control the direction of cam rotation. When one field is energized, the motor turns counterclockwise (ccw); when the second field is energized, the motor turns clockwise (cw). The following Pilot Motor Data apply:

Resistance at 25° C (77° F):
 Armature/Incl. Brush 2.75 to 3.37 ohms.



Southeastern Pennsylvania Transportation Authority
AUXILIARY GROUP INSPECTION INSTRUCTIONS
Silverliner IV MU Locomotives (Inspection per 49CFR229.23)

Series Field.....0.63 to 0.77 ohms.

Brush Length:

- New 7/8 in.
- Minimum Permissible..... 3/8 in.

Commutator Diameter:

- New 2 in.
- Minimum Permissible.... 1-7/8 in.

MAINTENANCE AND REPAIR

If a contact unit on the controller is changed, a functional check of the replaced contact should be made to assure proper contact unit operation.

If contact tips show signs of abnormal burning, pitting or melting, make a functional check to determine if the contactors have the proper gap and overlap.

Refer to instructions in TEST section when making a controller functional check.

Cleaning

The following brushes are recommended for removing dirt accumulations from the controller and can be obtained from any paint or hardware store.

1. Tube type, 1/2 in. diameter with three in. bristles.
2. No. 2 oval sash brush.
3. No. 6 round sash brush with handle shortened.

Begin with the top back bar and clean creepage surfaces between contact units. Next, clean the top front bar and the camshaft. Then clean the lower back bar and the lower front bar of the controller. This procedure will prevent cleaned surfaces from becoming contaminated during the cleaning process.

Avoid brushing dirt into bearings or finger rollers by using a one-way brush stroke to sweep dirt from the top back bar toward the front of the controller. Wipe accumulated dirt from the contact tip surfaces, using a clean rag.

Lubrication

Pivot Pins

Lubricate the felt wicks of the contact finger pivot pins and load pawl pivot pins every two years with GE-D50E5B oil or equivalent. Use of oil can P/N 341B798G1 is recommended (see SPECIAL TOOLS section). Be sure to confine the lubricant to the wicks, as excess oil will accumulate dirt and reduce creepage distances.

Notch Interlock

Saturate the felt-wick lubricator, (7) Fig. 8-13, at the interlock pivot points at least once a year. Use GE-D50E5B oil (or equivalent).

NOTE: *Gear box and bearings do not require periodic lubrication.*

ADJUSTMENT AND TEST

Notch Interlock Contact Adjustment.

1. Rotate the controller camshaft to the zero-tolerance position. (Block open all load pawls (except the zero-tolerance load pawl) and the power contact units listed in Table I).
2. With the camshaft turned to zero tolerance position, make sure the roller of the load pawl is resting solidly in the bottom of its cam notch.
3. Loosen locknuts (1), Fig. 8-11.
4. Place a notch interlock gauge 41A285034-P1 on the starwheel, with the roller resting in the concave cut-out. Be sure both surfaces of the gauge are in contact with the starwheel. Adjust the run contact studs until they just touch the movable contact fingers. Use a low-voltage test light to check the contact point of the tips.
5. Adjust the plug contact studs to obtain a gap of 0.015 in. ± 0.005 in. between the studs and the movable contact fingers (6).
6. Tighten locknuts (1) and recheck the contact settings.
7. Remove the gauge and blocks from the controller.

Sequence Test

Perform a systems sequence test, as described in the test instructions for the control group.

Test

Perform the following steps to check the opening and closing points of the contact units whenever it is desirable to see if contact unit operation is acceptable. If any power contacts have been replaced, use this check to test replaced contacts for proper operation. Make a contact unit operational check as follows:

1. Check all contacts and units for alignment of the rollers on the cams and for tightness of all assemblies.
2. Check for excessive friction and/or binding by rotating the controller by hand from stop to stop.
3. Check the break and contact pressure of all fingers.



Southeastern Pennsylvania Transportation Authority
AUXILIARY GROUP INSPECTION INSTRUCTIONS
Silverliner IV MU Locomotives (Inspection per 49CFR229.23)

4. Set notch interlock contacts as described under "Notch Interlock Adjustment" section.

CONTROLLER FUNCTIONAL CHECK (CRITICAL)

Turn the controller by hand through the following positions and check specified fingers for "must overlap" and "must not overlap" conditions. Make sure fingers move freely without binding. To check for a "must overlap" condition, turn the controller, making certain one finger is fully wiped in before the second finger begins to

open. To check for a "must not overlap" condition, turn the controller until one finger is at "tips touch" position, and check second finger for tip separation.

**Approximate Controller Position
Action of Fingers**

5-6	R6 must overlap R7.
9-10	R8 must overlap R9.
9-8	R8 must not overlap R10.

16. Inspect the electric heads on both ends of vehicle. Replace worn or broken springs, contact tips, weatherstripping or other defective components. Make repairs and adjustments as indicated by the following excerpt from GEK-38312 and record findings on [Form PI-1016](#).

INSPECTION AND LUBRICATION

The contact blocks and electrical contacts in the electric portion must be cleaned with one of the agents listed below and should be blown dry with a low-pressure air jet. Air pressure should not exceed 30 psi.

Varsol No.2	No. 1 denatured alcohol (hexane).
VM and P naphtha	No. 30 denatured alcohol.
white kerosene	isobutyl alcohol.
white gasoline	isopropyl alcohol.
methyl alcohol	soap solution with thorough rinsing (most safe).

CAUTION: Only the cleaning agents listed above are permissible for electrical contact cleaning. In particular, the use of chlorinated hydrocarbons must be avoided. If cleaners other than those listed above are used, rapid deterioration of contact housings can result.

Replace all contacts and housings that are cracked, broken, worn excessively, damaged, or in such condition as would result in unsatisfactory operation (open circuits).

Inspect all springs for rust pits, distortion or permanent set and replace where necessary.

Grasp the door with both hands and move downward to open. The door must open and close freely and seal tightly at the top. Any sluggishness or binding must be remedied. The door may be held open with the aid of a door stop tool (Fig. 1).

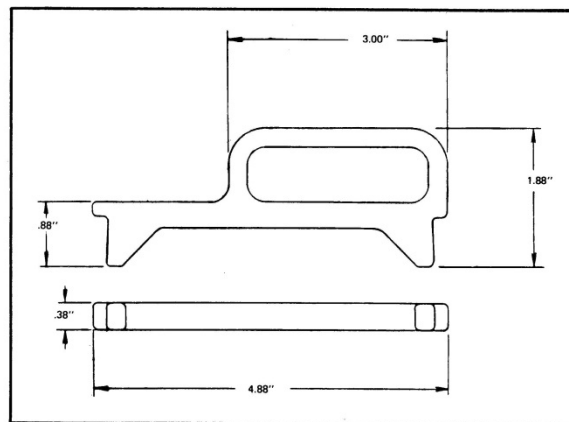

FIG. 1 DOORSTOP TOOL E-16693

With door housing in a position so that the door will move downward when it is forced open, the resistance of the door spring must be measured with a push-pull type resistance indicator (Fig. 2) in the following manner.

By means of resistance indicator, force door downward a distance of 1/2 in. and note resistance to movement as registered on resistance indicator. This must not be less than 70 lb. breakaway and 50 to 60 lb. at 1/2 in. The maximum breakaway should not exceed 100 lb.

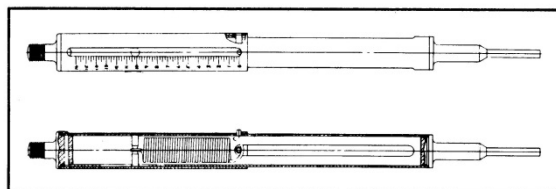

FIG. 2 RESISTANCE INDICATOR E-16694



Southeastern Pennsylvania Transportation Authority
AUXILIARY GROUP INSPECTION INSTRUCTIONS
Silverliner IV MU Locomotives (Inspection per 49CFR229.23)

COMPONENT INSPECTION

Table 1 depicts the required action and the correct frequency of such action required to properly maintain the electric portion.

TABLE 1, ELECTRICAL MAINTENANCE

REQUIRED ACTION ON THE CAR	FREQUENCY
Visual Inspection	Daily
1) Condition of door hinges, levers, and cranks (breaks and cracks). 2) Condition of door spring. 3) Check door action and examine for door sealing. 4) Open door. Secure with a 3/16-inch pin through door plunger bush and through door plunger. a) Check condition of front cover gaskets. b) Examine contacts for worn or cracked housing and for contacts out of position. c) Check condition of guide pin and receptacle.	
Cleaning Electric Portion exterior (steam cleaning is acceptable)	Every 18 months
Clean Electric Portion contacts. Use Lubriplate 107 to lubricate lever system wear point i.e., all pin locations, bushings and places that levers and rods enter the body. Inspect daily and measure door spring force. Check manual retraction of the slide frame by moving the handle located under the electric portion toward the rear of the coupler.	
Overhaul in Shop	Every 3 years
Inspect. 1) Check continuity through the electric portion by dogging the coupler. 2) Check door operation by depressing plunger. 3) Measure door spring force. 4) Check operation of door and slide-operated micro-switches.	

[Form PI-1017](#)

On Silverliner IV GE Cars, perform the tests according to the instruction on the form. Remove any dirt or debris build-up. Make repairs and adjustments as needed and record findings on [Form PI-1017](#).

[Form PI-1018](#)

Inspect and test batteries according to the instruction on the form. Remove any dirt or debris build-up. Make repairs and adjustments as needed and record findings on [Form PI-1018](#).



Southeastern Pennsylvania Transportation Authority
RECTIFIER GROUP INSPECTION INSTRUCTIONS
Silverliner IV MU Locomotives (Inspection per 49CFR229.23)

JOB E4 AND FORM PI-1018

ADDITIONAL BATTERY MAINTENANCE INSTRUCTIONS

TOOLS REQUIRED

Digital VOM Hydrometer	Approved Megohmmeter Thermometer	Standard Hand Tool Set
---------------------------	-------------------------------------	------------------------

REFERENCE DOCUMENTS

GE Silverliner IV Heavy Maintenance Instruction Manual GEK-38312 Section 4-4
 American Battery Charging Manual 64051, Rev. 0 dated March 21, 1998
 Silverliner IV Heavy Maintenance Manuals
 Silverliner IV Troubleshooting Manuals
 Silverliner IV Electrical Schematics

DISCUSSION

The technician(s) who performs this inspection must be a qualified member of the class or craft deemed qualified to perform this work and be thoroughly familiar with all aspects of MU locomotive operation under live operating conditions and must have completed training in railroad safety. All procedures must be performed under proper Blue Signal Protection and in accordance with all SEPTA, NORAC, and FRA safety regulations and procedures.

SEPTA MU Locomotives are equipped with Edison Nickel Cadmium Pocket Plate Storage Batteries or an approved equivalent. The caustic electrolyte is handled differently than the electrolyte in standard lead-acid batteries. Observe all published precautions.

WARNING: Caustic Poison

Edison Nickel-Cadmium storage batteries contain liquid caustic potash which is poisonous and corrosive and will burn or injure skin, eyes, and property. Do not take internally or allow to come in contact with one's person or property. In case of accidental personal injury, call a physician and apply the following antidotes:

External: (skin) flush immediately with plenty of water and apply wet compresses of household vinegar or 5% acetic acid solution. Call a physician. Do not apply ointments, oils or salves before treatment by a physician. (Eyes) flush with plenty of water for at least 15 minutes and get immediate medical attention.

Internal: drink vinegar or lemon juice mixed with an equal amount of water and call a physician immediately.

DESCRIPTION

The Nickel-Cadmium Storage Batteries are molded from tinted ACRYLITE MP-20, a rugged transparent plastic material. A high impact resistance and transparency is maintained over a temperature range of -40 F to +180 F with the use of this plastic.

The purpose of the transparency is to permit quick visual inspection of electrolyte levels. The appropriate maximum and minimum levels are indicated by two red lines on opposite sides of each

cell case.

Yellow vent caps, molded of plastic, use a ball type venting system. These caps are removed and replaced by turning them one quarter turn (90 degrees).

Assembled cell cases are interlocked with opposing male and female ribbings which are molded from the top to the bottom of each cell case.

The case is designed so that all the external surfaces are completely perpendicular to give a more rigid



Southeastern Pennsylvania Transportation Authority
RECTIFIER GROUP INSPECTION INSTRUCTIONS
Silverliner IV MU Locomotives (Inspection per 49CFR229.23)

battery assembly.

The simplified construction of Nickel-Cadmium Storage Batteries requires no special tools for their disassembly or assembly in the field. In conjunction with the use of a very light weight case and cover, it also substantially reduces the overall weight of each battery set.

Plate Design and Assembly

Except for color, both the positive and negative plates are alike in outward appearance, and both are constructed on the flatpressed, "ribbon" plate principle.

The positive active material consists principally of nickel hydrate; and the negative active material is an improved cadmium-oxide mixture.

A narrow ribbon strip is used to give added strength to the finished plate. The steel ribbons are first finely perforated with rectangular-shaped perforations, then nickel-plated and annealed.

Under high pressure, the active material is formed into briquettes which are laid in a controlled pattern on the bottom half of the ribbon. The top half of the ribbon is fed into place and the two edges are folded to form a permanent pocket.

A continuous ribbon group is formed by a pressure roll which interlocks, side by side, the required number of ribbons. This basic ribbon group is then cut to the desired length and fitted horizontally into the plate holding components, including steel side frames and header. The individual plate is completed by a final hydraulic pressing and then welded to form a solid, permanent unit.

The individual plates are assembled into complete cell elements by means of standard through-bolt techniques, using standard design components.

Plate separators are made of plastic in a "hairpin" design and run from the bottom of the plate group upward throughout its entire length. Placed at predetermined intervals, they maintain constant, secure positioning of individual plates.

One-piece, plastic edge insulators are used on both side edges of the element assembly. These specially designed insulators assure permanent and positive plate alignment and provide additional rigidity to the element assembly.

This plate assembly technique effectively maintains the insulation of the element under conditions of severe shock or vibration and prevents any internal element failure.

BATTERY CHARGERS

The Silverliner IV MU Cars have been refitted with a Model RT-37.5-37-S1 manufactured by American Battery Charging, Inc. A complete description along with maintenance, troubleshooting and repair instructions is found in American Battery Charging Manual 64051, Rev. 0 dated March 21, 1998.

The charger is powered by three-phase 41VAC from the Low Voltage Power Supply (LVPS). The charger will supply a constant voltage output, nominal 37.5VDC, for recharging the car battery. The charger is a silicon-controlled rectifier type and will charge the battery at a current up to 37 amps. The charging voltage is compensated for the ambient temperature of the batteries. The battery and charger are isolated from the main DC bus when charging. When AC power is lost, a Power MOSFET (transistor) device connects the battery to the main bus and car loads. The MOSFET also disconnects the battery when the discharge end voltage of 27.5V is reached, thereby reducing the battery depth of discharge. The depth of discharge protection is intended to provide enough battery power to restart the vehicle when AC power is restored and to extend the effective life cycle of the batteries.

PROTECTION

- 50A Charger AC Input Circuit Breaker.
- 50A Charger DC Output Circuit Breaker.
- 10A Load DC Circuit Breaker marked Radio Brkr.
- AC and DC Surge Suppressors.
- Soft Start Circuit.

CONTROLS, DISPLAY AND INDICATORS

The battery charger is provided with numerous LEDs for indication of operating status and a remote panel that includes digital DC voltage current meters. A description of the operation of each of these is provided. Many of the LEDs are common to both the charger and the remote panel.



Southeastern Pennsylvania Transportation Authority
RECTIFIER GROUP INSPECTION INSTRUCTIONS
Silverliner IV MU Locomotives (Inspection per 49CFR229.23)

CHARGER STATUS

INPUT HIGH
 OUTPUT HIGH
 OUTPUT LOW
 CURRENT LIMIT
 OVER TEMP
 OVER-TIME SHUTDOWN
 INPUT LOW
 PHASE LOSS
 SENSOR FAULT
 DISCHARGE

LEDs

HOURS

Displays elapsed time up to 9999 hours

Pushbuttons

HOUR RESET OVER TIME TEST OVER TIME RESET LAMP TEST

- Current Limit- Charger is in current limit.
- Over Temp- Heatsink temperature is too high.
- Over-Time Shutdown — Charger in current limit over 10 hrs.
- Input Low- AC input voltage lower than 33-34 VAC.
- Sensor Fault- The temp sensor TS-1 is open or shorted.
- Discharge- The Power MOSFET is on, and the battery is feeding the loads.

DC VOLTS

37.5

INPUT HIGH

OUTPUT HIGH

OUTPUT LOW

CURRENT LIMIT

OVER TEMP

OVER-TIME SHUTDOWN

DC AMPS

6.4

Green Amber Leds

PUSHBUTTONS & HOUR METER

The pushbuttons and hour meter are displayed on Logic Board E3 located on the charger door.

Hour Meter — Hour Meter - Resets the elapsed time meter.

Over Time Test — Press and hold for 3 minutes to check the Over Time circuit.

Over Time Reset — Resets the Over Time circuit once tripped.

Lamp Test – Press to check all LEDs on the logic board E3 and remote panel E4.

The hour meter is active whenever AC power is on and will maintain its hour time display as long as the car battery remains above 8 VDC. If the car battery falls below 8 VDC or is disconnected, the hour reading will be lost. When the battery and car AC power is restored, the timer will restart from zero. The hour meter accumulates time only when the AC power is available and is intended to display operating hours of the charger. The hour meter may be used to determine the elapsed time between events such as problems or alarm conditions.

REMOTE DISPLAY PANEL
STATIC CAUTION

The battery charger contains components that can be damaged by static electric discharge. Static protection is recommended when handling any semiconductor components including PC-boards that included these components. Use static protection when handling the following parts of the battery charger.

- Control Board E1 — Located inside charger on left.
- Logic Board E3 — Located inside charger on door.
- Remote Panel Board E4 — Located inside the remote panel.
- Power MOSFET Q1 — Located towards bottom of the Heatsink.

ALARM LEDs

The Alarm LEDs are displayed on the Logic Board E3 located on the charger door. They are listed below:

- Input High- AC input exceeds 50-51 VAC.
- Output High- DC output exceeds 42-43 VDC.
- Output Low- Charger or Battery less than 30-31 VDC.

Override Switch

A 5-minute override switch is mounted externally from the logic board and charger. This is a momentary switch that can reactivate the Power MOSFET after it has been switched off. The override switch will switch on the Power MOSFET if the car AC power is off, and the battery has already reached the 27.5 VDC but is higher than 19 VDC. The discharge period will be for a period of 5 minutes and then the Power MOSFET will again switch off.

Remote Panel E4

The remote panel contains LEDs and displays which are duplicates of the functions and indicators on the E3 logic board. Remote Panel E4 is driven by signals from



Southeastern Pennsylvania Transportation Authority
RECTIFIER GROUP INSPECTION INSTRUCTIONS
Silverliner IV MU Locomotives (Inspection per 49CFR229.23)

logic board E3. The remote panel also includes a digital DC voltmeter and a DC ammeter. The voltmeter displays the charger/battery voltage, and the ammeter shows the chargers output current.

NORMAL OPERATION

The following graphics show typical displays and status indications of the E3 logic board seen on the charger door during normal but varying operating conditions.

Battery near full charge, car power on.

When car power is available and the battery is near full charge, the charging voltage will be nominally 37.5 VDC (at 77° F) and the charging current is low. All status LEDs should be green.

Battery discharged, car power on.

When car power is available and the battery has been discharged, the charger may be delivering a high current to the battery. The CURRENT LIMIT LED may be activated. The OUTPUT LOW LED may also be activated if the battery has been lower than 30-31 VDC. This will remain activated until approximately 35.0 VDC. All other status LEDs are green.

Charger door

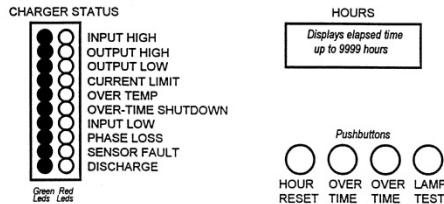

Remote display panel

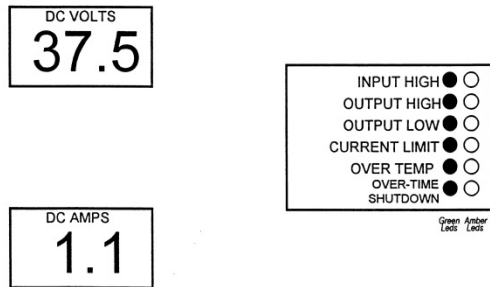

Car power off, battery being discharged.

When car power is not available, the INPUT LOW LED will be activated. The Battery will be discharging, and the DISCHARGE LED will be activated until the battery reached the load-shed point (27-28V). The OUTPUT LOW LED will activate as the battery discharges and the voltage fall to the 30-31V trip point. All other status LEDs should be green.

Charger door

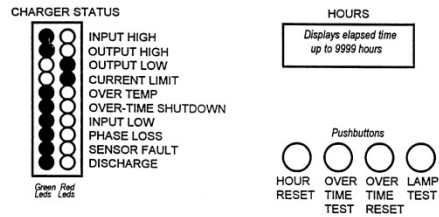

Remote display panel

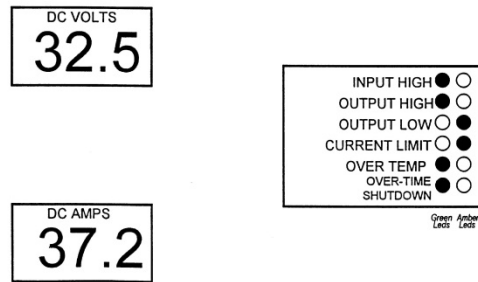



Southeastern Pennsylvania Transportation Authority
RECTIFIER GROUP INSPECTION INSTRUCTIONS
Silverliner IV MU Locomotives (Inspection per 49CFR229.23)

Car power off, battery past load-shed point.

When the car power is not available and the battery has been discharged, the load shed voltage, 27-28V, may have been reached and the Power MOSFET switched off. This disconnects the battery from the main carloads. The OUTPUT LOW LED will be activated as the battery voltage is low. The DISCHARGE LED will not be activated as the discharge has been discontinued. The INPUT LOW LED will remain on until the car power is restored. All other status LEDs should be green.

Charger door

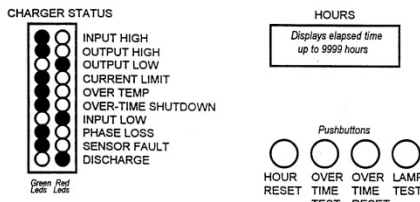

Remote display panel

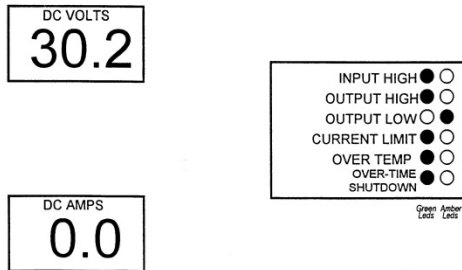

Alarm conditions

The previous sections show typical display status indications for normal operation. All other LEDs are alarm conditions that indicate abnormal operation.

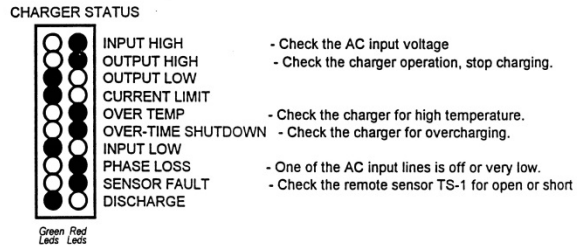

Remote display panel

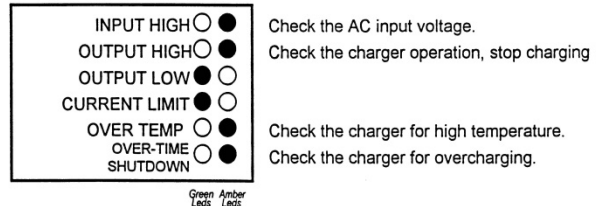

BATTERY MAINTENANCE

I. SPECIFIC GRAVITY TEST

1. Cell-type identification is marked on two sides of each cell. The cell serial number appears on the top of the cover.
2. Agitate cells if water was added.
3. Test each cell using a hydrometer and record reading.
4. Use accompanying chart at the end of this procedure.

II. SPECIFIC GRAVITY INDICATIONS

1. Specific gravity in a Nickel Cadmium cell does not give an indication of the state of charge.
2. Specific gravity as indicated by a hydrometer varies with temperature.



Southeastern Pennsylvania Transportation Authority
RECTIFIER GROUP INSPECTION INSTRUCTIONS
Silverliner IV MU Locomotives (Inspection per 49CFR229.23)

3. As temperature increases the electrolyte becomes less dense, a lower specific gravity will result.
4. As the temperature decreases this will cause the specific gravity to increase.
5. As the battery ages the specific gravity will decrease slowly.
6. If the specific gravity of a cell decreases to 1.160 at 60 degrees F, renewal of the electrolyte is necessary. Disposal must be done in accordance with EPA/DER regulations.
7. See Table #1 for specific gravity indications and Table #3 for electrolyte capacity for cells.

III. CELL VOLTAGE

1. Measure each cell and record voltage.
2. Cell voltage will vary with temperature.
3. See Table #2.
4. Cells that read under 1.00 volt will be scrapped.

IV. BI-ANNUAL PROCEDURE (REMOVE BATTERIES FROM CAR)

1. Perform procedures (I - III) as previously mentioned.
2. Remove the battery intercell connectors and install jumpers (#6 AWG wire with copper clips). This enables the tester to jump each cell out as it reaches the desired cut-off voltage of 1.10 volts.
3. The following term (cycle) means- charge and discharge.
4. The battery is then given at least (2) cycles to determine the capacity as received.
5. Charge the cells at 30 amps for 16 hours followed by a discharge of 30 amps to 1.10 volts per cell, for capacity.
6. Cells that make 180 amp are considered suitable for service.
7. Cells that do not make 180 amp-hours will be subject to the following procedures.

V. CAUTION

1. Do not use tools, hydrometers which have been previously used with lead-acid batteries. They may damage the nickel-cadmium cells.
2. Never allow an exposed flame or spark to come near the cells, when they are charging. A mixture of oxygen and hydrogen are given off and capable of igniting.
3. Do not lay any metal or tools on top of the batteries. This may cause an arc and produce an explosion.
4. Disconnect the load or charging circuits when the batteries are being disconnected or connected.
5. Always have adequate ventilation when charging cells.
6. All filler vent caps should be in place and tight when charging.



Southeastern Pennsylvania Transportation Authority
RECTIFIER GROUP INSPECTION INSTRUCTIONS
Silverliner IV MU Locomotives (Inspection per 49CFR229.23)

TABLE #1: STANDARD CELLS SPECIFIC GRAVITY 1.190-1

Temperature of Electrolyte		Recommended Gravity (Solution at Recommended Levels)	
Degrees F.	Degrees C.	Maximum	Minimum
110	43	1.177	1.147
110	38	1.180	1.150
90	32	1.182	1.152
80	27	1.185	1.155
70	21	1.187	1.157
60	16	1.190	1.160
50	10	1.192	1.162
40	4	1.197	1.167
30	-1	1.200	1.170
20	-7	1.202	1.172
0	-18	1.205	1.175
-10	-23	1.207	1.177
-20	-29	1.210	1.180



Southeastern Pennsylvania Transportation Authority
RECTIFIER GROUP INSPECTION INSTRUCTIONS
Silverliner IV MU Locomotives (Inspection per 49CFR229.23)

TABLE #2: TYPICAL CELL VOLTAGES

Solution Temperature		Volts Per Cell
Degrees Fahrenheit	Degrees Centigrade	
80	27	1.45
70	21	1.47
60	16	1.49
50	10	1.51
40	4	1.53
30	-1	1.55
20	-7	1.57
10	-12	1.59
0	-18	1.61



Southeastern Pennsylvania Transportation Authority
RECTIFIER/MAIN GROUP INSPECTION INSTRUCTIONS
Silverliner IV MU Locomotives (Inspection per 49CFR229.23)

JOB E4 AND FORM PI-1019

TOOLS REQUIRED

Digital VOM

Approved Megohmmeter

Standard Hand Tool Set

REFERENCE DOCUMENTS

Silverliner IV Heavy Maintenance Manuals
Silverliner IV Troubleshooting Manuals
Silverliner IV Electrical Schematics

DISCUSSION

The technician(s) who performs this inspection must be a qualified member of the class or craft deemed qualified to perform this work and be thoroughly familiar with all aspects of MU locomotive operation under live operating conditions and must have completed training in railroad safety. All procedures must be performed under proper Blue Signal Protection and in accordance with all SEPTA, NORAC, and FRA safety regulations and procedures.

The Rectifier/Main Group Inspection groups several underfloor electrical tests and inspections together under one heading. This part of the Periodic Inspection procedure is usually performed by one technician. The Rectifier/Main Group contains equipment that controls the delivery of DC Electrical power to the traction motors as well as the components that control the primary motive vehicle functions.

RECTIFIER CONTROL GROUP -- ALL CARS

1. Power Staging Contactors

A-1, A-2, and A-3 Power Staging Contactors are GE Type CP2BH11 electro-pneumatic devices consisting of the following parts:

Magnet Valve — an electrically operated device that controls air flow to the operating cylinder.

Air Cylinder — provides the force to operate the contactor. Air pressure overcomes a mechanical lever mechanism to close a set of contacts that deliver high voltage electricity to the motoring circuit.

Interlocks — a series of low voltage contacts that operate whenever main contactor operates to provide electrical control signals to motoring control circuits.

Blow Out Coil — sets up a magnetic field which directs the electrical arc, whenever the main contact tips open under load, into the arc chute.

Arc Chute — contains and extinguishes the electrical arc generated whenever the main contact tips open under load.

Shunts — flexible electrical conductors that connect the movable contact tip to the main high voltage bus bar connection.

When electrical power is applied to the contactor magnet valve coil, air flows to the air cylinder and causes the contacts to close. When power is removed from the magnet valve coil, air pressure in the cylinder is exhausted and the contacts open. There are two magnet valves. One magnet valve controls the flow of air to the air cylinder. The second magnet valve does not control air delivery but helps open the contact tips faster. The second magnet valve is energized at the same time as the first and when de-energized helps exhaust air from the operating cylinder more quickly to provide for a quick clean contact tip break.

Refer to GE Heavy Maintenance Instructions GEK-38312, Section 2-9, for detailed maintenance and repair information.



Southeastern Pennsylvania Transportation Authority
RECTIFIER/MAIN GROUP INSPECTION INSTRUCTIONS
Silverliner IV MU Locomotives (Inspection per 49CFR229.23)

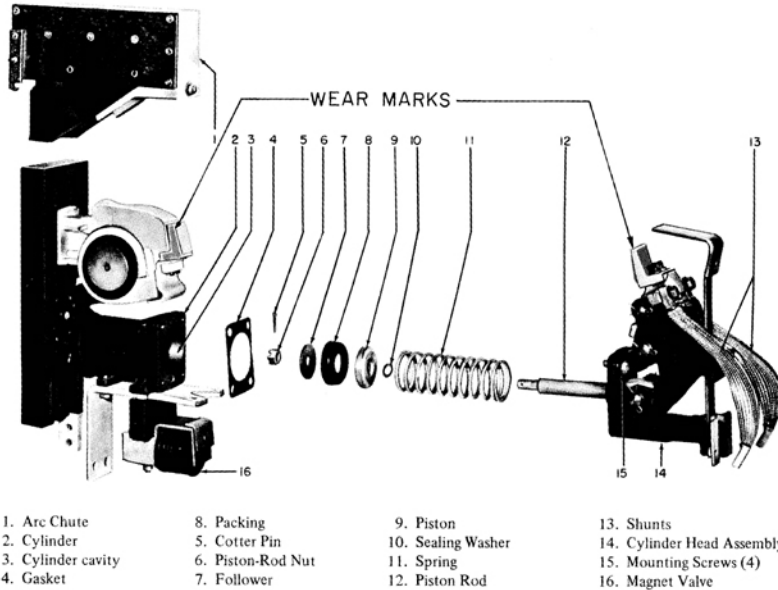

In order to perform this test, there must be at least 70 PSI of control air available to operate the contactors.

Check A-1, A-2, and A-3 contactors by manually operating the magnet valves associated with each one. Check for proper tip alignment. Allowable side-to-side tip misalignment is 1/16" overhang of the movable contact tip on either side of the stationary contact tip. The heels of the contact tips may also have a maximum of 1/16" overhang. One tip may protrude beyond the other by this amount.

Clean or replace the contact tips as needed and look for any loose or broken parts, air leaks or broken or frayed wires attached to the contactors.

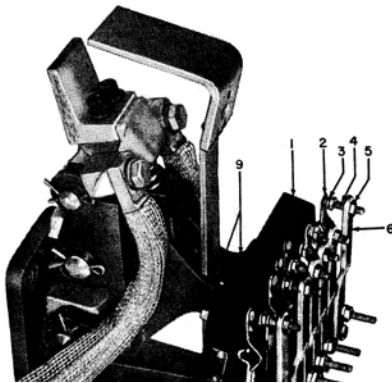

Inspect the contact interlocks. Look for proper operation, proper contact alignment, contact tip condition and wire condition. Burnish contact tips if needed. Repair or replace any defective parts.

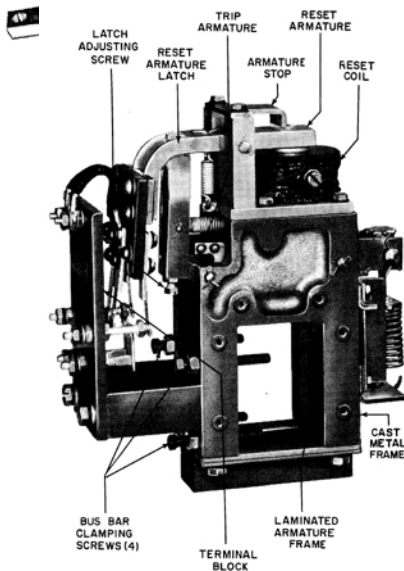

Each power staging contactor is accompanied by a GE Type DB1690 Overload Relay which protects the primary motoring circuit from over-current conditions. Manually test each overload and inspect for proper operation, loose or damaged parts, or loose or frayed wiring. Burnish contact tips if necessary.

Refer to the Heavy Maintenance Manual Section covering the parts you are inspecting if there are questions as to proper operation or proper methods of inspection or repair. Record all findings and minor repairs on [Form PI-1019](#). Record any significant defects and/or repairs on a VMIS Work Order.



Southeastern Pennsylvania Transportation Authority
RECTIFIER/MAIN GROUP INSPECTION INSTRUCTIONS
Silverliner IV MU Locomotives (Inspection per 49CFR229.23)

2. Ignitron Tubes

The Ignitron Tube is a gas-discharge electronic tube. Each tube consists of a pooled-mercury cathode envelope in shock-mounted double-walled steel jacket. An ignitron is additionally equipped with an ignitor that initiates a conducting phase, an anode to receive and pass conducted current to the load circuit, wall mounted thermostats that protect against high temperature. Each vehicle is equipped with two ignitron tubes connected in inverse parallel.

Inspect the Ignitron Tubes or Phase-Controlling SCRs for proper physical condition. (Note that Ignitron Tubes contain liquid mercury. Replacements or repairs must be handled carefully so as to avoid personal or environmental contamination.) Check for tight electrical connections on all wires, cables and buss bars. Clean the surfaces of all heat sinks. Carefully inspect the shock-absorbing mounts (Item #70 in Diagram at left). Replace any that are weak, cracked or broken. Insulating Rubber Boots surround the bottom of each tube and help direct the clean air flow through the tube's cooling fins. Inspect these boots (Items #61 & #81 in diagram), making sure there are no rips, tears or cracks. Replace as needed. See GE Heavy Maintenance Manual GEK-38312, Section 2-6 for more detailed descriptions and additional maintenance and repair information.

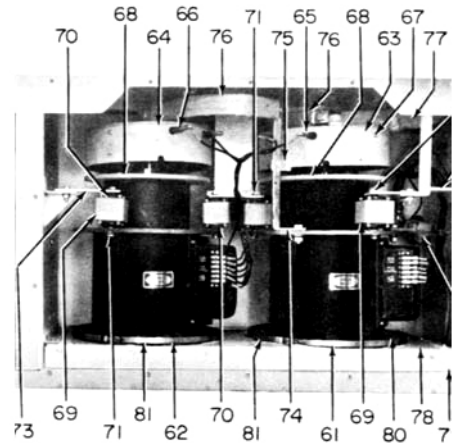

Record the results of your inspection on [Form PI-1019](#).

3. Visually inspect C1-C2-C3-C4 Surge Suppressing Capacitors for oil leaks, dents, or bulges. Capacitors containing PCB's have been outlawed and must be replaced if found. Record the results of your inspection on [Form PI-1019](#). Report any defects or repairs on a VMIS Work Order.
4. Inspect PRP-1, PRP-2, and PRP-3 Propulsion Rectifier Panels for any visible defects, loose or broken wires, or other broken or defective parts. Repair or replace as needed. Check the electrical condition of each diode with a VOM set on a high ohms or diode checking scale. If available, use a meter that has a visual and/or audio continuity feature. Check all the diode readings first in one direction and then the other. Replace any diodes that read or are rated differently than what is standard for each car type. Record findings on [Form PI-1019](#) and defects on a VMIS Work Order.
5. Check Auxiliary Rectifier Panel PRP-4 using the same guidelines described in step 4.
6. Check all fuses with an ohmmeter and replace any that are worn, open or defective. Record findings on [Form PI-1019](#).

AIR COMPRESSOR MOTOR

Inspect all wiring, connections, conduit and pull boxes. Pull gently on wires and wire bundles to check for uncharacteristic looseness or movement. Tighten all terminal board, relay and wire to wire connections while checking the condition of the wiring and the terminals.



Southeastern Pennsylvania Transportation Authority
RECTIFIER/MAIN GROUP INSPECTION INSTRUCTIONS
Silverliner IV MU Locomotives (Inspection per 49CFR229.23)

MAIN CONTROL GROUP

1. Check the tightness of all connections on all relays using a suitable tool. Check relay operation by jumpering a positive control voltage signal to the operating coil. Check the contacts for proper operation, condition, make and break, and proper tension. Burnish as needed with proper burnishing tool. Record the results of your inspection on [Form PI-1019](#) and fill out a VMIS Work Order for any defects or repairs.

DESCRIPTION OF LV66 RELAYS

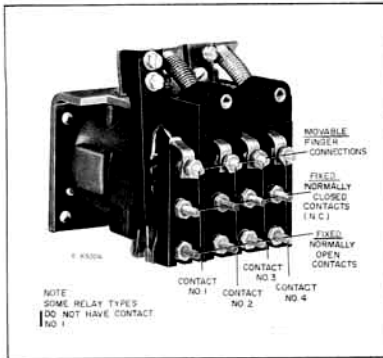

FIG. 11-15. CONTACT IDENTIFICATION. E-8300A

Coil — Electromagnetic device which generates a magnetic field when current is passed through the windings.

Armature — Mechanical lever which is magnetically operated to change the contact tip configuration.

Contact Finger — Movable electrical contact attached mechanically to the armature.

Interlock Contacts — Stationary electrical contact attached to the frame of the relay.

Calibrating Spring — Mechanical adjustment which sets the trip point on the relay. The trip point is specified in amperes at the normal operating voltage.

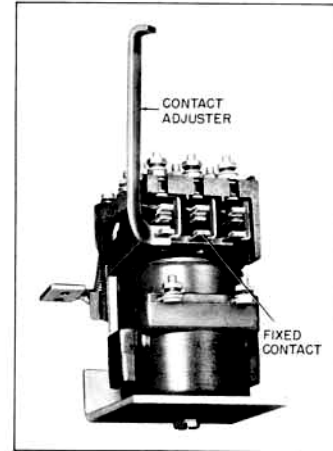
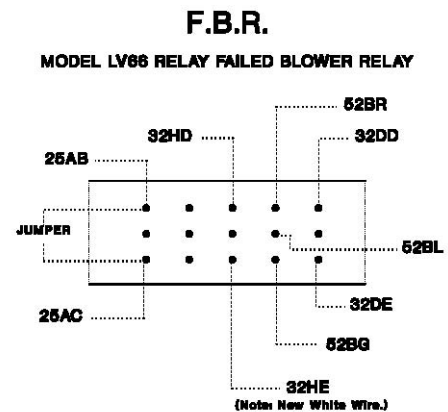

FIG. 11-19. ADJUSTING NORMALLY-OPEN CONTACTS. E-5607A

Refer to GE Heavy Maintenance Manual GEK-38312 Section 2-11 for a more detailed description of operating characteristics and for more in-depth maintenance and repair instructions.

2. Inspect the AM1-AM2-AM3-AM4 and B1-B2 Contactors in the cabinet behind the Main Group. Check operation electrically and mechanically looking for proper contact tip alignment, make and break, and tension. Check tightness of all connections. Inspect and file contact tips if necessary. Check Arc Chutes, interlocks and suppression modules for loose connections, proper operation, etc. Record your findings on [Form PI-1019](#) and write up defects and repairs on a VMIS Work Order.
3. Inspect the reverser from the front and the rear. Tighten any loose connections and check for proper operation. Operate the reverser electrically and manually by activating the reverser magnet valves. Any burn marks or slag on the reverser contacts indicates that the reverser is improperly throwing under a load. Repair contact damage and investigate the cause of the problem. Record findings on [Form PI-1019](#). Enter defects or repairs on a VMIS Work Order.
4. Perform a propulsion sequence test using the Sequence Test Gun. This test may also be performed by operating the car in a normal fashion from the Master Controller. Place a jumper on the normally open contact terminals where wires 32HD and 32HE are attached. (See diagram) One person must operate the control handles while another inspects to see that the proper relays and contactors are picked up in all positions and in both directions. Use the Silverliner IV Contact Sequence Chart on page 29 to verify contactor and relay positions. Refer to Section Three of the SEPTA Silverliner IV Troubleshooting Manual if repairs or adjustments are needed.

Trip and reset OLR1 Overload Relay for A1 Contactor to check that it causes A1 to drop out and pick up. Perform the same test for OLM1 and OLM2 M-contactor Over-loads in the Main Group. Check also that the proper fault lights light when relays are tripped and that they go off when the relays are reset. Whether using the Sequence Gun or operating from the control handles, make sure that the KM Controller moves to the proper position for propulsion or braking mode. Record the results of your inspection on [Form PI-1019](#). Make a report of any defects or repairs on a VMIS Work Order.





Southeastern Pennsylvania Transportation Authority
RECTIFIER/MAIN GROUP INSPECTION INSTRUCTIONS
Silverliner IV MU Locomotives (Inspection per 49CFR229.23)

ALL CARS

1. Inspect the Pantograph Pole by removing it from its protective container. Check for breaks, cracks, cleanliness and exposed fiberglass. If it is defective or missing, replace it. Check the container for holes, cracks or other defects that will prevent it from keeping the pole clean and dry. Record findings on [Form PI-1019](#).
2. Inspect all covers. Check for the condition and proper operation of all hooks, latches, hinges and weather seals. Make repairs and record defects as necessary.
3. Indicate on the 92-DAY INSPECTION RECORD that you have completed your part of the inspection.



Southeastern Pennsylvania Transportation Authority
RECTIFIER/MAIN GROUP INSPECTION INSTRUCTIONS
Silverliner IV MU Locomotives (Inspection per 49CFR229.23)

Contactor Sequence

SYMBOL	DEVICE	MASTER CONTROLLER POSITION					BRAKE VALVE
		SW	PI	P2	P3	OFF	BRK
B1, B2	Braking Contactors	-	-	-	-	X	X
BCR	Brake Control Relay	-	-	-	-	X	X
BX	Brake Relay	-	-	-	-	X	X
CCR	Circuit Check Relay	X	X	X	X	X	A
CLR	Current Level Relay	X	X	X	X	X	A
AHR	Anode Heater Relay	-	-	-	-	X	X
BCR	Braking Contactor	-	-	-	-	X	X
ER	Emergency Relay	X	X	X	X	X	X
A1	Staging Contactor	X	X	X	X	-	-
A2	Staging Contactor	-	-	X	X	-	-
A3	Staging Contactor	-	-	-	X	-	-
BR	Braking Relay	-	-	-	-	-	X
BRTD	Brake Release Time Delay	-	-	-	-	X	X
DBPR	Dynamic Brake Pressure Relay	-	-	-	-	-	X
DBR	Dynamic Brake Relay	-	-	-	-	-	X
P1, P2	Parallel Cam Contactors	-	-	-	-	X	A
PC	Power Check Relay	E	E	E	E	-	E
FWT	Forward Trainline Relay	C	C	C	C	-	-
RVT	Reverse Trainline Relay	D	D	D	D	-	-
SWTD	Switch Trainline Relay	x	X	X	X	-	-
PDR	Power Dump Relay	X	X	X	X	X	-
S2TD	P2 Trainline Relay	-	-	X	X	-	-
S3T	P3 Trainline Relay	-	-	-	X	-	-
PKR	Power Knockout Relay	X	X	X	X	X	-
BRT	Brake Release Trainline	X	X	X	K	X	-
FWR	Forward Relay	C	C	C	C	-	-
RVR	Reverse Relay	D	D	D	D	-	-
SW	Switch Relay	X	X	X	X	-	-
AMI, 2, 3, 4	Motoring Contactors	X	X	X	X	-	-
S3	P3 Relay	-	-	X	X	-	-
PMR	Pilot Motor Relay	-	-	X	X	B	A
PPR	Power Presence Relay	X	X	X	X	-	-
POR	Power Off Relay	G	G	G	G	F	F

LEGEND

-	Dropped Out	D	Picked up during reverse operation only.
X	Picked Up	E	Picked up with 90 amps of motor current only
A	Picked up as KM Controller runs from positions 17 to 1, dropped out during running back to position 17.	F	Picked up after brake cycle when controller runs from 1 to 17 and as controller holds in 17.
B	Picked up as the KM Controller runs into position 17, then drops out	G	Picked up during propulsion fault condition such as ER, GR, OLM 1, OLM2, TRF operations
C	Picked up during forward operation only.		



Southeastern Pennsylvania Transportation Authority
TRACTION MOTOR AND UNDERFLOOR INSPECTION
Silverliner IV MU Locomotives (Inspection per 49CFR229.23)

JOB E5 AND FORMS PI-1020 & PI-1021

TOOLS REQUIRED

MU Control Handles	MU Coach Key	Flashlight	Flat Blade Screwdriver
Phillips Screwdriver	Digital VOM	Amp Meter	Manometer
Test Light with Part #1828			
Light Bulb			

REFERENCE DOCUMENTS

- Silverliner IV Heavy Maintenance Manuals
- Silverliner IV Troubleshooting Manuals
- Silverliner IV Electrical Schematics
- SAB-1 Air brake and Train Handling Instructions
- SEPTA Railroad Consolidated Safety Manual
- ET-001 Electric Traction Instructions



****USE CAUTION****
HIGH VOLTAGE MAY BE PRESENT!

DISCUSSION

The technician(s) who performs this inspection must be a qualified member of the class or craft designated to perform this work and be thoroughly familiar with all aspects of MU locomotive operation under live operating conditions and must have completed training in railroad safety. All procedures must be performed under proper Blue Signal Protection and in accordance with all SEPTA, NORAC, and FRA safety regulations and procedures.

All items referred to in this document have electric wires, conduits, brackets, bolts, nuts, studs, clamps, etc., attached to the major components being inspected. Completion of this inspection includes but is not necessarily limited to all the items attached to the listed components. The underfloor visual inspection should concentrate on the electrical components listed. However, the technician who performs this inspection is responsible for reporting any observable defects in or around the areas of his primary responsibility.

PROCEDURES

1. Perform the Traction Motor Inspection as indicated on [Form PI-1020](#). Inspect and clean the brush holder insulators and check the brush holder assembly condition. Inspect the traction motor leads, cleats, commutator and flash ring for any defects. Measure and record commutator condition and brush length on [Form PI-1021](#). Replace any brushes that measure at or below the minimum length. Please note the following carbon brush types and sizes:

<u>Motor Type</u>	<u>Brush Grade</u>	<u>New Length</u>	<u>Minimum Length</u>
SL-IV 1259 Motors	E-60/T-583	3 inches	1-¾ inches

The following diagrams are from the GE Heavy Maintenance Manual GEK-38312 Section 2-5 covering the repair and maintenance of GE Model 1259 Traction Motors.

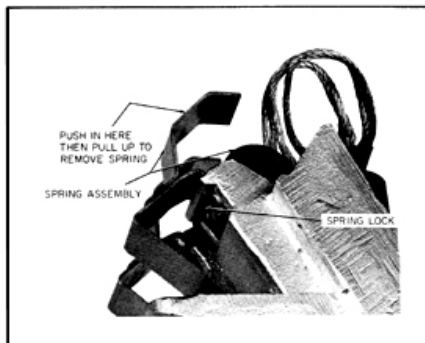

FIG. 5-2. DETAILS OF BRUSHHOLDER SPRING LOCK. E-16478

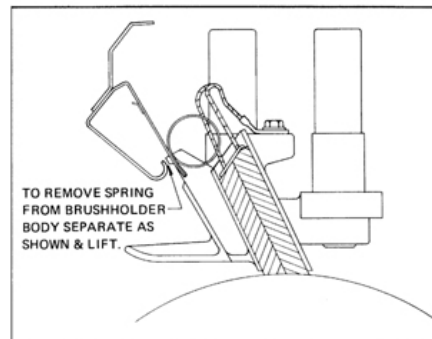

FIG. 5-4. SPRING REMOVAL & BRUSH POSITION IN HOLDER. E-18814



Southeastern Pennsylvania Transportation Authority
TRACTION MOTOR AND UNDERFLOOR INSPECTION
Silverliner IV MU Locomotives (Inspection per 49CFR229.23)

Brush/Brush Spring Inspection

- a. Push the spring in at the location shown in Fig. 5-2.
- b. Pull the spring out and pivot the spring down to the unlocked position shown in Fig. 5-3.
- c. To remove the spring, omit step b. Hold the brush spring straight up, separate the spring as shown in Fig. 5-4, and lift from the brush holder.

Brush/Brush Spring Inspection

- a. Release the brush springs as described above.
- b. Move the brushes up and down in the brush holder to be sure they move freely.
- c. Remove the brushes and inspect for wear. When measuring the length, measure the long side. Be sure the brush measures longer than the minimum length listed on previous page.
- d. Replace worn or damaged brushes. Be sure to use the same brush grade as the ones removed and do not mix brush grades. Mixing brush grades in the same motor or changing brushes to another grade may seriously affect commutation, surface film. Commutator and brush life.

Brush Replacement

- a. Release the brush spring.
 - b. Loosen the brush shunt terminal bolt.
 - c. Remove the brush and clean the carbonway of dust or debris.
 - d. Insert the new brush. Be sure the chamfer on the brush is correct. (See Fig. 5-4.).
 - e. Move the brush up and down in the carbonway to be sure it moves freely.
 - f. Install the new brush and pivot the brush to an upright position. Push the spring straight down and in so that the spring lock engages in the brush holder slot (Fig. 5-3).
 - g. Tug on the Brush holder shunt to ensure that the brush holder spring is properly engaged and that the brush moves against the tension of the brush holder. Failure to properly engage the brush holder spring will cause arcing and cause premature motor failure.
 - h. Install the shunt terminal under the terminal bolt and torque the bolt to 50–55 ft. lbs.
1. Inspect the axle ground brushes. Remove the ground brush, measure and record the length. The Axle Ground Brush is 1- $\frac{1}{4}$ in. X 1- $\frac{1}{4}$ in. X 2- $\frac{1}{4}$ in. GE Metite (R) Grade L. Minimum length is 1- $\frac{3}{8}$ in. Re-install the brush if it meets specifications or replace if the brush damaged or worn below the minimum length.
 2. Inspect all underfloor ground straps and repair or replace as needed.
 3. Inspect the Main Transformer ground and high-tension leads. Check oil level and cooling fans. Record all findings on [Form PI-1020](#) and report defects on a VMIS Work Order.
 4. On Silverliner IV cars, check the wheelslip speed sensors and the cables and connection attached to them.
 5. Inspect the ATC speed sensors and the cables and connections.
 6. Inspect the Main Smoothing Reactor, Cover, Cooling Ducts, and leads.
 7. Inspect the Auxiliary Smoothing Reactor, Cover, Cooling Ducts, and leads.
 8. Inspect all air ducts and hoses for proper connections, leakage, and physical damage.
 9. Inspect all Air Filters. Clean or replace as needed.



Southeastern Pennsylvania Transportation Authority
TRACTION MOTOR AND UNDERFLOOR INSPECTION
Silverliner IV MU Locomotives (Inspection per 49CFR229.23)

10. Inspect all underfloor resistors and insulators for damage and loose or disconnected wiring.
11. Check the resilient shock-absorbing mounts on all rotating underfloor devices.

Record all findings on [Form PI-1020](#) and [PI-1021](#). Use the space provided for additional remarks when defects or conditions require further explanation. Complete a VMIS Work Order to record defects whether repaired or held for repair at a later time. Report any serious defect or unusual condition to immediate supervisor as soon as practical.



Southeastern Pennsylvania Transportation Authority
AUXILIARY ROTATING EQUIPMENT INSPECTION
Silverliner IV MU Locomotives (Inspection per 49CFR229.23)

JOB E5 AND FORM PI-1022

TOOLS REQUIRED

Flashlight Profiler	Digital VOM Stoning Jig	Standard Electrician's Tool Set
------------------------	----------------------------	---------------------------------

REFERENCE DOCUMENTS

Silverliner IV Heavy Maintenance Manuals
Silverliner IV Troubleshooting Manuals
Silverliner IV Electrical Schematics
SAB-1 Air brake and Train Handling Instructions
SEPTA Railroad Consolidated Safety Manual
ET-001 Electric Traction Instructions

DISCUSSION

The technician(s) who performs this inspection must be a qualified member of the class or craft designated to perform this work and be thoroughly familiar with all aspects of MU locomotive operation under live operating conditions and must have completed training in railroad safety. All procedures must be performed under proper Blue Signal Protection and in accordance with all SEPTA, NORAC, and FRA safety regulations and procedures.

All items referred to in this document have electric wires, conduits, brackets, bolts, nuts, studs, clamps, etc., attached to the major components being inspected. Completion of this inspection includes but is not necessarily limited to all the items attached to the listed components.

The Auxiliary Equipment Inspection involves inspection of the Blower Motor Alternator (BMA) and/or the Single-Ended Blower (SEB).

BLOWER MOTOR ALTERNATOR

The GMG182 Blower Motor Alternator has the motor armature, alternator rotor, and exciting rotor mounted on a single shaft. Both the motor and the alternator are electrically independently of each other. A model 7A27B1 blower is mounted on the motor end of the shaft.

The motor receives its DC electrical power from the main transformer through a set of rectifiers (PRP4) and the Auxiliary Smoothing Reactor. The motor mechanically drives the alternator, the exciter and the blower.

The alternator produces 230 Volts, 60 Hertz, 3-phase electrical power used to run various auxiliary equipment. The exciter produces alternating current which is rectified internally and used to excite the fields of the alternator.

The blower is used to ventilate the motor alternator set and two of the four traction motors.

Refer to GE Heavy Maintenance Manual GEK-38312, Section 4-6 for a more detailed description of the Blower Motor Alternator set as well as a complete set of maintenance and repair instructions.

BLOWERS

Procedures for inspecting the GE Silverliner IV Blowers are identical to those described below for the Silverliner IV Blower Motor Alternator. Repeat the Periodic Inspection procedure for each machine on the vehicle being inspected. A complete discussion of the operating characteristics and specific procedures for maintenance and repair of the GE Model GDY-55 Single-Ended Blower can be found in Section 4-9 of the GE Heavy Maintenance Manual GEK-38312.

PERIODIC INSPECTION

Clean the exterior of the machine using dry, compressed air at 30 PSI max.

1. Check the covers for proper fit and that they have not been bent or warped. Replace if necessary.



Southeastern Pennsylvania Transportation Authority
AUXILIARY ROTATING EQUIPMENT INSPECTION
Silverliner IV MU Locomotives (Inspection per 49CFR229.23)

2. Remove the inspection covers from the motor end of the machine and blow out dirt, carbon dust, etc. from the interior of the machine using dry, compressed air at 30 PSI max.
3. Wipe dirt, grease, etc. off the brush holder insulators. Use a clean lintless cloth and if necessary, dip the cloth in a non-oily cleaning solution to remove foreign material.

CAUTION: An oil film left on the insulator will result in a rapid build-up of dust and dirt which will cause tracking, resulting in flashover and premature failure of the set.

4. Inspect the brush holder insulators for flashover damage, cracks, and burned or pitted surfaces. If any of these conditions exist, the brush holder is to be replaced. Refer to GE Heavy Maintenance Manual GEK-38312, Section 4-6 for replacement instructions.
5. Clean the creepage band with a clean, lintless cloth using a non-oily cleaning solution.
6. Check the creepage band for cracks, pitting, flashover damage, or lifting from the commutator. If any of these conditions exist, record this condition of [Form PI-1022](#) and report to immediate supervisor that the maintenance instructions recommend machine overhaul to correct this condition.
7. Inspect the brushes as follows:
 - a. Remove the brush spring and move the brush up and down in the carbon way to be sure it moves freely and does not bind.
 - b. Remove the brush from the carbon way and check for chipped, broken or worn brushes, and frayed shunts. Verify grade and brush type E-45. Minimum brush length is 1-3/4" inches measured on the long side.
 - c. Repeat steps a and b for all brushes. If any brush set does not meet minimum standards replace all brushes with Type E-45 brushes.
 - d. Check brush holder to commutator clearance. The correct clearance is 0.062-0.090 inch.



Southeastern Pennsylvania Transportation Authority
AUXILIARY ROTATING EQUIPMENT INSPECTION
Silverliner IV MU Locomotives (Inspection per 49CFR229.23)

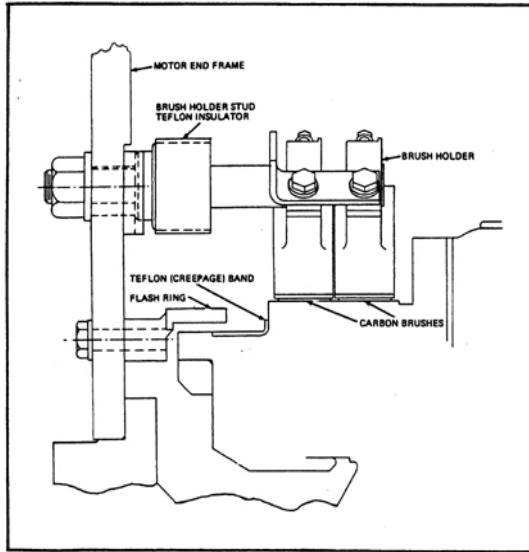

**FIG. 6-2. COMMUTATOR CHAMBER PARTS
LOCATION. E-18788**

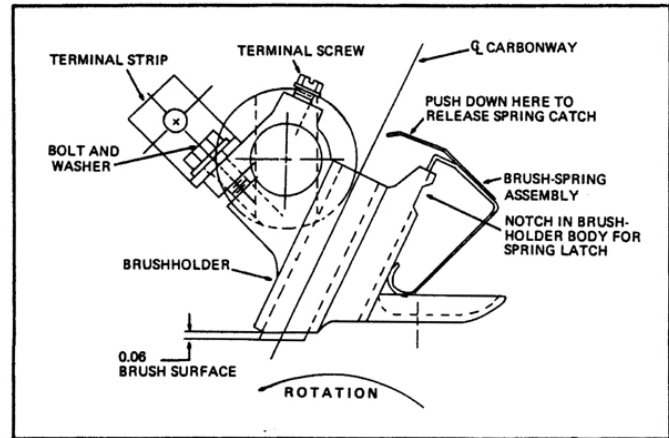

**FIG. 6-3. LOCATION OF BRUSHHOLDER
ASSEMBLY PARTS. E-17004**

BRUSH REPLACEMENT

Disconnect the brush shunt from the brush holder by loosening the terminal screw.



Release the brush spring and remove the brush from the carbon way.

- a. Insert a new brush in the carbon way. Position the brush, during installation, so that the bevel on the bottom of the brush is parallel with the bottom of the brush holder. Push the brush down until it seats on the commutator. Move the brush up and down in the carbon way to be sure that it is free. Insert the brush spring making sure that it locks in place.
- b. Reconnect the brush shunt terminal under the terminal screw on the brush holder. Arrange the brush shunts so they will clear the commutation riser; keep shunts away from other steel parts and be sure the shunts are not twisted.
- c. When replacing brushes, use grade type E-45. Be sure to use proper brush grade. Replace all brushes. Do not mix grades. Do not mix old and new brushes in the same machine. Failure to follow these guidelines will affect commutation, surface film, commutator and brush life. Premature machine failure could result from improper maintenance.
- d. The procedures shown above and below for inspecting commutator and brushes on the Silverliner IV Blower Motor Alternator are identical for the Single-Ended Blowers.

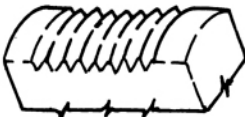

Southeastern Pennsylvania Transportation Authority
AUXILIARY ROTATING EQUIPMENT INSPECTION
Silverliner IV MU Locomotives (Inspection per 49CFR229.23)

COMMUTATOR PROFILING AND RESURFACING
Figure 6-4

ABNORMAL COMMUTATOR SURFACE CONDITIONS		
ABNORMAL SURFACE CONDITIONS	REMEDIAL RESURFACING METHODS (ON VEHICLE)	
	HAND STONE For Small Amounts of Copper Removal to Correct the Following	*FIXTURE GRIND To Remove Greater Amounts of Copper to Correct the Following
Threaded Brush Path 	✓	✓
**Grooved Brush Path 	✓	✓
Pitted	✓	
Burned Areas or Flat Spots	✓	✓
High Bars	✓	✓
Out of Round		✓
<p>*Do not resurface diameter of commutator below the minimum permissible diameter listed in data. Mica must not be flush with surface of commutator after grinding.</p> <hr/> <p>**A commutator with grooves worn by brushes does <u>not</u> require resurfacing unless:</p> <ol style="list-style-type: none"> 1. Brush breakage is occurring. 2. The mica is flush with the bottom of the brush groove. <div style="border: 1px solid black; padding: 10px; margin-top: 10px;"> <p>CAUTION: <i>If the brush groove diameter is less than the minimum permissible diameter (listed in Data) replace the commutator.</i></p> </div>		

Part of the Auxiliary Rotating Equipment Inspection involves profiling the DC Motor Commutator on the Blower Motor Alternator and the Single-Ended Blower. After completing the profiling procedure and/or resurfacing the commutator if needed, record the TIR (Total Indicated Runout), the MBTB (Maximum Bar-to-Bar) measurement, as well as the machine serial number, reconditioning vendor and date of completion in the spaces provided on [Form PI-1023](#).

Profiling Procedure

I. SETUP

1. Before inserting the sensor make sure that the commutator is clean so that a proper reading is produced. If the commutator has any foreign substances on its surface a high mica reading will occur.



Southeastern Pennsylvania Transportation Authority
AUXILIARY ROTATING EQUIPMENT INSPECTION
Silverliner IV MU Locomotives (Inspection per 49CFR229.23)

2. Also check to make sure that the sensor is clean because this will also produce a faulty reading. Watch for broken fragments that could be left behind after removing the brush because these fragments will affect the profile's reading.
3. Turn the profiling device on and insert the profiler sensor plug into the device.
4. After inserting the sensor, adjust the number on the profiler to zero mil by pushing the sensor against the commutator and turning the adjuster on the profiler. Make sure that the sensor is safely secure so that a proper reading is produced.
5. Mark a reference point on the commutator and turn it 360 degrees in the direction indicated by the brush and brush holder contours. This is done to check that the profiler is secure and at zero mil (this is just a test to avoid any unnecessary error). If there is any error, then you will have to adjust the sensor again.
6. After the profiler is adjusted to zero mil and the run is completed, you are ready to begin.
7. Press the mode/set button. A machine and track number will appear. The word record will also appear under the machine number.
8. Next push the start button, the word record will be blinking. Now you can begin to turn the commutator 360 degrees. Make sure that you only turn the commutator 360 degrees using the reference point that you already marked. After one complete revolution of the commutator push the stop button. The machine will automatically record the information.
9. Repeat this procedure for accuracy. The only difference for the second reading is that you have to push the arrow key when the track number is blinking to select another track.

II. PRINTING

1. When you are finished the testing and want to print out the results, press the mode/select button until the word print appears in the bottom right-hand corner.
2. In order to select the machine number, you want to print press the mode/set button. The machine number will be blinking. Use the arrow keys to select the machine you need to print.
3. In order to get the track number, do the same as the prior step except press the select/more button instead of the mode/set button.
4. Once you have the machine and track number, press the start button to begin printing.

RESURFACING THE COMMUTATOR

WARNING: The technician who performs this resurfacing procedure must wear adequate eye protection, and a respirator when needed to protect from dust and flying particles, and any additional Personal Protection Equipment (PPE) required per latest SEPTA policies.

1. See Figure 6-4 as an aid in determining the procedure required for resurfacing the commutator when necessary. Resurfacing is to be done when visible commutator conditions indicate a need for corrective action and when profile readings (TIR or MBTB) are outside of currently recommended specifications. Consult with immediate supervisor for current specifications and for a final determination to proceed with the resurfacing procedure.
2. Use a DC Welding Generator for power to run the motor. Open the breakers supplying power to the motor. Connect the positive lead to the movable side of the EFC (Equipment Fan Contactor) for the Single-Ended Blower or the movable side of the MAC-1 Contactor for the Blower Motor Alternator. Connect the negative lead to the 50CD common wire which can usually be found on Potential Relays PTR-4 or PTR-5 or Alternator Field Relay AFR located in the Auxiliary Group. Figure 6-5 shows an alternate connection diagram for



Southeastern Pennsylvania Transportation Authority
AUXILIARY ROTATING EQUIPMENT INSPECTION
Silverliner IV MU Locomotives (Inspection per 49CFR229.23)

connecting the welding generator to the machine that needs resurfacing. Use this method when a component is not mounted on the vehicle.

WARNING: For the safety of the personnel under the car during the grinding operations, a man must be stationed at the welding generator supplying the electric power so that the power can be immediately removed if an emergency should arise.

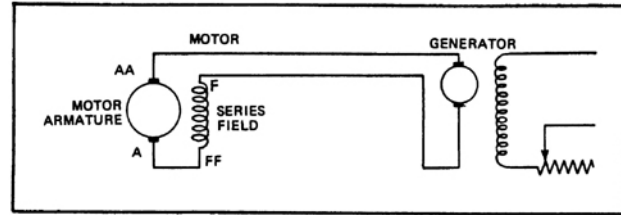

FIG. 6-5. DIAGRAM OF CONNECTIONS TO RUN MOTOR-ALTERNATOR FROM WELDING SET. E-671

3. POLISHING. If the commutator is smudged and only needs POLISHING, use canvas, crocus cloth, fine (4/0) sandpaper, or Tri-M-ITE™ paper which is manufactured by Minnesota Mining and Mfg. Co. (3M). NEVER use emery cloth on a commutator. The abrasive particles will scratch the surface. The emery particles are also conductive and will cause a flashover when lodged between the commutator segments.
4. HAND STONING. For mildly grooved or etched commutators HAND STONING is permissible when used to clean the brush surface. The hand stone must be finishing grade and should have a curved surface to fit the commutator and be large enough to span several commutator segments with the curved surface along the long dimension. To stone, connect the machine as described above and start the motor. Place the curved surface of the finishing grade stone lightly against the rotating commutator. Rest the square end of the stone against the brush holder assembly. Slowly move the stone back and forth across the commutator surface maintaining a light but definite pressure at all times. Periodically remove the stone and feel the commutator surface with a fiber stick to determine where the rough areas remain. DO NOT TOUCH THE COMMUTATOR WITH YOUR UNPROTECTED HAND. HIGH VOLTAGE IS PRESENT. Continue stoning until all rough spots are ground away and the surface feels smooth. After the stoning operation, the motor should be blown out with dry compressed air (30 PSI max.) to remove the accumulation of copper dust from the commutator bars and slots and from the general area inside the machine and around the armature. *PLEASE NOTE: Failure to properly remove the copper dust will result in flashover.*

WARNING: Polishing and hand stoning are used rarely. Almost all stoning is to be done using a commutator grinding kit jig mounted in one of the machine brush holders. Stoning requirements will be determined by your immediate supervisor and based on the profiling results. The current SEPTA Personal Protection Equipment (PPE) policies must be followed.

5. GRINDING: When greater amounts of copper are to be removed to correct a deeply grooved commutator, threaded or out-of-round commutator or to restore a commutator to specifications as indicated by the profiling measurements, a commutator grinding kit containing a brush holder mounted stoning jig must be used.

Before installing the grinder, inspect it for cleanliness. A dirty grinder may tighten and bind during the grinding operation. If the grinder is very dirty, it may be necessary to disassemble the grinder to remove the accumulated dirt and copper. After the grinder is reassembled, lubricate the grinder ways with the graphite lubricant furnished in the grinder kit. Proper distribution of the lubricant will minimize the tendency to collect dirt and copper chips. Install the grinder and resurface the commutator as follows:

- a. Disconnect and remove the lower left-hand brush holder assembly.
- b. Bolt the adapter in the brush holder position using the same bolt and washer removed from the brush holder stud. The adapter should be adjusted radially as far off the commutator as possible.
- c. Leave one positive and one negative brush in the motor and remove remaining brushes.
- d. Retract the radial carriage slide of the grinder fully and mount the grinder on the adapter without the stones.



Southeastern Pennsylvania Transportation Authority
AUXILIARY ROTATING EQUIPMENT INSPECTION
Silverliner IV MU Locomotives (Inspection per 49CFR229.23)

- e. Check for finger clearance between the grinder and the commutator surface (0.62 inch). If there is less clearance than this, check for interference which prevents the adapter from being positioned to obtain this clearance.
- f. Bolt the grinder to the adapter and tighten the bolts finger tight.
- g. Place a fiber strip (approximately 0.030 thick) on the commutator surface under the grinder.
- h. Advance the radial carriage slide so it is resting lightly on the fiber strip. Traverse the carriage back and forth checking for variation in the clearance. Readjust the position of the grinder on the adapter by rotation to obtain uniform clearance at both limits of travel.
- i. Tighten the mounting bolts securely.
- j. Retract the radial carriage slide and assemble the grinder stones first cutting the wood on the top of the inner stone to the shape as shown in figure 6-6. This will allow the stone to sweep to the inner edge of the brush surface. If new stones are used, contour the ends on a Carborundum wheel to approximately fit the curvature of the commutator at the desired angle.

NOTE: Finish and medium grade stones are furnished with the commutator resurfacing kit. For most applications the finish grade is recommended, but on heavily grooved and worn commutators with deep flat spots, the medium grade stones can be used for roughing and the finish grade used for final grinding.

- k. Using the radial feed, advance the stones lightly against the fiber strip and using the longitudinal feed, traverse the carriage back and forth across the commutator as a final check for variation in the clearance.
- l. Remove the fiber strip.
- m. Lift the alternator brushes and start the motor.
- n. Begin grinding by radially feeding the stones lightly against the commutator and then moving them back and forth across the surface longitudinally from the riser end to a point 0.50 inch beyond the outer extremity of the brush surface. More pressure can be applied as the stones are seated and this can be maintained at about 1/20th of a revolution of a radial feed for every four to six sweeps of traverse motion. Cutting action should take place at the trailing edge of the stones. Do not take too deep a cut. This will result in dragging an excessive amount of copper over the edges of the commutator bars. If possible, use some means of collecting the copper and abrasive dust thrown off by the grinding operation. For example, use a vacuum-cleaning device with the cleaning orifice set just behind the trailing edge of the stones.
- o. Begin lightening the pressure of the stones near the end of the grinding operation. A very light finish cut will drag the least amount of copper thus reducing the amount of time required to clean the commutator slots after grinding.
- p. Stop the motor and if medium grade stones were used, change to finish grade stones and repeat Steps j, k, l, m, n, and o.
- q. After the grinding, the motor should be blown out with dry compressed air to remove accumulated copper dust from the commutator bars and slots.

6. UNDERCUTTING

After a commutator has been resurfaced, the mica between the bars should be undercut to a depth of .046 inch. Undercutting should be done with a sharp-edged tool with a cutting width of 0.033 inch. A sharp hacksaw blade may be used but caution must be observed in that a dull blade or saw produces small cracks in the mica into which dirt or moisture may accumulate and cause a breakdown in the insulation between segments.

With practice, handheld power undercutters can be used. Follow the tool manufacturer's instructions and use slot guides and depth gages for accurate, uniform cuts. Make a few practice passes over a scrap commutator to get the "feel" of the tool. Care must be taken not to let the power undercutter jump out of the slot and across the commutator surface. The high-speed operation of the blade will quickly gouge the commutator.



Southeastern Pennsylvania Transportation Authority
AUXILIARY ROTATING EQUIPMENT INSPECTION
Silverliner IV MU Locomotives (Inspection per 49CFR229.23)

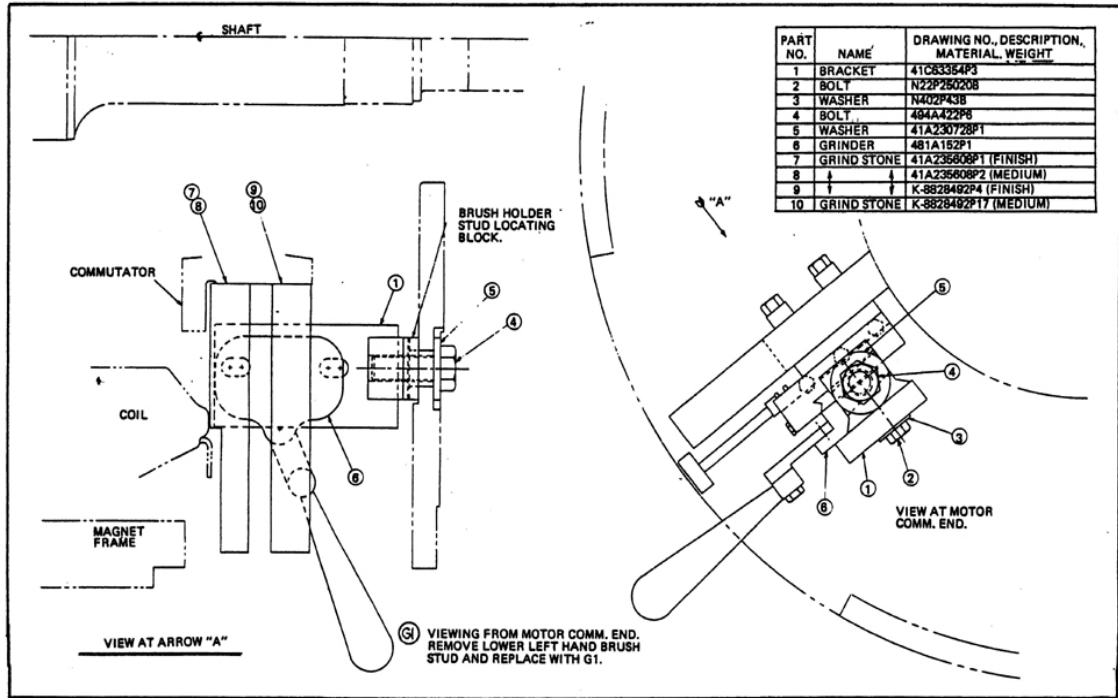

FIG. 6-6. COMMUTATOR GRINDER ASSEMBLY. E-18474



Southeastern Pennsylvania Transportation Authority
AUXILIARY ROTATING EQUIPMENT INSPECTION
Silverliner IV MU Locomotives (Inspection per 49CFR229.23)

7. RAKING

Resurfacing usually leaves particles and slivers of copper hanging on the bar edges or ledged in the undercut slots. These must be removed before the motor is placed in service, or the particles may bridge the side mica and cause a flashover.

- a. With the motor shut off, brush out dirt and copper whiskers attached to the trailing edge of the bars with a stiff-bristle brush, preferably one with nylon bristles. A new paint brush or stencil brush with the bristles cut short for added stiffness may also be satisfactory. If stoning and undercutting has produced considerable dragging of copper from the edges of the bars, use a raking tool to remove the copper fins and ragged edges. Such a tool can easily be made by grinding a 60-degree "V" on a screwdriver. Rake the trailing edge of the bar. If the tool is ground with flat sides and used with moderate pressure as a raking tool, it will remove ragged copper fins and break the sharp edges of the bars. See Figure 6-7 for an illustration of the tool. Another method of removing copper fins is to rake the slots with a piece of fiberboard approximately 0.045 inches thick.
- b. Thoroughly blow out the motor with clean, dry, compressed air to remove copper and dust. Pay particular attention to the commutator and brush rigging.
- c. Start the motor.
- d. If slots have been raked with fiberboard or a raking tool, sand the commutator with sandpaper to remove small pieces of copper sticking up from the edges of the bars.
- e. Stop the motor and install a full set of brushes. Do not use brushes which are worn or chipped. If new brushes are installed, start the motor and seat them with a white brush-seater stone.
- f. Check motor commutation with full line voltage applied. If excessive sparking is present, remove line voltage and thoroughly blow out the motor again with clean, dry compressed air.



Southeastern Pennsylvania Transportation Authority
ROOF AND PANTOGRAPH INSPECTION
Silverliner IV MU Locomotives (Inspection per 49CFR229.23)

JOB E6 AND FORM PI-1024

TOOLS REQUIRED

Flashlight Digital VOM Standard Electrician's Tool Set Spring Scale

REFERENCE DOCUMENTS

Silverliner IV Heavy Maintenance Manuals
Silverliner IV Troubleshooting Manuals
Silverliner IV Electrical Schematics
SAB-1 Air brake and Train Handling Instructions
SEPTA Railroad Consolidated Safety Manual
ET-001 Electric Traction Instructions



****USE CAUTION****
HIGH VOLTAGE MAY BE PRESENT!

DISCUSSION

The technician(s) who performs this inspection must be a qualified member of the class or craft designated to perform this work and be thoroughly familiar with all aspects of MU locomotive operation under live operating conditions and must have completed training in railroad safety. All procedures must be performed under proper Blue Signal Protection and in accordance with all SEPTA, NORAC, and FRA safety regulations and procedures. Additionally, any technician who works on the roof of an MU located inside the shop must be certified as having received and passed the instructions in the use and application of the FALL PROTECTION SYSTEM.

All items referred to in this document have electric wires, conduits, brackets, bolts, nuts, studs, clamps, etc., attached to the major components being inspected. Completion of this inspection includes but is not necessarily limited to all the items attached to the listed components. Report all findings on [Form PI-1024](#) and report defects in VMIS.

Pantograph

The AC propulsion circuit is supplied with 11,000 volts, 25/60 Hz power, or 25,000 volts, 60 Hz power from an overhead catenary system. A Schunk style pantograph, located on the "A" end of each single and each B car of a married pair collects the power. The pantograph installation includes a lightning arrester, LA, a pneumatically operated grounding switch, GS, and a current transformer, CT1. The lightning arrester breaks down electrically under High surge voltages, preventing damage to the main transformer in the event of a catenary lightning strike. The pneumatic grounding switch is operated automatically by protective devices and short circuits the pantograph (and catenary wire) to the roof of the car in the event an overload condition exists. This action will cause a loss of power to the train by tripping the track circuit breaker and preventing damage to the main transformer of the car.

WARNING.

Do not enter the pantograph area or otherwise climb on the roof of the car with the pantograph extended to the catenary wire. High voltage is present in the catenary wire and touching the pantograph could prove fatal. Observe all pertinent railroad safety rules.

The current transformer supplies a representative sample of total current being drawn from the catenary wire into the car to operate the following devices and circuits:

1. Pantograph Lowering Relay, PLR. This relay will trip when a sudden, severe overload occurs within the traction circuit. When tripped, the ground switch is operated until the track breaker trips. The pantograph on the faulty car or pair is then lowered to the roof.



Southeastern Pennsylvania Transportation Authority
ROOF AND PANTOGRAPH INSPECTION
Silverliner IV MU Locomotives (Inspection per 49CFR229.23)

2. Thermal Relay, THR. This relay will trip when a continuous overload is present that is not severe enough to trip PLR. When a car draws 300 amperes for from 7 to 15 seconds, THR will trip, operating the grounding switch. The pantograph is lowered to the roof.
3. Transformer, TXPL. The secondary of this transformer supplies a scale voltage representing car intake current to the Performance and Fault Indication Panel (P&FI). A meter on this panel indicates the amount of power drawn by that car. In addition, a scaled voltage signal is sent to the pedestal level card FD483. This signal is used to limit the maximum current draw from the catenary to 150 amps.

DESCRIPTION

The Schunk pantograph is a retractable current-collecting device which collects and conducts current from an overhead wire for car operation. When the pantograph is not in use, it is retracted and latched. When the latch is released, spring-loading causes the pantograph to rise and move the current-collecting shoe assembly into contact with the overhead wire. When air pressure is admitted to a large air cylinder, a mechanical force greater than the spring loading causes the pantograph to retract and latch. The pantograph latch can be released by actuating an unlatching air cylinder or by operating a manual release rod.

The principal parts of the pantograph include the base frame, lower frame, upper frame, raising mechanism, pan head with current collecting shoes and pneumatic system.

The wear strips are made of carbon, approximately 1/2 in. thick. They are not to be lubricated. The strip can be worn down to a point near the metal frame before the strip requires change out. However, it is important that there not be any breaks, cracks or gouges in the carbon wear strips that could catch the catenary or cause damage to the wire or the pantograph.

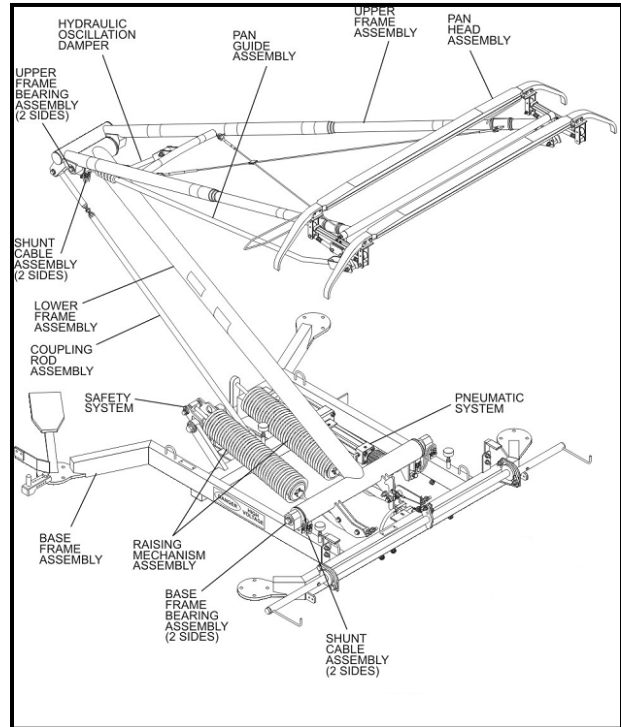

OPERATION

The pantograph can be raised or lowered by switches in the cab or by magnet valves located under the car as shown in Fig 14-11.

The speed at which the pantograph will raise and lower can be regulated by adjusting valves on the pneumatic system located on the pantograph assembly (see Air Cylinder Assembly figure to the right). Item 5 is the raising flow control assembly and item 2 is the lowering control assembly.

The raising speed can be adjusted by turning the valve (6) clockwise to decrease speed or counterclockwise to increase speed.

The lowering speed can be adjusted by turning the valve (3) clockwise to decrease speed or counterclockwise to increase speed.

AIR CYLINDER ASSEMBLY

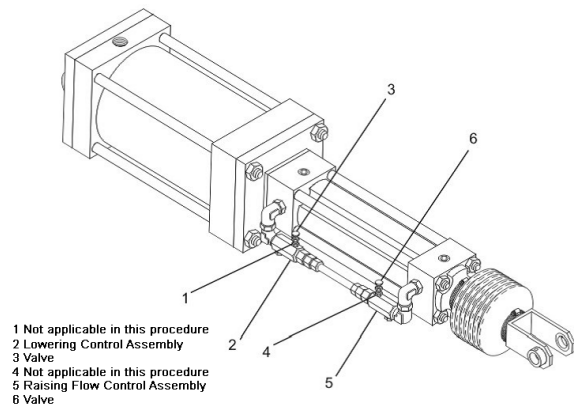



Southeastern Pennsylvania Transportation Authority
ROOF AND PANTOGRAPH INSPECTION
Silverliner IV MU Locomotives (Inspection per 49CFR229.23)

Controls NOT currently used to adjust the system:

Needle Valve.

The needle valve was used to regulate the lowering speed of the pantograph. It is located under the car between the magnet valves and the quick release valve, directly behind the magnet valve assembly. This valve was turned clockwise to slow the DOWN motion and counterclockwise to speed the DOWN motion.

Flow-Restricting Valve

The flow-restricting valve was used to regulate the raising speed of the pantograph. It is located in the same vicinity under the car as the needle valve, but directly under the quick-release valve. This valve was turned clockwise to speed the UP motion and counterclockwise to slow the UP motion.

NOTE: Check the Needle and Flow-Restricting Valves to verify that there is not an issue with the correct speed settings of the controls on the pantograph.

Quick-Release Valve (non-adjustable)

The quick-release valve allows air pressure to enter the lowering air cylinder to lower the pantograph. When the pantograph rises, the quick-release valve diverts the exhaust air from the cylinder chamber to the flow-restricting valve. It is located in the same vicinity as the needle and flow-restricting valves.

Vent Valve (non-adjustable)

The vent valve is used to permit air flow into and out of the lowering air cylinder as the pantograph raises and lowers. This valve is located on the lowering air cylinder.

Air Pressure Data

The lowering and unlatching cylinders are designed for the following pressures:

Maximum pressure	150 lb.
Basic pressure.....	90 lb.
Minimum pressure to lower pantograph	50 lb.
Minimum pressure to unlatch pantograph	36 lb.



Southeastern Pennsylvania Transportation Authority
ROOF AND PANTOGRAPH INSPECTION
Silverliner IV MU Locomotives (Inspection per 49CFR229.23)

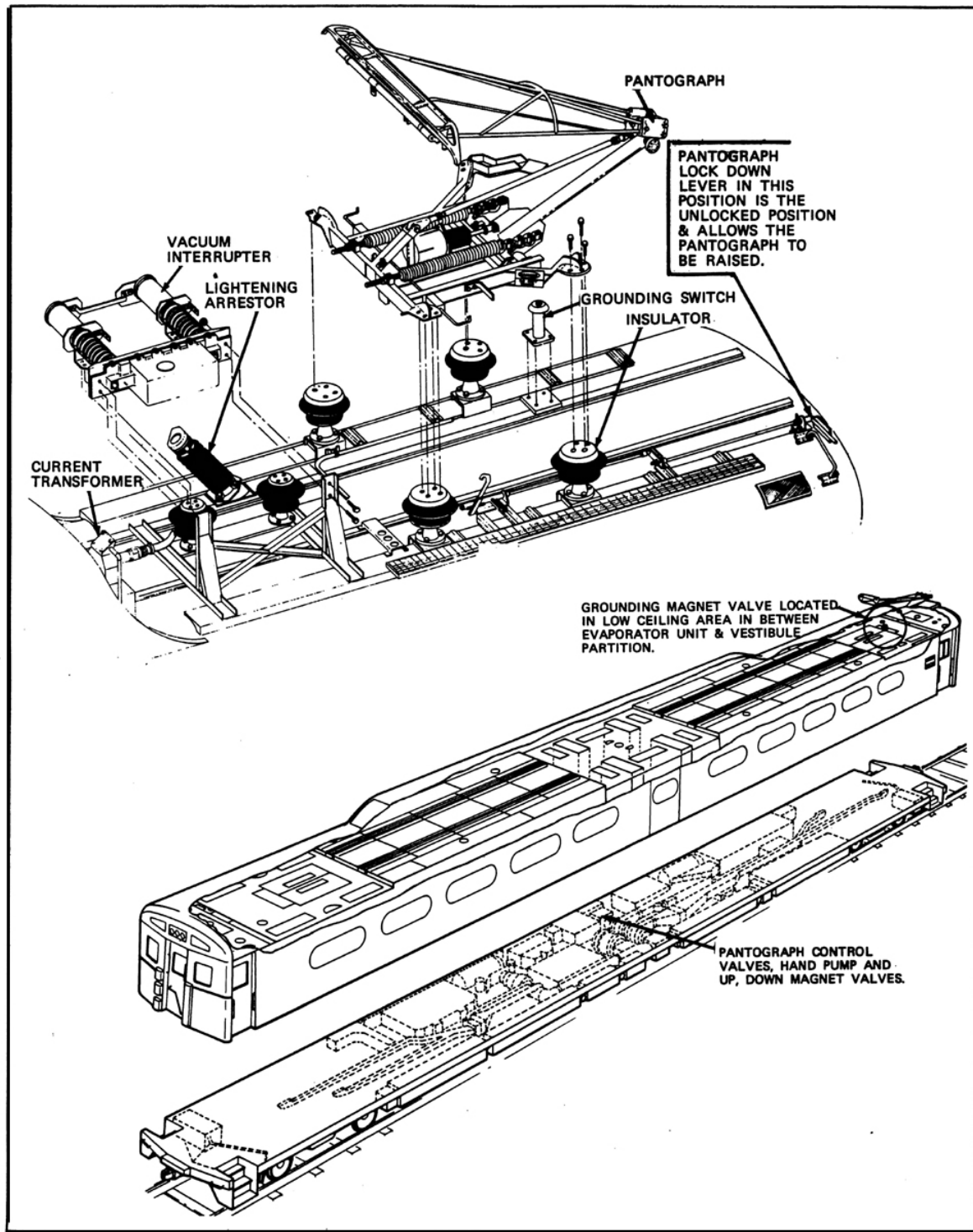

FIG. 14-11. PANTOGRAPH EQUIPMENT LOCATION. E-19846



Southeastern Pennsylvania Transportation Authority
ROOF AND PANTOGRAPH INSPECTION
Silverliner IV MU Locomotives (Inspection per 49CFR229.23)

ROOF INSPECTION — ALL CARS

CAUTION

USE EXTREME CAUTION WHEN WALKING ON THE ROOF. EVERY EMPLOYEE WHO GOES ONTO THE ROOF OF A VEHICLE INSIDE THE SHOP MUST BE PROPERLY CONNECTED TO THE FALL PROTECTION DEVICE. OBSERVE AND USE HAND HOLDS. OBSERVE ALL SAFETY RULES THAT PERTAIN TO WALKING AND WORKING IN A HAZARDOUS ENVIRONMENT

High Tension Transformer Cable

Visually inspect the High-Tension Transformer Cable for physical damage and proper insulation. Look for cracks or breaks in the insulation, places where rubbing or chafing might occur, and clean, secure connections.

Insulators

Visually inspect all insulators. Check for cracks, loose bolts and other visible defects. Tap each insulator lightly with a small metal tool or bar. Good insulators will ring with a tone. Cracked insulators will make a dull thud sound. Clean all insulators with an approved cleanser. Cracked or otherwise damaged insulators must be replaced before the vehicle is allowed to return to service. Insulators must be clean and dry before the vehicle goes out to be energized under live catenary wire.

Current Transformer (CT)

Visually inspect the Current Transformer (CT). Make sure that there is no physical damage and that all electrical connections are tight and properly insulated. Make sure that the CT is securely mounted to the supporting bracket and that the High-Tension Conduit is secure. Look for burn marks and other indications of flashing or arcing.

Roof Fuse

Visually inspect the Roof Fuse on cars so equipped. Look for clean, secure connections and secure mounting.

Lightning Arrestor

Inspect and clean the Lightning Arrestor.

Danger Signs

Inspect and clean all danger signs. Replace those that have become illegible.

Dynamic Brake Resistors

Visually inspect the Dynamic Brake Resistors by walking along the roof. Use a flashlight or drop light and carefully inspect the resistors for physical damage, secure connections, flashing, burning, or melted metal. Report and/or repair any defects.

Roof

Inspect the entire roof area for any signs of physical damage or arcing. Remove all debris, including loose and miscellaneous hardware.

Antennas

Clean and inspect antennas for signs of physical damage.



Southeastern Pennsylvania Transportation Authority
ROOF AND PANTOGRAPH INSPECTION
Silverliner IV MU Locomotives (Inspection per 49CFR229.23)

Footholds and Handholds

Inspect all footholds and handholds for damage and tightness.

Manual Ground Switch and Lockdown Mechanism

Test the ground switch lever and lock-down assembly and inspect the device for proper operation and physical damage. Ensure that the grounded cable is good condition and securely connected. When engaged the ground switch hook should securely engage the pantograph tubing and the grounding knife switch must be fully engaged.

Intercar Jumper

Visually inspect intercar jumper cables for physical damage. Inspect for cracks or breaks in insulation. Clean connection and check for tightness.

Air Lines

Clean and inspect the air lines for leakage or physical damage. Replace air lines annually.

Pantograph UP/DOWN Controls

Place the pantograph control switch in the down position to allow air to the down cylinder.

Note: If air is not present in the down cylinder, the pantograph will rise too quickly, and damage may result.

Test the pantograph up switch for proper operation. Test the trainline and local pantograph down switch for proper operation. Pantograph Down controls should function in any cab regardless of cab control. Ensure the pantograph comes completely down and latches.

Manually test the UP and DOWN Magnet Valves. Inspect for damage or leakage.

Pantograph Lowering Relay (PLR)

Trip the Pantograph Lowering relay and check that the pantograph comes down then latches and the Ground Switch plunger activates. Inspect the Ground Switch for proper operation and physical damage. Replace any damaged copper shunts. Ensure that the plunger is able to make solid contact with the grounding plate.

Pantograph Hand Pump

Inspect pantograph hand pump for signs of physical damage. Clean and lubricate as required. Test Pantograph hand pump for proper operation.

PANTOGRAPH INSPECTION

Initial Conditions: Pantograph is lowered.

Safety/Shear Pin Holder

Remove yellow safety pin (2) from the storage holder (3) and install in the safety linkage near the shear pin (4). Inspect holder for physical damage, functionality and that 5 shear pins are installed.



Southeastern Pennsylvania Transportation Authority
ROOF AND PANTOGRAPH INSPECTION
Silverliner IV MU Locomotives (Inspection per 49CFR229.23)

STORAGE

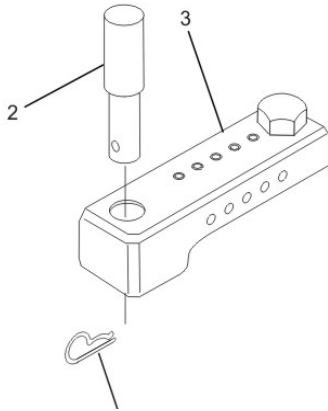

INSTALLATION

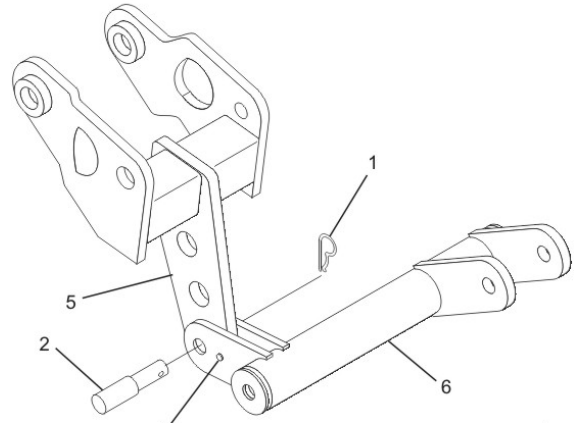

General Pantograph Inspection

Clean and inspect all shunts for signs of physical damage, arcing and poor connection. Inspect pneumatic connections for physical damage and leaks. Inspect coupling rod bearing for wear.

Pantograph Lubrication

Lubricate all pivot points and moving parts.

Diagonal Cables

Inspect diagonal cables for mechanical defects and proper tightness.

Pantograph Shoe (Carbon Wear Strips)

Inspect pantograph shoes for abnormal chips or cracks. Minor chips and cracks are normal. Smooth grooves with a file. Replace shoe if chips, grooves and cracks are deemed inoperable.

Measure the thickness of the pantograph shoes (carbon wear strips). The minimum allowable thickness of a carbon strip is 1/4" measured anywhere on either contact strip.

Note: If either contact strip is damaged or worn, both contact strips must be renewed. Renewing only one contact strip creates an uneven carbon height condition resulting in poor contact with the catenary wire, rapid carbon wear, and arcing.

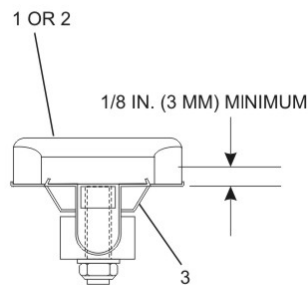



Southeastern Pennsylvania Transportation Authority
ROOF AND PANTOGRAPH INSPECTION
Silverliner IV MU Locomotives (Inspection per 49CFR229.23)

Inspect end horns for signs of physical wear damage. Replace as required.

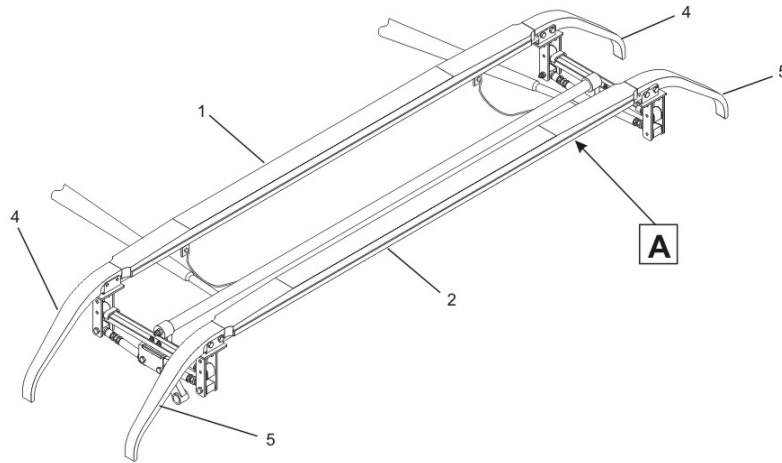

Check for parallelism by placing a straight edge across both carbon strips and ensure they are parallel.

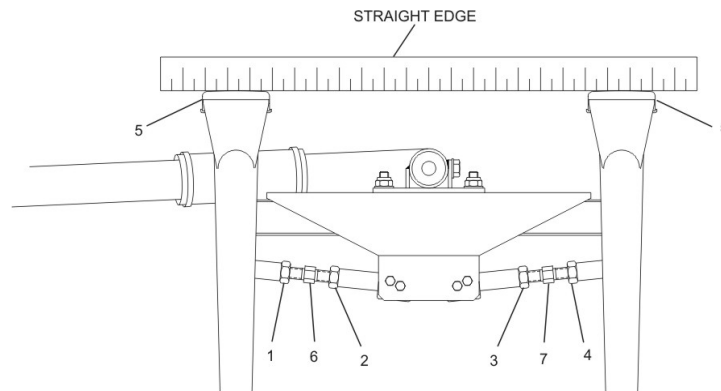

Pantograph Camera

Clean Pantograph Camera lens to maintain clear view. Camera should be adjusted annually according to ECN 4563.





Southeastern Pennsylvania Transportation Authority
ROOF AND PANTOGRAPH INSPECTION
Silverliner IV MU Locomotives (Inspection per 49CFR229.23)

Pantograph Level

Check the pantograph level by placing a straight edge from the Pan Head Assembly to the knuckle and verifying with a level.

WARNING: Knuckle sitting high may result in arcing in low catenary areas.





Southeastern Pennsylvania Transportation Authority
ROOF AND PANTOGRAPH INSPECTION
Silverliner IV MU Locomotives (Inspection per 49CFR229.23)

Pantograph Contact Force

Remove the hydraulic oscillation damper. Measure the contact force of the pantograph from the latched position up to a height of 7 ½ feet using a spring scale. Nominal force throughout the range should be 21 ± 2 lbs.

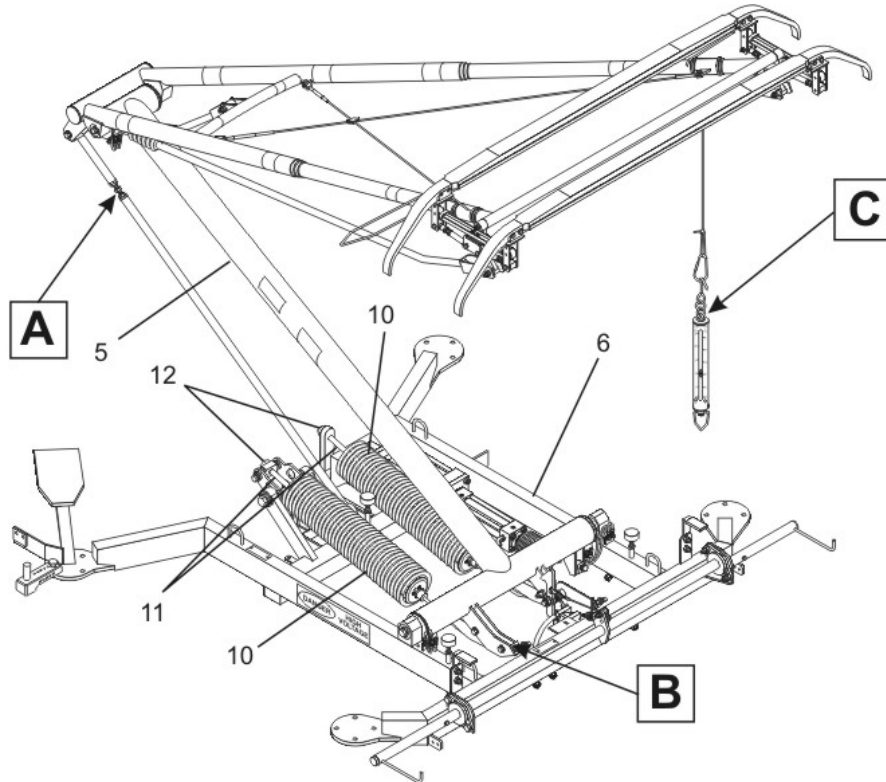

Pantograph Raising and Lowering Speed

Check the Pantograph Raising Speed by measuring the time it takes to get from the latched position to a height of 8 feet. Check the Pantograph Lowering Speed by measuring the time it takes to lower the pantograph from a height of 8 feet. Raising time should be 7 seconds and lowering time should be 5 seconds.

Factors that could cause the raising and lowering speed to vary and need adjustment are contact force adjustment, oil viscosity, higher summer temperatures, lower winter temperatures, air pressure, and cylinder wear.



Southeastern Pennsylvania Transportation Authority
HVAC INSPECTION
Silverliner IV MU Locomotives (Inspection per 49CFR229.23)

JOB E7 AND FORM PI-1035

Tools Required.

Multimeter	Digital Thermometer	
Manifold gauge set.	Conductor key	Jumper

Reference Documents

GE SLIV Troubleshooting Manual Ch.8

Procedure

Circuit Tests

For each heater circuit with its respective contactor closed, measure resistance in circuit. If the resistance is substantially different than the correct value, determine which heater element is open, damaged, or shorted. Repair or replace as needed.

Protective Heat Check

Place a jumper from TB-873 on the PC Board (80+003), to the J2 receptacle pin "S". Physically inspect auto drain dryer and air compressor sump tank heaters for proper operation. Make all necessary repairs to the heat circuits.

Inspect and clean condenser coils and Main Transformer after cooler with a rag to remove dirt and debris.

Electrical Inspection

Visual inspections for ports, contactors, and other electrical components.

TCU Temperature Readings

Read and record the temperatures on the TCU for ambient air, return air, and outlet duct.

HVAC Compressor Checks

Install manifold gauge set at ports in refrigeration control box to check high side pressure. To check low side pressure, place jumper across low pressure switch and open Heating and Air Conditioning Circuit Breaker for 15 seconds. Check low side pressure.

Record pressures at which the low-pressure switch and modulation pressure switch open and close.

Check oil and Freon levels and indicate state.

Follow directions given on [Form PI-1035](#). For further information reference GE SLIV Troubleshooting Manual Chapter 8 – HVAC on VTIL.



Southeastern Pennsylvania Transportation Authority
WHEELS, MECHANICAL EQUIPMENT AND SAFETY APPLIANCE
PERIODIC INSPECTION
Silverliner IV MU Locomotives (Inspection per 49CFR229.23)

JOB M1 AND FORMS PI-1025, PI-1026 AND PI-1027

TOOLS REQUIRED

Flashlight
Coupler Gage

Calibrated Wheel Gages
Car Height Gage

Tape Measure

REFERENCE DOCUMENTS

Silverliner IV Heavy Maintenance Manuals
SAB-1 Air brake and Train Handling Instructions
Title 49 Chapter II of the Code of Federal Regulations Parts 229 and 238
SEPTA Maintenance Instructions SMI 0-1001
APTA Safety Standards
Field Manual of the AAR Interchange Rules, Rule 41, Section A
AAR Manual of Standards and Recommended Practices, Sections G and G-II
SEPTA Railroad Consolidated Safety Manual

DISCUSSION

The technician(s) who performs this inspection must be a qualified member of the class or craft designated to perform this work and be thoroughly familiar with all aspects of MU locomotive operation under live operating conditions and must have completed training in railroad safety. All procedures must be performed under proper Blue Signal Protection and in accordance with all SEPTA, NORAC, and FRA safety regulations and procedures.

This procedure covers inspections performed on items that fall into categories of Running Gear, Mechanical Equipment and Safety Appliances which are Items 2, 4 and 7 on Form FRA 6180-49 A. The employee who performs this inspection will certify its completion by signing in the designated place on Form FRA 6180-49 A. This inspection procedure will be performed only by those employees holding current certification as Qualified Maintenance Persons or Car Inspectors (aka QMP). The QMP who performs this inspection must be thoroughly familiar with the standards outlined in the documents referenced above as they relate to the inspection of SEPTA MU Locomotives in rail passenger service.

The Reference Documents listed above must be available and the inspector must consult with his or her immediate supervisor as the final arbiter for conditions that are considered to be near or outside of the compliance limits.

PROCEDURE

Perform the inspection as outlined on [Form PI-1025](#). Refer to 49CFR Part 229 and/or Part 238 for compliance standards. Access standards via VTIL Library Annex links and/or bookmarks or via the Internet at <http://www.ecfr.gov/>.



Southeastern Pennsylvania Transportation Authority
WHEELS, MECHANICAL EQUIPMENT AND SAFETY APPLIANCE
PERIODIC INSPECTION
Silverliner IV MU Locomotives (Inspection per 49CFR229.23)

CARBODY MEASUREMENTS

SILVERLINER IV — GE CARS

CAR BODY HEIGHT:	Measure from rail to bottom of end sheet:
DOUBLE UNIT:	B or Handbrake end 40- $\frac{1}{2}$ " \pm $\frac{1}{4}$ " A or Pantograph end 47- $\frac{3}{4}$ " \pm $\frac{1}{4}$ "
SINGLE UNIT:	Both Ends 40- $\frac{1}{2}$ " \pm $\frac{1}{4}$ "
FLOOR or BUFFER HEIGHT:	All GE cars — buffers should be equal to car body floors.
FLOOR TO RAIL HEIGHT:	50"min.–52"max.
PLOW AND PILOT HEIGHTS	3" min.–6"max.
BOLSTER TO RAIL HEIGHT	24- $\frac{1}{2}$ " – 25- $\frac{1}{2}$ "
COUPLER HEIGHT:	34" to 35" measure from rail to center line of coupler pin.
TRUCK FRAME:	Measure from top of truck corner to rail: 33- $\frac{1}{4}$ ". Level the truck by laying a straight-edge along the top of the truck frame; measure 33- $\frac{1}{4}$ " from rail at each corner. Shim at helical springs if needed. Measurements may also be taken from the bottom of the pedestal legs to the top of the rail head: this measurement will be 7- $\frac{3}{8}$ " with car weight. Note: Truck will measure 34- $\frac{1}{4}$ " at the corners and 8- $\frac{3}{8}$ " from the pedestal legs to the rail head without car weight.
SIDE BEARING – CLEARANCE:	Measure between truck wear plate and bottom bearing surface of bolster. Clearance must be 1/16" min. and 3/16" max. Shim for proper clearance as center bearing plate wears down.
J-HOOK CLEARANCE:	Maintain 1- $\frac{7}{8}$ " clearance between J-Hook and flange on bolster with bellows inflated.
CENTER BEARING — FRICTION WEAR PLATE:	New = 1" thick at $\frac{3}{4}$ "-Replace center plate.
AIR SPRINGS:	Inflated operating height from inside of top ring to the inside of bottom ring should be a minimum of nine (9") inches and a maximum of nine and three quarters inches (9- $\frac{3}{4}$ ").
LATERAL RUBBER – BUMPERS:	Maximum $\frac{1}{4}$ " gap on both sides.
TOP OF BUFFER TO CENTER LINE OF COUPLER PIN:	16" min.–17"max.

ALL MEASUREMENTS ARE WITH AIR SPRINGS INFLATED EXCEPT WHERE NOTED.



Southeastern Pennsylvania Transportation Authority
AIR BRAKE INSPECTION
Silverliner IV MU Locomotives (Inspection per 49CFR229.23)

JOB M2 AND FORMS PI-1028 AND PI-1029

TOOLS REQUIRED

MU Control Handles	Calibrated Air Gages	Standard Mechanical Tool Set
Salem Air Gage Tester		

REFERENCE DOCUMENTS

Silverliner IV Heavy Maintenance Manuals
Silverliner IV Troubleshooting Manuals
SAB-1 Air brake and Train Handling Instructions
SEPTA Air Brake Training Manual
Title 49 Chapter II of the Code of Federal Regulations Parts 229 and 238
APTA Safety Standards

SEPTA Railroad Consolidated Safety Manual

DISCUSSION

The technician(s) who performs this inspection must be a qualified member of the class or craft designated to perform this work and be thoroughly familiar with all aspects of MU locomotive operation under live operating conditions and must have completed training in railroad safety. All procedures must be performed under proper Blue Signal Protection and in accordance with all SEPTA, NORAC, and FRA safety regulations and procedures.

The Air Brake Inspection is to be performed during each periodic inspection in compliance with 49CFR Part 229 and 49CFR Part 238 and which corresponds to Item 1 on FRA Form 6180-49 A. The employee who performs this inspection will certify its completion by signing in the designated place on Form FRA 6180-49 A. This inspection procedure will be performed only by those employees holding current certification as Qualified Maintenance Persons or Car Inspectors (aka QMP). The QMP who performs this inspection must be thoroughly familiar with the standards outlined in the documents referenced above as they relate to the inspection of SEPTA MU Locomotives in rail passenger service.

The Reference Documents listed above must be available and the inspector must consult with his or her immediate supervisor as the final arbiter for conditions that are considered to be near or outside of the compliance limits.

PROCEDURE

BRAKE CALIBRATION PROCEDURE

1. Set up cab.
2. Charge brakes.
3. Use in-date calibration gauge (0-200 PSI in one PSI Increments) with a test plug made to fit into the test cocks. Make sure the O-ring is in good condition on the test plug. Renew if questionable.
4. Apply the test gauge into the following cocks one at a time to calibrate the following:
 - 1) Red arrow, brake cylinder pressure range 0-85 PSI (normal operation).
 - 2) White arrow, brake pipe pressure range 0-115 PSI. Items 1 and 2 are on one dual-function gauge.
 - 3) Red arrow, main reservoir range 0-150 PSI.
 - 4) White arrow, equalizing reservoir range 0-115 PSI. Items 3 and 4 are on one dual-function gauge.

Test each function of the dual gauge in three positions across its range, i.e., test brake cylinder gauge at 10, 45 & 75 PSI; test brake pipe gauge at 20, 60 & 100 PSI, etc. All gauges must be accurate to within three PSI Of the test gauge and must also be well lighted and readable through the glass lenses. Adjust or renew gauges that do not comply. Repair/replace any leaking cocks.



Southeastern Pennsylvania Transportation Authority
AIR BRAKE INSPECTION
Silverliner IV MU Locomotives (Inspection per 49CFR229.23)

5. Adjust brake pipe and equalizing reservoir to 110 PSI using the 110# regulator. The N1-A regulating/reducing valve is located under the first passenger seat inside the car. The regulating valve adjustment screw is located on the bottom of the valve and requires a 9/32" spline wrench.
6. Make a full-service brake application. Full-service brake range is 62-67 PSI. Adjust to this range using the service limiting valve adjusting nut located on top of the 26-C control or service Portion. Turn the nut counterclockwise to increase pressure. Make sure the nut is safety wired after completing adjustments.

Air Suspension System

Visually inspect the air springs, hoses, piping, and leveling valves. Record the height of the air springs.

Air Valves and Coupler Connections

Operate all uncoupling valves, noting proper response. Check Main Reservoir and Brake Pipe connections. Use poppet valve gage to check the N2A Automatic Coupler Air Connections.

Shop Brake Test

Tests must be performed from each operating cab. Note that all brake units can be released, and that when released, the adjustment does not allow a space exceeding one-half inch between the shoe and the wheel.

1. Fully charge the brake system (5 minutes) in electric holding. Brakes must remain applied, noting that all brake shoes are firmly against the wheels.
2. Note that air gauges read 110 psi equalizing reservoir and 110 psi brake pipe.
3. Release the dead-man pedal and move the master controller out of safety position and turn the EP switch to off. Note that brake cylinder pressure is reduced to zero.
4. Depress the dead-man pedal and release the master controller.
5. With the brake valve handle, reduce equalizing pressure 15 psi. Note that brake pipe pressure is similarly reduced.
6. Close the brake pipe cut-off valve: Note that brakes are applied and that there is no emergency application of the brakes. Wait 30 seconds and check brake pipe leakage which must not exceed 3 psi per minute in shop test. No equalizing reservoir leakage is permitted.
7. Cut-in the EP switch and move the brake valve handle in the service position, noting that brake pipe is reduced at the application magnet valve as indicated by cab brake pipe gauge.
8. Place the brake valve handle in emergency position and note that an emergency application of the brake does occur.
9. Immediately cut-in the brake pipe cut-out cock and place the brake valve handle in electric Holding position, observing that when the reset button is depressed, the brake pipe recharging is prevented for approximately 45 seconds.
10. When the system is fully charged, move the brake-valve handle to release position and note that brake cylinder pressure is reduced to 10 psi in less than 8 seconds.
11. Cut-out -the EP switch and move the brake valve handle to reduce equalizing reservoir pressure in 10 psi increments. Note that brake cylinder pressure is built up in approximately two- and one-half times the total reduction of brake pipe. Note that the dead-man pedal and the master controller can be released with 60 psi brake cylinder pressure.
12. With dead-man pedal depressed, recharge the system, and when fully charged, reduce equalizing reservoir pressure 30 psi. While making this reduction, note that equalizing pressure drops 110 psi Co 90 psi in less than 5 seconds and, that brake cylinder pressure is limited to 65 psi. Release the dead-man pedal then move the brake valve handle towards release, noting that there is an emergency application of the brakes when brake cylinder pressure is reduced below 45 psi.



Southeastern Pennsylvania Transportation Authority
AIR BRAKE INSPECTION
Silverliner IV MU Locomotives (Inspection per 49CFR229.23)

13. Depress the deadman pedal and recharge the system, placing the brake valve handle in “release” position for approximately two minutes, after which, move the brake valve handle to service position reducing equalizing reservoir 25 psi. When all exhaust of Check brake valve has stopped, recharge the brake pipe 10 psi. Brakes must remain applied.
14. Cut-in the EP switch and reapply the brakes sufficiently to nullify the dead-man, and then unseat the conductor’s valve to cause an emergency application of the brakes.

Snow Brake

1. Place snow brake switch to on and recharge the system. Make a full-service application and then release the brakes. Note that brake cylinder pressure is between 8 psi and 10 psi. Adjust reducing valve if necessary, using test air gauge.
2. Turn snow brake switch to the off position then apply brakes in service, release and observe that brake cylinder is reduced to zero.
3. Place jumper wire from pin ^T/ to pin 43 at the electric head on the "F" end of the car. Note that brake cylinder pressure is again maintained between 8 and 10 psi. Remove Jumper and note that brakes release*. Repeat procedure by placing jumper wire from pin-28 to pin 64. This entire procedure must be repeated for the trailing electric head.

Single Car Brake

1. When car is equipped with a single car emergency brake and with the system fully charged, engage the emergency button on the trailing cab, noting that there is no emergency application, the brake cylinder pressure goes immediately to 60/70 psi and then continues to and is maintained at 100 psi.
2. Reset the button and from the operating cab depress the emergency button, noting that cab make-up is lost, and that brake cylinder pressure does rise to and is maintained at approximately 100 psi — Also note that this does cause brake pipe to be vented.

Pressure Switch Settings - SEASONALS ONLY

	<u>Pick-up (psi)</u>	<u>Drop-Out (Psi)</u>
1. Dynamic Brake Pressure Switch	107	103
2. Emergency Pressure Switch	78	65
3. Dead-Man Pressure Switch	60	45
4. Brake Cylinder Pressure Switch	25	15
5. Uncoupling Pressure Switch	90	60
6. Low Brake Pressure Switch	20	15
7. High Brake Pressure Switch	45	30
8. Brake Pipe Pressure Switch	75	60
9. Air Compressor Governor	130	140

Air Pressure Settings - TEST AND CALIBRATE

1. Main Reservoir 130-140 PSI
2. Main Reservoir Safety 150 PSI
3. Brake Pipe 110 PSI



Southeastern Pennsylvania Transportation Authority
AIR BRAKE INSPECTION
Silverliner IV MU Locomotives (Inspection per 49CFR229.23)

- | | |
|--------------------------------|---|
| 4. Equalizing Reservoir | 110 PSI |
| 5. Control Air | 90 PSI |
| 6. Full-Service Brake Cylinder | 65 PSI |
| 7. Emergency Brake Cylinder | 77 PSI minimum with 63 PSI in Air Springs |
| 8. Snow Brake | 8-10 PSI |
| 9. Single Car Emergency | 100 PSI |
| 10. Dead-in-tow Brake Pipe | 110 PSI |



Southeastern Pennsylvania Transportation Authority
INTERIOR MECHANICAL INSPECTION
Silverliner IV MU Locomotives (Inspection per 49CFR229.23)

JOB M3 AND FORMS PI-1030, PI-1031, AND PI-1032

TOOLS REQUIRED

Standard Mechanical Tool Set

REFERENCE DOCUMENTS

Silverliner IV Heavy Maintenance Manuals
Title 49 Chapter II of the Code of Federal Regulations Parts 229 and 238
APTA Safety Standards
SEPTA Railroad Consolidated Safety Manual

DISCUSSION

The technician(s) who performs this inspection must be a qualified member of the class or craft designated to perform this work and be thoroughly familiar with all aspects of MU locomotive operation under live operating conditions and must have completed training in railroad safety. All procedures must be performed under proper Blue Signal Protection and in accordance with all SEPTA, NORAC, and FRA safety regulations and procedures.

The Interior Mechanical Inspection procedure covers the inspection and minor repairs of items found inside passenger compartment, the vestibules and the operator's compartment. Report findings on [Form PI-1030](#). List defects and repairs on [Form PI-1031](#). Follow the instructions on [Form PI-1032](#) making sure that all the signs listed are placed in the vehicle in the designated storage compartment.

During the course of this inspection, the inspector must look for any conditions that would present a hazard to a passenger or crew member. Items that are otherwise in compliance, but have conditions present that could catch or damage clothing, present a tripping hazard or otherwise injure a passenger or crew member must be repaired or reported. Replace any missing hardware and tighten loose screws and other items that can be seen to need minor attention. Draw upon your experience and observations and use your professional discretion in reporting to your immediate supervisor any conditions that represent a possible failure trend or that are hazardous or safety-related but not listed under the items to be inspected.

Graffiti, excessive dirt and debris must be cleaned or reported and cleaned before the vehicle re-enters revenue passenger service.

This inspection procedure will be performed only by those employees holding current certification as Qualified Maintenance Persons or Car Inspectors (a.k.a. QMP). The QMP who performs this inspection must be thoroughly familiar with the standards outlined in the documents referenced above as they relate to the inspection of SEPTA MU Locomotives in rail passenger service.

The Reference Documents listed above must be available and the inspector must consult with his or her immediate supervisor as the final arbiter for conditions that are considered to be near or outside of the compliance limits.

PROCEDURE:

Operator's Compartment:

1. In the operator's compartment, check all the weatherstripping. Report or replaced any that is ripped, torn or missing. Weatherstripping must be in good enough condition to prevent air leakage and maintain compartment temperature with a properly functioning heater.
2. Inspect the sun visors for proper operation and/or damage. Repair or replace as needed.
3. Inspect the cab windows and window seals. Ensure that all glazing complies with current regulations. Glazing that is cracked or broken must be replaced. Replace any damaged or leaking windows seals. Report or replace any glazing that is clouded.
4. Inspect and test the operation of the engineer's seat. Be especially aware of safety concerns. Repair or replace as needed.
5. Inspect the flooring deck plate. Report and buckling or other deformity.



Southeastern Pennsylvania Transportation Authority
INTERIOR MECHANICAL INSPECTION
Silverliner IV MU Locomotives (Inspection per 49CFR229.23)

6. Inspect the buffer plates and buffer pins. Report or repair any tripping hazards.
7. Inspect safety chains. Replace any that are damaged or missing. Replace any bent or missing s-hooks.
8. Inspect the rubber diaphragms that protect the walkway between Silverliner IV married pairs for rips, tears or other damage. Report or replace as needed.
9. Inspect the headlight lens and rubber gaskets. Repair or replace as needed.
10. Inspect the destination sign boxes for damage and proper operation. Repair or replace as needed.
11. Clean the passenger compartment ventilation grills to ensure adequate air flow. Inspect for damage. Repair as needed.
12. Check the condition and operation of each trap door including latches, bumpers, stops, spacers, switches and sills. Make any needed repairs or report defective conditions for repair prior to the vehicle returning to service.
13. Check the fire extinguisher. Make sure that it has been certified as filled within the last year and that it has not been discharged since the last inspection. Make sure that the protective devices that prevent accidental discharge are in place.
14. Inspect the operator compartment side doors, storm doors, door latches, bumpers, stops and weatherstripping. Make sure each door and door lock operate properly. Repair or replace parts as necessary.

Passenger Compartment:

1. Inspect the main doors and door locks for damage, excessive wear and proper operation. Repair as needed.
2. Inspect the door checks. Make sure that the door remains open when latched. Repair or replace parts as needed.
3. Inspect and test the door closers. Door closers cushion the opening and closing motion of the doors and should be adjusted to permit easy opening and not permit the door to slam or close too quickly. See GE Heavy Maintenance Manual GEK-38312 Section 11-3 for a complete discussion of the operating characteristics and instructions for repair and maintenance. Adjust, repair or replace the door closer as needed.
4. Inspect and test the Body End Door Solenoids. The passenger compartment door should stay open when latched and close when the proper signal is given by the operator. Adjust, repair or replace as needed.
5. Replace all passenger compartment air ventilation filters located in the ceiling at each end of the vehicle. Use only approved replacements. Report any questionable or non-complying conditions observed during the replacement procedure.
6. Lubricate and test all control panel access doors. Adjust, repair, or replaced parts as needed.
7. Lubricate and test all pencil locks and key locks. Adjust, repair or replace as needed.
8. Inspect all seats and armrests. Repair or replace any ripped, torn or damaged seats.
9. Inspect the seats frames for damage or looseness. Seats must mount securely to the flooring. Repair or replace as needed.
10. Check that emergency tools are stored properly, and protective covers are in place.
11. Check the flooring for rips, tears, buckling or other hazardous conditions. Report, repair or replaced as needed.
12. Check all decals inside and outside. Ensure that the decals currently required are in place and in good and readable condition. Replace as needed.
13. Check all passenger compartment glazing including emergency windows, emergency window handles, spill shields and windows sealing rubbers. Make sure all are in good condition. No cracked or broken glazing is permitted. No loose, ripped or missing window sealing rubbers are permitted. Replace any damaged spill shields or inoperable emergency window handles.



Southeastern Pennsylvania Transportation Authority
INTERIOR MECHANICAL INSPECTION
Silverliner IV MU Locomotives (Inspection per 49CFR229.23)

14. Inspect wall panels for damage. Report, repair, or replace as needed.
15. Check all overhead doors, vents and access panels for damage tightness and excessive vibration. Repair as needed.
16. Check baggage racks for damage or looseness. Repair as needed.
17. Check all coat hooks. Repair or replace any that are damaged or missing. Tighten any that are loose.
18. Check for any loose or missing screws or other fastening devices. Tighten or replace as needed.
19. Clean, remove, report, or repair any graffiti or vandalism-related damage.
20. Inspect advertisement signs. Make sure they are held securely in the proper locations. Remove any that are vandalized.
21. Inspect all interior signs, decals, warnings, instructions, and logos. Repair or replace as needed.
22. Inspect the anemostat vents in the operator's compartment. Lubricate the operating mechanism and test. Adjust, repair, or replaced as needed.
23. Inspect all number signs. Repair or replace as needed.

Report all findings on [Form PI-1030](#). List all minor defects and repairs on [Form PI-1031](#). Fill out a VMIS Work Order for any defects or non-complying conditions that need attention that cannot be given during the time allowed for the inspection procedure. Follow the instructions for signage on [Form PI-1032](#).



Southeastern Pennsylvania Transportation Authority
LUBRICATION AND OIL SAMPLING PERIODIC INSPECTION
Silverliner IV MU Locomotives (Inspection per 49CFR229.23)

JOB M4 AND FORMS PI-1033

TOOLS REQUIRED

Flashlight	Oil Drums/pump	Spill Containment Material	Standard Mechanics' Tool set
------------	----------------	----------------------------	------------------------------

REFERENCE DOCUMENTS

Silverliner IV Heavy Maintenance Manuals
SEPTA Railroad Consolidated Safety Manual

DISCUSSION

The technician(s) who performs this inspection must be a qualified member of the class or craft designated to perform this work and be thoroughly familiar with all aspects of MU locomotive operation under live operating conditions and must have completed training in railroad safety. All procedures must be performed under proper Blue Signal Protection and in accordance with all SEPTA, NORAC, and FRA safety regulations and procedures.

The employee who performs this inspection will certify its completion by signing in the designated place on Form FRA 6180-49 A. This inspection and repair procedure will be performed only by those employees holding current certification as Qualified Maintenance Persons or Car Inspectors (aka QMP). The QMP who performs this inspection must be thoroughly familiar with the standards outlined in the documents referenced above as they relate to the inspection of SEPTA MU Locomotives in rail passenger service.

The Reference Documents listed above must be available and the inspector must consult with his or her immediate supervisor as the final arbiter for conditions that are considered to be near or outside of the compliance limits.

The primary responsibility of the employee(s) who performs this job is to check the oil levels in all gear units and the air compressor. This job includes assessing the condition of the oil based on general observation and experience; filling the gear unit and air compressor oil reservoirs to capacity; and taking samples of the gear oil and preparing the samples for shipping to the testing lab. This job also includes replacing the gear oil as scheduled every two years; replacing the air compressor oil as scheduled every year and replacing the air compressor desiccant drier beads as scheduled every year.

PROCEDURE:

For each gear unit:

1. Remove the sealing wire or bolt retention device from the fill plug or cap and remove the plug or cap.
2. Check the oil level and make sure that it is visible at the fill plug or cap.
3. Use a 2-ounce plastic sample bottle to collect a sample to be sent to the lab.
4. Fill the gear unit to capacity if needed.
5. Replace the plug or cap and re-install the sealing wire or bolt retention device.
6. Inspect the gear unit for damage or leaks and record findings on [Form PI-1033](#). Immediately inform immediate supervisor of unusual conditions, damage or other defects.
7. Record the gear unit serial number in the space provided on [Form PI-1033](#).
8. If the oil change is scheduled, drain the oil into suitable containers. Refill with approved 80/90W Gear oil. Dispose of the used oil in an environmentally safe way. Follow steps 4, 5, 6, and 7 above for each gear unit inspected or serviced.
9. Oil sample bottles should be delivered the storeroom where they will be packed and shipped to the testing facility.



Southeastern Pennsylvania Transportation Authority
LUBRICATION AND OIL SAMPLING PERIODIC INSPECTION
Silverliner IV MU Locomotives (Inspection per 49CFR229.23)

Air Compressor [The Air Compressor is not installed on all SL-IV Cars].

1. Check the Air Compressor oil level and oil condition. Refill as needed.
2. Check the air compressor air filter and change if dirty.
3. Inspect the Air compressor for leaks, damage or other unusual conditions. Record findings on [Form PI-1033](#) and report any unusual conditions to immediate supervisor.
4. When the oil is changed, renew the oil filter, air intake filter, cooling duct air filter, and O-rings.
5. When the desiccant dryer beads (charge) are to be renewed, refer to procedure in Salem Air Dryer Manual for complete instructions.
6. Record all work performed and inspection results on [Form PI-1033](#). Report any defects found and/or repaired on a VMIS Work Order.



Southeastern Pennsylvania Transportation Authority
EXTERIOR MECHANICAL INSPECTION AND REPAIR
Silverliner IV MU Locomotives (Inspection per 49CFR229.23)

JOB M5 AND FORMS PI-1027

TOOLS REQUIRED

Flashlight
Coupler Gage

Calibrated Wheel Gages
Car Height Gage

Tape Measure
Brake Adjustment Tool

REFERENCE DOCUMENTS

Silverliner IV Heavy Maintenance Manuals
SAB-1 Air brake and Train Handling Instructions
Title 49 Chapter II of the Code of Federal Regulations Parts 229 and 238
SEPTA Maintenance Instructions SMI 0-1001
APTA Safety Standards
Field Manual of the AAR Interchange Rules, Rule 41, Section A
AAR Manual of Standards and Recommended Practices, Sections G and G-II
SEPTA Railroad Consolidated Safety Manual

DISCUSSION

The technician(s) who performs this inspection must be a qualified member of the class or craft designated to perform this work and be thoroughly familiar with all aspects of MU locomotive operation under live operating conditions and must have completed training in railroad safety. All procedures must be performed under proper Blue Signal Protection and in accordance with all SEPTA, NORAC, and FRA safety regulations and procedures.

The employee who performs this inspection will certify its completion by signing in the designated place on Form FRA 6180-49 A. This inspection and repair procedure will be performed only by those employees holding current certification as Qualified Maintenance Persons or Car Inspectors (aka QMP). The QMP who performs this inspection must be thoroughly familiar with the standards outlined in the documents referenced above as they relate to the inspection of SEPTA MU Locomotives in rail passenger service.

The Reference Documents listed above must be available and the inspector must consult with his or her immediate supervisor as the final arbiter for conditions that are considered to be near or outside of the compliance limits.

The primary responsibility of the employee(s) who perform this job is to make minor repairs that are found and reported by the employee performing the inspection Job #M1. This job also covers the inspecting and lubrication of the handbrake and the replacement of worn brake shoes.

The employee(s) who perform this job is responsible for reporting and/or repairing defects discovered during the performance of the duties listed or while making repairs found by other inspectors.

PROCEDURE:

1. Lubricate and Test Handbrake.

The handbrake is the gear/chain type. It is used to apply and hold two tread brake shoes against two wheels on the B-truck to hold the vehicle in place when the vehicle is parked. The handbrake must hold sufficiently to ensure that the vehicle does not move when air brake pressure is unavailable. It is applied by rotating the handwheel clockwise until resistance prevents any further tightening and released by turning the handwheel counterclockwise.

Lubricate moving parts. Test the handbrake by first applying, then checking that the package brakes connected to the handbrake are firmly applied. When testing the handbrake outside the shop, first apply, then release the air brakes and ascertain that the vehicle does not move.

Inspect the handbrake chain and chain supports, guides, and connecting links or pins. Replace any that are cracked, worn, broken, damaged or missing.

2. Replace all brake shoes worn beyond the shop condemning limits. Refer to diagrams and instructions on the following pages for further instructions.



Southeastern Pennsylvania Transportation Authority
EXTERIOR MECHANICAL INSPECTION AND REPAIR
Silverliner IV MU Locomotives (Inspection per 49CFR229.23)

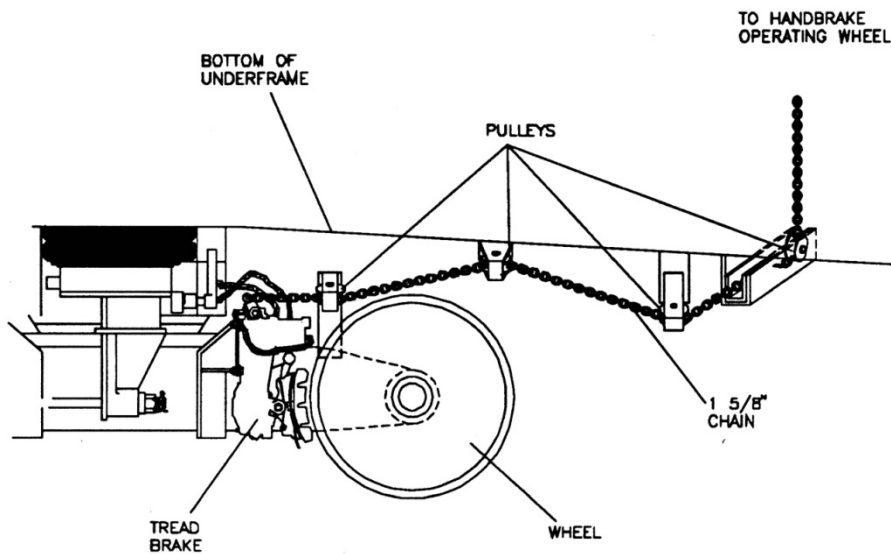
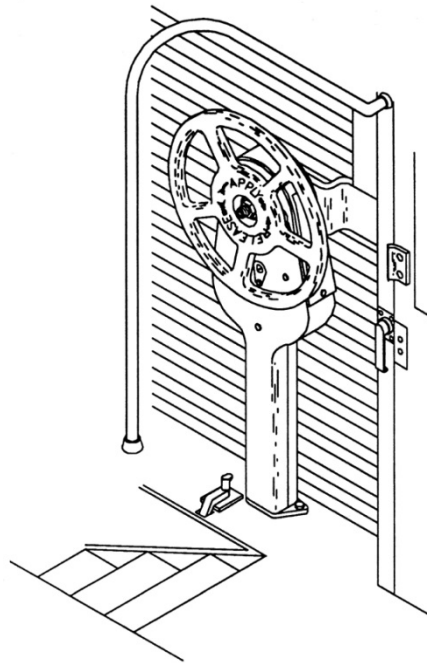

Handbrake Installation, Undercar



Southeastern Pennsylvania Transportation Authority
EXTERIOR MECHANICAL INSPECTION AND REPAIR
Silverliner IV MU Locomotives (Inspection per 49CFR229.23)

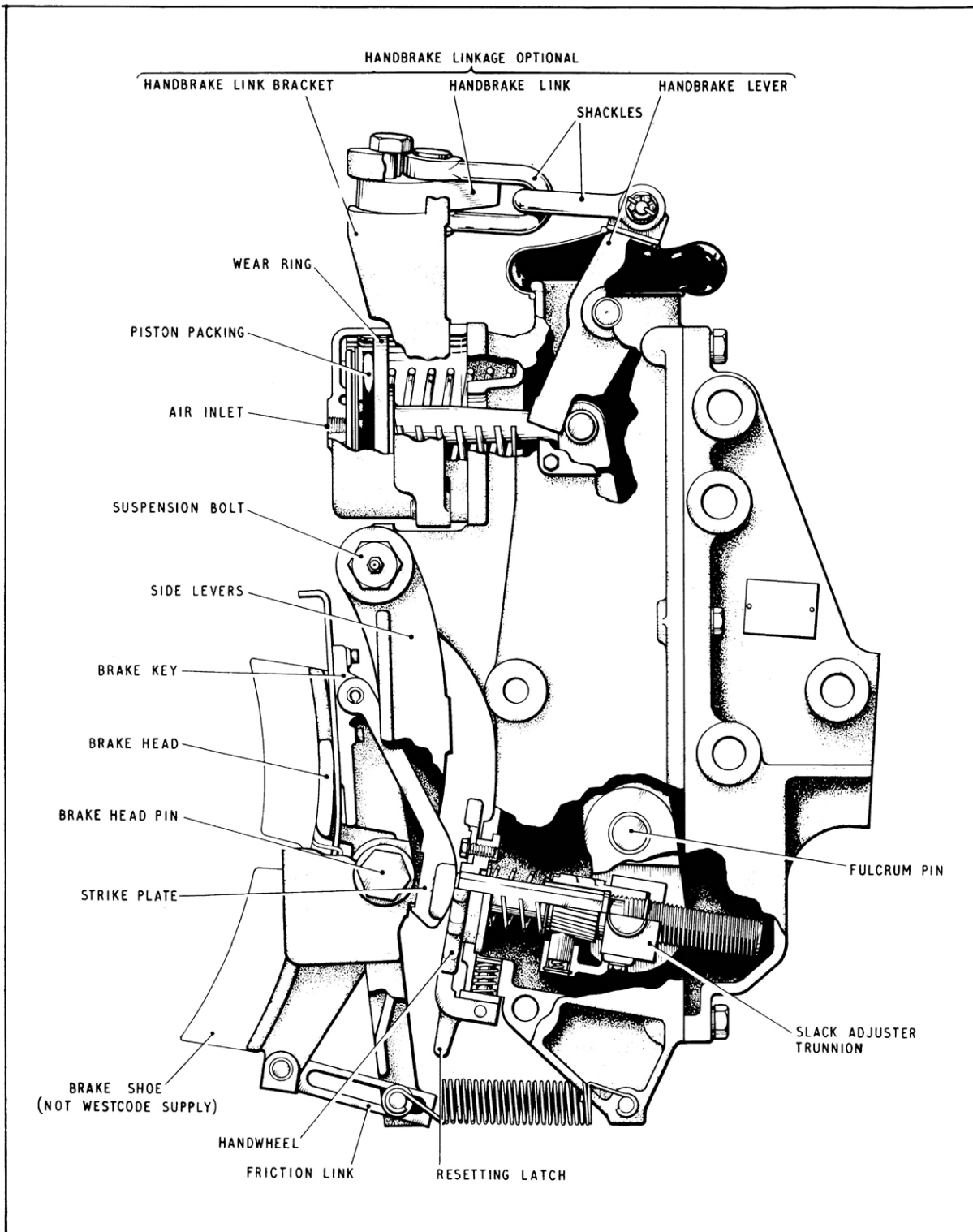

FIGURE 1-20. BRAKE SHOE INSTALLATION. E-18738



Southeastern Pennsylvania Transportation Authority
EXTERIOR MECHANICAL INSPECTION AND REPAIR
Silverliner IV MU Locomotives (Inspection per 49CFR229.23)

Resetting and Fitting New Brake Shoes

1. To reset, disengage spring-loaded latch lever from handwheel, and rotate the wheel until the slack adjuster push rod is screwed right back into the unit.
2. The shoe is attached to the brake head by the brake key. Hold the side levers and brake head against the pull-off springs, while disengaging the key to free the worn shoe, and again while fitting the key to lock the new shoe in place. The striker attached to the key fits between the back of the brake head and the front of the slack adjuster push rod.
3. When a new shoe has been fitted, the clearance between the shoe and wheel can be adjusted to the correct amount by turning the resetting wheel counterclockwise. Alternatively, the latch can be engaged with one of the U-shaped slots in the wheel, and the electro-pneumatic brake may be applied and released until a consistent push rod stroke is obtained. This should give the correct clearance automatically, and, in addition, prove the operation of the brake cylinder and slack adjuster mechanism. After resetting, always ensure the reset locking latch is properly engaged with the handwheel.

BRAKE SHOES & RUNNING REPAIRS

This procedure is contained in the GE Heavy Maintenance Manual, GEK-38312.

Silverliner IV Inspection Forms

This Page Intentionally Left Blank.



**Southeastern Pennsylvania Transportation Authority
 Periodic Inspection and Maintenance Record (per 49CFR229.23)
 Silverliner IV MU Locomotives**

--

Date: _____ **Location:** _____ **Vehicle No.** _____

INBOUND INSPECTION — INTERIOR INBOUND

NOTE: All items referred to have electric wires, conduit, pipes, brackets, bolts, shunts, nuts, studs, clamps, etc., attached. Inspection of an item includes inspection of the above-mentioned appurtenances.

LIGHTING Test the operation of all lamps, fixtures, and switches. Inspect for short circuits, burn marks, broken fixtures or lenses and frayed wiring.

1. MAIN INTERIOR COACH LIGHTS _____
2. AUXILIARY(DITCH)WARNING LIGHTS _____
3. EMERGENCY LIGHTS _____
4. HEADLIGHTS AND RESISTORS _____
 Test High and Low Beams HIGH _____ LOW _____
5. GAUGE AND CONSOLE LIGHTS _____
6. MARKER LIGHTS _____
7. NUMBER SIGN LIGHTS _____
8. VESTIBULE LIGHTS _____
9. CLEARANCE LIGHTS _____
10. OUTSIDE BRAKE INDICATOR LIGHTS _____
11. END DOOR CLOSE LIGHT OPERATION _____

COMMUNICATIONS

1. RADIO Test (TRANSMIT AND RECEIVE ON ALL CHANNELS) _____
2. PA TEST (CAB AND CENTER LOCATIONS) _____
3. BUZZERS TEST (FROM ALL LOCATIONS) _____
4. HORNS TEST (HORN SHOULD ACTIVATE DITCH LIGHTS) _____

HEAT, VENTILATION, AND AIR CONDITIONING

1. CAB WINDSHIELD HEATER BLOWER TEST: A-END _____ B-END _____
2. TEST COLLISION DOOR CAB HEAT SAFETY SWITCH: A-END _____ B-END _____
3. CAB CEILING HEATER BLOWER TEST: A-END _____ B-END _____

DOOR AND DOOR CONTROLS—MXTF—WHEEL SLIPS

1. INDIVIDUAL DOOR—OPERATIONAL TEST _____
2. TRAINLINE DOORS—OPERATIONAL TEST _____
3. CHECK DOOR INDICATOR LIGHT FOR PROPER FUNCTION: _____
4. RECORD AND RESET WHEEL SLIP COUNTERS
 A-TRUCK _____ B-TRUCK _____
5. TRANSFORMER FAN CURRENT #1 _____ amps ac #2 _____ amps ac
6. TRANSFORMER PUMP CURRENT _____ amps ac
7. MEASURE AND RECORD WHEEL SLIP SPEED SENSOR RESISTANCE:
 #1 _____ Ohms #2 _____ Ohms #3 _____ Ohms #4 _____ Ohms

REMARKS:

INSPECTOR: _____ EMPLOYEE #: _____ MANAGER: _____



**Southeastern Pennsylvania Transportation Authority
 Periodic Inspection and Maintenance Record (per 49CFR229.23)
 Silverliner IV MU Locomotives**

--

Date: _____ **Location:** _____ **Vehicle No.** _____

ELECTRIC SLIDING DOOR EMERGENCY RELEASE TEST

TEST THE EMERGENCY RELEASE MECHANISM ON EACH ELECTRIC SLIDING DOOR ON EACH SL-IV MU LOCOMOTIVE. INDICATE PASS OR FAIL IN THE SPACES PROVIDED BELOW. DOCUMENT ANY EXCEPTIONS ON [FORM PI-1037](#).

A-End Right Side	Pass	<input type="checkbox"/>	Fail	<input type="checkbox"/>
A-End Left Side	Pass	<input type="checkbox"/>	Fail	<input type="checkbox"/>
B-End Right Side	Pass	<input type="checkbox"/>	Fail	<input type="checkbox"/>
B-End Left Side	Pass	<input type="checkbox"/>	Fail	<input type="checkbox"/>

INSPECTOR: _____ EMPLOYEE #: _____ MANAGER: _____



**Southeastern Pennsylvania Transportation Authority
Periodic Inspection and Maintenance Record (per 49CFR229.23)
Silverliner IV MU Locomotives**

--

Date: _____ **Location:** _____ **Vehicle No.** _____

CAB SIGNAL INSPECTION

Type of Inspection: Periodic _____ Failure _____
 Cab Signal Test Box Calibration Due Date: _____ Cab Signal Test Box Serial Number: _____
 Actual Date: _____ OBC Date: _____ Event Recorder Date: _____
 Actual Time: _____ OBC Time: _____ Event Recorder Time: _____

Receiver Height Inspection: (6" – 9")		Initial	Final		Initial	Final
F-End Receiver	Right Side			Left Side		
R-End Receiver	Right Side			Left Side		
Receiver in-board 0–2" from the center of the rail head to the outside end of the receiver bar		Initial	Final		Initial	Final
F-End Receiver	Right Side			Left Side		
R-End Receiver	Right Side			Left Side		

Visual Inspection

ATC Receiver Coil _____
 PTC Scanner Antenna and CTV Box _____
 Roadway Worker Antenna _____
 Speed Sensor Wiring, Cables, and Connections: _____

Serial Numbers:

CTV _____
 Antennas _____
 ID Module _____

Insulation Resistance (≥ 1 Meg)	Record		Insulation Resistance (≥ 1 Meg)	Record	
ATC 32V	+	-	PTC 32V	+	-
ATC TACH (Speed Sensor)	+	-	PTC TACH (Speed Sensor)	+	-
ATC Penalty	+	-	PTC Penalty	+	-
F-End Receiver Coils			R-End Receiver Coils		
No Motion	+	-	EXT I/O 32V	+	-

ATC Voltage Check	Record		PTC Voltage Check	Record	
BATT IN (26–47VDC)			BATT IN (26–47VDC)		
ATC 32V (31–33VDC)			PTC 32V (31–33VDC)		
ATC Penalty (28–33VDC)			PTC Penalty (28–33VDC)		
EXT I/O 32V (28–33VDC)					

	F-END				R-END			
Roadway Worker System	Pass		Fail		Pass		Fail	
ATC Departure Test	Pass		Fail		Pass		Fail	
PTC Departure Test	Pass		Fail		Pass		Fail	
Audible Alarm Sound	Yes		No		Yes		No	
Delay Time from Alarm sound to emergency brake application 4.6 sec	Pass		Fail		Pass		Fail	
Low Current Signal Pickup: (Amps in rail circuit — 100 Hz Carrier and 250 Hz Carrier) 100 Hz Carrier — 1.5–1.8A 250 Hz Carrier — 0.8–1.0A	100 Hz Carrier		250 Hz Carrier		100 Hz Carrier		250 Hz Carrier	
	Initial	Final	Initial	Final	Initial	Final	Initial	Final

Check Inbound Inspection form to see if the Event Recorder fault light was illuminated: YES / NO.

Record Digital Odometer Reading: _____
 OBC Data Logger Battery Check (Use PTCView): _____ Wheel Size: _____

Software Revisions Level:

PTC View		ATC Decoder		PTC System		Comm. Controller	
ATC System		ATC Cab test		PTC Main		Lon Works	
ATC Main		ATC ADU 1		PTC I/O			
ATC I/O		ATC ADU 4		PTC Decoder			

ATC Cut-out: _____ PTC Cut-out: _____

INSPECTOR: _____ **EMPLOYEE #:** _____ **MANAGER:** _____



**Southeastern Pennsylvania Transportation Authority
 Periodic Inspection and Maintenance Record (per 49CFR229.23)
 Silverliner IV MU Locomotives**

--

Date: _____ **Location:** _____ **Vehicle No.** _____

AUXILIARY GROUP — ELECTRIC INSPECTION

NOTE: All items referred to below have electric wires, conduit, pipe brackets, bolts, nuts, studs, clamps, etc., attached. Inspection of an item includes inspection of all attachments and components that are important to its operation

1. Air Compressor Breaker _____
2. Air Compressor Contactor _____
3. Blower Breakers _____
4. All other Breakers _____
5. Motor Alternator Contactors _____
6. Equipment Fan and Blower Contactors _____
7. All other Contactors _____
8. Overload Relays _____
9. All other Relays _____
10. Fault lights operative _____
11. Visual Inspection Auxiliary Group Front/Rear _____
12. TPF Pick-up _____
13. LAR Pick-up _____
14. Buck-Boost/PMR Resistors _____
15. Buck-Boost Transformer _____
16. KM Controller and Sequence Test _____
17. R.G.R. and G.R. TEST _____ DOES G.R. TRIP? _____
18. ARE ALL CIRCUIT BREAKERS ON? _____
19. ANY FAULT LIGHTS ON? _____ WHICH ONE(S)? _____
20. CHECK AIR COMPRESSOR CONDITION and OPERATION. _____

Control Circuit Test using Test Light:

TEST LIGHT

38 Control Circuits _____
 36 Battery Circuit _____

MEGGER TESTS(INDICATE VALUES)

1500 Main Circuit _____ Ω
 600 Aux. Control _____ Ω
 220/230 Control _____ Ω
 Traction Motors A B Ω
 Dynamic Brake _____ Ω
 Dynamic Brake Controller _____

CAM CONTROL GROUP

Relays _____
 Contactors _____
 Pilot Motor _____
 Commutator _____
 Brushes _____

Electric Coupler Head B-End _____ A-End _____
 Electric head cables and safety wire condition B-end _____ A-end _____

REMARKS:

INSPECTOR: _____ **EMPLOYEE #:** _____ **MANAGER:** _____



**Southeastern Pennsylvania Transportation Authority
 Periodic Inspection and Maintenance Record (per 49CFR229.23)
 Silverliner IV MU Locomotives**

--

Date: _____ **Location:** _____ **Vehicle No.** _____

AIR COMP/MA RESISTOR INSPECTION

PERFORM THE FOLLOWING TESTS ON SL-IV CARS AS APPLICABLE.

ON SINGLE AND EVEN SL-IV ONLY

1. Test 255 Control Panel fuses:

F1 _____

F2 _____

F3 _____

2. Test SRF fuses:

SRF1 _____ SRF2 _____

SRF3 _____ SRF4 _____

3. Test Buck-Boost Resistors:

RESISTORS	TEST POINTS	CORRECT READINGS	INSPECTOR'S READINGS
BB 1, 2, 3	C TO G	3.6 OHMS	OHMS
BB 4,5,6	C TO X	3.6 OHMS	OHMS
BB 12,13	C TO D*	50.0 OHMS	OHMS
BB 11	C TO J**	0.25 OHMS	OHMS

* SBR-1 MUST BE PULLED IN

**Open SBR-1 Contact (50AM-50AG).

4. MA Running Resistors (MAR resistors)

VISUAL Inspection: _____ (Mark Good, Bad, Burnt, Replaced, Etc.).

OHM Readings:

Top Bank-6 Resistors _____ OHMS (74 ±5%).

Bottom Bank-2 Resistors _____ OHMS.

(192 ± 5% Ohms on married pairs, 340 ± 5% OHMS on single cars.).

MA Start Resistors

Visual Inspection: _____ (Mark Good, Bad, Burnt, Replaced, Etc.)

REMARKS:

INSPECTOR: _____ **EMPLOYEE #:** _____ **MANAGER:** _____



**Southeastern Pennsylvania Transportation Authority
 Periodic Inspection and Maintenance Record (per 49CFR229.23)
 Silverliner IV MU Locomotives**

--

Date: _____ **Location:** _____ **Vehicle No.** _____

**PERIODIC INSPECTION
BATTERY AND BATTERY CHARGER INSPECTION
A and Single Car Only**

1. INDICATE BATTERY MANUFACTURER: _____
2. INDICATE BATTERY CHARGER STYLE: _____
3. BATTERY CHARGER OPERATION _____
4. BATTERY CHARGER OUTPUT IN HIGH RATE (APPROX. 30 TO 40 AMPS)
 OUTPUT CURRENT AT HIGH RATE _____ AMPS
5. BATTERY CHARGER OUTPUT VOLTAGE AT FLOAT (APPROX. 37.5 VDC) & (1 -2 AMPS)
 OUTPUT VOLTAGE AT FLOAT _____ VDC _____ AMPS
6. BATTERY FUSE CONDITION _____
7. INDICATE WATER LEVEL AND CELL VOLTAGE IN THE SPACES PROVIDED

**BATTERY CELL IDENTIFICATION
2 TRAYS - 4 SETS**

6 - CELL						6- CELL											
1	2	3	4	5	6	◀ CELL IDENTIFICATION ▶						7	8	9	10	11	12
						◀ CELL, VOLTAGE ▶											
						◀ WATER LEVEL ▶											
						◀ CELL VOLTAGE ▶ WITH BRB TURNED OFF											

6 - CELL						7 - CELL									
13	14	15	16	17	18	◀ CELL IDENTIFICATION ▶			19	20	21	22	23	24	25
						◀ CELL VOLTAGE ▶									
						◀ WATER LEVEL ▶									
						◀ CELL VOLTAGE ▶ WITH BRB TURNED OFF**									

NOTES:

SL-IV CARS HAVE 25 CELLS.

CHECK BLOCK IN EACH CELL WITH THE FOLLOWING INFORMATION:

ADD WATER = A CELL VOLTAGE = Approx. 1.4 VDC
 REMOVE WATER = R CORRECT LEVEL = L

NOTE: CHECK BATTERY CELL VOLTAGE AFTER 4-5 HOURS WITH BATTERY BREAKER OFF.**.

REMARKS:

INSPECTOR: _____ EMPLOYEE #: _____ MANAGER: _____



**Southeastern Pennsylvania Transportation Authority
 Periodic Inspection and Maintenance Record (per 49CFR229.23)
 Silverliner IV MU Locomotives**

--

Date: _____ **Location:** _____ **Vehicle No.** _____

ELECTRICAL INSPECTION
RECTIFIER/MAIN GROUP INSPECTION

NOTE: All items referred to below have electric wires, conduit, pipe brackets, bolts, nuts, studs, clamps, etc., attached. Inspection of an item includes inspection of all attachments and components that are important to its operation.

RECTIFIER CONTROL GROUP:

- 1. A1 - A2 - A3 CONTACTORS _____
- 2. IGNITRON TUBES OR SCR'S _____
- 3. C1 - C2 - C3 SURGE CAPACITORS _____
- 4. PRP1 - DIODES OK _____ REPLACED _____ CLEANED _____
- 5. PRP2 - DIODES OK _____ REPLACED _____ CLEANED _____
- 6. PRP3 - DIODES OK _____ REPLACED _____ CLEANED _____
- 7. PRP4 - DIODES OK _____ REPLACED _____ CLEANED _____
- 8. F1 FUSE GOOD _____ BAD _____
- 9. F2 FUSE GOOD _____ BAD _____
- 10. F3 FUSE GOOD _____ BAD _____
- 11. F4 FUSE GOOD _____ BAD _____

MAIN CONTROL GROUP:

- 1. OLM-1 & OLM-2 _____
- 2. MA/OL (Ohms) _____
- 3. RELAYS _____
- 4. AM AND B CONTACTORS (BEHIND GROUP) _____
- 5. REVERSER _____
- 6. A1 SEQUENCE TEST _____
- 7. ROOF RESISTORS _____ OHMS ("B" CONTACTOR)
- 8. ALL WIRE CONNECTIONS, CONDUIT, AND PULL BOXES _____

ALL CARS:

- 1. HOOK STICK AND CONTAINER _____
- 2. CHECK LATCHES, HOOKS, AND WEATHER SEALS ON ALL COVERS RELATED TO YOUR INSPECTION. REPAIR IF NECESSARY. _____

REMARKS:

INSPECTOR: _____ **EMPLOYEE #:** _____ **MANAGER:** _____



**Southeastern Pennsylvania Transportation Authority
 Periodic Inspection and Maintenance Record (per 49CFR229.23)
 Silverliner IV MU Locomotives**

--

Date: _____ **Location:** _____ **Vehicle No.** _____

UNDER CAR INSPECTION
MOTOR INSPECTION

NOTE: All items referred to have electric wires, conduit, pipes, brackets, bolts, shunts, nuts, studs, clamps, etc. Inspection of an item includes inspection of the above-mentioned appurtenances.

1. Traction Motors Inspection:
 - a. Inspect and Clean Brush Holder Insulators _____
 - b. Brush Holder assembly condition _____
 - c. Traction Motor Leads and Cleats _____
 - d. Flash ring condition _____
2. Ground Cables: #1_____ #2_____ #3_____ #4_____
3. Bolster Ground Cables: A-Truck_____ B-Truck_____

*Note in the remarks section which ground cables were repaired or replaced
4. Transformer Inspection:
 - a. Ground and High-Tension Leads _____
 - b. Oil Level: Low _____ Mid _____ Max_____

If fluid is not visible in any of the sight glasses, check level outside shop with car under power.
 If level is still not visible ship to Wayne Junction shop for fluid addition.
 - c. Cooling Fans _____
 - d. Main Transformer Type and Serial Number _____
 - e. If leakage is found on any area of the transformer, ship to Wayne Junction shop for clean and repair as required. Make a note of the leakage in the "Remarks" section below.
5. Wheel Slip Sensors, cables, and connections _____
6. PTC/ATC Sensors, cables, and connections _____
7. Smoothing Reactor _____
8. Auxiliary Smoothing Reactor _____
9. Air Ducts and Hoses _____
10. Underfloor Resistors and Insulators _____
11. Rubber Resilient Mounts _____
12. (MARRIED PAIR ONLY)
 Check Trainline Jumpers J1-J6 Secured and Safety Wired: _____

(MA, BMA, SEB, Air Compressor, Air Conditioning Unit, Transformer and Rectifier Cooling Fans).

REMARKS:

INSPECTOR: _____ **EMPLOYEE #:** _____ **MANAGER:** _____



**Southeastern Pennsylvania Transportation Authority
 Periodic Inspection and Maintenance Record (per 49CFR229.23)
 Silverliner IV MU Locomotives**

--

Date: _____ **Location:** _____ **Vehicle No.** _____

TRACTION MOTOR INSPECTION

MINIMUM BRUSH LENGTHS

Change all brushes if any are at or below minimum length:

- Silverliner IV 1259 Traction Motors: 1-3/4"
- All Axle Ground Brushes: 1-3/8"

Motor	Brush Condition and Length	Brush Replaced
#1		Yes / No
#2		Yes / No
#3		Yes / No
#4		Yes / No

GROUND BRUSH MEASUREMENTS	#1	#2	#3	#4
---------------------------	----	----	----	----

REMARKS:

INSPECTOR: _____ **EMPLOYEE #:** _____ **MANAGER:** _____



**Southeastern Pennsylvania Transportation Authority
 Periodic Inspection and Maintenance Record (per 49CFR229.23)
 Silverliner IV MU Locomotives**

--

Date: _____ **Location:** _____ **Vehicle No.** _____

BRUSH & COMMUTATOR REPORT

- Record measurements of previous brush and replace.

BRUSH & COMMUTATOR REPORT

MOTOR	Brush Condition and Length	Brush Replaced	Serial Number, Vendor, & Job Date
BMA		Yes / No	
SEB		Yes / No	

REMARKS:

INSPECTOR: _____ **EMPLOYEE #:** _____ **MANAGER:** _____



**Southeastern Pennsylvania Transportation Authority
 Periodic Inspection and Maintenance Record (per 49CFR229.23)
 Silverliner IV MU Locomotives**

--

Date: _____ **Location:** _____ **Vehicle No.** _____

ROOF INSPECTION

NOTE: All items referred to have electric wires, conduit, pipes, brackets, bolts, shunts, nuts, studs, clamps, etc., attached. Inspection of an item includes inspection of the above-mentioned appurtenances.

ALL CARS:

1. TRANSFORMER CABLE _____
2. INSULATORS (INSPECT AND CLEAN) _____
3. CURRENT TRANSFORMER _____
4. ROOF FUSE _____
5. DANGER SIGNS (INSPECT AND CLEAN) _____
6. DYNAMIC BRAKE ROOF RESISTORS CONDITION _____
7. ANTENNAS _____
8. ROOF CONDITION — CHECK FOR HOLES, DEBRIS, ETC. _____
9. TRAINLINE: UP BUTTON _____ DOWN SWITCH _____
10. AUTOMATIC GROUND SWITCH (PLR OPERATION) _____

SINGLE CARS AND ODD NUMBERED CARS OF A MARRIED UNIT:

11. PANTOGRAPH SHOE AND WEARING STRIPS _____
12. PANTOGRAPH HORNS _____
13. PANTOGRAPH DOWN CYLINDER _____
14. PANTOGRAPH UNLATCH CYLINDER _____
15. PANTOGRAPH LUBRICATION _____
16. PANTOGRAPH SPRING TENSION _____
17. PANTOGRAPH CAMERA (INSPECT AND CLEAN) _____
18. GROUND SWITCH AND LOCK DOWN HOOK ASSEMBLY _____
19. GROUND SWITCH CABLE _____
20. AIR LINES (INSPECT AND CLEAN) _____
21. LIGHTNING ARRESTER _____
22. PANTOGRAPH HAND PUMP _____
23. PANTOGRAPH TESTED AT PNEUMATIC VALVES: UP _____ DOWN _____
24. INSPECT AND CLEAN REFLECTOR TAPE. REPLACE IF NEEDED. _____
25. REPORT STEPLADDER, FOOTHOLDS AND HANDHOLDS CONDITION _____
26. INSTALL SAFETY PIN IN HOLDER. _____

NOTE: THE PANTOGRAPH BALCONY, HOIST, CAT WALKS, ETC., ARE PI LINE RESPONSIBILITIES. IT IS YOUR DUTY TO KEEP THOSE AREAS WELL ORGANIZED AND CLEAN.

REMARKS:

INSPECTOR: _____ **EMPLOYEE #:** _____ **MANAGER:** _____



**Southeastern Pennsylvania Transportation Authority
 Periodic Inspection and Maintenance Record (per 49CFR229.23)
 Silverliner IV MU Locomotives**

--

Date: _____ **Location:** _____ **Vehicle No.** _____

HVAC INSPECTION

PERFORM FOLLOWING CIRCUIT TESTS & MAKE NECESSARY REPAIRS

Test Points

<u>Component Tested</u>	<u>TB 831</u>	<u>TB 832</u>	<u>Correct Value</u>	<u>Value Found</u>
O/HEAT 1ST B/E	81 AD	81 AB	25 OHMS + 3	_____
O/HEAT 2ND B/E	81 BD	81 BB	25 OHMS + 3	_____
O/HEAT 1ST A/E	81 CD	81 CB	25 OHMS + 3	_____
O/HEAT 2ND A/E	81 DD	81 DB	25 OHMS + 3	_____
FLOOR HEAT 1ST	81 EC	81 EB	25 OHMS + 3	_____
FLOOR HEAT 2ND	81 FC	81 FB	25 OHMS + 3	_____
CAB HEAT 1ST B/E 81 GD	81 GB	OLD 165 OHMS + 5 NEW 180 OHMS + 5		_____
CAB HEAT 2ND B/E 81 GD	81 GC	OLD 165 OHMS + 5 NEW 180 OHMS + 5		_____
CAB HEAT 1ST A/E 81 HD	81 HB	OLD 165 OHMS + 5 NEW 180 OHMS + 5		_____
CAB HEAT 2ND A/E 81 HD	81 HC	OLD 165 OHMS + 5 NEW 180 OHMS + 5		_____

PROTECTIVE HEAT CHECK

Place a jumper from TB-873 on the PC Board (80+003), to the J2 receptacle pin "S". Physically inspect auto drain dryer and air compressor sump tank heaters for proper operation. Make all necessary repairs to the heat circuits.

PROTECTIVE HEAT CONDITION AND OPERATION: Good: _____ Bad: _____ Initial: _____
 CLEAN CONDENSER COILS _____
 CLEAN MTFX AFTER COOLER _____

REMARKS:

INSPECTOR: _____ **EMPLOYEE #:** _____ **MANAGER:** _____



**Southeastern Pennsylvania Transportation Authority
 Periodic Inspection and Maintenance Record (per 49CFR229.23)
 Silverliner IV MU Locomotives**

--

Date: _____ **Location:** _____ **Vehicle No.** _____

HVAC INSPECTION – CONT

Electrical Inspection

Inspect all ports and service valves, evaporators, condensers, control box for leaks	Yes/No
Inspection of the following contactors: RCMC, CFMS, BFSA, & BFSB	Yes/No
Visual inspection on all electrical connections, contactors, terminals, sensors, etc.	Yes/No
Inspect expansion valves and solenoids	Yes/No
Check TCU for faults	Yes/No

TCU Temperature Readings

Ambient _____ Return Air _____ Outlet Duct _____

HVAC Compressor Checks

Record high side pressure		
Record low side pressure		
Record low pressure switch value	Open	Closed
Record modulation pressure switch value	Open	Closed
Check oil level on compressor. Indicate full, low, or empty		
Check Freon level at site glass. Indicate full, low, or empty		

REMARKS:

INSPECTOR: _____ **EMPLOYEE #:** _____ **MANAGER:** _____



**Southeastern Pennsylvania Transportation Authority
 Periodic Inspection and Maintenance Record (per 49CFR229.23)
 Silverliner IV MU Locomotives**

--

Date: _____ **Location:** _____ **Vehicle No.** _____

WHEELS, MECHANICAL EQUIPMENT AND SAFETY APPLIANCE
PERIODIC INSPECTION

This inspection must be performed at every Periodic Inspection in accordance with 49CFR229. The inspector will inspect all items that fall into the categories of Running Gear, Mechanical Equipment, and Safety Appliances and sign Form FRA 6180-49 A indicating that Items 2, 4, and 7 were inspected and that any defects have been repaired or reported for repair prior to the vehicle being made available for revenue service.

All defects found during the Periodic Inspection must be noted on [Form PI-1026](#) Defect Report, [Form PI-1026](#) Wheel Inspection Report and/or on a VMIS Work Order. Inspection must include but is not limited to the following itemized list. After each item description, indicate the condition of each item. Indicate whether the item is in OK, DEFECTIVE or NON-COMPLYING condition. If an item is found to be in non-compliance with 49CFR229, 49CFR238 or any published FRA, APTA or SEPTA standards, make note on this form under DOCUMENT what form was submitted detailing the defects. Record Wheel Readings on [Form PI-1026](#) Wheel Inspection Report. Report minor defects on [PI-1026](#) Mechanical Exterior Inspection Report. Record major defects on a VMIS Work Order.

DESCRIPTION OF ITEMS OR AREAS TO BE INSPECTED	CONDITION	INITIALS
Inspect Foundation Brake Gear.		
Inspect Draft System, Couplers, Buffers and Associated Components.		
Inspect for signs and/or causes of lateral motion.		
Inspect for signs of defective or overheated bearings.		
Inspect all suspension system springs.		
Inspect trucks and associated components for wear, breaks, cracks, etc.		
Inspect all traction motor suspension bolts, safety support clearances and all cotter pins.		
Inspect side bearings for proper clearance, wear, cracks, breaks, etc.		
Inspect vehicle for proper clearance above the rail.		
Inspect Wheel Sets, Axles, Gear Units, and Traction Motors.		
Measure and record Wheel Readings.		
Inspect wheels for defects.		
Inspect Doors, Steps, exterior cabinets, covers, etc.		
Inspect Pilots, End Plates and associated components.		
Measure coupler, Truck, Air Spring, Bolster, Buffer, and Floor heights from rail. Inspect Shocks.		
Inspect vehicle exterior, underfloor, and structural components.		

REMARKS:

INSPECTOR: _____ **EMPLOYEE #:** _____ **MANAGER:** _____



**Southeastern Pennsylvania Transportation Authority
 Periodic Inspection and Maintenance Record (per 49CFR229.23)
 Silverliner IV MU Locomotives**

--	--

Date: _____ **Location:** _____ **Vehicle No.** _____

Wheel Inspection Report

Position	Flange		Rim Thickness	Side Bearing Clearance	Brake Rigging	Snubber Condition	EQ Spring Condition	Air Spring 9"-9 3/4"	
	Height	Thickness						Height	Condition
RIGHT SIDE								"F" Right Side	
	2								
	4								
	6							"A" Right Side	
	8								
LEFT SIDE								"F" Left Side	
	1								
	3								
	5							"A" Left Side	
	7								

	Front End	Rear End	Passenger Limits	
COUPLER HEIGHT			34" Min., 35" Max	
COUPLER TO BUFFER			16" Min., 17" Max	
BUFFER HEIGHT			50" Min., 52" Max	BUFFER TO BUFFER HEIGHT < 1"
PILOT/PLOW HEIGHT			3" Min., 6" Max	
SIDE BEARING TO RAIL *TRUCK HEIGHTS	Right	Left	Right	Left
			24 15/16" MIN 25 15/16" MAX	Back-to-Back 53-1/16 to 53-5/16
			#1	#2 #3 #4

<table border="1" style="font-size: small;"> <tr><th>A</th><th>1/16</th></tr> <tr><td>0 AT 22</td><td>1.375 22</td></tr> <tr><td>0 AT 21</td><td>1.313 21</td></tr> <tr><td>0 AT 20</td><td>1.250 20</td></tr> <tr><td>0 AT 19</td><td>1.188 19</td></tr> <tr><td>0 AT 18</td><td>1.125 18</td></tr> <tr><td>0 AT 17</td><td>1.063 17</td></tr> </table> <p align="center">FLANGE HEIGHT MEASUREMENT</p>	A	1/16	0 AT 22	1.375 22	0 AT 21	1.313 21	0 AT 20	1.250 20	0 AT 19	1.188 19	0 AT 18	1.125 18	0 AT 17	1.063 17	<table border="1" style="font-size: small;"> <tr><th>AT</th><th>B</th></tr> <tr><td>0</td><td>1.264</td></tr> <tr><td>2</td><td>1.210</td></tr> <tr><td>3</td><td>1.168</td></tr> <tr><td>4</td><td>1.120</td></tr> <tr><td>5</td><td>1.070</td></tr> <tr><td>6</td><td>1.034</td></tr> <tr><td>7</td><td>0.995</td></tr> <tr><td>8</td><td>0.951</td></tr> <tr><td>9</td><td>0.894</td></tr> </table> <p align="center">FLANGE THICKNESS MEASUREMENT</p> <p align="center">METHOD TO MEASURE WHEEL THICKNESS MEASURING POINT</p>	AT	B	0	1.264	2	1.210	3	1.168	4	1.120	5	1.070	6	1.034	7	0.995	8	0.951	9	0.894	<p align="center">METHOD TO MEASURE VERTICAL FLANGE</p> <p align="center">TO CONDEMN WHEEL, MEASURING POINT MUST TOUCH FLANGE</p>	<p align="center">METHOD TO MEASURE BROKEN RIM — HEAVY FLANGE</p> <p align="center">METHOD TO MEASURE FLAT AND SHELL SPOTS FRA MAX. 2 1/2"</p> <p align="center">METHOD TO MEASURE FLANGE THICKNESS</p>
A	1/16																																				
0 AT 22	1.375 22																																				
0 AT 21	1.313 21																																				
0 AT 20	1.250 20																																				
0 AT 19	1.188 19																																				
0 AT 18	1.125 18																																				
0 AT 17	1.063 17																																				
AT	B																																				
0	1.264																																				
2	1.210																																				
3	1.168																																				
4	1.120																																				
5	1.070																																				
6	1.034																																				
7	0.995																																				
8	0.951																																				
9	0.894																																				

NOTE: If any measurements are not within spec, please notify your manager.

INSPECTOR: EMPLOYEE #:	MANAGER:
----------------------------------	-----------------



**Southeastern Pennsylvania Transportation Authority
 Periodic Inspection and Maintenance Record (per 49CFR229.23)
 Silverliner IV MU Locomotives**

--

Date: _____ **Location:** _____ **Vehicle No.** _____

MECHANICAL — EXTERIOR RUNNING REPAIRS

REPAIRS	CORRECTIVE ACTION	SIGNATURE AND EMPLOYEE NUMBER
LUBRICATE HANDBRAKE AND TEST HANDBRAKE OPERATION		
REPLACE WORN BRAKE SHOES		
TEST/LUBE LOCK BLOCK ASSY		
INSTALL BODY PLUGS		
T-BARS INSTALLED		

THE ABOVE WORK HAS BEEN PERFORMED, EXCEPT AS NOTED, AND THE REPORT IS APPROVED.

MANAGER: _____



**Southeastern Pennsylvania Transportation Authority
 Periodic Inspection and Maintenance Record (per 49CFR229.23)
 Silverliner IV MU Locomotives**

--

Date: _____ **Location:** _____ **Vehicle No.** _____

AIR INSPECTION FORM

NOTE: All items referred to have electric wires, conduit, pipes, brackets, bolts, shunts, nuts, studs, clamps, etc., attached. Inspection of an item includes inspection of the above mentioned appurtenances.

TEST/CALIBRATE GAUGES

Main Reservoir:	A-END _____ psi	B-END _____ psi
Equalizing Reservoir:	A-END _____ psi	B-END _____ psi
Brake Pipe:	A-END _____ psi	B-END _____ psi
Brake Cylinder:	A-END _____ psi	B-END _____ psi

INSPECT & TEST AIR BRAKE SYSTEM

Full Service A-End _____ B-End _____	Brake Pipe Leakage A-End _____ B-End _____
Emergency Service A-End _____ B-End _____	Brake Cyl Leakage A-End _____ B-End _____
Snow Brake Pressure A-End _____ B-End _____	Main Res Leakage A-End _____ B-End _____
Single-Car Brake A-End _____ B-End _____	Control Res Leakage A-End _____ B-End _____

TESTS AND INSPECTIONS:

Tread Brake Units (INCLUDING A 'WALKING' RELEASE AND APPLICATION) A-END _____ B-END _____

Leveling Valves A-END _____ B-END _____

Air Springs A-END _____ B-END _____

Main Reservoir Poppet Valve A-END _____ B-END _____

Brake Pipe Poppet Valve A-END _____ B-END _____

Deadman Operation Test: A-END _____ B-END _____

Check Gauge and Indicating Lights A-END _____ B-END _____

Window Wipers (Complete) A-END _____ B-END _____

Check Horn Condition, Operation and Dust Covers A-END _____ B-END _____

Check Brake Valve Condition and Operation A-END _____ B-END _____

Test Electro-pneumatic Brake Functions A-END _____ B-END _____

Emergency and Variable Load Valve Test A-END _____ B-END _____

Inspect and Test All Cut-out Cocks _____

Air Strainers and Dirt Collectors _____

Regulating Valves _____

Uncoupling Valves _____

Automatic Drain Valves _____

Compressor Governor _____

Reservoir Condition _____

Hoses, Couplings, and Wasp Protectors _____

INSPECTOR: _____ **EMPLOYEE #:** _____ **MANAGER:** _____



Southeastern Pennsylvania Transportation Authority
Periodic Inspection and Maintenance Record (per 49CFR229.23)
Silverliner IV MU Locomotives

--

Date: _____ **Location:** _____ **Vehicle No.** _____

INTERIOR MECHANICAL INSPECTION

OPERATOR'S COMPARTMENT/VESTIBULE:

- WEATHERSTRIPPING A-END _____ B-END _____
 - SUN VISORS A-END _____ B-END _____
 - ALL WINDOWS AND DOOR SEALS A-END _____ B-END _____
 - ENGINEER'S SEAT A-END _____ B-END _____
 - PLATFORM DECKPLATE A-END _____ B-END _____
 - BUFFER PLATES AND PINS A-END _____ B-END _____
 - SAFETY CHAINS A-END _____ B-END _____
 - GRABIRONS A-END _____ B-END _____
 - DIAPHRAGMS A-END _____ B-END _____
 - HEADLIGHT LENS AND RUBBER A-END _____ B-END _____
 - DESTINATION SIGN BOXES A-END _____ B-END _____
 - CLEAN RETURN AIR GRILLS A-END _____ B-END _____
 - TRAP DOOR CONDITION AND OPERATION A-END _____ B-END _____
 - DOOR LATCH CONDITION AND OPERATION A-END _____ B-END _____
 - SPACER, SNUBBER AND DOOR STOPS A-END _____ B-END _____
 - INSPECT AND LUBRICATE COLLISION DOOR A-END _____ B-END _____
- TRAP DOOR SPRING TENSION: DOOR MUST RAISE 6" TO 10" WHEN DOWN LATCH IS RELEASED.
 TRAP DOOR DOWN LATCH MUST SECURE TRAP AND ENGAGE PROXIMITY SWITCH.
 FIRE EXTINGUISHER: CONDITION _____

Serial # _____ Yearly Date _____

PASSENGER COMPARTMENT:

- MAIN DOORS AND LOCKS A-END _____ B-END _____
- DOOR CHECKS A-END _____ B-END _____
- DOOR CLOSERS A-END _____ B-END _____
- BODY-END DOOR SOLENOID OPERATION A-END _____ B-END _____
- REPLACE AIR VENTILATION FILTERS A-END _____ B-END _____
- LUBRICATE AND TEST ALL CONTROL DOORS _____
- LUBRICATE AND TEST ALL PENCIL LOCKS, AND KEY LOCKS _____
- SEATS AND ARMRESTS _____
- SEAT FRAMES (CHECK FOR LOOSE SEAT FRAMES) _____
- EMERGENCY TOOLS AND PLEXIGLASS COVER _____
- FLOORING _____
- CHECK ALL DECALS INSIDE AND OUTSIDE _____
- PASSENGER WINDOWS AND SPALL SHIELDS _____
- EMERGENCY WINDOWS & HANDLES TESTED#1 _____ #2 _____ #3 _____ #4 _____
- FUSEES AND TORPEDOES INSTALLED _____
- WALL PANELS _____
- OVERHEAD DOORS, PANELS AND VENTS _____
- BAGGAGE RACKS _____
- COAT HOOKS _____
- CHECK FOR LOOSE SCREWS _____
- GRAFFITI AND VANDALISM _____
- ADVERTISEMENT SIGNS (REMOVE IF VANDALIZED) _____
- INTERIOR SIGNS, DECALS, WARNINGS, INSTRUCTIONS & LOGOS _____
- LUBRICATE ANEMOSTAT AND DOOR RODS (A & B GE ONLY) _____
- NUMBER SIGNS A & B ENDS _____
- CHECK CONDITION FLOOR BASEBOARD HEATER COVERS _____
- FOR FLOURESCENT NUMBER SIGN SIDE PANELS AND LIGHTS A & B CHECK THAT ALL SIX MOUNTING SCREWS ARE
 INSTALLED AND THAT THE PANEL IS SECURE. A-END _____ B-END _____

REMARKS:

INSPECTOR: _____ **EMPLOYEE #:** _____ **MANAGER:** _____



**Southeastern Pennsylvania Transportation Authority
Periodic Inspection and Maintenance Record (per 49CFR229.23)
Silverliner IV MU Locomotives**

--

Date: _____ **Location:** _____ **Vehicle No.** _____

INSPECTOR'S DESTINATION SIGN CHECKLIST

The following twenty-three (23) signs constitute one (1) package. Four (4) packages will be placed in each single car — two complete sets in each destination sign box or storage location. Two (2) packages will be placed in the destination sign box on each car of a married pair. Place your initials in the space provided to indicate that each sign is in place.

ITEM #	SIGN DESCRIPTION	SIDE	STOCK #	AMOUNT
1	CENTER CITY WILLIAM H. GRAY III 30TH ST.	A	54-07995-R01	
	CHESTNUT HILL EAST VIA CENTER CITY	B		
2	LINK BELT VIA CENTER CITY	A	54-07995-R23	
	MALVERN VIA CENTER CITY	B		
3	PAOLI LTD VIA CENTER CITY	A	54-07995-R03	
	BRYN MAWR VIA CENTER CITY	B		
4	TRENTON VIA CENTER CITY	A	54-07995-R04	
	TRENTON VIA CENTER CITY EXP	B		
5	AIRPORT VIA CENTER CITY	A	54-07995-R05	
	GLENSIDE VIA CENTER CITY	B		
6	CHESTNUT HILL WEST VIA CENTER CITY	A	54-07995-R06	
	FOX CHASE VIA CENTER CITY	B		
7	NORRISTOWN VIA CENTER CITY	A	54-07995-R07	
	MARCUS HOOK VIA CENTER CITY	B		
8	CENTER CITY SUBURBAN STATION	A	54-07995-R08	
	CYNWYD	B		
9	CLAYMONT, DE VIA CENTER CITY	A	54-07995-R09	
	WILMINGTON, DE VIA CENTER CITY	B		
10	THORNDALE VIA CENTER CITY	A	54-07995-R10	
	THORNDALE VIA CENTER CITY EXP.	B		
11	CENTER CITY TEMPLE UNIVERSITY	A	54-07995-R11	
	THORNDALE VIA CENTER CITY LTD	B		
12	PAOLI VIA CENTER CITY	A	54-07995-R12	
	PAOLI VIA CENTER CITY EXP	B		
13	MEDIA/WAWA VIA CENTER CITY	A	54-07995-R13	
	MEDIA/WAWA VIA CENTER CITY EXP	B		
14	NEWARK, DE VIA CENTER CITY	A	54-07995-R14	
	NEWARK, DE VIA CENTER CITY EXP	B		
15	WEST TRENTON VIA CENTER CITY	A	54-07995-R15	
	AIRPORT VIA CENTER CITY	B		
16	CENTER CITY TEMPLE UNIVERSITY	A	54-07995-R16	
	MALVERN VIA CENTER CITY	B		
17	DOYLESTOWN VIA CENTER CITY	A	54-07995-R17	
	DOYLESTOWN VIA CENTER CITY EXP	B		
18	WEST TRENTON VIA CENTER CITY	A	54-07995-R18	
	WEST TRENTON VIA CENTER CITY EXP	B		
19	AIRPORT VIA CENTER CITY	A	54-07995-R19	
	WARMINSTER VIA CENTER CITY	B		
20	LANSDALE VIA CENTER CITY	A	54-07995-R20	
	CENTER CITY WILLIAM H. GRAY III 30TH ST.	B		
21	OFF DUTY	A	54-07995-R21	
	OFF DUTY	B		
22	MEDIA VIA CENTER CITY	A	54-07995-R22	
	CHESTNUT EAST VIA CENTER CITY	B		
23	AIRPORT VIA CENTER CITY	A	54-07995-R02	
	JENKINTOWN-WYNCOTE VIA CENTER CITY	B		

INSPECTOR: _____ **EMPLOYEE #:** _____ **MANAGER:** _____



**Southeastern Pennsylvania Transportation Authority
 Periodic Inspection and Maintenance Record (per 49CFR229.23)
 Silverliner IV MU Locomotives**

--

Date: _____ **Location:** _____ **Vehicle No.** _____

GEAR UNIT OIL INSPECTION REPORT

NOTE: All items referred to have electric wires, conduit, pipes, brackets, bolts, shunts, nuts, studs, clamps, etc., attached. Inspection of an item includes inspection of the above-mentioned appurtenances.

GEAR UNITS (NOTE: Gear units use 80/90w gear oil.)

*RECORD OIL LEVEL NOTE IF EMPTY		OBTAIN OIL SAMPLE		OIL CHANGE		RECORD GEAR UNIT SERIAL NUMBERS	
#1 G.U.		#1 G.U.		#1 G.U.		#1 G.U.	
#2 G.U.		#2 G.U.		#2 G.U.		#2 G.U.	
#3 G.U.		#3 G.U.		#3 G.U.		#3 G.U.	
#4 G.U.		#4 G.U.		#4 G.U.		#4 G.U.	

* Oil level must be checked at every Periodic Inspection. Oil should be visible at fill plug.
 If gear unit is empty, note that in table above, and inform immediate supervisor of the condition.

NOTE: Assure the gear units are FILLED WHEN OIL IS VISIBLE in the fill plug hole. RETURN THE FILL PLUG to the hole and TIGHTEN THE FILL PLUG. Assure SAFETY WIRES and SAFETY STRAPS are in place on INSPECT the gear units for OIL LEAKS & CHECK BREATHER CAPS.

REMARKS:

INSPECTOR: _____ EMPLOYEE #: _____ MANAGER: _____



**Southeastern Pennsylvania Transportation Authority
 Periodic Inspection and Maintenance Record (per 49CFR229.23)
 Silverliner IV MU Locomotives**

--

Date: _____ **Location:** _____ **Vehicle No.** _____

AIR COMPRESSOR OIL LEVEL INSPECTION REPORT
B CAR AND SINGLE CAR ONLY

1. *Refill to proper level at every inspection.*
2. *Air filters must be replaced every inspection.*
3. *All Air Compressor Units use 10W/30 viscosity oil.*

D4 AIR COMPRESSOR SERIAL NUMBER: _____

D4 AIR COMPRESSOR DUE DATE: _____

Air intake filter renewed. _____

AIR COMPRESSOR OIL CHANGE (yearly as scheduled):

1.Oil changed. _____

2.Oil refilled to mark _____

3.Oil filter changed _____

ANNUAL DESICCANT DRIER RENEWAL:

Change Desiccant Beads and Worn or Broken Parts: _____

AIR COMPRESSOR CHECK:

AT EVERY PERIODIC INSPECTION, the entire air compressor unit must be inspected for oil leaks. Included are hoses, check valves, oil filter, oil cooler, after cooler, bypass valves, pumps, reservoirs, and sight glasses.

REMARKS:

INSPECTOR: _____ EMPLOYEE #: _____ MANAGER: _____



**Southeastern Pennsylvania Transportation Authority
 Periodic Inspection and Maintenance Record (per 49CFR229.23)
 Silverliner IV MU Locomotives**

--

Date: _____ **Location:** _____ **Vehicle No.** _____

MODIFICATIONS AND PROJECTS. Perform modifications or projects when directed by Periodic Inspection Line Manager.
 Instructions for modifications and/or projects may be found in one or more of the following documents:

- SEPTA Heavy Maintenance Manual GEK-38312
- SEPTA Engineering Change Notices
- SEPTA Maintenance Instructions
- Rail Mechanical Department Tech Notes
- Vehicle Modification or Project Instructions

Many of the projects are annual adjustments, checks or lubrication procedures which require a working knowledge of the vehicle and as well as mechanical or electrical commensurate with the general knowledge base of a qualified and experienced technician. If you are not familiar with the procedure you have asked to perform, see your immediate supervisor for instructions.

ELECTRICAL MODIFICATIONS AND PROJECTS

	<u>Project Description</u>	<u>Completed/Incomplete</u>	<u>Initials</u>
1.	_____	_____	_____
2.	_____	_____	_____
3.	_____	_____	_____
4.	_____	_____	_____

MECHANICAL MODIFICATIONS AND PROJECTS

	<u>Project Description</u>	<u>Completed/Incomplete</u>	<u>Initials</u>
1.	_____	_____	_____
2.	_____	_____	_____
3.	_____	_____	_____
4.	_____	_____	_____
5.	_____	_____	_____
6.	_____	_____	_____
7.	_____	_____	_____
8.	_____	_____	_____

REMARKS

INSPECTOR: _____ **EMPLOYEE #:** _____
INSPECTOR: _____ **EMPLOYEE #:** _____ **MANAGER:** _____

Silverliner IV

Yearly, A, B, C, & D Inspection Worksheets

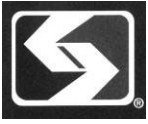

SOUTHEASTERN PENNSYLVANIA TRANSPORTATION AUTHORITY
PERIODIC INSPECTION AND MAINTENANCE RECORD

ADDITIONAL SEASONAL ITEMS
A INSPECTION (JANUARY-FEBRUARY-MARCH)

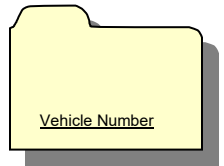

DATE STARTED: _____

DATE COMPLETED: _____

DATE	DESCRIPTION	REMARKS	SIGNATURE
	Open, clean, and Inspect Pull Box 10		
	Paint Trap Door Latches		
	Lubricate Master Controller		
	Calibrate Emergency Pressure Switch		
	BMA Overload Adjustment		
	Install, Inspect Pantograph Sash Chain		
	"A" Overload Adjustment		

Maintenance Manager: _____ Assistant Director: _____

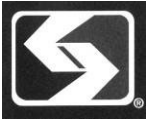

**SOUTHEASTERN PENNSYLVANIA TRANSPORTATION AUTHORITY
PERIODIC INSPECTION AND MAINTENANCE RECORD**

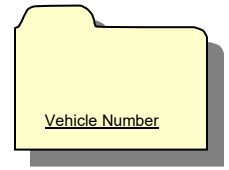

**ADDITIONAL SEASONAL ITEMS
B INSPECTION (APRIL - MAY - JUNE)**

DATE STARTED: _____

DATE COMPLETED: _____

DATE	DESCRIPTION	REMARKS	SIGNATURE
	Calibrate Brake Pipe Pressure Switch	Pickup: _____ PSI Dropout: _____ PSI	
	Calibrate C/S Low & High-Pressure Switch	Pickup: _____ PSI Dropout: _____ PSI	
	Perform Notch Interlock Calibration on SLIV KM Controller		
	Replace Pantograph Air Hoses		
	Replace (3) Breathers on Pan Assembly		
	Lubricate Shunk Pantograph Guide Piston Assembly		
	Lubricate DEB Motor Assembly		

Maintenance Manager: _____ Assistant Director: _____



**SOUTHEASTERN PENNSYLVANIA TRANSPORTATION AUTHORITY
 PERIODIC INSPECTION AND MAINTENANCE RECORD
 ADDITIONAL SEASONAL ITEMS
 C INSPECTION (JULY – AUGUST - SEPTEMBER)**

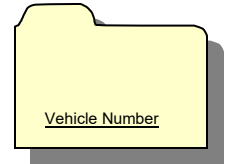

DATE STARTED: _____

DATE COMPLETED: _____

DATE	DESCRIPTION	REMARKS	SIGNATURE
	Seal Brake Valve Exhaust Hose at Floor		
	Perform P-3 Pot Dynamic Brake Test & Calibration		
	Calibrate Uncoupling Pressure Switch	Pickup: _____ PSI Dropout: _____ PSI	
	Calibrate Dyn Brake Pressure Switch	Pickup: _____ PSI Dropout: _____ PSI	
	Lubricate Air Relay P/S Fittings		
	Check Drain heaters & PHT Pickup		
	Heat Checks – Check Resistance Readings		

Maintenance Manager: _____ Assistant Director: _____



SOUTHEASTERN PENNSYLVANIA TRANSPORTATION AUTHORITY
PERIODIC INSPECTION AND MAINTENANCE RECORD
ADDITIONAL SEASONAL ITEMS
D INSPECTION (OCTOBER – NOVEMBER - DECEMBER)

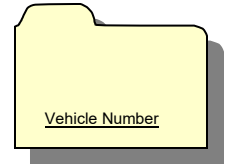

DATE STARTED: _____

DATE COMPLETED: _____

Maintenance Manager: _____

Assistant Director: _____

DATE	DESCRIPTION	REMARKS	SIGNATURE
	Air Compressor Oil & Filter Change		
	Air Compressor Desiccant Drier Renewal		
	Inspect and Calibrate N-2-A Coupler Heads		
	Calibrate A/E Brake Cylinder Pressure Switch	Pickup: _____ PSI Dropout: _____ PSI	
	Calibrate B/E Brake Cylinder Pressure Switch	Pickup: _____ PSI Dropout: _____ PSI	
	Calibrate Deadman Pressure Switch	Pickup: _____ PSI Dropout: _____ PSI	
	Calibrate Governor Pressure Switch	Pickup: _____ PSI Dropout: _____ PSI	
	Adjust Pantograph Camera		

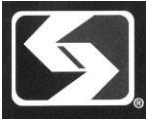

SOUTHEASTERN PENNSYLVANIA TRANSPORTATION AUTHORITY
 PERIODIC INSPECTION AND MAINTENANCE RECORD
ADDITIONAL SEASONAL ITEMS
SL-IV ANNUAL INSPECTION

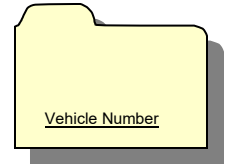

DATE STARTED: _____

DATE COMPLETED: _____

DATE	DESCRIPTION	REMARKS	SIGNATURE
	Event Recorder Download		
	Ground Relay Calibration & Test		
	SL-IV Wheel Slip Test including New Car Presence Test and DBOR Test		
	Calibrate Load Meter (SLIV)		
	SLIV Car Body Door Glide Adjustment (ALL 4 DOOR LOCATIONS)		
	Inspect/Replace Leaf Guards		
	Lubricate Hand Brake Wheel Assembly		
	Calibrate Main Reservoir Gauge	A END: _____ PSI B END: _____ PSI	
	Calibrate Brake Pipe Gauge	A END: _____ PSI B END: _____ PSI	

Maintenance Manager: _____ Assistant Director: _____