

## TECHNICAL DATA SHEET

## 400 CONTROL SWITCHES

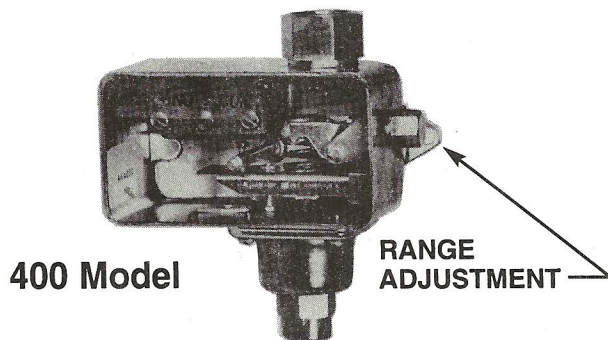

400 Model

RANGE  
ADJUSTMENT

400 Series controls are pressure or temperature actuated electrical control switches available in either one, two, three or four switch models. SPDT is standard.

Multi-switch controls may be set to actuate either simultaneously or in a sequence operation. Factory setting is available.

### INSTALLATION

Do not attach a pressure or direct connection temperature control by turning the case. Use a wrench on the power element hex.

**SETTING ADJUSTMENT:** The external range screw adjusts the operation point(s) of the control by changing the amount of spring pressure opposing the bellows. This adjustment can be for either rising or falling pressure (temperature). Differentials (open to close of the snap switch) are not adjustable on the standard switch. See Form 400 DA for differential pressure or ambient pressure compensated models.

To adjust the range of the 400 control, turn the external slotted adjustment screw clockwise to increase the pressure or temperature setting, counter-clockwise to decrease the setting.

**SEQUENCE ADJUSTMENT:** Controls with more than one snap switch will have the highest setting on the back switch and the lowest setting on the front switch if they are not simultaneous. Adjustments to the back switch are via the range screw only. The other switches are adjusted relative to the back switch by adjusting the length of their actuating screws.

Setting repeatability is approximately one percent of the standard bellows pressure range and must be interpolated for temperature switches depending on settings and range.

**AMBIENT TEMPERATURE:** The maximum ambient is 185°F (85°C). Ambient temperature compensation (cross ambient) is available for temperature switches.

**ELECTRICAL CONNECTIONS:** A terminal board is standard on single stage controls. Multi-stage controls are furnished with lead wires. Pin connectors and junction boxes are available options.

**PRESSURE CONTROLS:** Pressure controls may be installed directly at the point where the pressure is to be controlled, or mounted remotely and connected with standard pipe and fittings. The maximum media temperature is 300°F (149°C).

**TEMPERATURE CONTROLS, DIRECT CONNECTION, MODELS H-1, H-2:** Install H-1 with bulb pointing down and H-2 with bulb in horizontal position. Bulb must be in a free circulation of the medium to be controlled.

**TEMPERATURE CONTROLS, REMOTE CONNECTION, MODELS L & N:** Controls are furnished with flexible tubing (10 ft. is standard) between the control and the thermal bulb. This permits mounting the control on a wall or any other convenient support.

Model L (solid) thermal bulb must be installed within 75 degrees of vertical pointing downward (with flexible tube coming out of upper end of bulb). Model N (large coil) bulb must be installed within 75 degrees of vertical upward (with flexible tube coming out of lower end of bulb). See the mounting positions shown on back. Special bulbs are available for other mounting needs.

NON-INDUCTIVE RATINGS - STANDARD		
ELECTRICAL RATING - AMPERES		
VOLTAGE	A.C.	D.C.
115	15	0.5
230	12	0.25
440	8	----

MOTOR DUTY RATING - STANDARD		
ELECTRICAL RATING - AMPERES		
VOLTAGE	RUNNING	LOCKED ROTOR
	A.C.	A.C.
115	2.0	12.0
230	1.0	6.0
440	0.5	3.0

NON-INDUCTIVE RATINGS - OPTIONAL		
ELECTRICAL RATING - AMPERES		
VOLTAGE	A.C.	D.C.
115	20	0.5
230	15	0.25
440	10	----

NON-STANDARD DIFFERENTIALS

MOTOR DUTY RATING - OPTIONAL		
ELECTRICAL RATING - AMPERES		
VOLTAGE	RUNNING	LOCKED ROTOR
	A.C.	A.C.
115	8.0	48.0
230	4.0	24.0
440	2.0	12.0

NON-STANDARD DIFFERENTIALS

# Pressure Switches

PRESSURE CONTROL RANGES AND DIFFERENTIALS							
STANDARD RANGES VAC. IN INCHES MERCURY PRESS. IN P.S.I.G. (a)	MODEL	MAX. PRESS. P.S.I.G.	APPROX. NON-ADJUSTABLE DIFFERENTIAL P.S.I.G. (b)			BELLWS DIAMETER	MAX. SEQUENCE P.S.I.G. (c)
			STANDARD	NON-STANDARD	NON-STANDARD		
30" VAC TO 10" VAC	C-3	20	0.2	0.4	1.0	3	3
30" VAC TO 20 P.S.I.G.	A-1	80	0.5	1.0	5.0	1 1/8	8
30" VAC TO 60 P.S.I.G.	A-4	160	0.8	1.6	6.0	1 1/8	12
20" VAC TO 100 P.S.I.G.	B-3	216	2.0	4.0	16.0	3/4	24
20" VAC TO 250 P.S.I.G.	A-7	400	3.0	8.0	28.0	7/16	40
3" VAC TO 3 P.S.I.G.	C-2	10	0.06	0.2	0.4	4 1/4	2
6" VAC TO 8 P.S.I.G.	C-5	20	0.2	0.4	1.0	3	3
0.1 TO 4 1/2 P.S.I.G.	* C-1	10	0.06	0.2	0.4	4 1/4	2
0.1 TO 8 P.S.I.G.	* C-4	20	0.2	0.4	1.0	3	3
3 TO 50 P.S.I.G.	* B-1	80	0.5	1.0	5.0	1 1/8	7
5 TO 80 P.S.I.G.	* B-4	160	0.8	1.6	6.0	1 1/8	12
10 TO 200 P.S.I.G.	B-6	216	1.6	3.2	16.0	3/4	36
20 TO 1300 P.S.I.G.	A-16	2360	16.0	32.0	160.0	1/4	200
25 TO 350 P.S.I.G.	* B-7	400	3.0	8.0	28.0	7/16	40
60 TO 600 P.S.I.G.	* B-12	900	6.0	12.0	36.0	5/16	60
100 TO 1800 P.S.I.G.	* B-16	2360	16.0	32.0	160.0	1/4	200

- (a) ADDITIONAL RANGES AVAILABLE ON REQUEST.
- (b) DIFFERENTIALS WILL VARY WITH NON-STANDARD SNAP SWITCHES. DIFFERENTIALS GIVEN ON APPLICATION.
- (c) MAX SEQUENCE IS THE TOTAL SPREAD BETWEEN ACTUATION POINTS FOR MULTI-SWITCH CONTROLS.
- \* INDICATES STANDARD BELLWS RANGE FOR THE BELLWS DIAMETER.

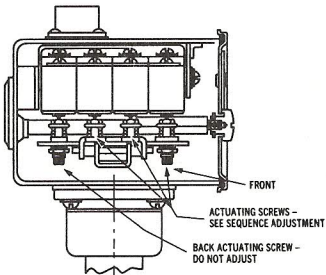

# Sensing Element and Switch Dimensions

Available in one (1) through four (4) stages

# Temperature Switches

TEMPERATURE CONTROL RANGES AND DIFFERENTIALS							
RANGE F°	MAX. TEMP. F°	APPROX. NON-ADJUSTABLE DIFFERENTIAL -F° (b)				BULB STYLE	
		STANDARD		NON-STANDARD		REMOTE	DIRECT
		HIGH END	LOW END	HIGH END	LOW END		
-30 TO +22	---	5	1.5	6	14	L. N.	H-1 H-2
-10 TO +60	---	5	1.5	6	14	L. N.	H-1 H-2
25 TO 90	120	5	1.5	6	14	L. N.	H-1 H-2
70 TO 140	167	5	1.5	6	14	L. N.	H-1 H-2
90 TO 165	195	5	1.5	6	14	L. N.	H-1 H-2
140 TO 215	245	5	1.5	6	14	L. N.	H-1 H-2
185 TO 250	276	5	1.5	6	14	L. N.	H-1 H-2
220 TO 290	317	5	1.5	6	14	L. N.	---
255 TO 330	355	5	1.5	6	14	L. N.	---
300 TO 400	437	7	1.5	8	18	L. N.	---
375 TO 480	500	10	2.0	8	18	L. N.	---
400 TO 580	625	ON APPLICATION				L. N.	---

- (a) ADDITIONAL RANGES AVAILABLE ON REQUEST.
- (b) DIFFERENTIALS WILL VARY WITH NON-STANDARD SNAP SWITCHES. DIFFERENTIALS GIVEN ON APPLICATION.
- (c) SEQUENCE CAPABILITIES GIVEN ON APPLICATION.

Temperature switches with standard bellows will have differential characteristics at the high end of the range similar to those of a B-1 pressure switch (1°F = 1 PSI). Temperature differentials with non-standard bellows often compare with a B-6 pressure switch. As a general rule, differentials at the low end of a temperature range are two and one half (2-1/2) times greater than at the high end of the range.

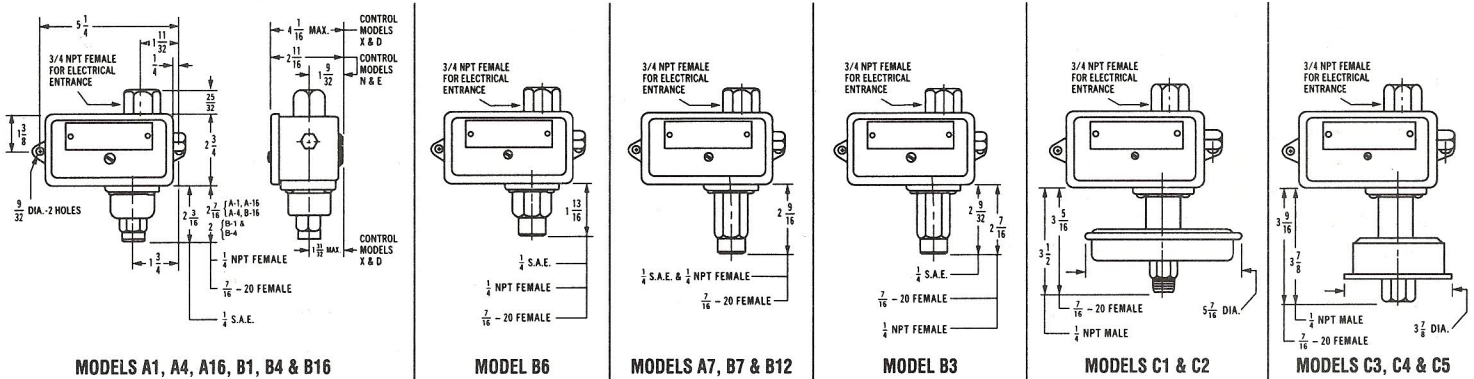

REMOTE

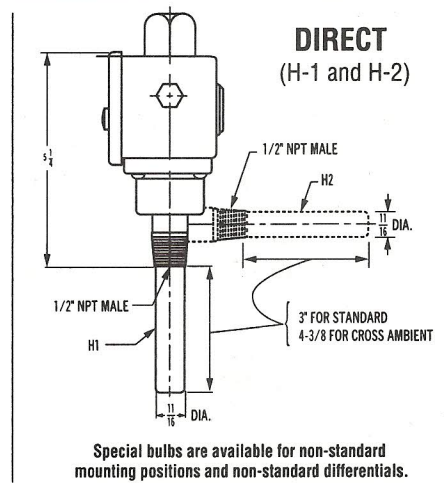
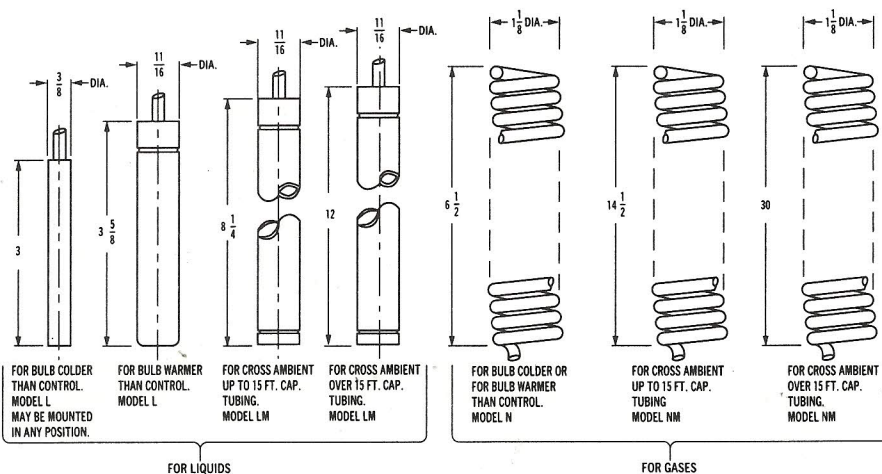

DETROIT SWITCH, INC. • 1025-33 Beaver Ave., Pittsburgh, Pa. 15233-2397

Phone (412) 322-9144 • Fax (412) 321-1997