

National Transportation Safety Board

Office of Railroad, Pipeline and Hazardous Materials

Washington, DC 20594



RRD23FR012

IIC FACTUAL REPORT

CSX Transportation Employee Fatality During Switching Operations
June 26, 2023

Table of Contents

A.	ACCIDENT.....	5
B.	INVESTIGATIVE GROUP	5
C.	ACCIDENT SUMMARY.....	6
D.	DETAILS OF THE INVESTIGATION	6
1.0	DESCRIPTION OF CSX OPERATIONS AT SEAGIRT INTERMODAL FACILITY.....	6
2.0	EVENTS PRIOR TO THE ACCIDENT	7
3.0	THE ACCIDENT.....	9
3.1	Accident Timeline	10
4.0	POST ACCIDENT INSPECTION.....	11
5.0	TRACK AND INFRASTRUCTURE INFORMATION.....	12
5.1	Accident site track description.....	12
5.2	FRA Track inspections.....	13
6.0	ACCIDENT TRAIN AND EQUIPMENT INFORMATION.....	14
6.1	Locomotive and consist information.....	14
6.2	FRA Mechanical inspections.....	15
6.3	Accident car description (DTTX 475890).....	16
6.4	Post accident inspection safety appliance inspections the accident car....	16
6.5	Post accident static reenactment of crew positions prior to the accident..	17
6.6	Locomotive digital recordings.....	18
6.7	Lead locomotive event recorder (EVR).....	18
6.8	Lead locomotive outward Video.....	19
7.0	TRAIN CONTROL, SIGNALS, AND RECORDED COMMUNICATIONS.....	19
7.1	Radio recordings.....	19
8.0	SEAGIRT FACILITY SECURITY CAMERA VIDEO.....	20
9.0	CREW OPERATIONAL INFORMATION.....	21
9.1	Crew training and certification information.....	21
9.2	Crew Hours of service (HOS) information.....	21
9.3	Crew operational testing data.....	21
10.0	MEDICAL AND PATHOLOGICAL INFORMATION.....	22
10.1	Toxicology report	22

11.0	PERSONNEL INFORMATION - ACCIDENT CONDUCTOR TRAINEE.....	22
11.1	Cell Phone Usage	22
12.0	POST ACCIDENT INTERVIEWS.....	22
12.1	Post accident interviews conducted on June 29, 2023.	22
12.2	Post accident interviews conducted on July 10th, 2023.	22
13.0	OPERATIONAL CONDITIONS.....	23
13.1	CSX Operating rules in effect at the time of the accident.	23
13.2	Method of Operation	23
13.3	CSX Operating Rules relating to the accident.	23
13.3.1	2101 - Mounting, Dismounting, and Crossing Over Equipment	23
13.3.2	CSX RULE 2102 - Riding Equipment.	24
13.3.3	CSX Rule: 2102.2 When riding on equipment, employees must not: ..	24
13.4	CSX Special instructions in effect at time of the accident.....	25
13.5	CSX Post accident actions	25
13.6	CSX Conductor Training program.....	26
13.6.1	CSX Phase I conductor training prior to the accident.....	26
13.6.2	CSX Phase II conductor training prior to the accident.....	27
13.6.3	Post accident CSX conductor training program.....	28
14.0	INTERNAL OVERSIGHT.....	28
14.1	CSX Operational Testing Program.	28
14.2	Testing records	29
15.0	EXTERNAL OVERSIGHT.	30
15.1	The Federal Railroad Administration.	30
15.2	FRA Safety alerts and bulletins.....	30
15.2.1	Safety Bulletin 2023-04 (Issued July 6, 2023).....	31
15.3	Federal regulations relating to the accident.....	31
15.3.1	Part 213–Track safety standards.....	31
15.3.2	Part 217–Railroad operating rules.	31
15.3.3	Part 218- Railroad operating practices.	31
15.3.4	Part 231- Railroad safety appliance standards.....	32
15.3.5	Part 242- Qualification and certification of conductors.....	32

15.3.6 Part 271- Risk reduction program. 32

IIC FACTUAL REPORT
CSXT Employee Fatality During Switching Operations

A. ACCIDENT

NTSB Accident No: RRD23FR012
NTSB Keys number: 192464
Accident Type: Employee Fatality
Location: Baltimore, Maryland
Date of accident: June 26, 2023
Time of accident: 8:06 pm¹
Carrier: CSX Transportation
Train type/Designation: CSX Y231(Yard crew designation)
Fatalities: 1
Injuries: 0

B. INVESTIGATIVE GROUP

NTSB	Richard Skolnekovich Rail Accident Investigator Washington, DC
NTSB	Zach Zaga Rail Accident Investigator Washington, DC
Federal Railroad Administration	Jordan Gibson FRA, Operations Specialist FRA District 2
CSX Transportation	Matthew R Meadows Director Operating Rules Jacksonville, FL
BLET	Shawn Lawton Investigator Buffalo, NY
SMART	Jared Cassity Investigator Ironton, OH

¹ All times in this report are reported as Eastern Daylight Time (EDT).

IIC FACTUAL REPORT
CSXT Employee Fatality During Switching Operations

C. ACCIDENT SUMMARY

On June 26, 2023, about 8:06 p.m. local time, a CSX Transportation (CSX) conductor trainee on CSX yard job Y231 was killed while riding the lead railcar during a shoving movement at Seagirt Marine Terminal in Baltimore, Maryland.² The conductor trainee fell from an intermodal railcar during the movement and was struck by the train³.

Visibility conditions at the time of the accident were daylight and clear; the weather was 84°F with intermittent rain showers earlier that day.

The crew of yard job Y231 consisted of an engineer in the locomotive cab, a conductor, and the conductor trainee. The train was composed of 2 locomotives and 15 empty intermodal railcars. Seagirt Marine Terminal surveillance camera data reviewed by National Transportation Safety Board (NTSB) investigators showed that the crew was in the process of shoving the railcars around a curve, with the conductor and conductor trainee protecting the shoving movement.⁴ The conductor was on the west side of the lead railcar (the right side in the direction of travel). The conductor trainee was controlling the shoving movement from the east side of the lead railcar (the left side in the direction of travel) with one foot on the second step of the railcar and one foot on the platform.⁵ The conductor trainee communicated instructions using his handheld radio that they needed to stop within 5 railcar lengths.⁶ As the train slowed, the conductor trainee fell from his position and was struck by the train.

D. DETAILS OF THE INVESTIGATION

1.0 Description of CSX Operations at Seagirt Intermodal facility.

Seagirt Marine Terminal is a 284-acre dedicated container terminal that handles 97 percent of container volume at the Port Baltimore. Seagirt is operated by Ports America Chesapeake and is serviced by CSX Transportation at its adjacent rail intermodal facility.

² A shoving movement is the process of pushing railcars or a train from the rear with a locomotive.

³ An intermodal railcar is designed to carry shipping containers used in intermodal freight transportation. The intermodal railcars in this accident were each made up of three to five connected single-unit railcars; all railcars in the accident train were empty.

⁴ A crew member protects a shoving movement by visually determining that the route is clear of obstructions and conflicting movements.

⁵ A crew member controls a shoving movement by giving instructions to the engineer.

⁶ Crews commonly use railcar lengths to communicate distances.

IIC FACTUAL REPORT

CSXT Employee Fatality During Switching Operations

The intermodal rail tracks located within the Seagirt port facility contain a large concrete pad that is used to load or unload intermodal containers (shipping containers) for either tractor trailer or rail transport. The facility contains nine (9) intermodal tracks which are owned by the state of Maryland and are used by CSX for the placement of shipping containers from or onto CSX intermodal railcars.

Seagirt intermodal tracks are connected to interchange tracks located at Penn Mary yard which is located just to the north of the Seagirt intermodal facility. The Seagirt Intermodal facility and Penn Mary facilities are separated by industry tracks that run perpendicular to both yards. These facilities are separated by a non-signaled rail diamond with a stop sign. Canton railroad, which is also owned by the State of Maryland, operates the interchange facility at Penn Mary Yard. The timetable direction of the intermodal tracks at Seagirt terminal is east to west with the west end of the tracks connecting to the rail diamond located to the south (cardinal direction) of Penn Mary yard.

Seagirt Marine Terminal in Baltimore is managed by Ports of America. The track is inspected by Canton Railroad and CSX operates their Intermodal trains in and out with local and road crews. Track maintenance is performed by Cranemasters⁷ through service requests made by Ports of America.

2.0 Events prior to the Accident

The CSX Y231 is yard switching assignment at Seagirt Terminal with occasional local work between Canton Rail yard and CSX Bayview yard. This is a regular assignment with a crew consisting of an engineer and conductor. Switching operations at Seagirt terminal are directed by the Bayview yardmaster in coordination with the Ports of America ramp manager.

Work instructions and documentation from the Bayview yardmaster are delivered to the crews primarily through a fax machine located in the crew room. Verbal instructions from the yardmaster are given via a phone located in the crew room or by crew radios.

On June 26, 2023, the crew of Y231 reported for duty at the crew room in Seagirt terminal. A conductor trainee was assigned to this crew several days prior as part of his training requirements in the CSX conductor qualification and training program.

The crew stated in interviews that they signed up at 3:59 pm. After receiving their instructions and switch list from the yard master at Bayview yard they held their job briefing where they discussed the work to be performed. This work consisted of

⁷ Cranemasters is a railroad contractor specializing in railway maintenance and services.

IIC FACTUAL REPORT
CSXT Employee Fatality During Switching Operations

shifting out a series of cars into three separate blocks between various tracks with the leading car in the consist scheduled to go to the Bayview yard. The crew also discussed the portable derails and blue flags that had been placed on multiple tracks by the rail contractor Cranemasters while they were performing rail tie replacement work in Seagirt Terminal.

After completing their job briefing, the crew walked to track 5 to inspect and board their equipment. On inspecting the locomotives, the accident engineer contacted the yard master requesting a mechanical service truck to inspect a brake shoe on the lead locomotive. The engineer stated in his interview that a mechanical employee inspected the locomotive brake shoe and that he took no exceptions. Afterwards the engineer stated that he conducted a standing locomotive brake test and took no exceptions to the locomotive brakes.

The crew then waited onboard the locomotive per the yardmaster's instruction for the outbound CSX I137 train to depart Seagirt terminal and for the track workers to remove the blue flags and portable derails on track 5. Once the outbound CSX train I137 departed and the Cranemaster workers had cleared the tracks, the crew cut the last block of cars off on track 5 before proceeding with the remainder of the cars to 7 track.

During this initial movement, the engineer stated in his interview that he conducted a running release⁸ of the brakes and found no exceptions with the braking performance of his consist.

On 7 track, they cut off and left the middle block of cars before proceeding back to 5 track to couple up to the cars that remained. They then took the cars on 5 track over to 1 track where they began spotting the cars for the "splits". Afterwards, they then moved and coupled up to the cars in 2 track.

At this point, the conductor stated in his interview that the company contracted van had not arrived, so they determined that they would have to ride the cars while shoving to the final spot on 5 track.

They contacted the yardmaster to request permission to pass the Norfolk Southern Diamond⁹ and then mounted the second car from the locomotives. The train then proceeded north towards the diamond while the conductor and trainee rode the cars to the last switch that would route them to 5 track. Once the locomotive stopped at the diamond, the conductor and trainee dismounted. The trainee then

⁸ A running release is the release of an automatic brake service application while the train is still in motion.

⁹ A diamond is a railroad track structure used where one track crosses another track at grade.

IIC FACTUAL REPORT
CSXT Employee Fatality During Switching Operations

directed the movement north at restricted speed¹⁰ by giving the engineer car counts over the radio until all the cars had cleared the switch. After the train had cleared the switch, the trainee reversed the switch in order to line their train for the return movement back to 5 track.

At this point, the conductor and trainee observed the van arriving in the parking area to pick them up. The conductor stated that they discussed the vans arrival and after a brief discussion, decided to change their plan of riding the shove of cars to the end of the track, and would instead ride the cars only to the vehicle crossing. Once the car they were riding was completely across the vehicle crossing, their plan was to stop the train movement, dismount the car that they had been riding, and then take the van to the end of the track where they would direct the trains movement from a position on the ground.

After this discussion, the conductor then mounted the western side of the accident car (DTTX 475890), while the trainee mounted the eastern side. Neither the conductor nor trainee remained on the bottom rung of the ladder that is situated on both sides of the car. The conductor rode with both feet on the first horizontal bar above the rung, while the trainee stood with his left foot on the horizontal bar, and his right foot on the platform that crosses the leading end of the car.

The conductor stated in his interview that they did not ride the bottom rung as it was considered a violation of CSX operating rules when riding cars across a grade crossing. He also stated that due to the amount vehicular traffic at Seagirt, that he felt it was a safer method to ride in the event of a vehicle collision while they were riding the car.

Once they had both climbed up onto the cars, the trainee began the shoving movement by telling the engineer on the radio "Clear lined, rear." This was followed by the instruction to begin shoving east with a car count of "ten cars."

3.0 The Accident

Event recorder data indicated that train Y231 began shoving into track 5 at approximately 8:04 pm (Figure 1). The conductor stated during his interview that the trainee was controlling the movement via his portable radio on his left hip, with a lapel microphone attached to his vest on his right shoulder. He stated that his switch list was in pocket.

The conductor stated that the trainee was issuing clear car counts of "ten cars" to the engineer as they proceeded timetable east, and continued these counts until

¹⁰ Restricted Speed: is a speed that will permit stopping within one-half the range of vision. It will also permit stopping short of a train, a car, an obstruction, on-track equipment, or a stop signal.

IIC FACTUAL REPORT CSXT Employee Fatality During Switching Operations

they began to approach the vehicle crossing. As they approached the crossing the conductor stated that the trainee gave the engineer a count of five cars. As the engineer began slowing the movement in response to this count, the conductor stated that he felt some slack¹¹ run out of the cars, and then saw the trainee lose his balance and fall forward into the gauge of the track.

The conductor stated that he immediately got on his radio and yelled “stop” multiple times before jumping down from the car and moving to a position in front of the car where he could operate the brake pipe angle cock¹² and initiate a train line emergency¹³ to stop the movement.

After the trainee fell into the gauge, the equipment continued to move for another 34 feet as the slack ran out of the train and before the conductor could initiate a train line emergency. During this time, the trainee became pinned at the mid-section of his torso between the eastern leading wheel of the car and the rail, sustaining fatal injuries (figure1).



Figure 1. Accident overview illustration.

3.1 Accident Timeline

Based on information gained from crew interviews and event recorder data, the Operations Group developed the following timeline of events preceding the accident (Table 1).

¹¹ Slack or slack action is the amount of free movement of one railcar before it transmits its motion to an adjoining coupled railcar.

¹² A brake pipe angle cock is valve located at each end of locomotives or railcars and is used to open or close the brake pipe.

¹³ A train line emergency occurs when the air pressure contained within the air brake system is fully released resulting in the complete application of the train brakes

IIC FACTUAL REPORT
CSXT Employee Fatality During Switching Operations

Start Time	End Time	Timetable Direction	Distance traveled in feet	Forward movement	Reverse movement	Track	Remarks
6:50 PM	7:02 PM	West	3015	3015		5	Initial movement 5 to 7 Track
7:02 PM	7:07 PM	East	2386		2386	7	Shove into 7 Track
7:07 PM	7:07 PM	West	11	11		7	7 Track switch work
7:09 PM	7:09 PM	East	2		2	7	7 Track switch work
7:09 PM	7:11 PM	West	872	872		7	Movement from 7 to 5 Track
7:12 PM	7:13 PM	East	569		569	5	Shove on 5 Track
7:13 PM	7:14 PM	West	14	14		5	5 Track switch work
7:14 PM	7:14 PM	East	13		13	5	5 Track switch work
7:15 PM	7:19 PM	West	2035	2035		5	Movement from 5 to 1 Track
7:19 PM	7:23 PM	East	1732		1732	1	Shove on 1 Track
7:23 PM	7:28 PM	West	1500	1500		1	Movement from 1 to 2 Track
7:28 PM	7:32 PM	East	2562		2562	2	Shove on 2 Track
7:32 PM	7:50 PM	West	591	591		2	2 Track switch work
7:51 PM	7:54 PM	East	1342		1342	2	2 Track switch work
7:57 PM	8:04 PM	West	4286	4286		2-5	Movement from 2 to 5 Track
8:04 PM	8:06 PM	East	614		614	5	Shove on 5 Track (Accident)

Table 1. Accident timeline of events.

4.0 Post Accident inspection.

On arrival, NTSB investigators, FRA and CSX officials conducted accident site inspections to begin collecting information and evidence required for the NTSB investigation. The purpose of the accident site inspections was to collect and document information related to the accident. This site walk included the following activities:

- Accident site inspection and photography.
- Accident distance measurements.
- FRA post-accident track inspections.
- FRA post-accident mechanical inspections.
- Static railcar re-enactments of employee positioning on the riding appliances.
- Partial re-enactment of the fatal shoving movement made by the crew of Y231.
- Video recordings of the shoving re-enactment.

IIC FACTUAL REPORT
CSXT Employee Fatality During Switching Operations

5.0 Track and infrastructure information.

5.1 Accident site track description.

The Seagirt Terminal consists of a series of nine ladder tracks that are utilized to for the classification and storage of intermodal railcars (Figure 2). These tracks run in a cardinal west to east direction with the west section referred to as the Penn Mary End while the east section is referred as the Dundalk end. The ladder tracks are divided by 8 hand thrown switches on the Penn Mary end, and by 7 hand thrown switches on the Dundalk end of the terminal.

On the Penn Mary end, tracks 1 through tracks 4 have unmarked areas for vehicles and equipment to cross the tracks. These crossings are known to CSX crews as the "splits" and this term appears in the Baltimore terminal division timetable. The CSX track map detailing the Seagirt terminal¹⁴ that was submitted to investigators identify the areas to the north and south of this crossing as "above split" and "below split" in relation to this unmarked crossing.

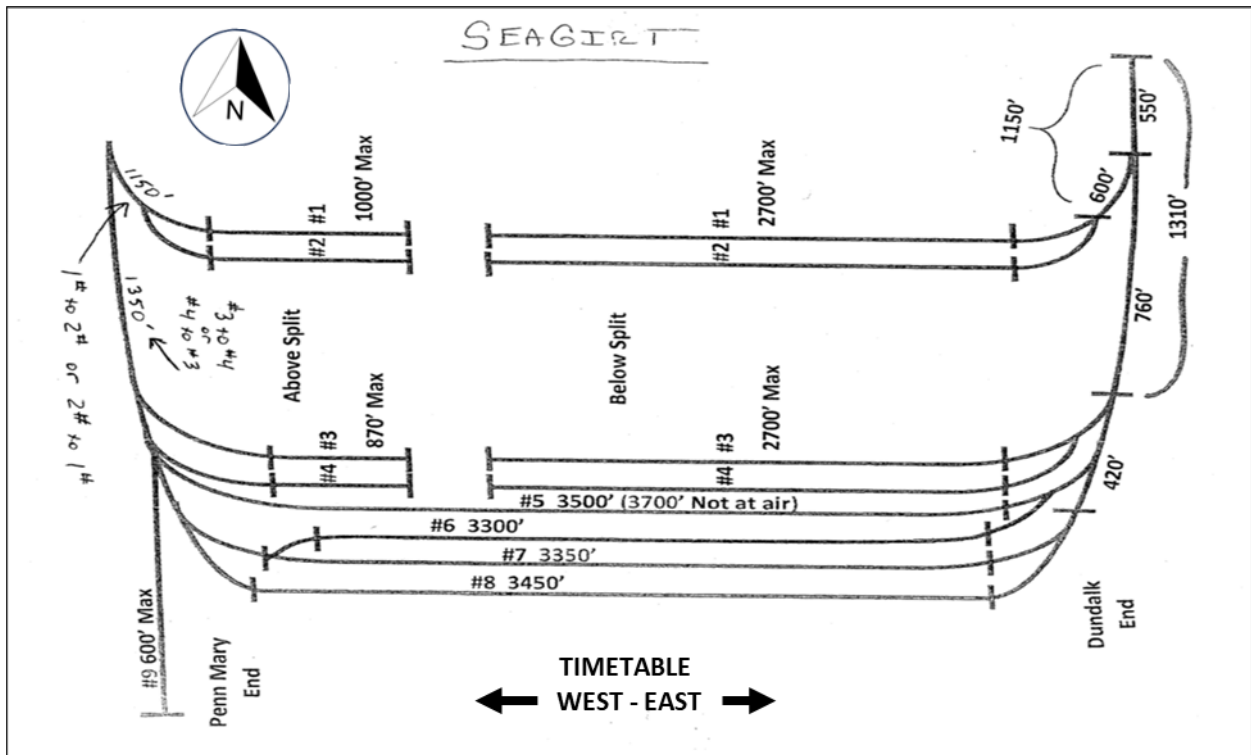

Figure 2. Seagirt terminal track map.

¹⁴ The Seagirt track map is located in the docket at the following web address:
<https://data.ntsb.gov/Docket/?NTSBNumber=RRD23FR012>

IIC FACTUAL REPORT

CSXT Employee Fatality During Switching Operations

On the western most portion of the Penn Mary end, tracks 3, tracks 5 and track 8 have a privately marked crossing for vehicles and equipment to cross (Figure 3). This private crossing was installed by the Ports of America and is equipped with manual gates, standard flashing light signals¹⁵ and railroad crossing signage (Highway-Rail Grade Crossing¹⁶). This crossing is not equipped with any type of train detection circuit and is activated manually by Ports of America employees who activate this crossing when they view train movements approaching the crossing through security camera's mounted on poles overlooking this crossing.



Figure 3. Seagirt vehicle crossing.

5.2 FRA Track inspections.

The accident occurred on track 5 on the Penn Mary (west) side of Seagirt terminal. This segment of track is designated as an FRA Class 1 track with a maximum operating speed of 10 mph.

FRA track inspectors performed a post-accident walking inspection of the tracks preceding the final movement of Y231 and made the following determinations:

1. The accident occurred in the return curve approximately 20-feet 9-inches west of the highway-rail grade crossing.
2. Track grade was level and consisted of a right-hand return curve for a number eight turnout.
3. Geometry measurements were taken at 15-feet 6-inches increments for 15 stations leading up to the accident scene.

¹⁵ A standard flashing-light signal consists of two red lights in a horizontal line flashing alternately at approaching highway traffic.

¹⁶ The Highway-Rail Grade Crossing (R15-1) sign is commonly identified as a Crossbuck Sign and is reflectorized white with the words "RAILROAD CROSSING" in black lettering.

IIC FACTUAL REPORT
CSXT Employee Fatality During Switching Operations

4. The tracks consisted of 115RE jointed rail, and every other crosstie was box anchored, excluding the ties in the turnout, which were fully box anchored.
5. The turnout was approximately 100-feet west of the highway-rail grade crossing and then continued west in a tangent for approximately 107-feet before another number eight turnout.
6. The track consisted of 115RE jointed rail, and every other crosstie was box anchored, except the ties in the turnout, which were fully box anchored. The crosstie plates were 13-inch double-shoulder plates with conventional 6-inch cut spikes. The plates consisted of one rail-holding spike on the field side and one rail-holding spike on the gage side to secure track gage.
7. The crossties were in good shape with nominal evidence of loose spikes, lateral plate movement, or plate cutting. The turnout components were 115RE and in good shape. The turnout ties, with various lengths to support the turnout, were also in good shape. The ballast was not fouled from the highway-rail grade crossing to the first turnout.

FRA's post-accident inspection of the track determined that all track geometry measurements complied with Part 213 Track Safety Standards for the Class of track.

6.0 Accident train and equipment information

6.1 Locomotive and consist information.

At the time of the incident the train consisted of two locomotives and 15 empty intermodal railcars. Locomotive CSXT 328 was the controlling locomotive and was facing north. Locomotive CSXT 4551 was in trail of leading locomotive and was facing south. The total train length was 2,579 feet (Table 2).

IIC FACTUAL REPORT
CSXT Employee Fatality During Switching Operations

Position in consist	Identifier	Cars	Length in feet	Equipment type	Remarks
1	CSX328	-	74	GE AC4400CW	Controlling - Facing north
2	CSX4551	-	74	EMD SD70MAC	Trailing - Facing south
3	DTTX730523	1	205	Intermodal Flatcar	Single car
4	FEC73019	1	76	Intermodal Flatcar	Single car
5	DTTX470354	1	77	Intermodal Flatcar	Single car
6	DTTX723553	3	204	Intermodal Flatcar	Articulated
7	DTTX724490	3	204	Intermodal Flatcar	Articulated
8	DTTX470297	1	77	Intermodal Flatcar	Single car
9	DTTX767934	3	205	Intermodal Flatcar	Articulated
10	DTTX680871	1	77	Intermodal Flatcar	Single car
11	DTTX890544	3	204	Intermodal Flatcar	Articulated
12	TTAX654364	5	291	Intermodal Flatcar	Articulated
13	TTAX553770	5	291	Intermodal Flatcar	Articulated
14	TTAX55028	5	291	Intermodal Flatcar	Articulated
15	TTAX753080	5	291	Intermodal Flatcar	Articulated
16	TTRX360021	3	189	Intermodal Flatcar	Articulated
17	DTTX475890	1	77	Intermodal Flatcar	Single car (Accident car)
Total train Length equals 2,907 feet.					

Table 2. Y231 Locomotive and consist information

6.2 FRA Mechanical inspections.

FRA mechanical inspectors performed a post-accident inspection of locomotive CSXT 328. The locomotive was found to be current on all required tests and inspections, with no exceptions identified. Following this, inspectors performed an emergency application from the rear brake pipe of the last car (DTTX 475890) to determine if the Pneumatic Control Switch (PCS)¹⁷ was functioning properly on the locomotive. There were no exceptions taken during this inspection.

FRA mechanical inspectors performed a post-accident Inspection of the accident car, DTTX intermodal car (475890) and its riding appliances. There were no defects identified. Inspectors then performed a post-accident inspection on the remainder of accident cars within the consist. There were with no exceptions noted during this inspection.

FRA mechanical inspectors requested railroad records pertaining to all of the equipment involved in the accident. This included the following:

¹⁷ Pneumatic Control Switch PCS - An air-operated switch, activated by an emergency or penalty brake application, which drops the engine speed to idle.

IIC FACTUAL REPORT
CSXT Employee Fatality During Switching Operations

- (1) Copies of both locomotive blue cards (F8180.49A).
- (2) Daily locomotive inspection reports.
- (3) Maintenance records and single car air test date for DTTX 475890
- (4) Single car air test date for entire consist.

FRA mechanical inspectors found the requested documents in compliance with federal standards with no exceptions taken.

6.3 Accident car description (DTTX 475890)

The accident car was a 77-foot intermodal car built on September 9, 1997, by Gunderson manufacturing based in Portland Oregon. The DTTX mark identifies the car type as an all-purpose double-stack railcar. A double stack railcar is a type of railroad car specially designed to carry intermodal containers (shipping containers) used in intermodal freight transport. DTTX cars of this type can be configured either as a single car or can be combined into a series of cars with the use of articulated connectors. The use of articulated connectors is designed to help reduce slack action and improve the ride quality for the cargo. Key specifications of this car are listed in table 3.

Key Specifications for DTTX 475890	
Length, inside	53'-1 3/8"
Length, over couplers	76'-9 1/4"
Clearance	AAR Plate H
Width, inside	8'-9 3/16"
Width, extreme	9'-11 15/16"
Light weight	55,000 lbs.
Load limit	165,000 lbs.
Gross rail load	220,000 lbs.
Type	AAR S615

Table 3. DTTX 475890 specifications.

6.4 Post accident inspection safety appliance inspections the accident car.

On June 27, 2023, investigators inspected the safety appliances of the accident car (DTTX 475890). Figure 3 with a descriptive table details the measurements of the various safety appliances measured.

IIC FACTUAL REPORT
 CSXT Employee Fatality During Switching Operations

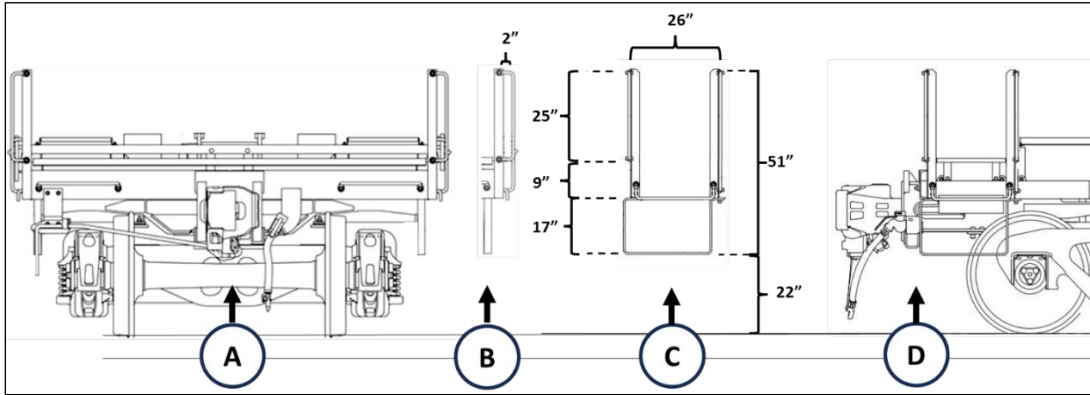

Figure 3. Schematic drawing of the DTTX 475890 intermodal car.

Symbol	Figure 1 descriptions.
A	Schematic drawing of the leading end of the intermodal car.
B	Schematic drawing with measurement of the width of the handrail as seen from the leading end of the car (A).
C	Schematic drawing with measurements detailing the widths and heights of the various safety appliance as seen from the side of the car (D).
D	Schematic drawing of the side portion of the leading end of the intermodal car.

Figure 3 Table. Description table of the figure 3 schematic drawing.

6.5 Post accident static reenactment of crew positions prior to the accident.

Investigators performed a static reenactment on the accident car utilizing the methods that the conductor and conductor trainee used to ride the car before the fatal accident. The positions utilized by the conductor and trainee were derived from the security camera footage obtained by NTSB investigators.

The purpose of this reenactment was to observe the level of stability on the railcar that the conductor and trainee could have reasonably had in relationship to the location of the fixed safety appliances. The photographs in figure 4 document this reenactment:



Figure 4. Investigator re-enactment on accident car.

IIC FACTUAL REPORT
CSXT Employee Fatality During Switching Operations

6.6 Locomotive digital recordings.

Digital evidence received by CSX included the locomotive outward facing videos and event recorder information from CSXT 328.

6.7 Lead locomotive event recorder (EVR).

The operations working group conducted a review of the event recorder data from the lead locomotive CSX328. The locomotive wheel size was measured at 42 inches. The following timeline was developed based on the group’s observations (Table 4):

Time from-to		Feet	Dir Call	Speed mph	Throttle	BP psi	BC psi	REMARKS
20:04:22	20:04:53	0	For	0	Idle	90	70	No movement
20:04:53	20:04:53	0	Rev	0	Idle	90	70	Reverser set to reverse
20:04:53	20:05:03	0	Rev	0	T1	90	70	Releases Independent Brake and begins to apply throttle to begin the movement
		0	Rev	0	T2	90	52	
		0	Rev	0	T2	90	30	
		0	Rev	0	T2	90	12	
		0	Rev	0	T3	90	10	
		1	Rev	0	T3	90	11	
20:05:03	20:05:14	70	Rev	4	T2	84	0	Reduction in throttle and applies Minimum Brake Application
20:05:15	20:05:24	78	Rev	4	T2	83	2	No change in throttle position or brake pipe. Engineer utilizes Independent to control speed.
		86	Rev	5	T2	84	8	
		94	Rev	5	T2	84	4	
		102	Rev	5	T2	84	4	
		109	Rev	5	T2	84	1	
		117	Rev	5	T2	84	1	
		126	Rev	5	T2	84	1	
		134	Rev	5	T2	84	1	
		142	Rev	5	T2	84	1	
		150	Rev	5	T2	84	1	
159	Rev	5	T2	84	0			

Table 4. CSXT 328 event recorder data with event timeline notes.

IIC FACTUAL REPORT
CSXT Employee Fatality During Switching Operations

Time from-to	Feet	Dir Call	Speed mph	Throttle	BP psi	BC psi	REMARKS	
* Begin one second per data row	20:06:07	518	Rev	7	Idle	84	0	Throttle to idle
	20:06:08	556	Rev	5	Idle	84	8	Independent Brake applied in graduated steps.
	20:06:09	564	Rev	5	Idle	84	28	
	20:06:10	570	Rev	4	Idle	84	50	
	20:06:11	576	Rev	4	Idle	84	60	
	20:06:12	581	Rev	3	Idle	84	53	Estimated time Trainee began to fall
	20:06:13	586	Rev	2	T1	84	27	Throttle applied while Independent is gradually released.
	20:06:14	589	Rev	2	T1	84	11	
	20:06:15	592	Rev	1	T2	84	9	
	20:06:16	595	Rev	2	T2	84	10	Highlighted area is suspected strike time.
* One second per data row	20:06:17	599	Rev	2	T2	84	5	Throttle applied while Independent is gradually released.
	20:06:18	602	Rev	1	T2	84	3	
	20:06:19	604	Rev	1	T2	84	1	
	20:06:20	607	Rev	1	T2	84	1	Throttle to idle
	20:06:21	610	Rev	1	Idle	84	0	Emergency application of train line
	20:06:22	613	Rev	1	Idle	84	1	
	20:06:23	614	For	1	Idle	84	15	Locomotive speed is 0 as emergency application is complete
	20:06:24	615	For	0	Idle	84	37	
	20:06:25	615	For	0	Idle	84	54	
	20:06:26	615	For	0	Idle	44	58	
20:06:27	615	For	0	Idle	7	64		

Table 4. CSX328 event recorder data with event timeline notes.

6.8 Lead locomotive outward Video.

See recorders specialist factual report.

7.0 Train control, signals, and recorded communications.

7.1 Radio recordings.

NTSB investigators requested all radio recordings associated with the Y231 crew during the day of the accident. CSX managers on scene stated that the radio system they used provided only real time audio and that the system did not have the ability to provide any post-accident recordings for review.

IIC FACTUAL REPORT
CSXT Employee Fatality During Switching Operations

8.0 Seagirt facility security camera video.

A review of the Seagirt Terminal surveillance camera data that contained video footage of the accident. The following timeline was developed based on the investigator’s observations (Table 5):

TIME	FRAME	DESCRIPTION
8:06:05	1	Security camera video start time
8:06:12	1	Slack action is observed. Both Conductor and trainee’s positions observed moving forward in the direction of the movement.
8:06:13	1	Trainee is observed facing the direction of movement and bending over the leading grab iron.
8:06:13	2	The trainee’s right foot is observed leaving the railcar platform towards the front of the railcar. The trainee’s left foot is observed remaining in the railcar ladder steps.
8:06:13	2	The trainee’s right foot is observed in contact with the ground, outside of the east side gauge of track 5, while his left foot has left the ladder and is on the railcar platform. The trainee is observed facing away from the coupler and in front of the railcar.
8:06:13	4	The trainees right foot remains in contact with the ground, outside of the east side gauge of track 5, while his left foot remains on the railcar platform. The trainee's body position in now observed to be perpendicular to the track and facing away from the coupler in front of the railcar.
8:06:13	5-6	The trainees right foot remains in contact with the ground, outside of the east side gauge of track 5, while his left foot remains on the railcar platform. The trainee's body position remains perpendicular to the track and rolling toward the direction of movement.
8:06:13	7	The trainee's upper torso is within the gauge of the track and is perpendicular to the railcar. His left leg is upright and has fully left the platform.
8:06:13	8	The trainee's upper torso is within the gauge of the track and perpendicular to the railcar. His left leg is upright and has fully left the platform.
8:06:14	1-8	The trainee is oriented face down with his upper torso within the gauge. As the trainee completes the fall, his lower torso and legs are observed to lay across the east side rail of track 5.
8:06:14	9	The leading east side wheel of the intermodal railcar is observed striking the trainee's mid-section and pinning him against the rail. The trainee remains pinned in this manner for the remainder of the movement (08:06:14 to 08:06:26).
8:06:17	1	The Conductor begins climbing down the ladder on the west side of the intermodal car.

Table 5. Seagirt Security camera timeline.

IIC FACTUAL REPORT
CSXT Employee Fatality During Switching Operations

TIME	FRAME	DESCRIPTION
8:06:21	1	The Conductor moves in front of the intermodal car and places his hands on the coupler as he is forced backwards by the slack action of the car.
8:06:22	1	The conductor moves to the east side of the coupler and appears to reach for the angle cock with his right hand. Slack action continues to force him backwards with the direction of movement.

Table 5. Seagirt Security camera timeline (continued).

9.0 Crew operational information.

9.1 Crew training and certification information.

NAME	HIRE DATE	CRAFT	ENGINE SVC	LAST CERTIFICATION	LAST RULES EXAM
Accident engineer	06/22/1998	engineer	05/18/2000	12/31/2020	10/22/2022
Accident conductor	9/30/2013	conductor	N/A	12/31/2022	05/11/2023
Accident conductor trainee	4/3/2023	conductor trainee	N/A	N/A	04/27/2023

Table 6. Crew training and certification information.

9.2 Crew Hours of service (HOS) information.

NAME	DATE	TOTAL HOURS ON DUTY	PRIOR OFF-DUTY TIME	OFF-DUTY LOCATION
Accident engineer	06/26/2023	6:02	16:30	BAM 3
Accident conductor	06/26/2023	8:09	16:13	BAM 3
Accident conductor trainee	06/26/2023	6:01	16:12	BAM 3

Table 7. Crew Hours of service (HOS) information.

9.3 Crew operational testing data.

NAME	FROM DATE	END DATE	TOTAL TESTS	Non-Compliant	Non-compliant percentage
Accident engineer	7/18/22	7/2/23	21	4	19.05%
Accident conductor	1/22/23	5/21/23	5	2	40%
Accident conductor trainee	6/21/23	6/21/23	1	0	0%

Table 8. Crew operational testing data.

IIC FACTUAL REPORT
CSXT Employee Fatality During Switching Operations

10.0 Medical and Pathological information.

10.1 Toxicology report

Post-accident, specimens obtained from the conductor trainee by the Office of the Chief Medical Examiner (ME) of the State of Maryland were provided for testing by the Civil Aerospace Medical Institute (CAMI) of the Office of Aerospace Medicine, of the Federal Aviation Administration. The specimens were tested and found to be negative for the presence of illicit drugs and alcohol. No other CSX employees were tested.

11.0 Personnel Information - Accident conductor trainee.

11.1 Cell Phone Usage

Security camera footage obtained by investigators revealed no evidence to indicate that the conductor or conductor trainee were utilizing cell phones or other portable electronic device during the accident. During post-accident inspection of the conductor trainee's equipment, CSXT managers found the conductor trainees cell phone stowed away within his personal equipment bag.

12.0 Post accident Interviews.

12.1 Post accident interviews conducted on June 29, 2023.

The investigative team conducted four interviews on scene relating to this accident. These interviews were held at the CSX Transportation building in Baltimore, Maryland on Thursday, June 29, 2023, and were conducted in the following order:

Yard job Y231 Engineer (accident train).
Yard Job Y231 Conductor (accident train).
CSX Conductor Mentor (Trainer).
CSX Bayview Yardmaster.

Please refer to the docket for the full interview's transcripts.¹⁸

12.2 Post accident interviews conducted on July 10th, 2023.

The Operations working group conducted three Teams interviews relating to this accident. These interviews were held on Monday, July 10, 2023, and were conducted in the following order:

¹⁸ The complete interview transcripts are located in the docket at the following web address:
<https://data.nts.gov/Docket/?NTSBNumber=RRD23FR012>

IIC FACTUAL REPORT
CSXT Employee Fatality During Switching Operations

CSX Manager of Train operations, Baltimore Division.
CSX Manager of Training Programs.
CSX new hire conductor.

Please refer to the docket for the full interview's transcripts.¹⁹

13.0 Operational conditions

13.1 CSX Operating rules in effect at the time of the accident.

- CSX Employee Operating Manual effective February 1, 2023.
- CSX Air Brake & Train Handling, effective June 1, 2023.
- CSX Equipment Handling, effective June 1, 2023.
- CSX Safe Way, effective June 1, 2023.
- Baltimore Terminal Subdivision Timetable No.1, effective September 1, 2017, updated through May 25, 2023.

13.2 Method of Operation

The Y231 was operating under CSX rules that governed movement on other than main track during its movements throughout Seagirt terminal as designated by CSX operating rules.

Such movements are made at restricted speed which is a speed that permits stopping within one-half the range of vision, short of a train, a car, on-track equipment, an obstruction, a Stop signal, a derail, or an improperly lined switch and must not exceed 10 MPH when not moving to or from the main track, operating through hand operated switches unless specified otherwise in special instructions.

13.3 CSX Operating Rules relating to the accident.

13.3.1 2101 - Mounting, Dismounting, and Crossing Over Equipment

2101.1 When mounting, dismounting, or crossing over equipment, employees must:

1. Use locomotive steps and car side ladders;
2. Scan the area and equipment for hazards;
3. Mount and dismount clear of switches, derails, bridge approaches, close clearances, or any object that could cause a slip, trip, or fall;

¹⁹ The complete interview transcripts are located in the docket at the following web address:
<https://data.nts.gov/Docket/?NTSBNumber=RRD23FR012>

IIC FACTUAL REPORT
CSXT Employee Fatality During Switching Operations

4. Face the equipment;
5. Maintain three points of contact;
6. Place the defined heel of the boot against the ladder rungs and brace feet against the side rails;
7. Keep clear of adjacent tracks; and
8. Stop at the bottom step or ladder rung to check for solid footing before dismounting.

13.3.2 CSX RULE 2102 - Riding Equipment.

When riding on equipment, employees must:

1. Position body to face the equipment and look in the direction of travel
2. Maintain 3-points of contact, keeping secure hand holds and footing,
3. Be prepared for unexpected movements and slack action at all times,
4. Ride the side of cars equipped with a horizontal grab iron at least 12 inches above the floor of the car or at least one vertical grab iron that allow an employee to stand upright.
5. Ride the side of rail cars or the trailing end of a cut of cars equipped with an end platform.
6. Ride the steps or front/rear locomotive platforms when positioned on the outside of a moving locomotive,
7. Dismount before passing a close clearance sign or reaching a close clearance,
8. Ride on the side of equipment away from live tracks, main tracks, sidings, close clearances, or other hazards, and
9. Dismount equipment prior to coupling.

13.3.3 CSX Rule: 2102.2 When riding on equipment, employees must not:

- a. Place hands, arms, or legs inside equipment with shiftable loads or near the end gates of a drop end gondola; or
- b. Occupy side locomotive walkways when:
 1. Traversing over crossings (railroad or vehicle), curves, bridges, and control points; and
 2. Above 20 mph; or

IIC FACTUAL REPORT
CSXT Employee Fatality During Switching Operations

- c. Use bridge plates or container brackets as hand holds on flat cars; or
- d. Transition from one side of a car to the other while the car is moving, except in an emergency situation, or
- e. Ride: a. Platform between coupled cars, or
- b. End of cars being shoved unless the car is equipped with a riding platform that has a solid safety rail positioned between the employee and the end of the equipment, or
- c. Couplers, draw-heads, cut levers, or cushion underframe devices, or
- d. Bottom step of equipment when traversing highway-rail crossings at grade, or
- e. The middle ladder of tank cars, or
- f. The side of equipment that is adjacent to a main track or siding that is occupied with equipment, or g. The following series of cars: LEWX (1000-1099), LEWX (2100-2197), DEAX (11351-11450), CIGX (802713-803211), or
- h. Equipment other than the front steps of a locomotive when traversing from the top of a hump into the bowl tracks, or
- i. Locomotive platforms behind the walkway chains.

13.4 CSX Special instructions in effect at time of the accident.

Special instructions relating to this accident can be found in the Baltimore terminal subdivision timetable no.1, effective September 1, 2017²⁰.

13.5 CSX Post accident actions

On June 27, 2023, CSX issued a safety alert to its employees regarding the accident at Seagirt Terminal in Baltimore, Maryland²¹.

²⁰ Special instructions provide additional operational information or instructions in timetables.

A copy of this instruction can be found in the accident docket at the following web address: <https://data.ntsb.gov/Docket/?NTSBNumber=RRD23FR012>

²¹ A copy of the June 27, 2023, alert can be found in the accident docket at the following web address: <https://data.ntsb.gov/Docket/?NTSBNumber=RRD23FR012>

IIC FACTUAL REPORT
CSXT Employee Fatality During Switching Operations

This alert contained rule reminders that restated CSX rules 104.5, 2102.1 through 2102.3 and provided illustrations on various methods to ride certain types of rail cars. It also illustrated a non-compliant method for riding an intermodal car.

13.6 CSX Conductor Training program.

In February 2012, the Federal Railroad Administration (FRA) issued new regulations prescribing the minimum Federal safety standards for the eligibility, training, testing, certification of conductors. This regulation was listed under 49 CFR Section 242 and required Class I railroads to submit a conductor training program that met federal requirements to the FRA for approval.

In 2015, CSX railroad submitted a training program that was approved by the FRA in accordance with 49 CFR Section 242.119. In that submission, CSX submitted training documents on how it would train new hire employees not previously certified as conductors. These employees, also known as conductor trainee's, are trained in two separate phases of training.

CSX Phase I training is held in Atlanta Georgia and is conducted with a mixture of classroom and field training to prepare conductor trainee's for follow on field training.

CSX Phase II conductor training consists of on-the-job (OJT) training in the conductor trainee's seniority district²² and applies the training that they were given in Phase I with additional training given by local managers and previously certified conductors on the assigned territory.

Conductor trainees are required to successfully complete Phase I and Phase II of the conductor training program before receiving a conductor certification.

13.6.1 CSX Phase I conductor training prior to the accident.

CSX Phase I training is a 4-week training program that consists of both classroom and field instruction conducted by instructors at the CSX Railroad Education and Development Institute (REDI) training facility in Atlanta, Georgia. The classroom instruction includes multimedia presentations, classroom props, mockups, training simulators and periodic computer-based training exercises. Classroom training topics include basic railroad operating rules, signal aspects and rules governing train movement.

²² Seniority districts are geographical locations established through collective bargaining agreements within companies that have unionized labor organizations.

IIC FACTUAL REPORT CSXT Employee Fatality During Switching Operations

Field instruction is conducted on site with the use of railroad mockups that provide simulated training of various railroad activities such as changing couplers²³, lacing air hoses²⁴, and mounting or dismounting rail cars.

In addition, CSX maintains several locomotives and railcars at the REDI center that are used to provide instruction to conductor trainees in the practical application of techniques for mounting, riding, or dismounting several types of rail cars during train movement.

Conductor trainees are tested and evaluated in the Phase I training based on their knowledge and demonstrated performance in complying with CSX railroad rules and procedures. Testing and evaluation of conductor trainee's is conducted with a mixture of classroom examinations and field evaluations.

Field examinations utilize a checklist of performance standards with a rating scale of effective or ineffective.

13.6.2 CSX Phase II conductor training prior to the accident.

CSX Phase II conductor training consists of OJT on the employee's seniority district. A transportation manager oversees the conductor trainee's OJT program. Transportation managers hold office conferences on a periodic basis with the employee as well as conducting periodic operational performance observations to evaluate the employee's performance on required tasks during the phase II training program.

Conductor trainees are scheduled for OJT assignments under the direct supervision and instruction of certified conductors. This training is conducted in all classes or types of service that the conductor trainee will be expected to perform in the territory assigned.

During CSX Phase II training, conductor trainees are required to successfully complete periodic evaluations of the required task and subtask competency lists. These evaluations are known as OJT checklists and are described by CSX as training that is conducted while performing job related tasks in the work environment. The results of these evaluations are entered into an electronic records system known as the railroad qualification system (RQS).

²³ A Couple is a device located at both ends of all rail cars in a standard location to provide a means for connecting one rail car to another.

²⁴ Lacing air hoses is the act of coupling train line air hoses together between different cars to establish brake pipe air continuity throughout a train.

IIC FACTUAL REPORT

CSXT Employee Fatality During Switching Operations

A manager reviews with the employee those tasks and subtasks that the employee did not perform correctly to ensure an understanding of the performance requirements. Employees are then required to repeat those tasks and be re-evaluated by a different manager. If the employee fails to demonstrate proficiency on the performance of the tasks/subtasks on the third attempt, the employee is not advanced in the program

Upon successful completion of Phase II and following a review of the items required by 49 CFR Section 242.109, the employee is issued a certificate as a conductor.

13.6.3 Post accident CSX conductor training program.

On July 31, 2023, CSX issued a press release²⁵ stating that it had entered into a partnership with the international Association of Sheet Metal, Air, Rail and Transportation Workers – Transportation Division (SMART-TD) to extend conductor training at the REDI center for an additional week.

CSX stated that the extra week of training would focus on performing tasks in a field setting to increase trainees' exposure to railcar switching scenarios, radio communication, securement of equipment, brake tests and other fundamentals of the conductor's role.

14.0 Internal Oversight.

14.1 CSX Operational Testing Program.

As required by federal regulation 49 CFR part 217, CSXT supervisors conduct operational testing to evaluate compliance with the current CSX Operating rules, related Timetable Special Instructions, and federal regulations.

All CSXT non-management employees, non-management employees of foreign railways and contractors working in safety sensitive positions on CSXT property and while on duty are subject to this operational testing.

Operational testing is performed by a qualified testing supervisor following procedures and instructions contained in the CSXT Operational Testing program Manual²⁶ in effect on February 1, 2022, and updated in May 2023.

²⁵ A copy of the July 31, 2023, announcement can be found in the accident docket at the following web address: <https://data.nts.gov/Docket/?NTSBNumber=RRD23FR012>

²⁶ The complete CSXT Operational Testing program Manual can be found in the docket at the following web address: <https://data.nts.gov/Docket/?NTSBNumber=RRD23FR012>

IIC FACTUAL REPORT
CSXT Employee Fatality During Switching Operations

Operational testing performed by Supervisors who are not qualified may only perform operational tests under the direct supervision of a qualified supervisor.

The length of the qualification period is dependent on the experience and progress of the supervisor's ability to perform operational tests. The Regional Directors of Safety and Operating Practices determine when a supervisor is qualified to perform operational tests.

CSX Operational testing is conducted by supervisors observing employees performing a variety of defined activities. These testing activities are designated by a test number listed in the CSX operational testing manual and contain the operating rules associated with the activity they are observing.

Testing Supervisors document the results of employee operational testing with the applicable rules listed under the individual test with either a "comply" for compliance or "fail" for non-compliance. Failure of any rule listed for that test number is a failure of that test in its entirety.

14.2 Testing records

On June 29, 2023, NTSB Investigators requested CSXT's operational testing records conducted at Seagirt or from the MP between Seagirt and Bayview yard for the year prior to this accident. On July 5, 2023, CSX provided these records in an excel spreadsheet entitled "20230705 OPTS records since 07012022 for BAK 88, BAK 89, BAM 0, BAO 8, & BAL 5.xlsx".

The records submitted contained 2,962 tests conducted over the period of July 1st, 2022 through July 4th, 2023, and included a mixture of CSX operational testing results for the, mechanical, engineering and transportation departments.

The below table details CSXT operational testing by departments for the period of July 1st, 2023, through July 4th, 2023.

Department	Total of all tests conducted	Total of tests in compliance	Total of tests not in compliance	Compliance Percentage	Non-compliant Percentage
Transportation	1829	1550	279	84.75%	15.25%
Mechanical	691	676	15	97.83%	2.17%
Engineering	442	432	10	97.74%	2.26%
Totals:	2962	2658	304		

IIC FACTUAL REPORT
CSXT Employee Fatality During Switching Operations

The below table details CSXT operational testing results of transportation employees for the period of July 1st, 2023, through July 4th, 2023.

Milepost location	Total of all tests conducted	Total of tests in Compliance	Total of tests not in compliance	Compliance Percentage	Non-compliant Percentage
BAO008	932	751	181	80.58%	19.42%
BAK088	675	603	72	89.33%	10.67%
BAM000	121	111	10	91.74%	8.26%
BAL005	88	72	16	81.82%	18.18%
BAK089	13	13	0	100.00%	0.00%
Totals:	1829	1550	279		

15.0 External oversight.

15.1 The Federal Railroad Administration.

The Federal Railroad Administration (FRA) is the primary agency for the creation and enforcement of federal railroad safety regulations. The FRA performs these functions with the purpose of standardizing railroad safety standards as a method to reduce railroad related accidents.

Rail safety regulations and statutes that govern FRA inspection and enforcement activities are documented under Title 49, Subtitle B, Chapter II of the Code of Federal Regulations (CFR)²⁷.

15.2 FRA Safety alerts and bulletins.

Safety Advisories are issued by FRA to provide guidance and clarification to railroads concerning regulatory rail safety requirements and other important safety issues.

²⁷ An electronic version of Title 49, Subtitle B, Chapter II of the CFR can be found at the following web address: <https://www.ecfr.gov/current/title-49/subtitle-B/chapter-II>

IIC FACTUAL REPORT
CSXT Employee Fatality During Switching Operations

15.2.1 Safety Bulletin 2023-04 (Issued July 6, 2023)

On July 6, 2023, the FRA issued a Safety Bulletin 2023-04²⁸ in reference to this accident. In this bulletin, the FRA encouraged all railroads to identify location-specific safety issues to cover during safety briefings and to train or retrain their employees with the intention of increasing awareness to the dangers of riding moving equipment.

The FRA also instructed Railroads to review their training programs to ensure their training programs were adequate for both the employees that oversee trainees and that the trainees were familiar with their duties, have received proper instruction, and were continuously monitored for compliance and safety.

15.3 Federal regulations relating to the accident

15.3.1 Part 213–Track safety standards.

This part prescribes minimum safety requirements for railroad track that is part of the general railroad system of transportation. In general, the requirements prescribed in this part apply to specific track conditions existing in isolation. Therefore, a combination of track conditions, none of which individually amounts to a deviation from the requirements in this part, may require remedial action to provide for safe operations over that track. This part does not restrict a railroad from adopting and enforcing additional or more stringent requirements not inconsistent with this part.

15.3.2 Part 217–Railroad operating rules.

Through the requirements of this part, the Federal Railroad Administration learns the condition of operating rules and practices with respect to trains and other rolling equipment in the railroad industry, and each railroad is required to instruct its employees in operating practices.

15.3.3 Part 218- Railroad operating practices.

This part prescribes minimum requirements for railroad operating rules and practices. Each railroad may prescribe additional or more stringent requirements in its operating rules, timetables, timetable special instructions, and other special instructions.

²⁸ The referenced FRA Safety Bulletin 2023-04 is located in the accident docket at the following web address: <https://data.nts.gov/Docket/?NTSBNumber=RRD23FR012>

IIC FACTUAL REPORT
CSXT Employee Fatality During Switching Operations

15.3.4 Part 231- Railroad safety appliance standards.

The Federal railroad safety appliance standards encompassed in part 231 serve the purpose of increasing railroad safety by identifying the applicable safety appliance requirements for various individual railcar types.

15.3.5 Part 242- Qualification and certification of conductors.

FRA regulations for certification of conductors, as required by the Rail Safety Improvement Act of 2008 went into effect on February 8, 2012, as 49 CFR part 242.

The purpose of this part is to ensure that only those persons who meet minimum Federal safety standards serve as conductors and to reduce the rate and number of accidents and incidents and to improve railroad safety. As part of that program, railroads are required to have a formal process for training prospective conductors and determining that all persons are competent before permitting them to serve as a conductor.

This part prescribes minimum Federal safety standards for the eligibility, training, testing, certification, and monitoring of all conductors to whom it applies. This part does not restrict a railroad from adopting and enforcing additional or more stringent requirements consistent with this part.

The conductor certification requirements prescribed in this part apply to any person who meets the definition of conductor contained in § 242.7, regardless of the fact that the person may have a job classification title other than that of conductor.

15.3.6 Part 271- Risk reduction program.

The purpose of this part is to improve railroad safety through structured, proactive processes and procedures developed and implemented by railroads.

Each railroad subject to this part must establish a Risk Reduction Program (RRP) that systematically evaluates railroad safety hazards on its system and manages the risks associated with those hazards to reduce the number and rates of railroad accidents/incidents, injuries, and fatalities.

Submitted by:
Richard Skolnekovich
IIC/Operations GC