

# Car Damage Report

3-12-15  
DGT-004  
Rev 4

①

Car Number TILX 731 777

Wreck index Number NA

Consist 36

Date of Derailment 1-8-77

Location BNSF Oklahoma TX  
Pinard 1987

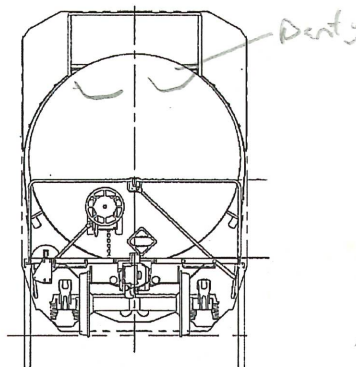
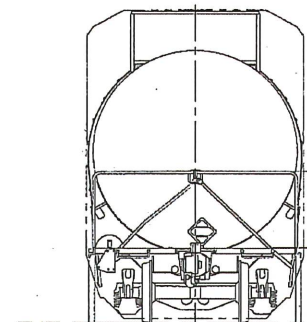
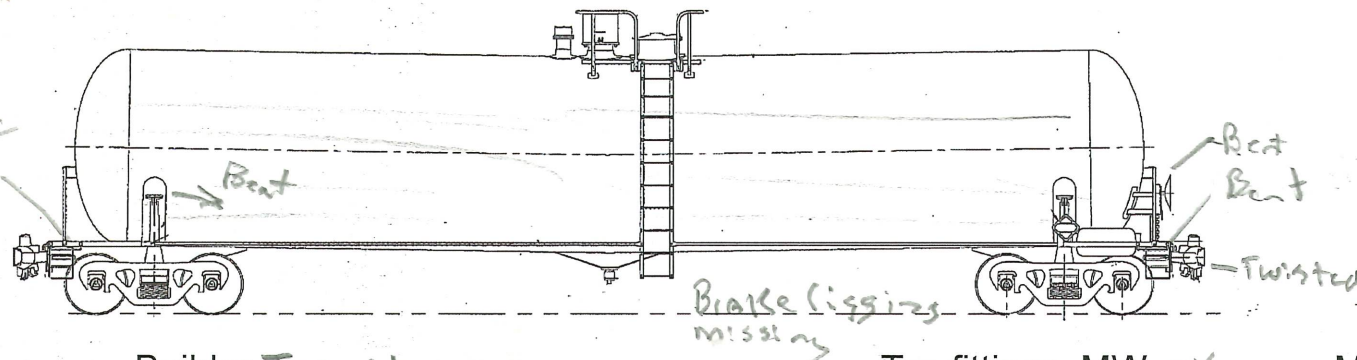
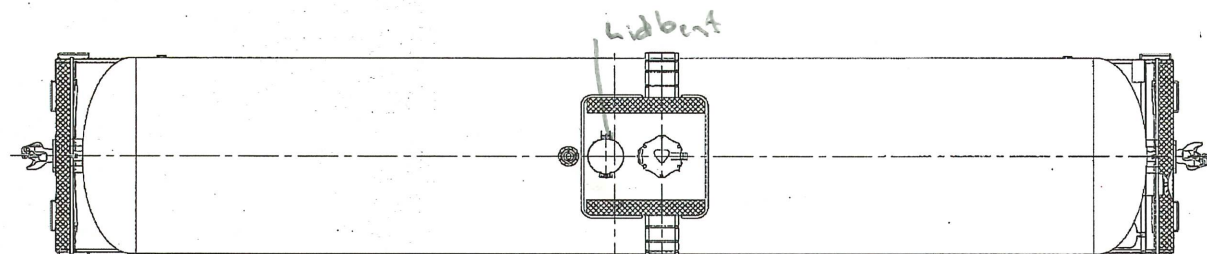
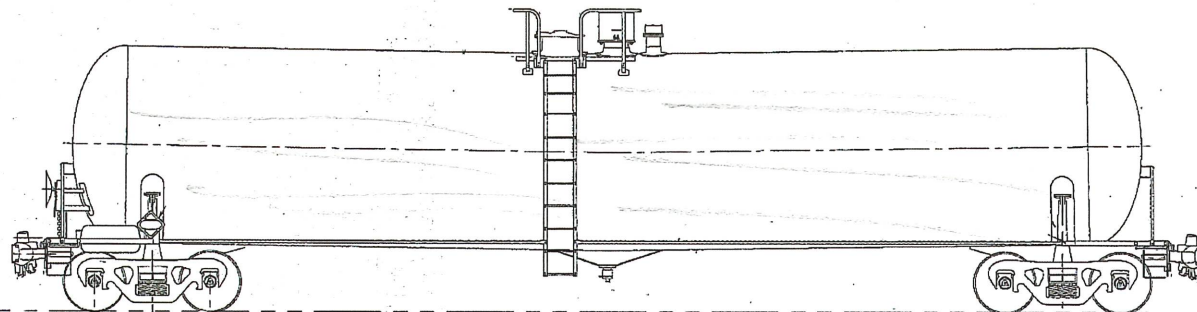

Builder Trinity

Built Date 10-30-70

DOT 117 J 100 W 30,300 gal

File# T19039

Loss of Commodity Yes / No

Valves -Leaked / Sheared No

Top fittings MW OK MH OK

Bottom Outlet Leg OK Handle DT OK

Breach- Thermal Tear No Mech Tear No

Draft Sill A Twisted B Twisted

Head Shield A OK B Bent

PRD Functioned- Yes No

Skid OK

7

# Car Damage Report

3-12-15  
DGT-004  
Rev 4

Car Number T1LX731779

Wreck index Number NA Consist 37

Date of Derailment 1-8-22

Location OKIA Union TX

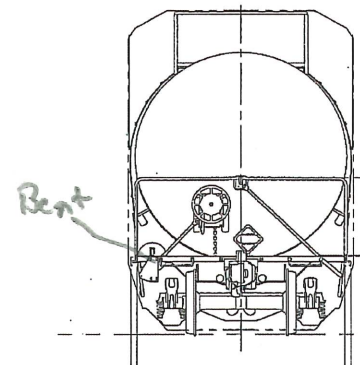
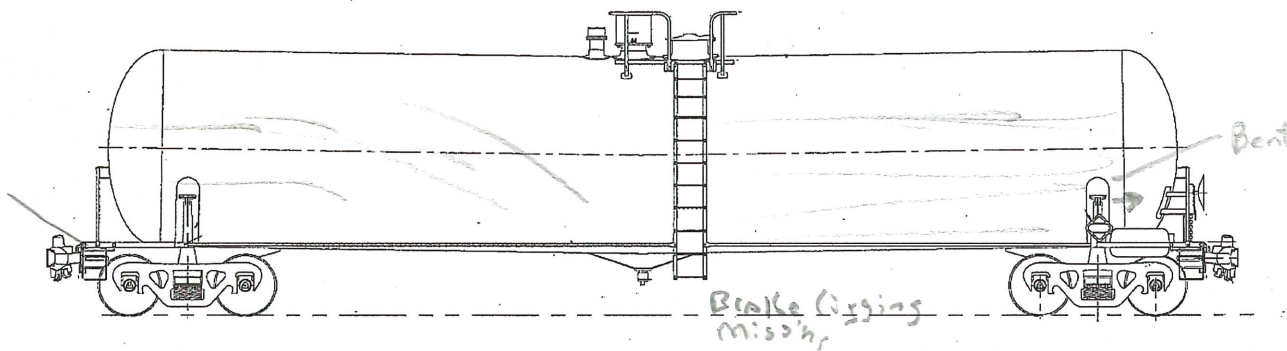
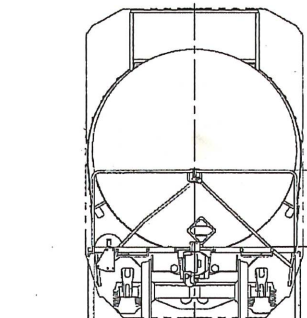
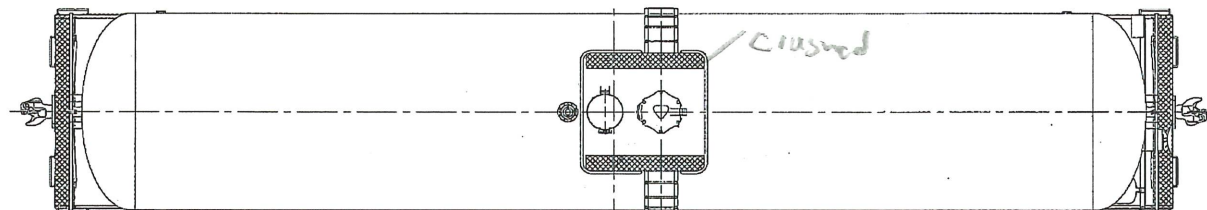
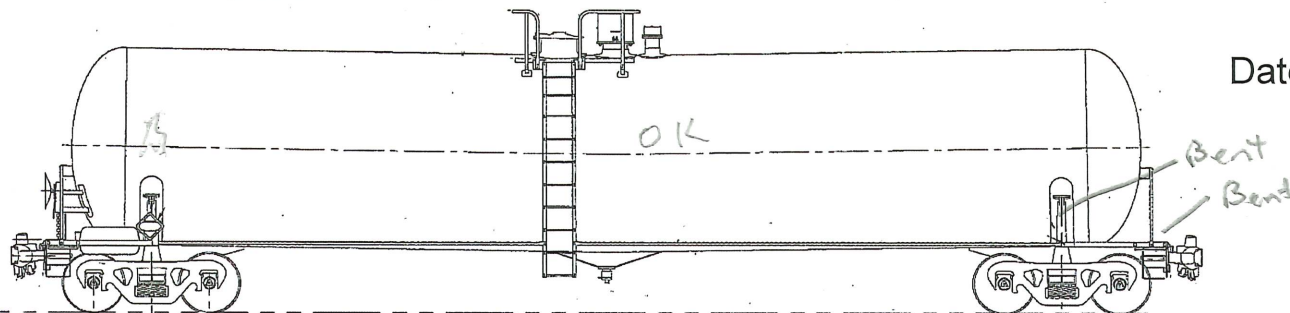

Builder Trinity  
 Built Date 10-30-20  
 DOT 117J100W  
 File# T19039  
 Loss of Commodity Yes / No  
 Valves -Leaked / Sheared No

Top fittings MW OK MH OK  
 Bottom Outlet Leg Sheared Handle DT Bent ok  
 Breach- Thermal Tear No Mech Tear No  
 Draft Sill A OK B OK A Coupler Sheared  
 Head Shield A OK B OK  
 PRD Functioned- Yes No  
 SK:d OK

# Car Damage Report

3-12-15  
DGT-004  
Rev 4

Car Number T1LX 73169Z

Wreck index Number NA Consist 38

Date of Derailment 1-8-22

Location OKIA Union Tx  
Phila 1987

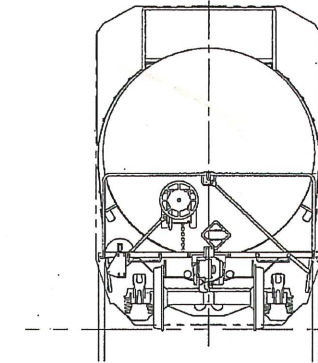
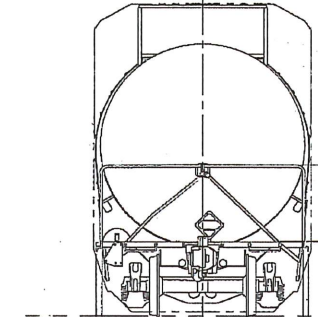
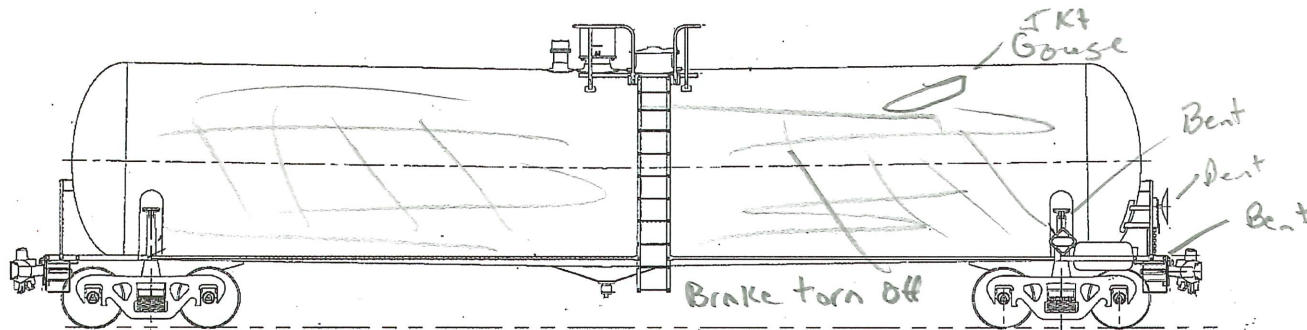
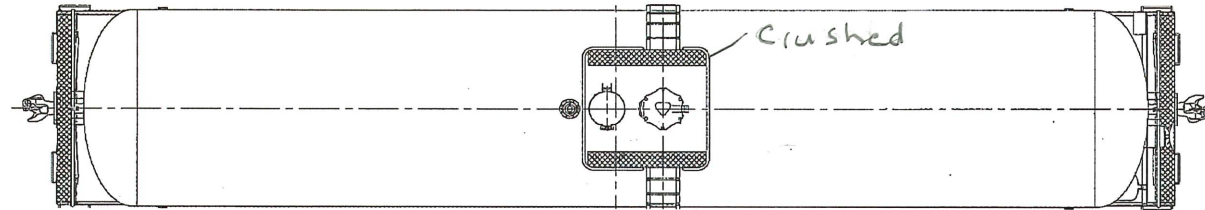
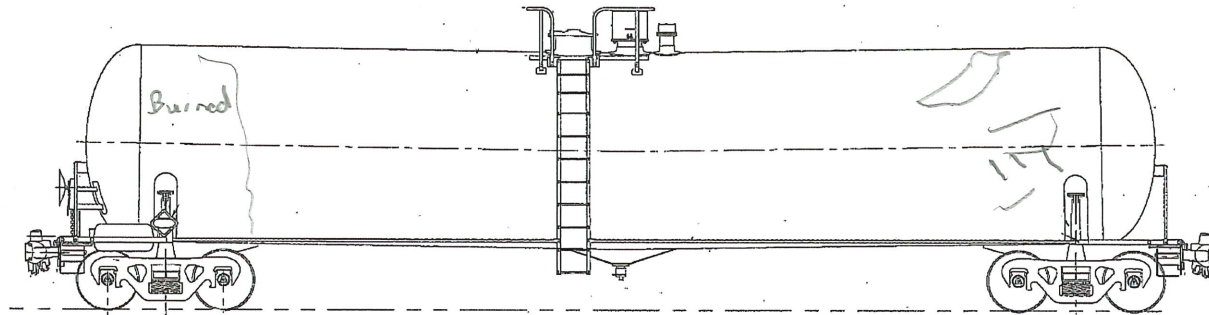

Builder Trinity  
 Built Date 10-30-20  
 DOT 1175100W  
 File# T19039  
 Loss of Commodity Yes / No  
 Valves -Leaked / Sheared

Top fittings MW OK MH OK  
 Bottom Outlet Leg Sheared Handle DT Bent  
 Breach- Thermal Tear No Mech Tear No  
 Draft Sill A OK B Twisted Left  
 Head Shield A OK B OK  
 PRD Functioned- Yes No  
 Skid OK

# Car Damage Report

3-12-15  
DGT-004  
Rev 4

Car Number T1LX731698

Wreck index Number 6

Consist 39

Date of Derailment 1-8-22

Location OKlaunion TX

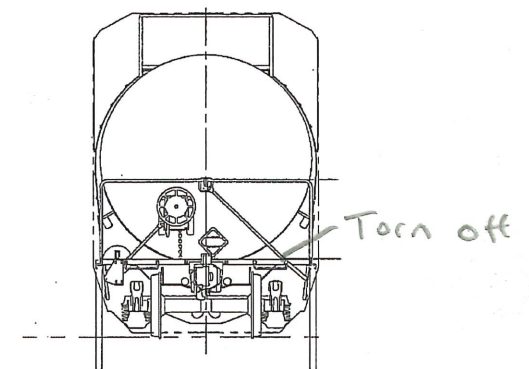
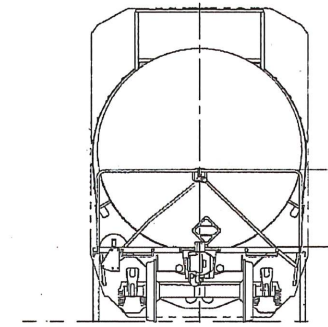
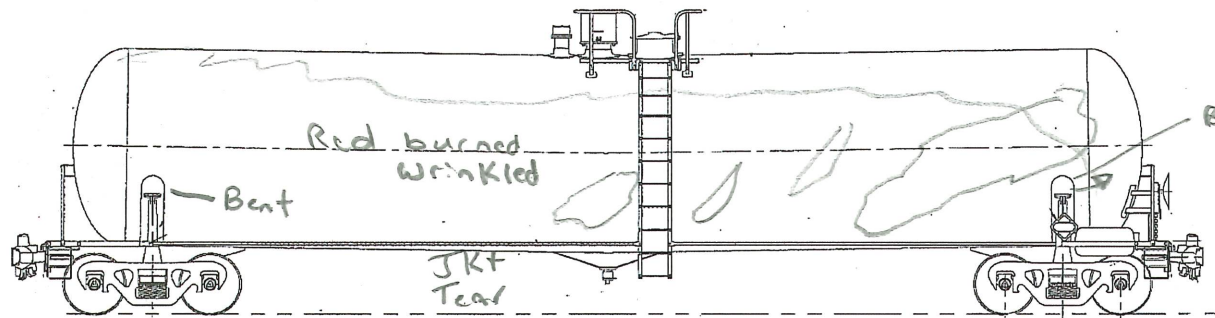
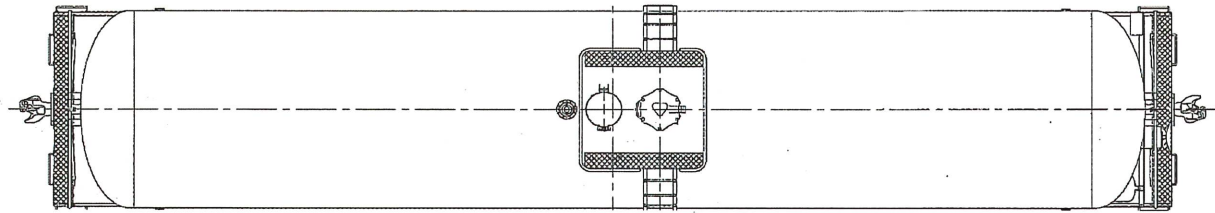
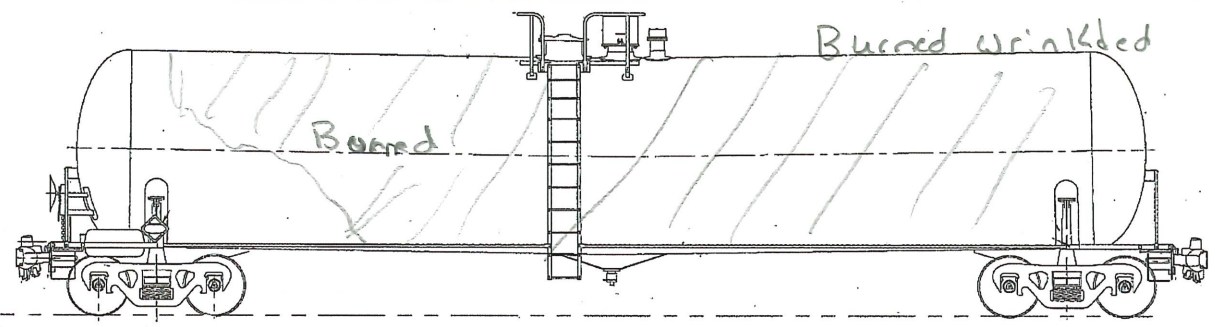

Builder Trinity  
 Built Date 10-30-20  
 DOT 117J100W  
 File# T19039  
 Loss of Commodity Yes / No  
 Valves -Leaked / Sheared No

Top fittings MW OK MH OK  
 Bottom Outlet Leg Sheared Handle DT Torn off  
 Breach- Thermal Tear No Mech Tear No  
 Draft Sill A Twisted B OK  
 Head Shield A OK B OK  
 PRD Functioned- Yes No  
 SKid OK

1/2

7

# Car Damage Report

3-12-15  
DGT-004  
Rev 4

Car Number TILX 731775

Wreck index Number 5

Consist 40

Date of Derailment 1-8-22

Location OKLA Union TX

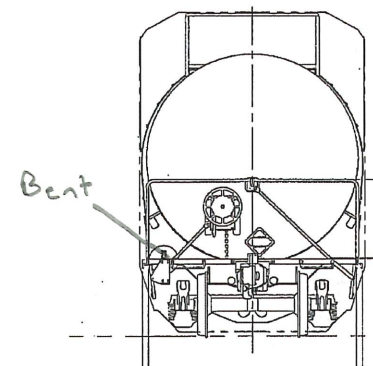
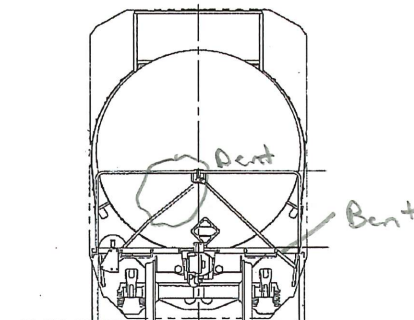
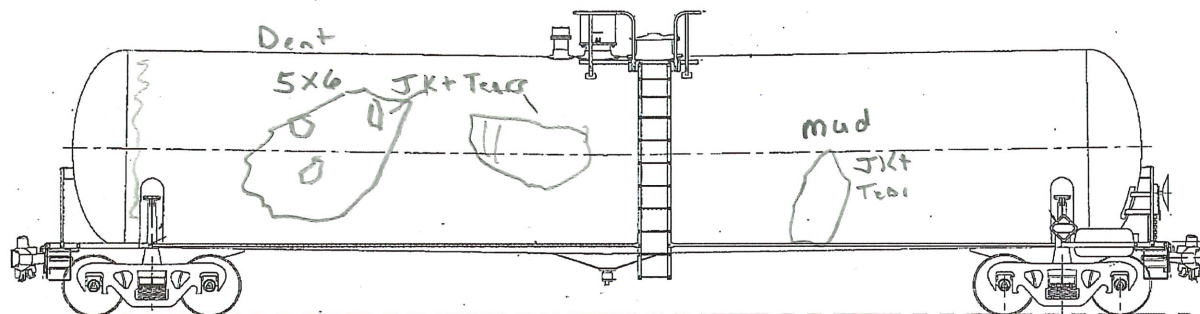
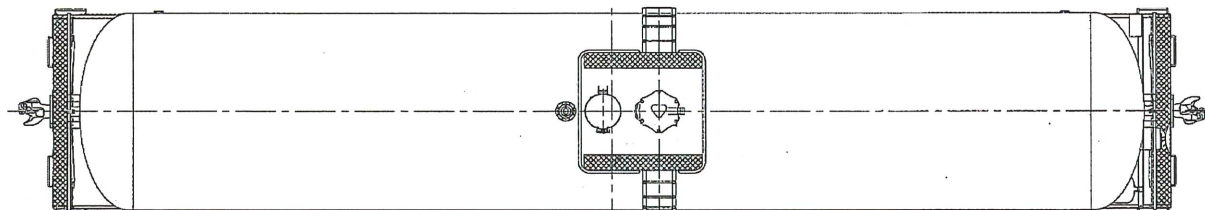
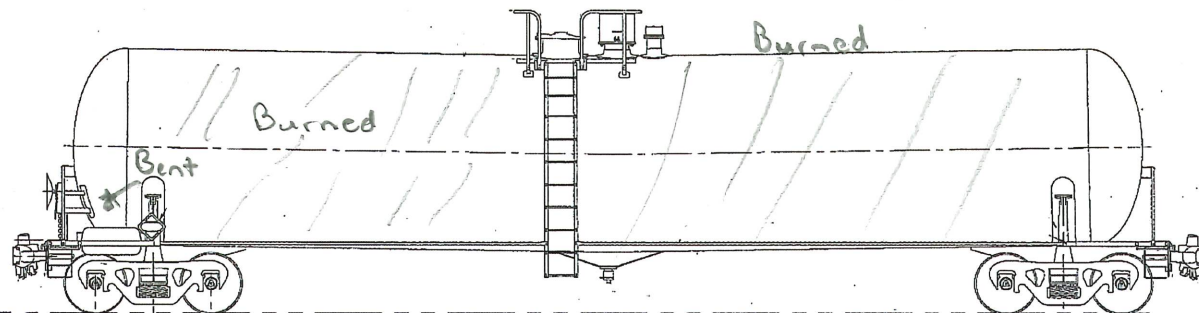

Builder Trinity  
 Built Date 10-28-70  
 DOT 117J100W  
 File# T19039  
 Loss of Commodity Yes / No  
 Valves -Leaked / Sheared No

Top fittings MW OK MH OK  
 Bottom Outlet Leg Sheared Handle DT OK  
 Breach- Thermal Tear No Mech Tear No  
 Draft Sill A OK B Twisted torn  
 Head Shield A OK B OK  
 PRD Functioned- Yes No  
 Skid OK

1/2

Coupler B A 731680

721 A End

4

# Car Damage Report

3-12-15  
DGT-004  
Rev 4

Car Number TILX 731680

Wreck index Number 1

Consist 41

Date of Derailment 1-8-22 (Hold)

Location OK Union TX

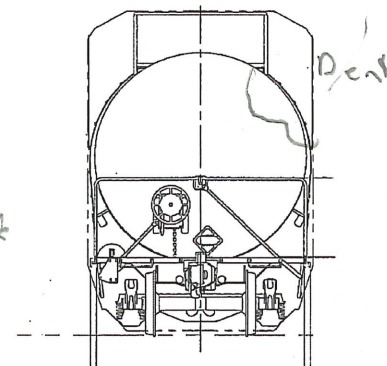
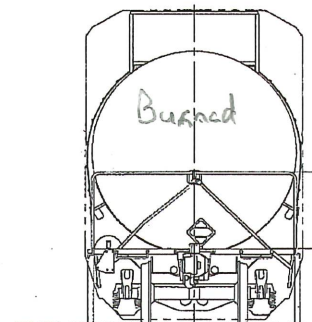
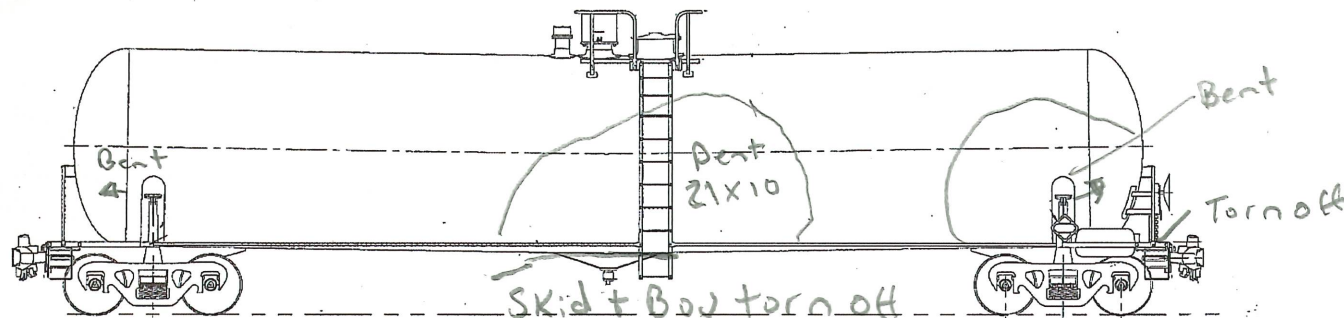
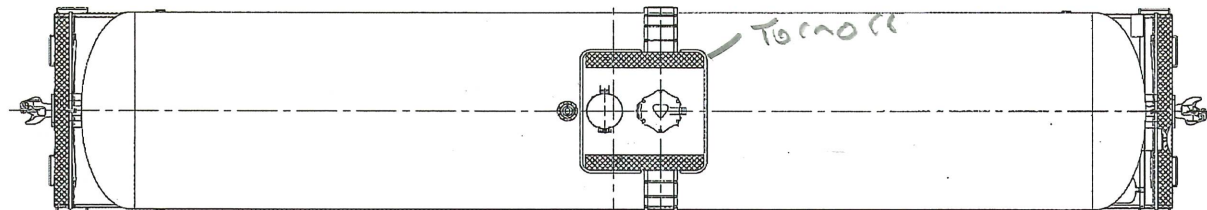
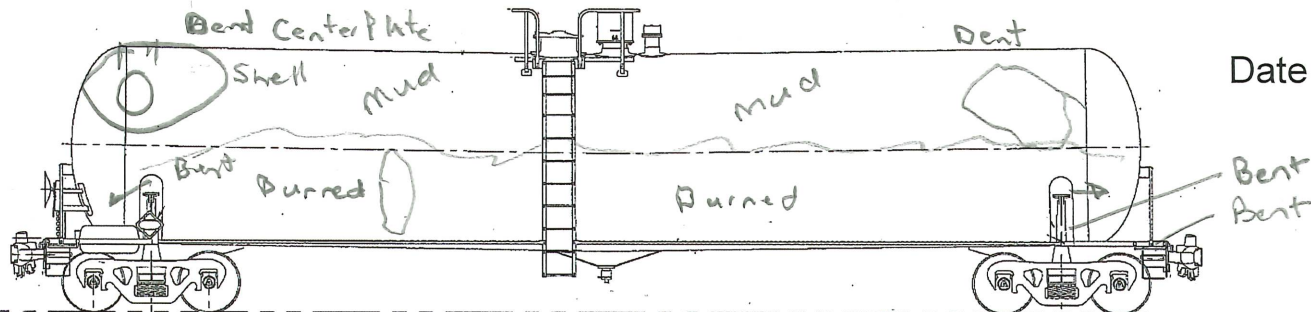

Builder Trinity

Built Date 10-28-20

DOT 117 J 100 W

File# T 19039

Loss of Commodity Yes / No 100%

Valves -Leaked / Sheared off

BOV

Top fittings MW OK MH OK

Bottom Outlet Leg Sheared Handle DT Torn off

Breach- Thermal Tear No Mech Tear No

Draft Sill A Torn open B OK inboard

Head Shield A OK Burned B Bent

PRD Functioned- Yes No ?

Empty

B couple  
731775 A

Hold

Skid missing BOV sheared

6

# Car Damage Report

3-12-15  
DGT-004  
Rev 4

Car Number TILX 731721

Wreck index Number 3

Consist 42

Date of Derailment 1-8-22

Location OKIA Union TX

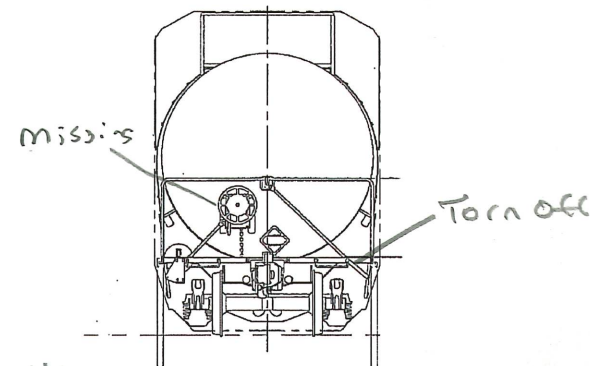
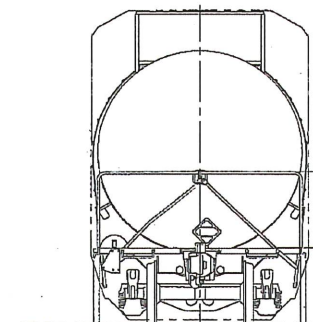
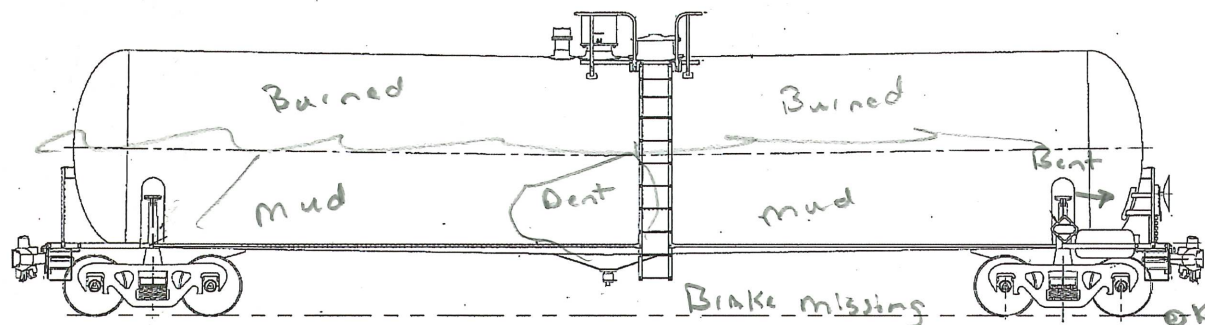
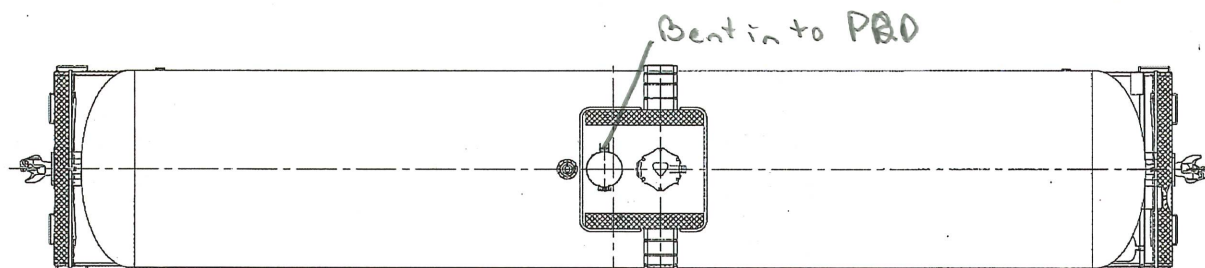
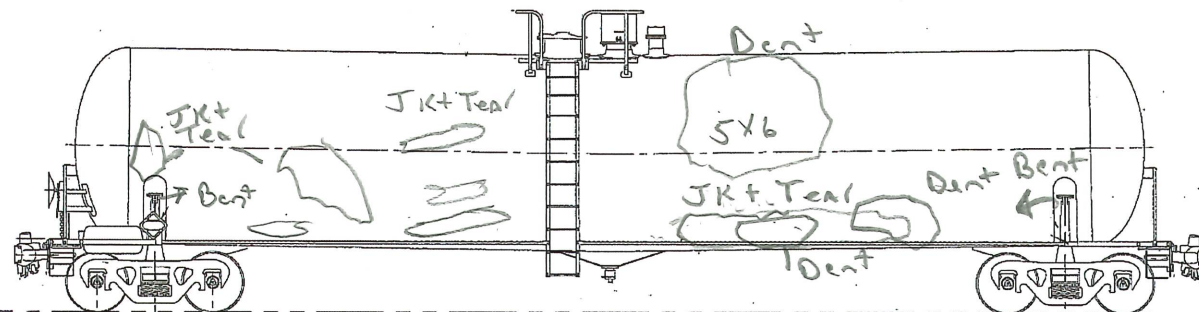

Builder Trinity  
 Built Date 10-28-70  
 DOT 117J100W  
 File# T19039  
 Loss of Commodity Yes / No  
 Valves -Leaked / Sheared No

Top fittings MW <sup>2 Eye bolts bent over</sup> MH Bent  
 Bottom Outlet Leg Sheared Handle DT Torn off  
 Breach- Thermal Tear No Mech Tear No  
 Draft Sill A Bent torn B Twisted  
 Head Shield A OK B OK  
 PRD Functioned- Yes No  
 Skid Damaged Stem bent

# Car Damage Report

3-12-15  
DGT-004  
Rev 4

Car Number TILX 731782

Wreck index Number 7

Consist 43

Date of Derailment 1-8-22

Location OKlaunion TX

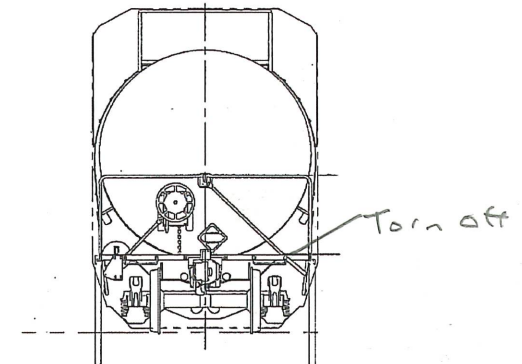
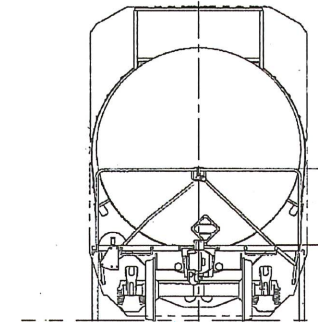
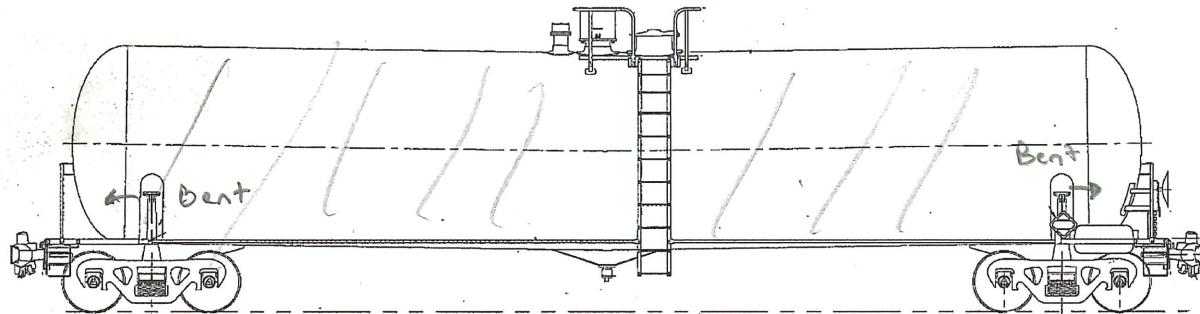
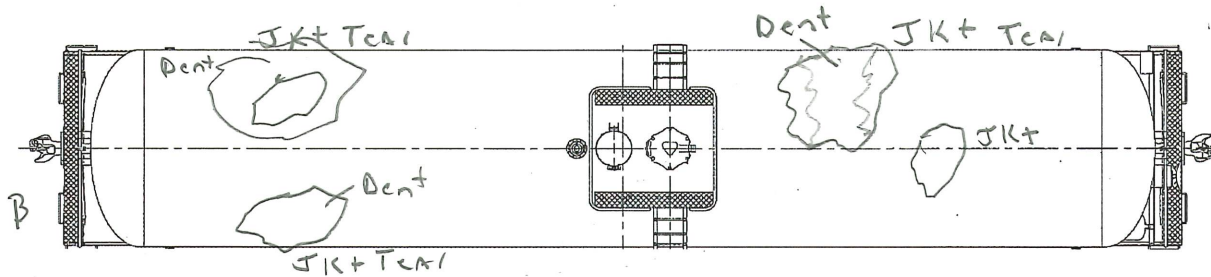
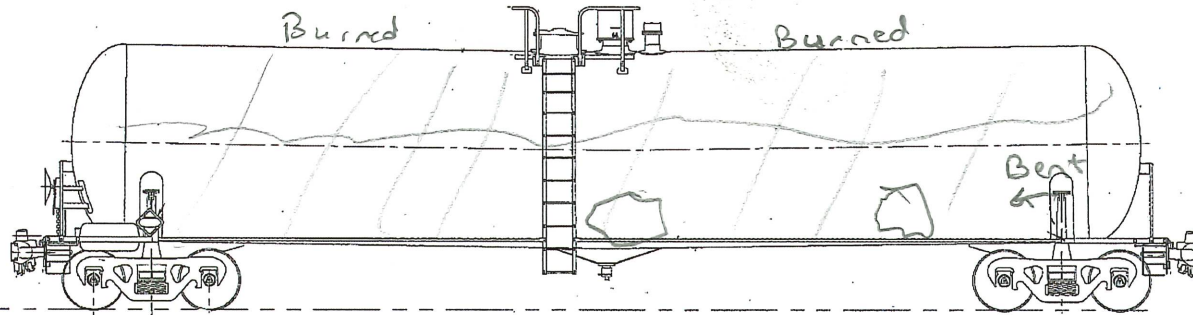

Builder Trinity

Built Date 10-28-20

DOT 1175100W

File# T19039

Loss of Commodity Yes / No

Valves -Leaked / Sheared No

Top fittings MW OK MH bent Egged

Bottom Outlet Leg Sheared Handle DT torn off

Breach- Thermal Tear No Mech Tear No

Draft Sill A Twisted B OK

Head Shield A OK B OK

PRD Functioned- Yes No

SKid Bent

A Coupler Sheared



# Car Damage Report

3-12-15  
DGT -004  
Rev 4

Car Number CRDX300110

Wreck index Number 11

Consist 44

Date of Derailment 1-8-22

Location DK Union Tx

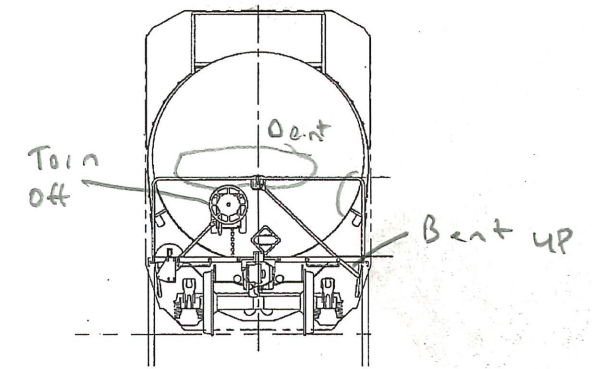
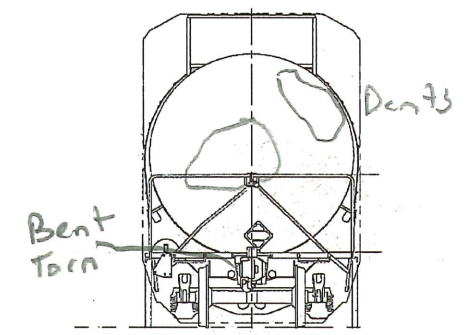
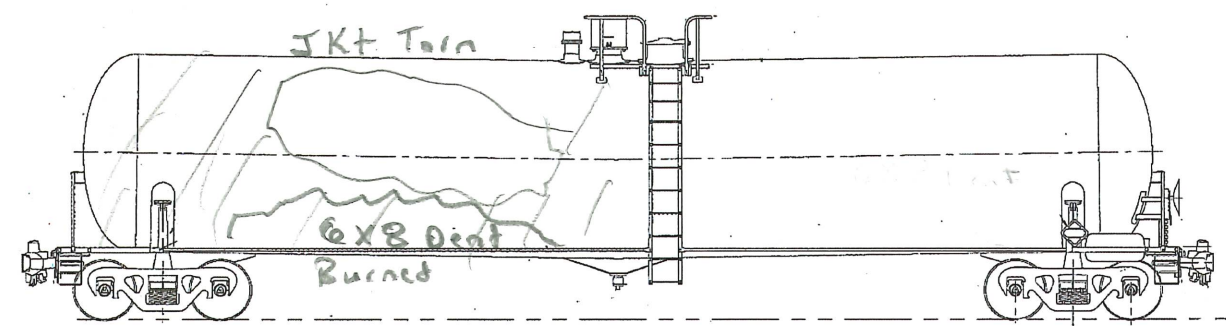
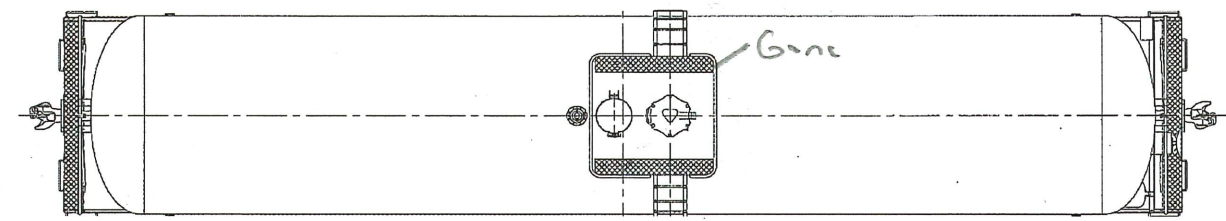
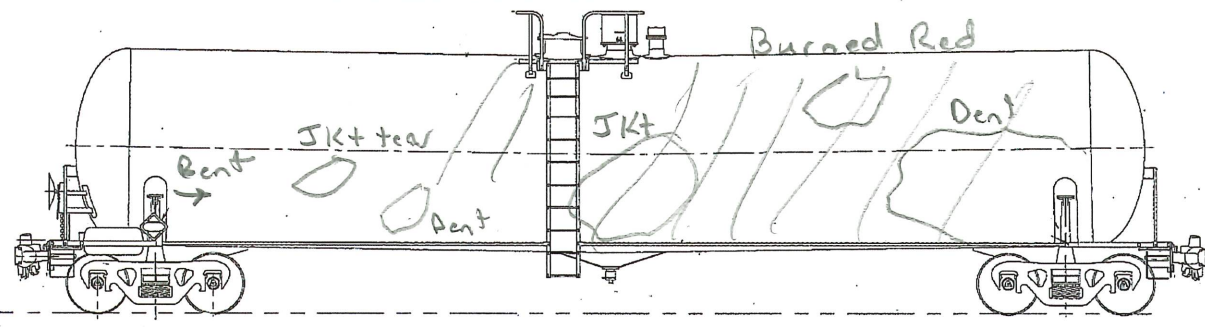

Builder Trinity  
 Built Date 12-4-15  
 DOT 117J100W  
 File# T15038  
 Loss of Commodity Yes No  
 Valves -Leaked / Sheared No

Top fittings MW OK MH Bent OK  
 Bottom Outlet Leg OK Handle DT OK bent  
 Breach- Thermal Tear No Mech Tear No  
 Draft Sill A Bent torn B OK  
 Head Shield A Dents B Dent  
 PRD Functioned- Yes No  
 SKid OK

1/4  
 Hold A End Sill Remove head shield

# Car Damage Report

13

3-12-15  
DGT-004  
Rev 4

Car Number CRDX 300070

Wreck index Number 13

Consist 45

Date of Derailment 1-8-23

Location OKLA Union TX

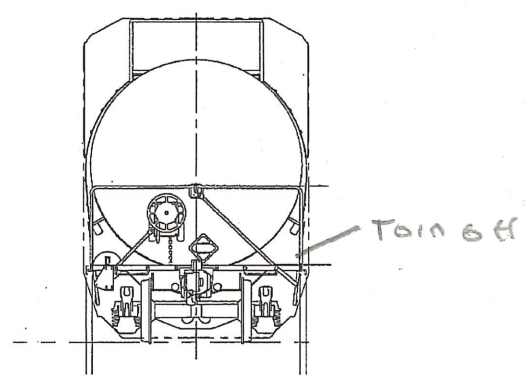
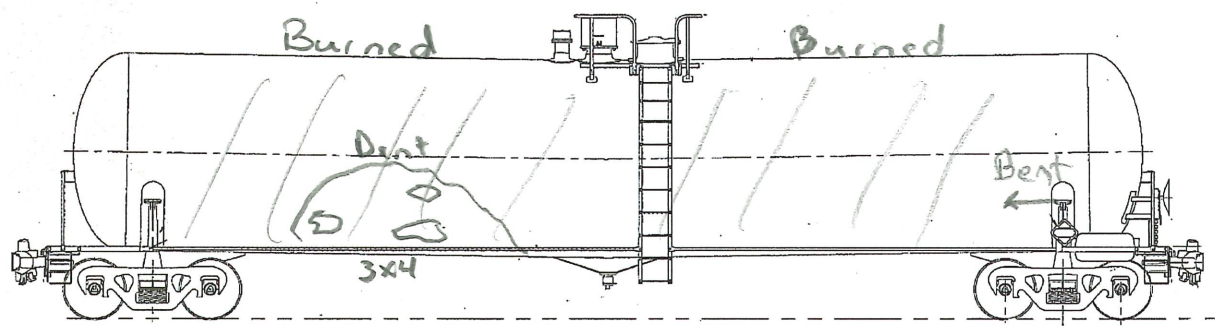
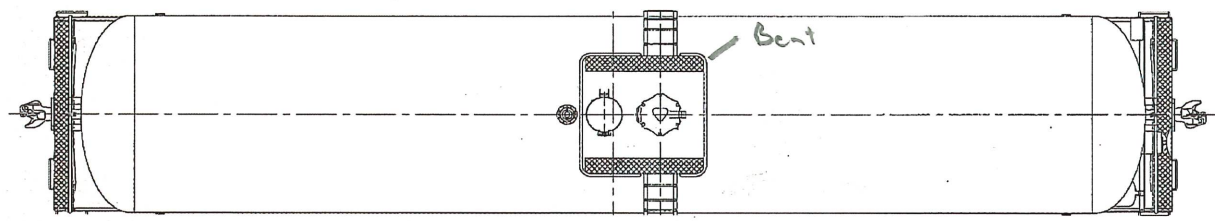
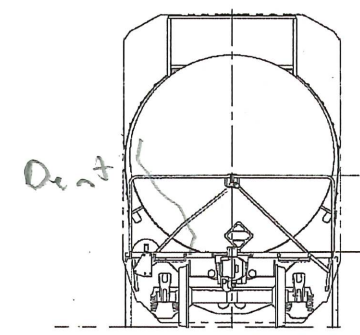
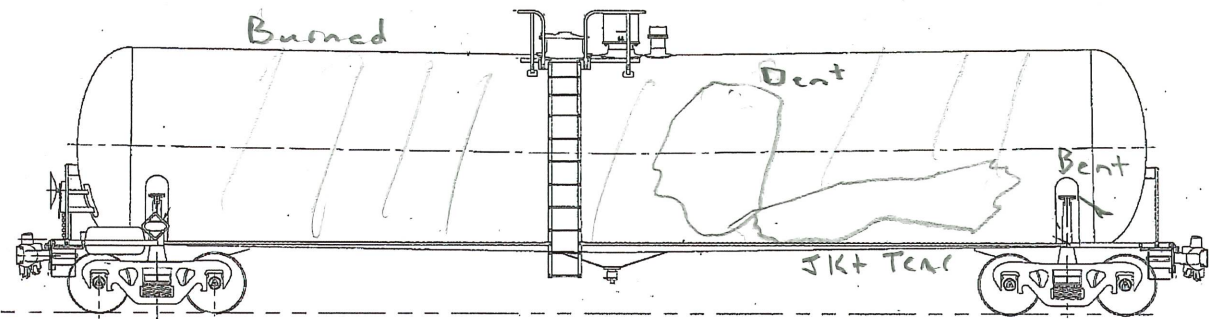

Builder Trinity  
Built Date 12-4-15  
DOT 117 J100W  
File# T15038  
Loss of Commodity (Yes) / No  
Valves -Leaked / Sheared

Top fittings MW OK MH OK  
Bottom Outlet Leg Sheared Handle DT bent  
Breach- Thermal Tear No Mech Tear No  
Draft Sill A Bent B Bent Coupler torn off  
Head Shield A Dent B OK  
PRD Functioned- (Yes) No  
SKid bent BDU hit

1/3

Hold A End remove head shield

# Car Damage Report

12

3-12-15  
DGT-004  
Rev 4

Car Number CRDX 300133

Wreck index Number 12

Consist 46

Date of Derailment 1-8-22

Location OKIA Union TX

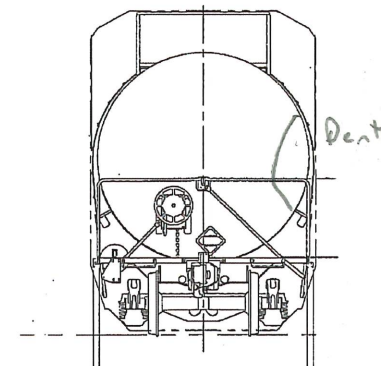
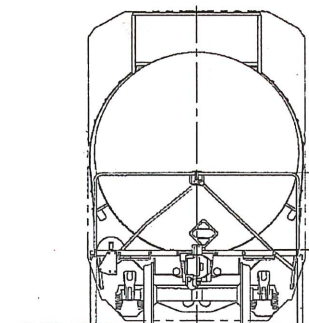
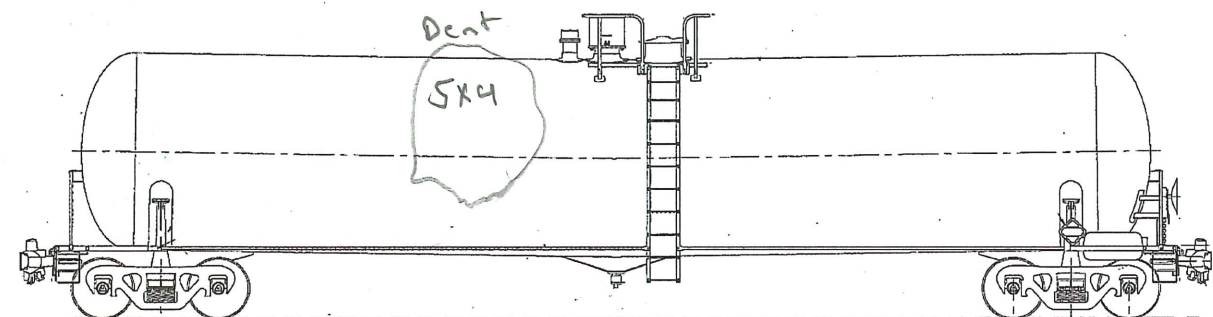
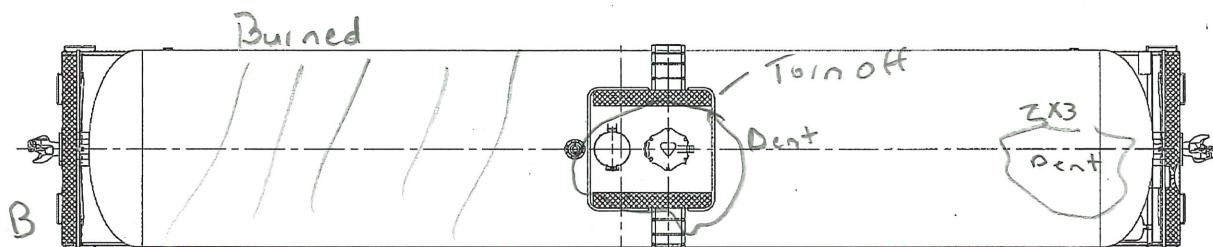
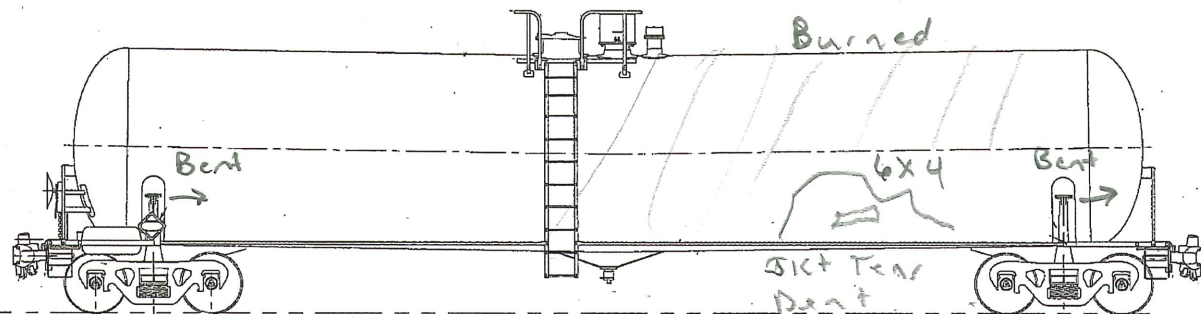

Builder Trinity

Built Date 12-8-15

DOT 117J100W

File# T15038

Loss of Commodity Yes / No

Valves Leaked / Sheared 3"

Top fittings MW OK MH Bent

Bottom Outlet Leg Sheared Handle DT Torn off

Breach- Thermal Tear No Mech Tear No

Draft Sill A Twisted B Twisted

Head Shield A OK B Dent

PRD Functioned- Yes No Burned

SKid Damaged BOU hit

? B End JKT

5

# Car Damage Report

3-12-15  
DGT-004  
Rev 4

Car Number TILX 731379

Wreck index Number 2

Consist 47

Date of Derailment 1-8-22

Location OKLA Union TX

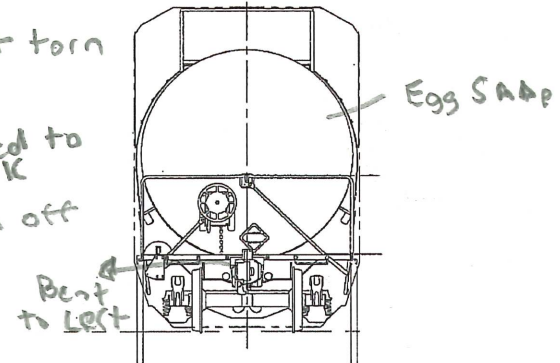
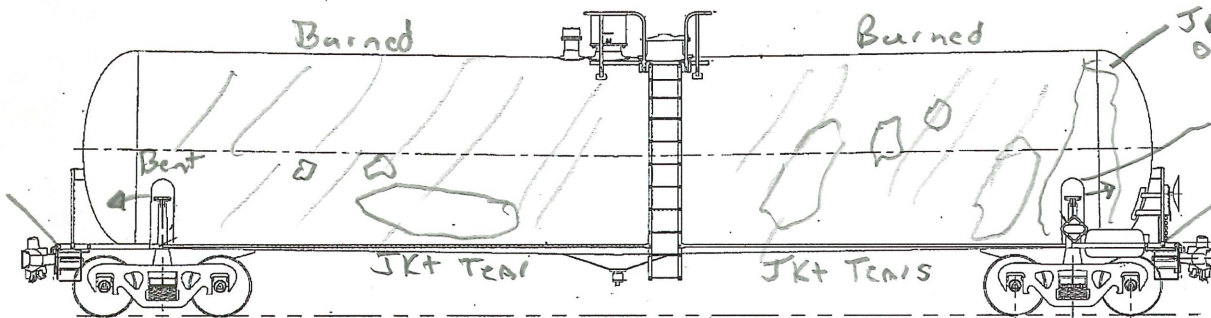
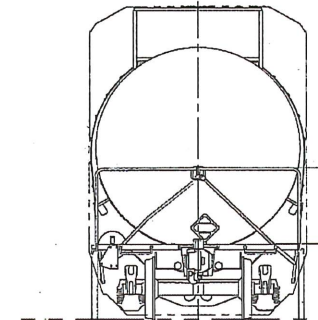
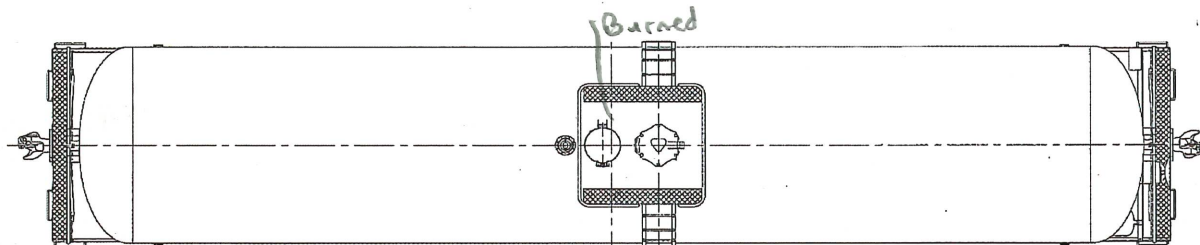
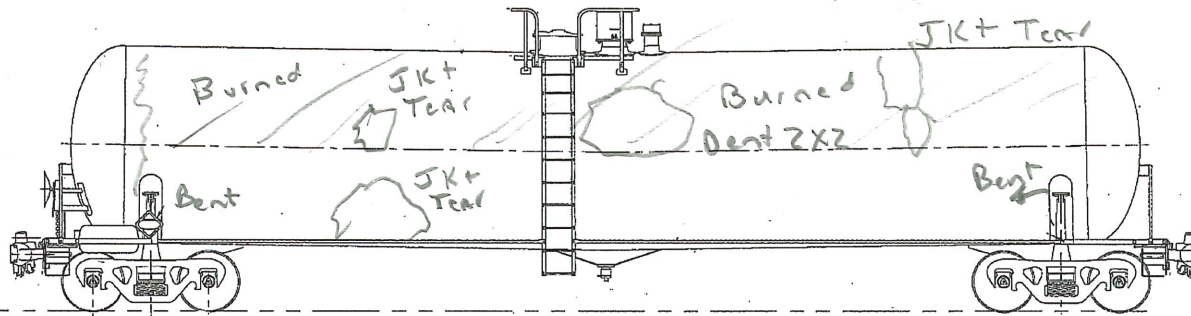

Builder Trinity

Built Date 3-12-20

DOT 1175100W

File# T19039

Loss of Commodity Yes / No

Valves -Leaked / Sheared BOV?

Buried

Top fittings MW OK MH OK

Bottom Outlet Leg Sheared Handle DT Missing

Breach- Thermal Tear No Mech Tear No

Draft Sill A OK B Bent

Head Shield A OK B Egg Shape

PRD Functioned- Yes No

Skid Damaged

731462 A End Coupled to B end

# Car Damage Report

30  
3-12-15  
DGT-004  
Rev 4

Car Number TILX 731462

Wreck index Number 8

Consist 48

Date of Derailment 1-8-22

Location OKLAHOMA TX

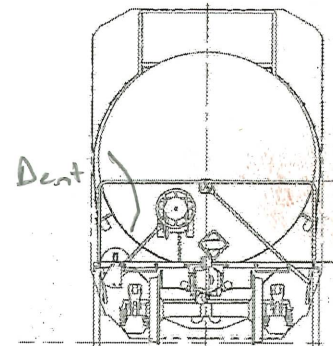
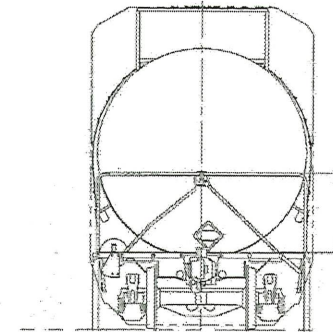
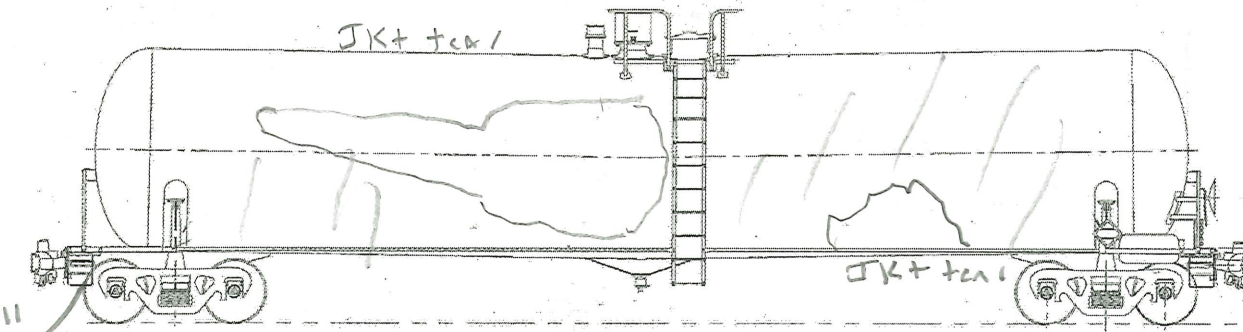
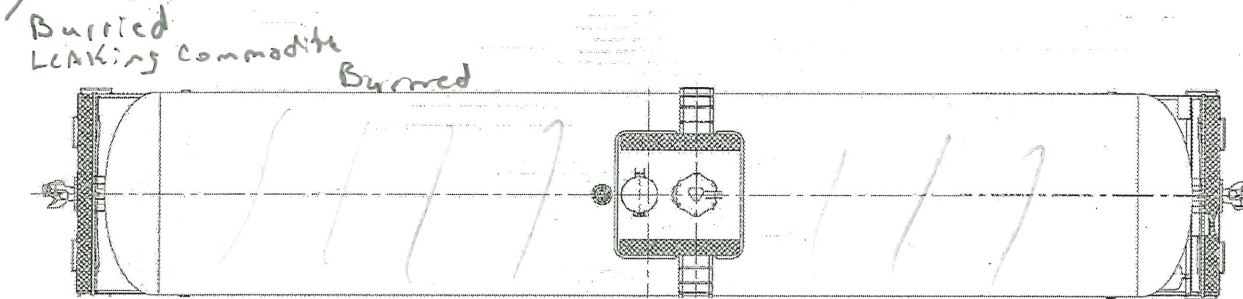
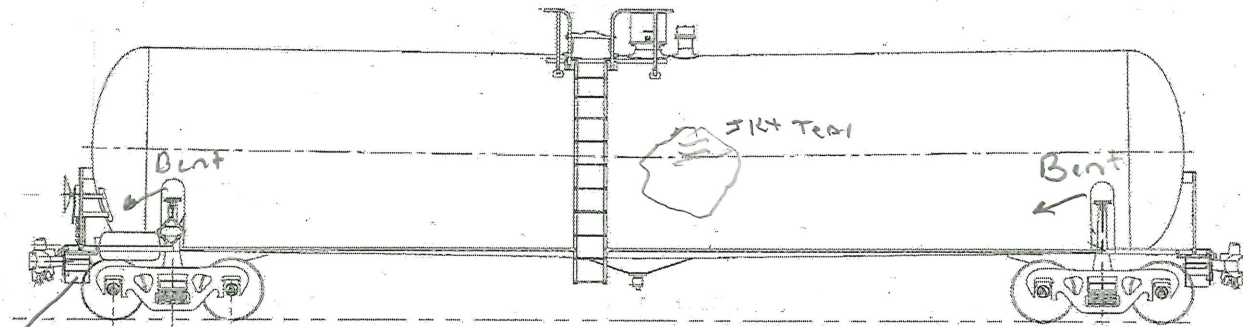

Stub Sill  
Torn off  
@ HB  
inspect  
Empty  
Hold

Builder Trinity  
Built Date 3-17-20  
DOT 117J100W  
File# T19039  
Loss of Commodity Yes/No  
Valves -Leaked / Sheared All Top Valves

Top fittings MW OK MH Egg Shape  
Bottom Outlet Leg Sheared Handle DT torn off  
Breach- Thermal Tear No Mech Tear No  
Draft Sill A torn off B Dent  
Head Shield A OK B OK  
PRD Functioned- Yes (No)  
SICID OK

Housing & Valves Sheared off

19

# Car Damage Report

3-12-15  
DGT-004  
Rev 4

Car Number TILX 731464

Wreck index Number 21 Consist 49

Date of Derailment 1-8-22

Location OKLA Union Tx

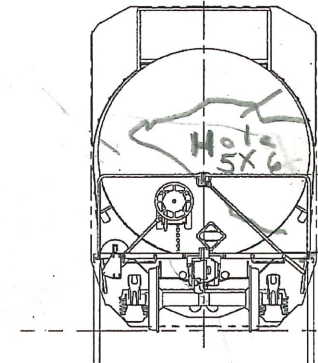
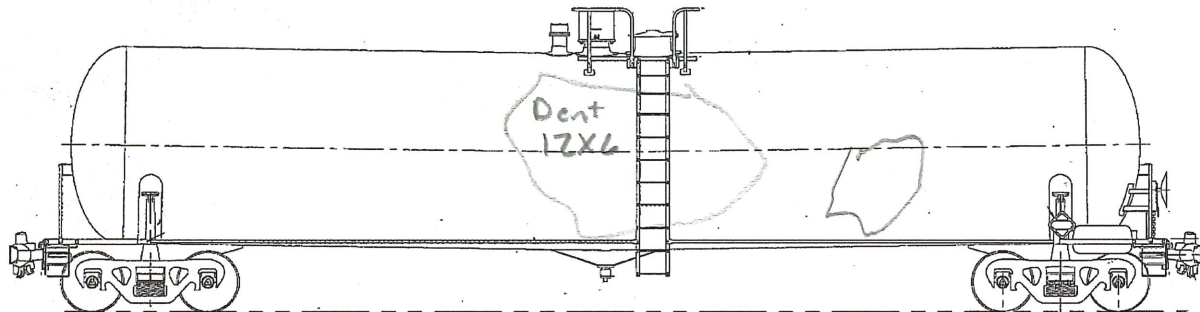
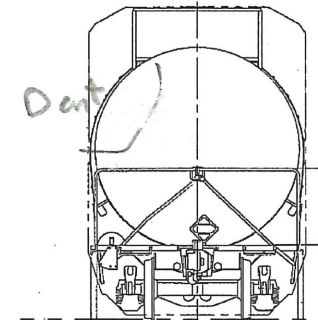
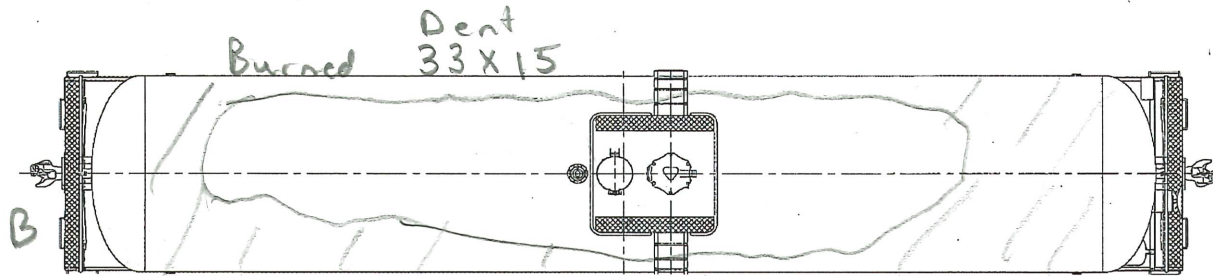
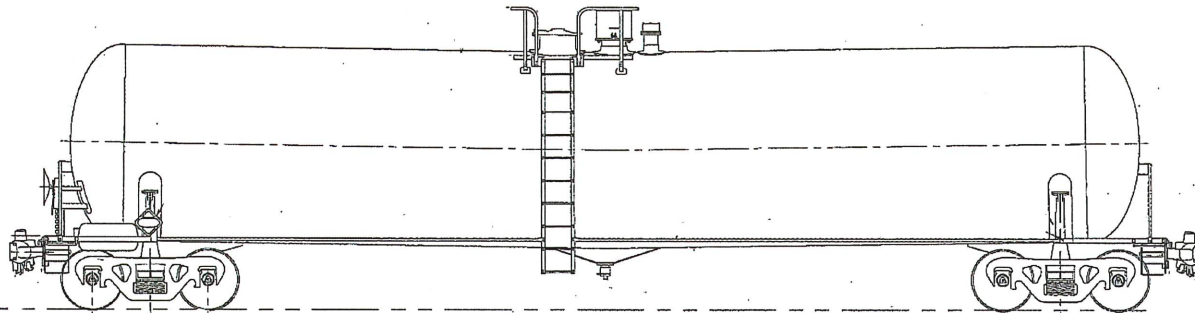

See Pic  
TANK Shell  
Head  
Shield  
Torn off

Builder Trinity

Built Date 3-12-20

DOT 1175100W

File# T19039

Loss of Commodity Yes / No All

Valves -Leaked / Sheared No

Top fittings MW Bent MH Bent

Bottom Outlet Leg Sheared Handle DT Bent

Breach- Thermal Tear No Mech Tear B head + Shell

Draft Sill A Bent B Bent

Head Shield A Dent B Torn off

PRD Functioned- Yes No

SKid Bent

1 Bolt Sheared

Hold  
B end Head shield stub sill

# Car Damage Report

⑤

3-12-15  
DGT-004  
Rev 4

Car Number TILX 731464

Wreck index Number \_\_\_\_\_

Consist 49

Date of Derailment 1-27-22 <sup>Inspection</sup> Additional

Location OKlaunion TX

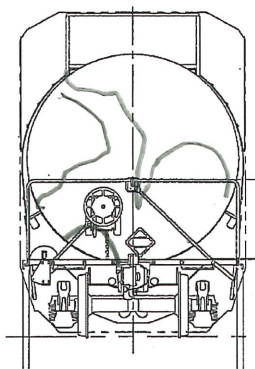
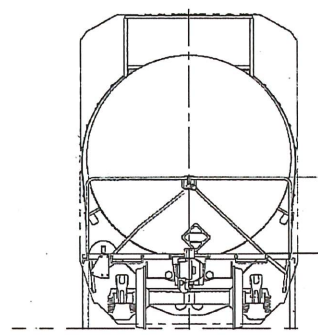
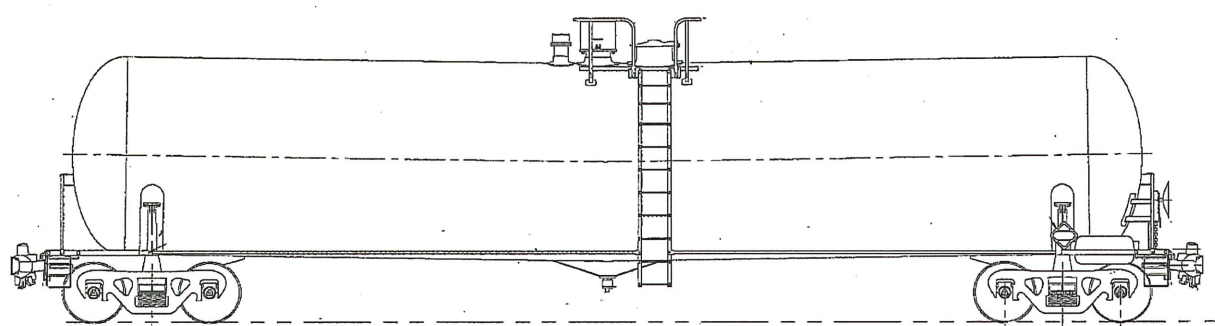
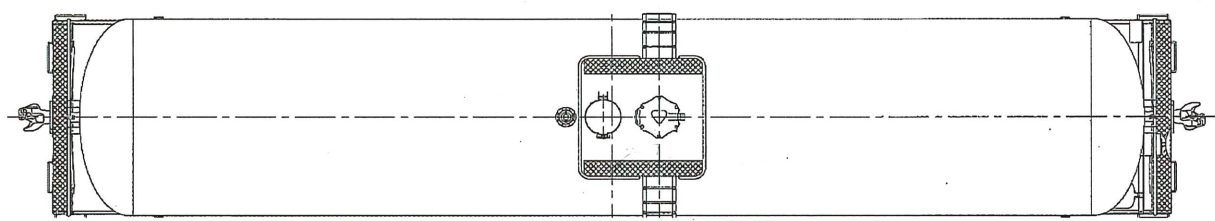
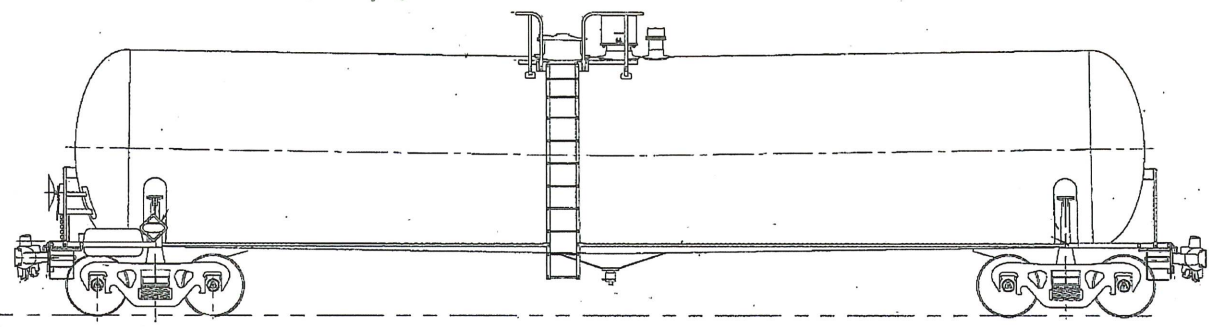

Head torn  
Several Directions

Head brace  
to Sill 14 mm

Side impact

Builder \_\_\_\_\_  
Built Date \_\_\_\_\_  
DOT \_\_\_\_\_  
File# \_\_\_\_\_  
Loss of Commodity Yes / No  
Valves -Leaked / Sheared

Top fittings MW \_\_\_\_\_ MH \_\_\_\_\_  
Bottom Outlet Leg \_\_\_\_\_ Handle \_\_\_\_\_ DT \_\_\_\_\_  
Breach- Thermal Tear \_\_\_\_\_ Mech Tear \_\_\_\_\_  
Draft Sill A \_\_\_\_\_ B \_\_\_\_\_  
Head Shield A \_\_\_\_\_ B \_\_\_\_\_  
PRD Functioned- Yes \_\_\_\_\_ No \_\_\_\_\_

# Car Damage Report

17

3-12-15  
DGT-004  
Rev 4

Car Number TILX 731426

Wreck index Number 18

Consist 50

Date of Derailment 1-8-22

Location OKIAunion Tx

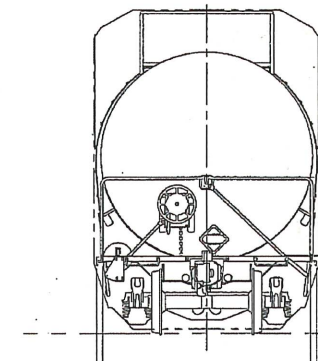
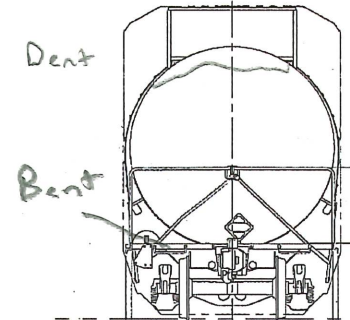
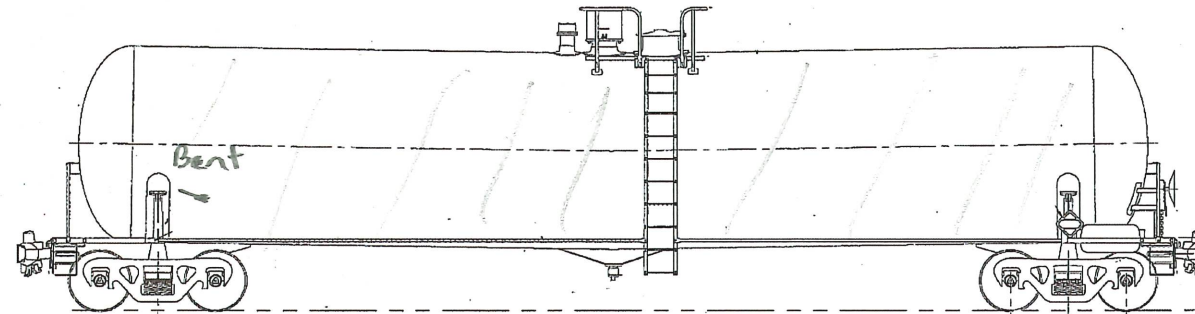
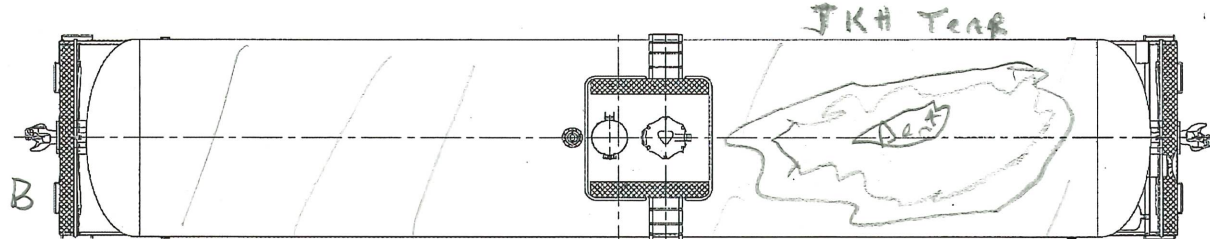
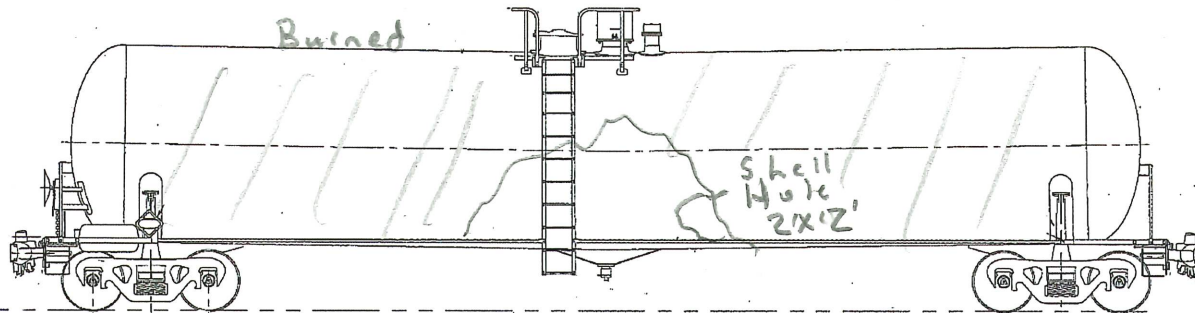

Builder Trinity

Built Date 3-12-20

DOT 117J100W

File# T19039

Loss of Commodity Yes / No

Valves -Leaked / Sheared

PRD Functioned- Yes / No

Top fittings MW OK MH Bent

Bottom Outlet Leg Sheared Handle DT

Breach- Thermal Tear No Mech Tear 2x2

Draft Sill A Twisted B Twisted

Head Shield A OK B OK

PRD Functioned- Yes / No

SKid bent

Bent  
CR side

Hold inspect center shell hole - Roll / remove Dirt



6

# Car Damage Report

3-12-15  
DGT -004  
Rev 4

Car Number TILX731426

Wreck index Number \_\_\_\_\_

Consist 50

Inspection  
Date of Derailment 1-27-22 Additional

Location OK Union Tx

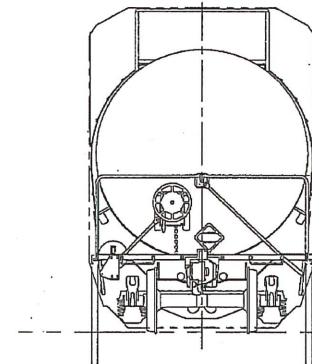
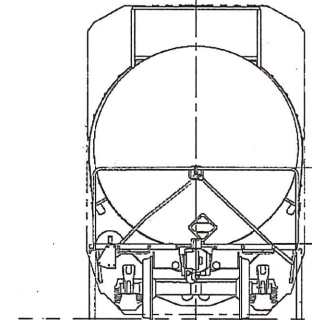
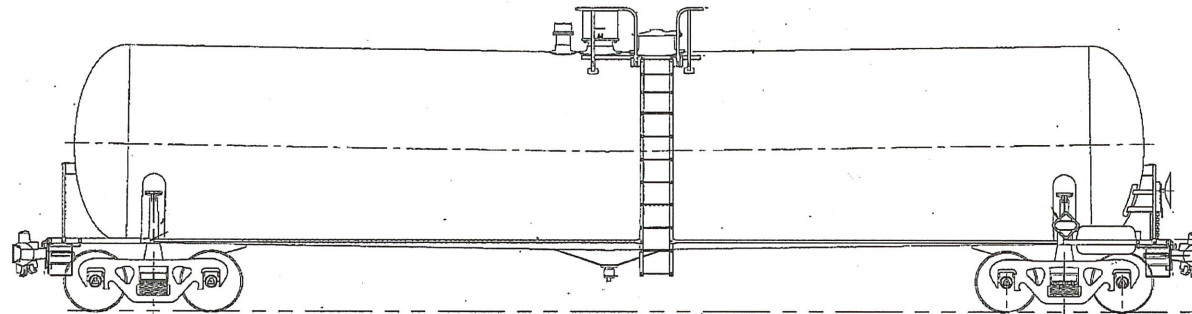
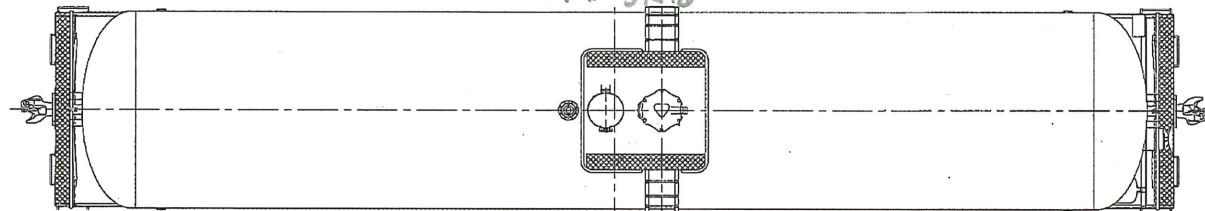
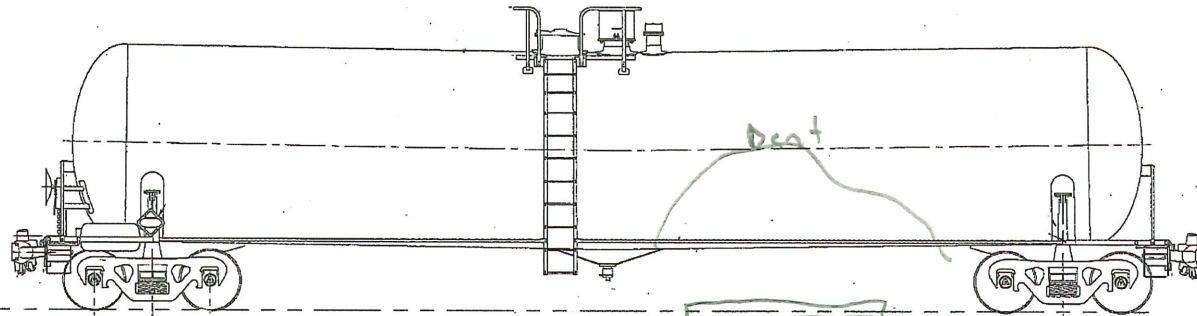

Builder \_\_\_\_\_  
 Built Date \_\_\_\_\_  
 DOT \_\_\_\_\_  
 File# \_\_\_\_\_  
 Loss of Commodity Yes / No  
 Valves -Leaked / Sheared

Top fittings MW \_\_\_\_\_ MH \_\_\_\_\_  
 Bottom Outlet Leg \_\_\_\_\_ Handle \_\_\_\_\_ DT \_\_\_\_\_  
 Breach- Thermal Tear \_\_\_\_\_ Mech Tear \_\_\_\_\_  
 Draft Sill A \_\_\_\_\_ B \_\_\_\_\_  
 Head Shield A \_\_\_\_\_ B \_\_\_\_\_  
 PRD Functioned- Yes \_\_\_\_\_ No \_\_\_\_\_

# Car Damage Report

3-12-15  
DGT -004  
Rev 4

19

Car Number TILX 731748 Wreck index Number 10 Consist 51

Date of Derailment 1-8-22

Location OKlaunion TX

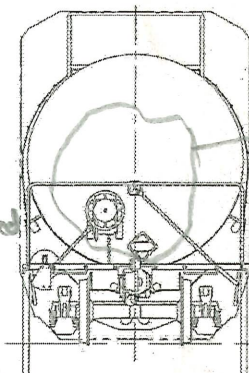
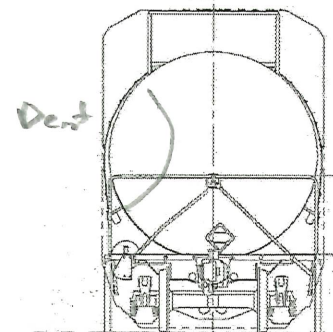
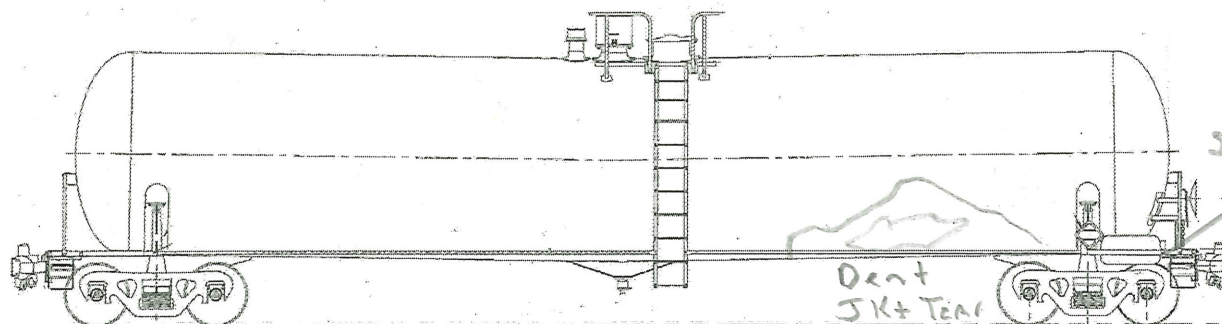
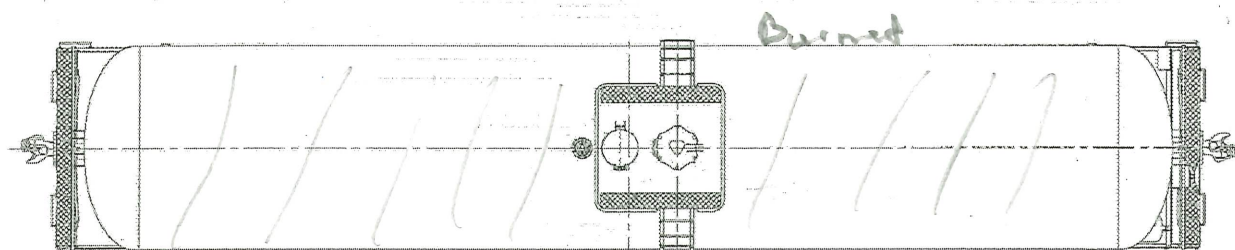
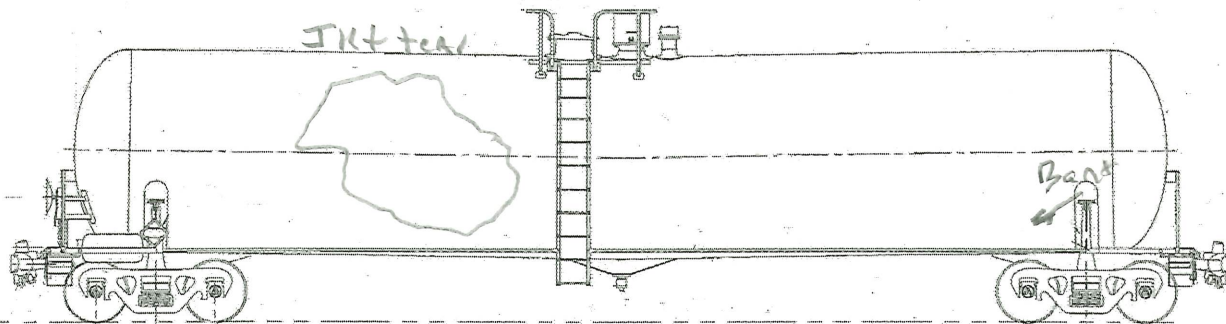

Builder Trinity  
Built Date 10-16-20  
DOT 117J100W  
File# T19039  
Loss of Commodity Yes / No  
Valves -Leaked / Sheared NO

Top fittings MW Leaking MH OK  
Bottom Outlet Leg Sheared Handle DT torn off  
Breach- Thermal Tear No Mech Tear No  
Draft Sill A torn off B HB crack to pad torn off  
Head Shield A Dent B Dent 6x6  
PRD Functioned- Yes No  
SKid Bent  
1 Eye bolt Sheared

# Car Damage Report

9

3-12-15  
DGT-004  
Rev 4

Car Number TILX 731748

Wreck index Number 10

Consist 51

Date of Derailment <sup>Inspection</sup> 1-27-22 Additional

Location Oklaunion

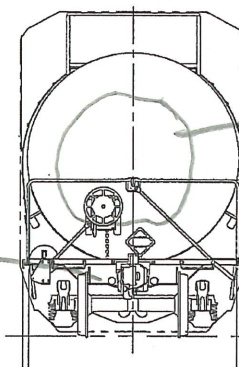
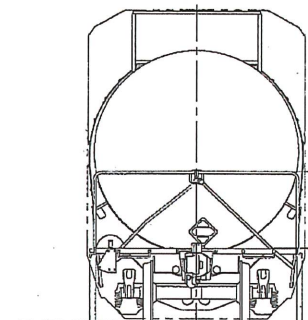
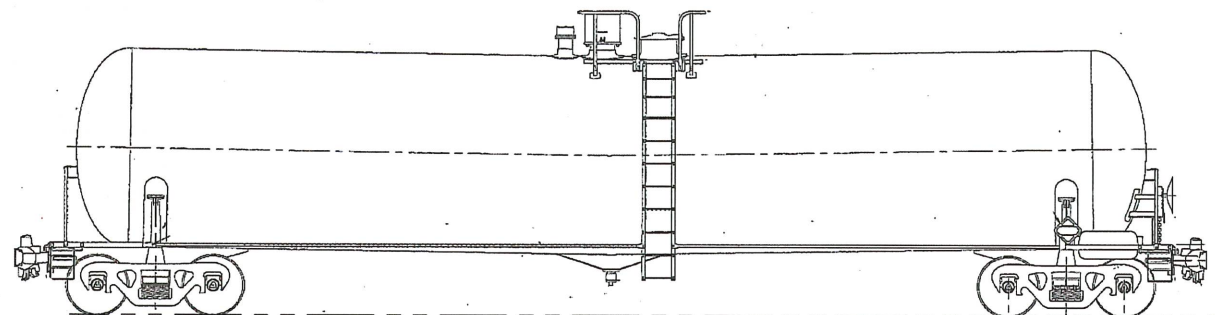
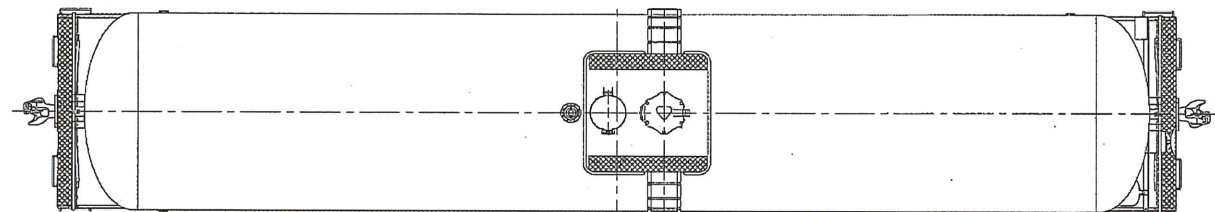
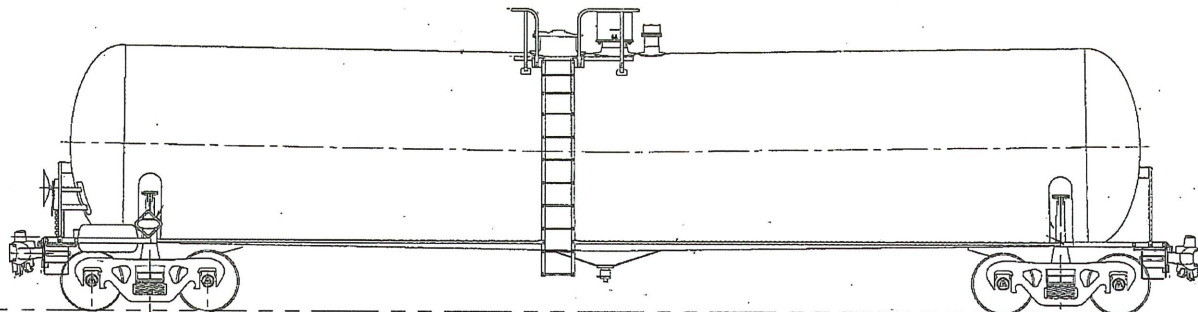

Pad Separated  
1" from weld  
Bent in w Dent  
Dent

28" weld separation

Sill torn  
off at  
Head brace

Builder \_\_\_\_\_  
Built Date \_\_\_\_\_  
DOT \_\_\_\_\_  
File# \_\_\_\_\_  
Loss of Commodity Yes / No  
Valves -Leaked / Sheared

Top fittings MW MH  
Bottom Outlet Leg Handle DT  
Breach- Thermal Tear Mech Tear  
Draft Sill A B  
Head Shield A B  
PRD Functioned- Yes No

HB crack  
3 1/2"  
to PAD AT TOP



# Car Damage Report

3-12-15  
DGT-004  
Rev 4

Car Number TILX 731754

Wreck index Number 9

Consist 52

Date of Derailment 1-8-22

Location Oklahoma TX

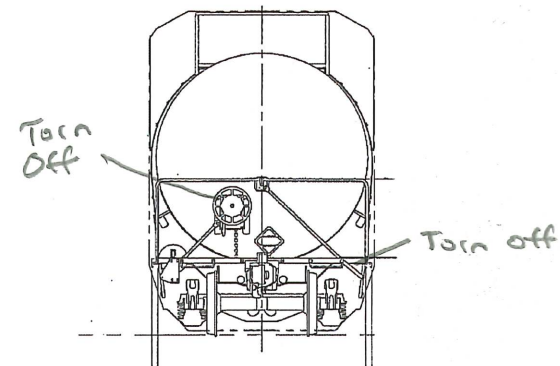
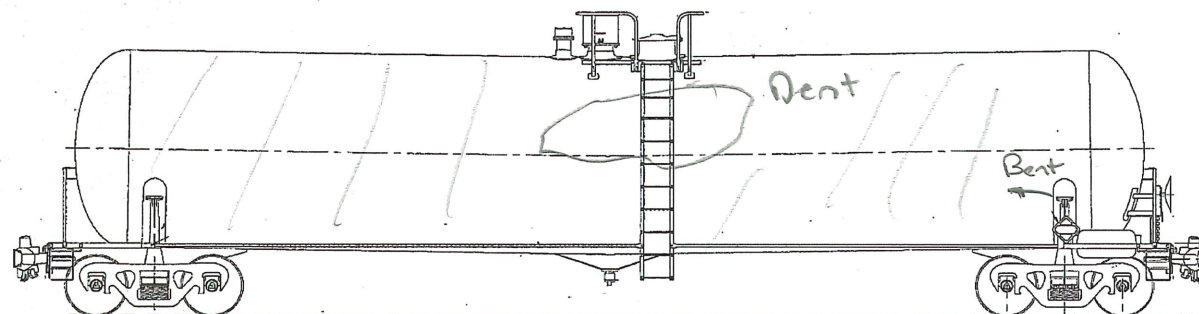
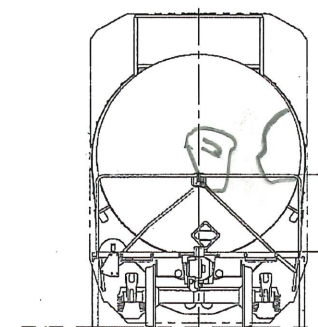
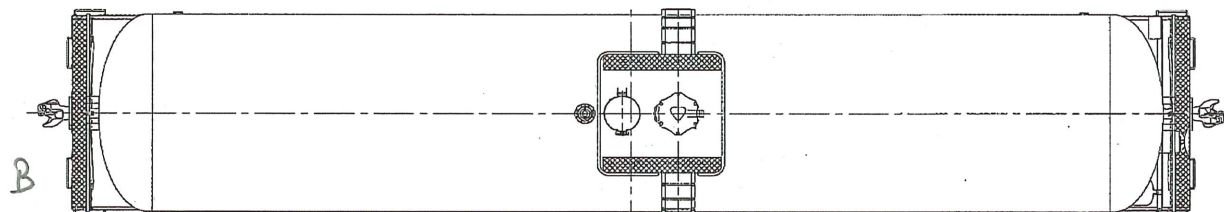
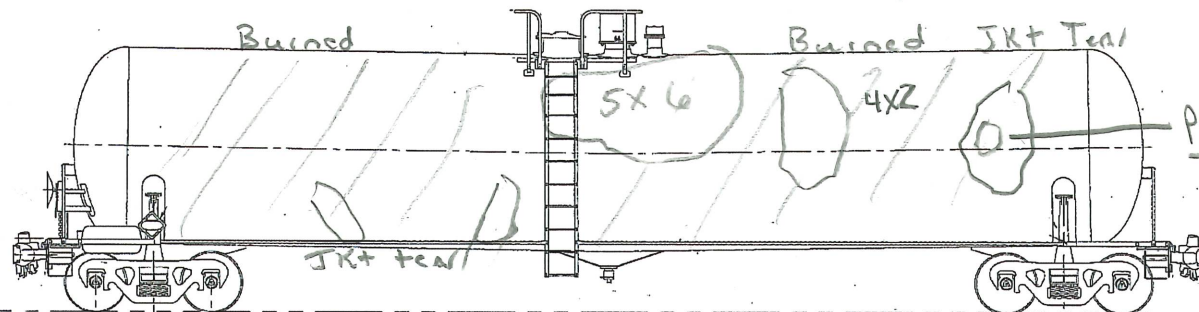

Builder Trinity  
 Built Date 10-16-20  
 DOT 1175100W  
 File# T19039  
 Loss of Commodity  Yes / No  
 Valves -Leaked / Sheared

Top fittings MW OK MH OK  
 Bottom Outlet Legs sheared Handle DT torn off  
 Breach- Thermal Tear No Mech Tear AR Shell Breach  
 Draft Sill A Bent B Bent  
 Head Shield A Dents B OK  
 PRD Functioned- Yes  No  
 Skid bent Lock fouling skid

1/00

# Car Damage Report

3-12-15  
DGT-004  
Rev 4

31

Car Number TILX731717

Wreck index Number 4

Consist 53

Date of Derailment 1-8-22

Location OKlaunion TX

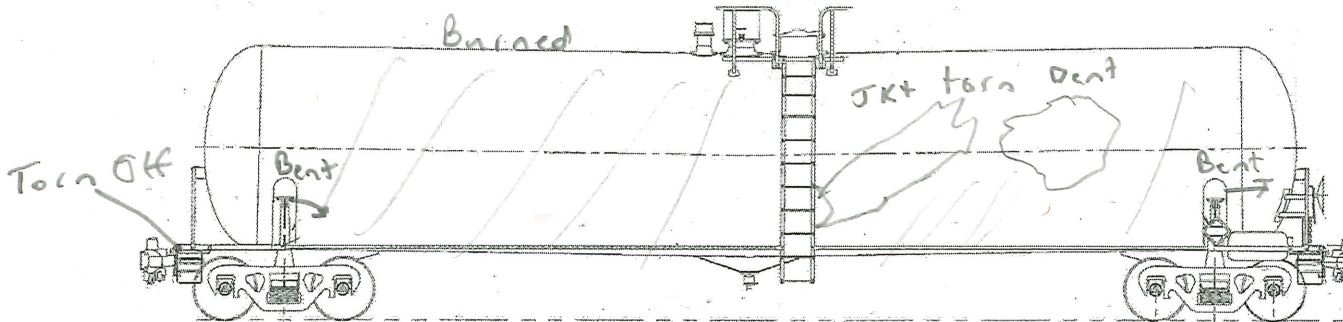
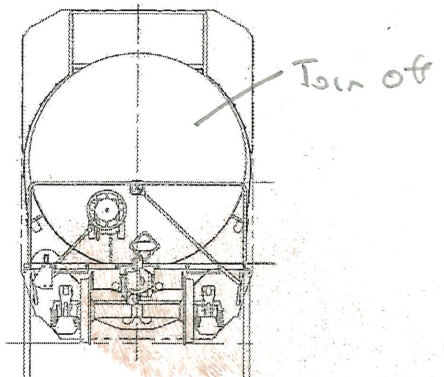
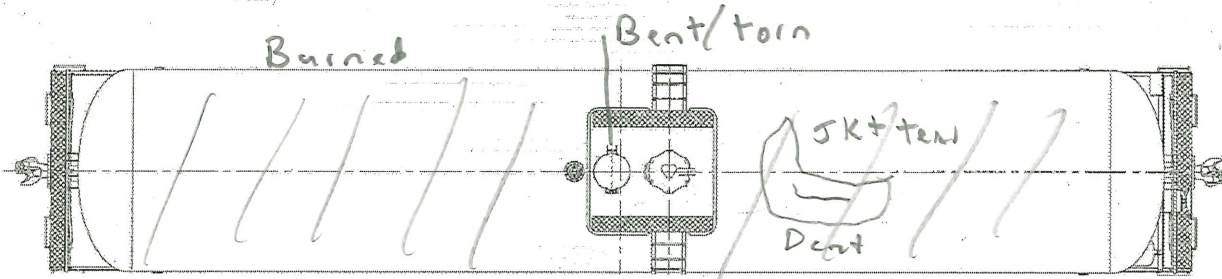
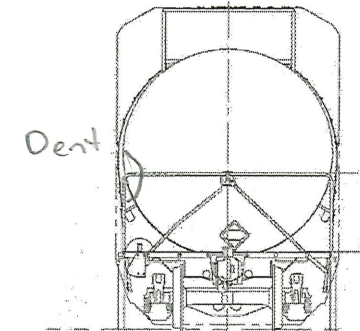
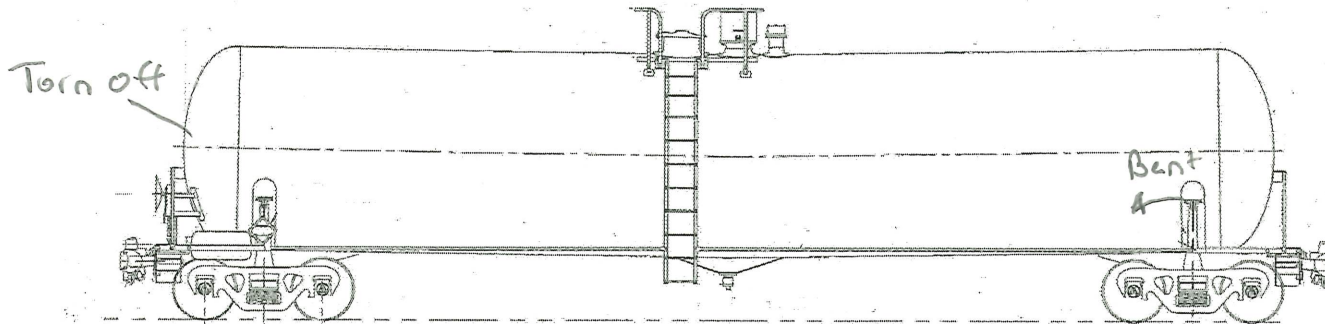

Builder Trinity  
 Built Date 10-16-20  
 DOT 117J100W  
 File# T19039  
 Loss of Commodity Yes / No  
 Valves -Leaked / Sheared No

Top fittings MW OK MH Bent  
 Bottom Outlet Leg sheared Handle DT bent  
 Breach- Thermal Tear No Mech Tear No  
 Draft Sill A OK left sheared B torn off  
 Head Shield A Dent B Torn off  
 PRD Functioned- Yes No  
 Skid OK

14

# Car Damage Report

3-12-15  
DGT-004  
Rev 4

Car Number TILX 731739

Wreck index Number 14 Consist 54

Date of Derailment 1-8-22

Location OKIA UNION TX

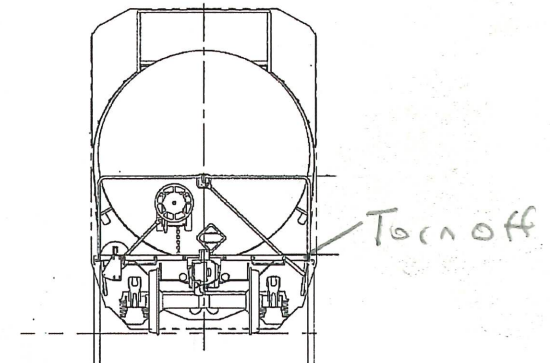
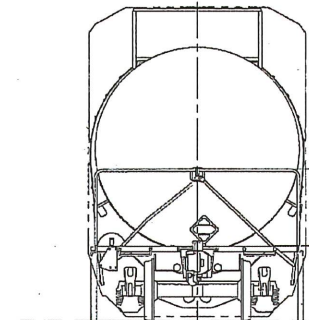
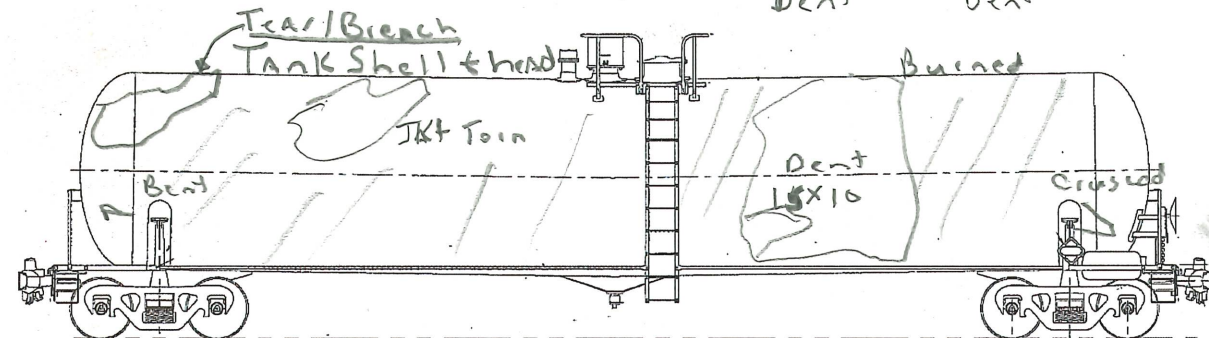
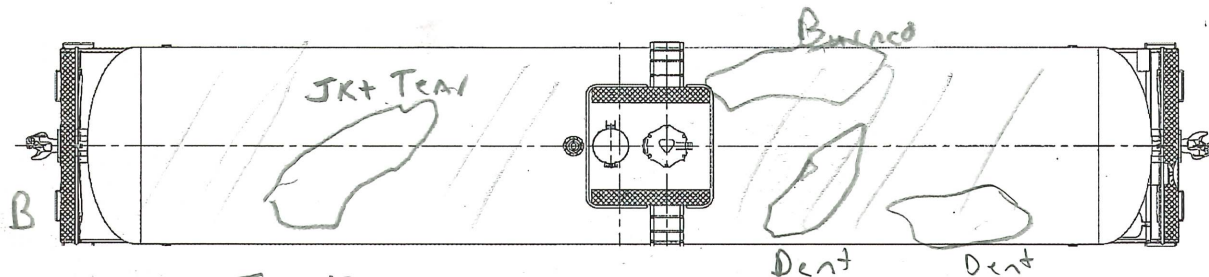
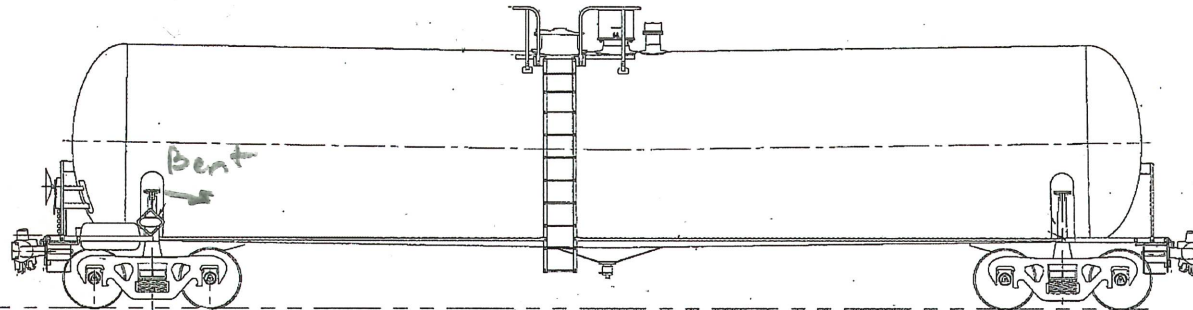

Builder Trinity

Built Date 10-16-20

DOT 117J100W

File# T19039

Loss of Commodity Yes / No

Valves -Leaked / Sheared BOV

Top fittings MW OK MH OK

Bottom Outlet Leg Sheared Handle DT turn off

Breach- Thermal Tear No Mech Tear YES: A End Tank & head

Draft Sill A OK B Bent

Head Shield A Torn B OK

PRD Functioned- Yes No

SKid Damaged torn BOV sheared off

Hold - BOV sheared off

8

# Car Damage Report

3-12-15  
DGT -004  
Rev 4

Car Number TLLX731739

Wreck index Number \_\_\_\_\_

Consist 54

Date of Derailment <sup>Inspection</sup> 1-27-22 Additional \_\_\_\_\_

Location OKLA Union Tx

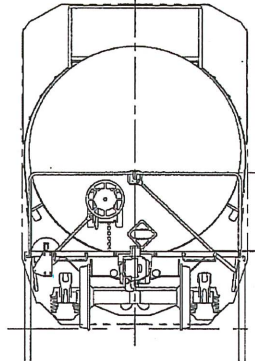
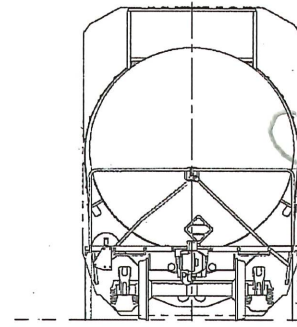
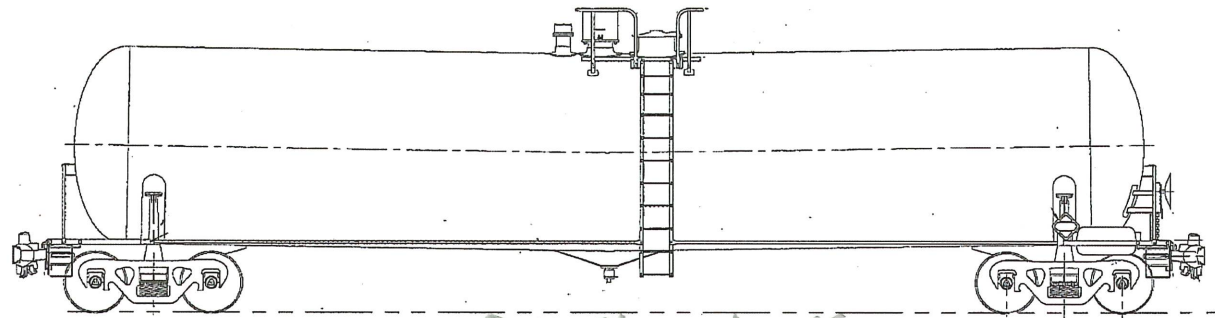
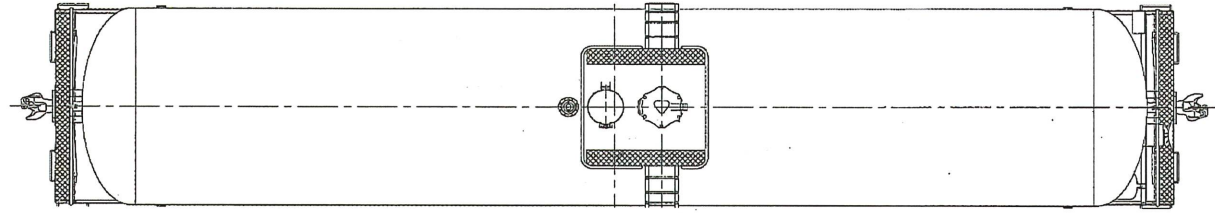
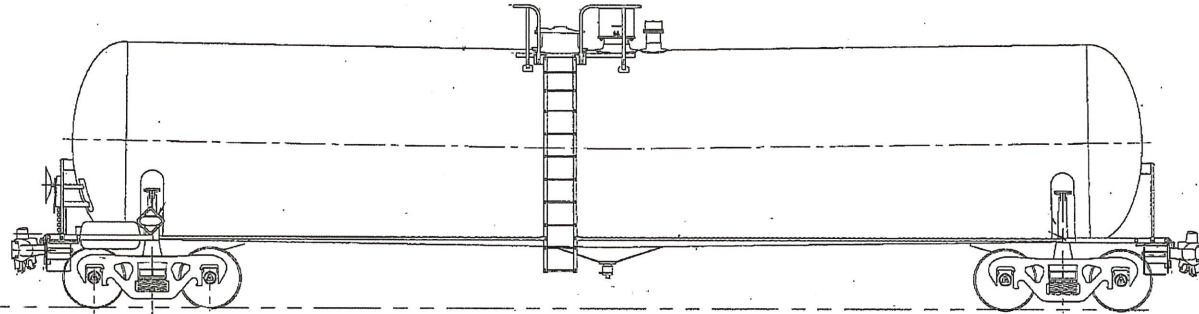

A Head removed  
Head + shell  
torn  
12' x 20"

BOU Sheared off

Builder \_\_\_\_\_  
Built Date \_\_\_\_\_  
DOT \_\_\_\_\_  
File# \_\_\_\_\_  
Loss of Commodity Yes / No  
Valves -Leaked / Sheared

Top fittings MW \_\_\_\_\_ MH \_\_\_\_\_  
Bottom Outlet Leg \_\_\_\_\_ Handle \_\_\_\_\_ DT \_\_\_\_\_  
Breach- Thermal Tear \_\_\_\_\_ Mech Tear \_\_\_\_\_  
Draft Sill A \_\_\_\_\_ B \_\_\_\_\_  
Head Shield A \_\_\_\_\_ B \_\_\_\_\_  
PRD Functioned- Yes \_\_\_\_\_ No \_\_\_\_\_

# Car Damage Report

3-12-15  
DGT-004  
Rev 4

28

Car Number TILX 731726

Wreck index Number 16

Consist 55

Date of Derailment 1-8-22

Location OKLAHOMA TX

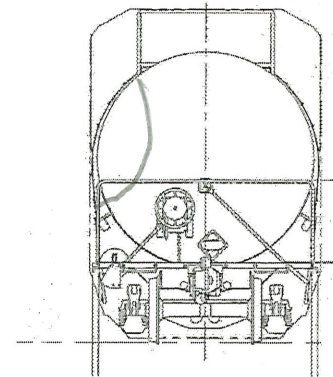
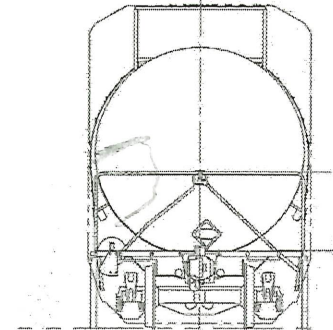
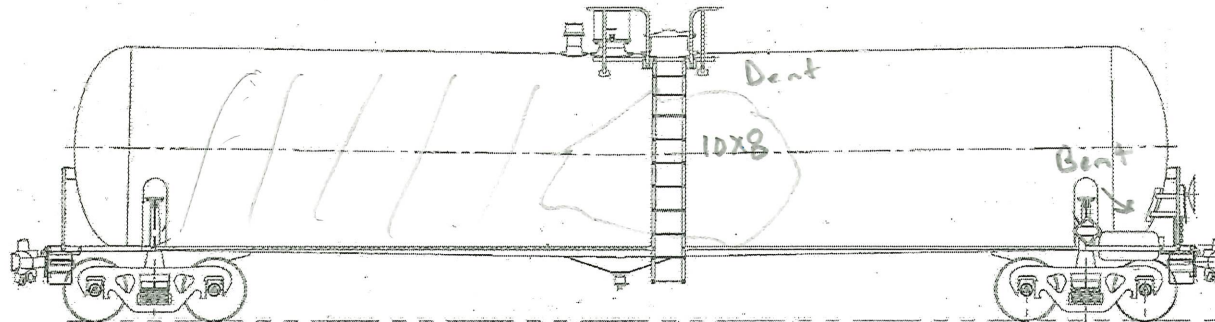
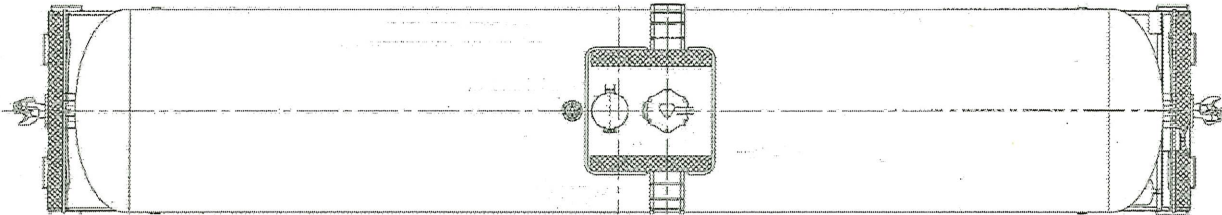
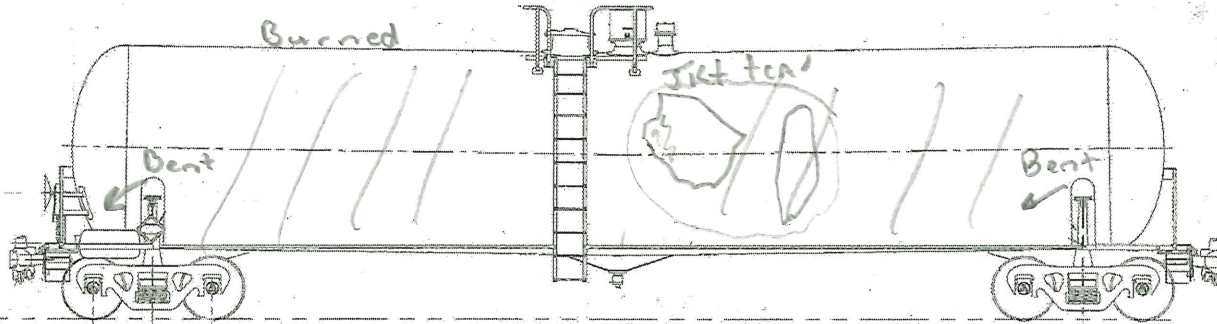

Builder Trinity  
 Built Date 10-14-20  
 DOT 117J100W  
 File# T19039  
 Loss of Commodity Yes / No  
 Valves -Leaked / Sheared ?

Top fittings MW OK MH OK  
 Bottom Outlet Leg ? Handle DT ?  
 Breach- Thermal Tear No Mech Tear No  
 Draft Sill A OK B Bent  
 Head Shield A Dent B Dent  
 PRD Functioned- Yes No  
 Skid buried ?

Hold  
Roll  
B stub HB  
SKid



# Car Damage Report

Hold BR hole

Car Number ERDX 300077

Wreck index Number 26 Consist 56

Date of Derailment 1-8-22

Location DKLA Union TX

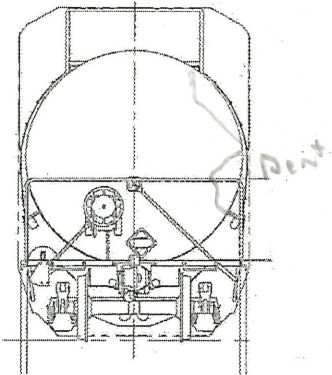
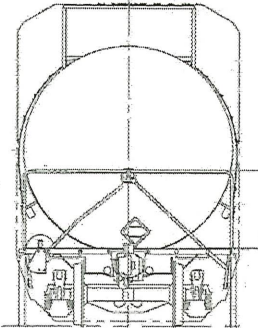
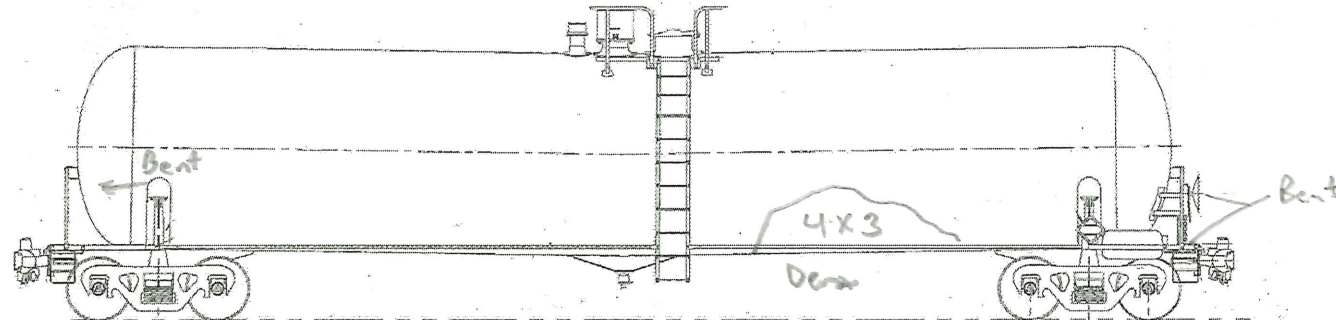
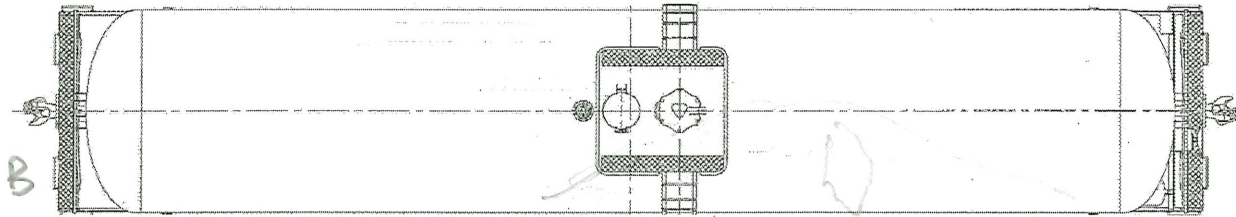
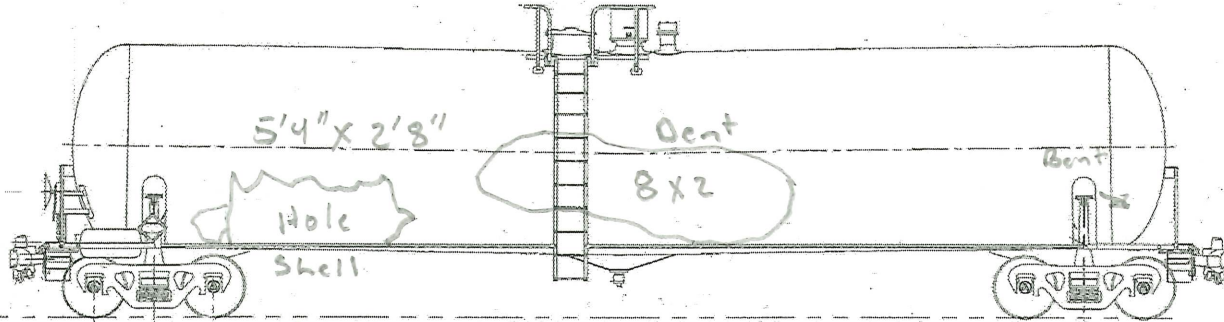

Builder Trinity

Built Date 12-4-15

DOT 117J100W

File# T19039

Loss of Commodity Yes / No All

Valves -Leaked / Sheared No

Top fittings MW OK MH OK

Bottom Outlet Leg OK Handle DT bent

Breach- Thermal Tear Yes Mech Tear Shell

Draft Sill A OK B OK

Head Shield A OK B Dent

PRD Functioned- Yes No

SKid OK

MT  
Empty

# Car Damage Report

3-12-15  
DGT-004  
Rev 4

Car Number CRDX 300073

Wreck index Number 19

Consist 57

Date of Derailment 1-8-22

Location OKLAHOMA TX

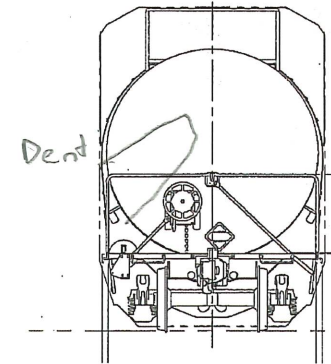
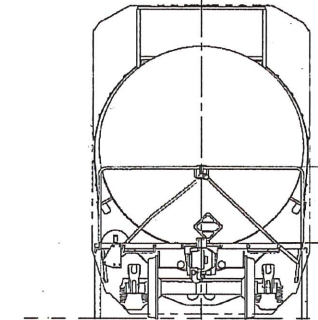
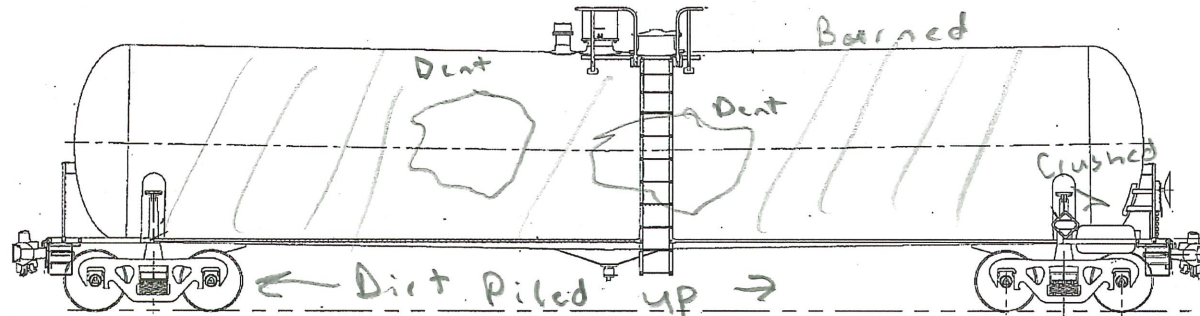
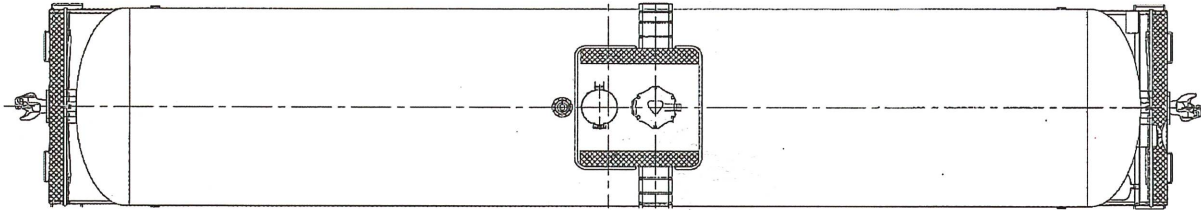
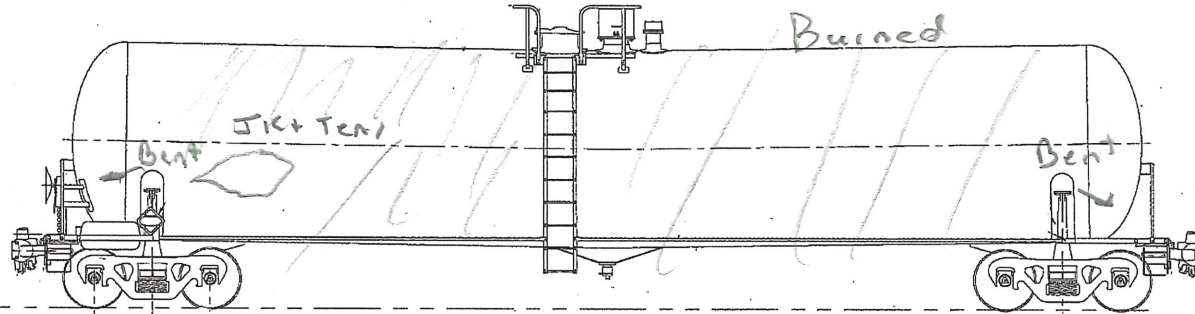

Builder Trinity

Built Date 12-25-15

DOT 117J100W

File# T15038

Loss of Commodity  Yes /  No

Valves -Leaked / Sheared

Top fittings MW OK MH OK

Bottom Outlet Leg Sheared Handle DT Torn off

Breach- Thermal Tear No Mech Tear No

Draft Sill A Buried B Twisted

Head Shield A OK B Dent

PRD Functioned-  Yes  No

Skid bent

Hold

Empty ?

Roll Inspected

A End Stub Sill

B End Stub sill + inboard - Head shield

# Car Damage Report

3-12-15  
DGT-004  
Rev 4

Car Number CRDX 300073

Wreck index Number \_\_\_\_\_ Consist 57

Inspection  
Date of Derailment 1-27-22 Additional

Location Oklahoma Tx

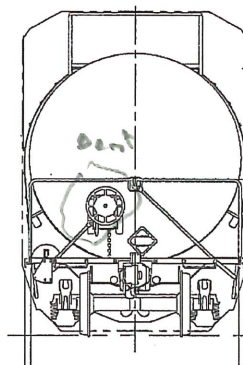
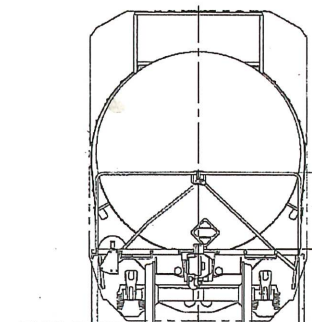
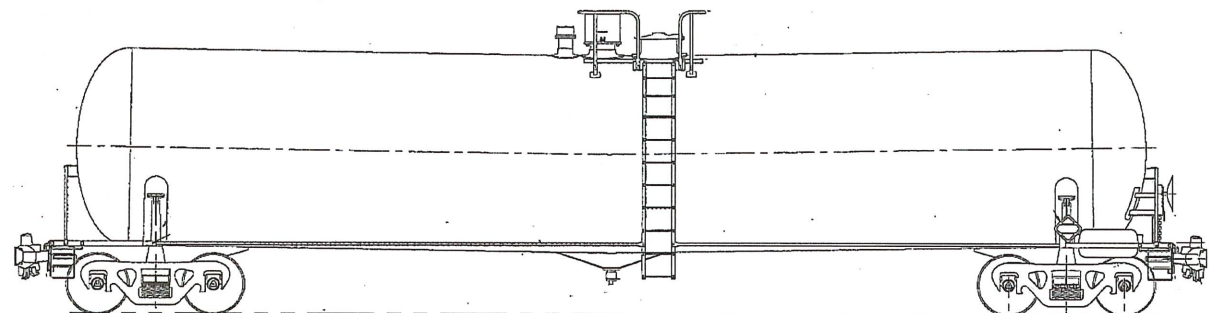
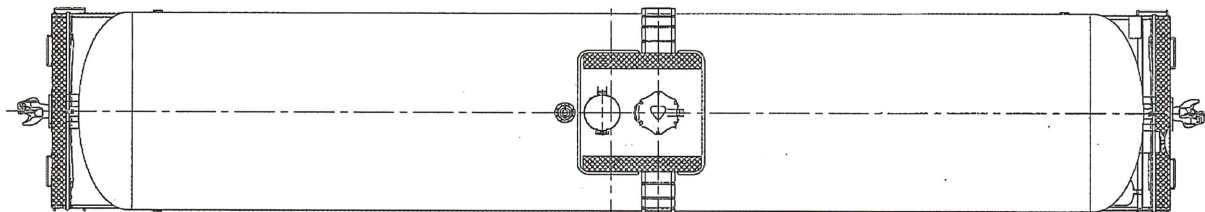
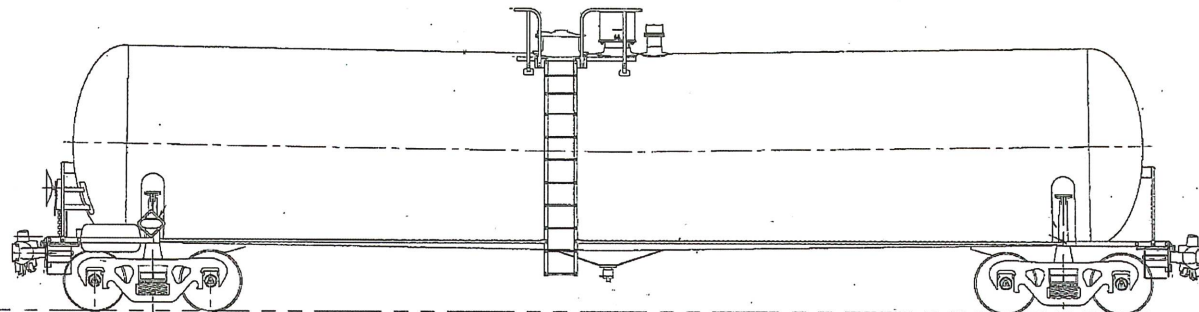

B head R-rod

Head Pad  
Head brace  
Welds OK  
3 PASSES

Pat B Advised Valve was opened by Emp. BOU opened in derailment?

Builder \_\_\_\_\_  
Built Date \_\_\_\_\_  
DOT \_\_\_\_\_  
File# \_\_\_\_\_  
Loss of Commodity Yes / No  
Valves -Leaked / Sheared

1 3/4"

Top fittings MW MH  
Bottom Outlet Leg Handle DT  
Breach- Thermal Tear Mech Tear  
Draft Sill A B  
Head Shield A B  
PRD Functioned- Yes No

# Car Damage Report

3-12-15  
DGT -004  
Rev 4

20

Car Number CRDX 3000 59

Wreck index Number 23 Consist 58

Date of Derailment 1-8-22

Location Oklahoma TX

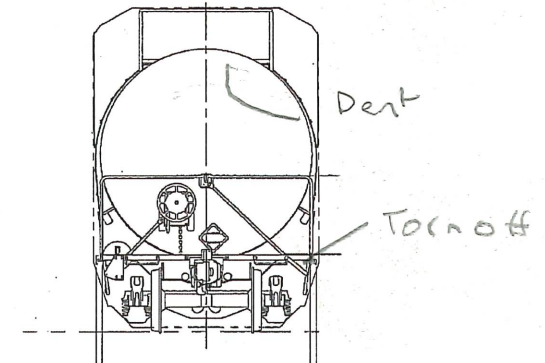
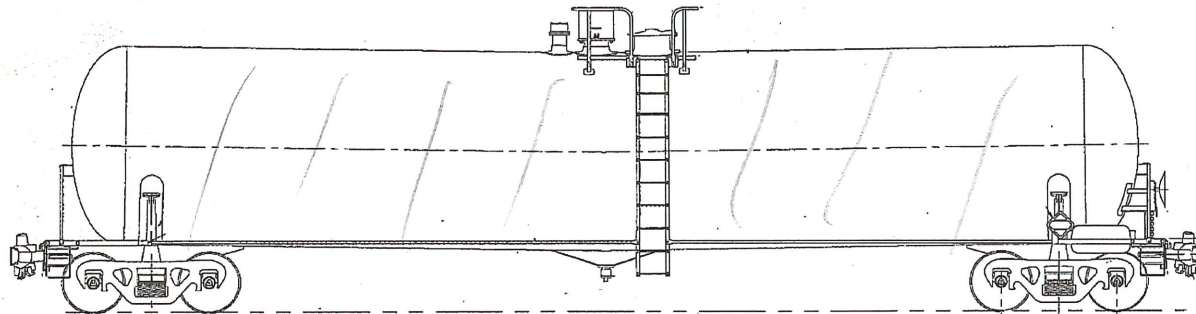
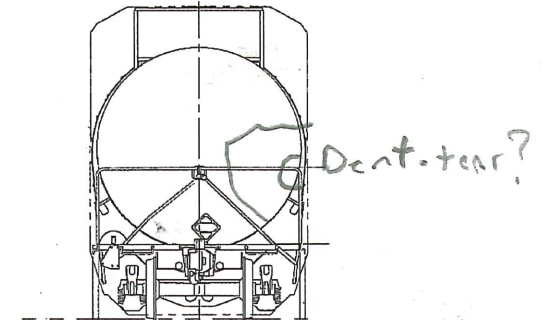
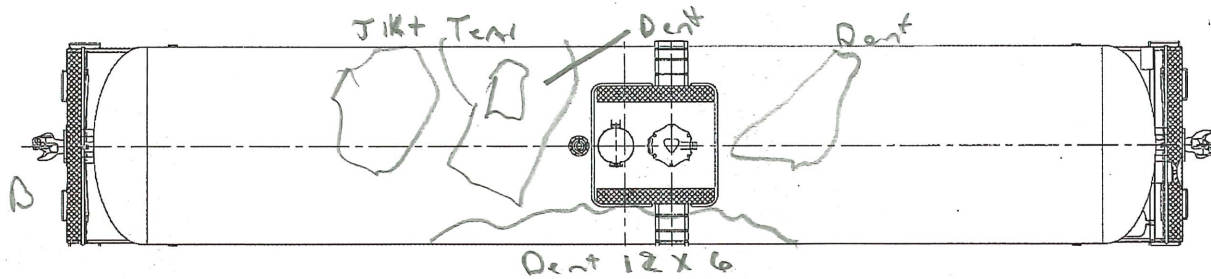
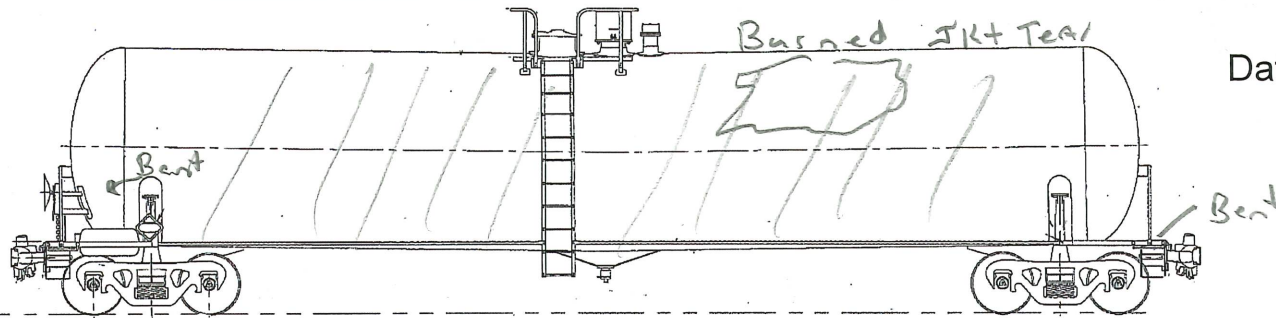

Builder Trinity  
 Built Date 11-26-15  
 DOT 1175100W  
 File# T15038  
 Loss of Commodity (Yes) / No  
 Valves -Leaked / Sheared  
BOV Dripping

Top fittings MW OK MH OK  
 Bottom Outlet Leg OK Handle DT Bent  
 Breach- Thermal Tear No Mech Tear No  
 Draft Sill A Bent Cplc Shear B OK  
 Head Shield A Dent B OK  
 PRD Functioned- (Yes) No  
SKid OK

1/3

# Car Damage Report

3-12-15  
DGT -004  
Rev 4

Car Number TILX 731429

Wreck index Number 15

Consist 59

Date of Derailment 1-8-22

Location OKlaunion Tx

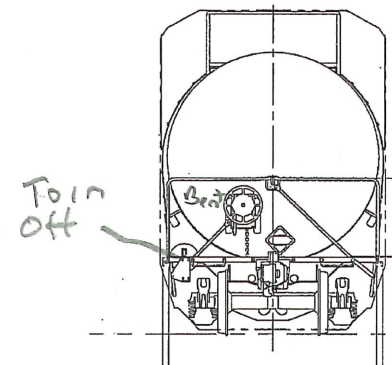
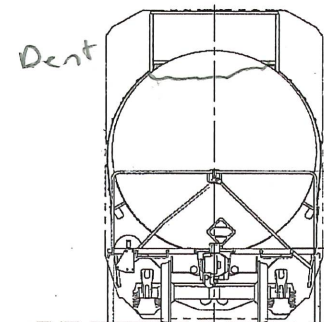
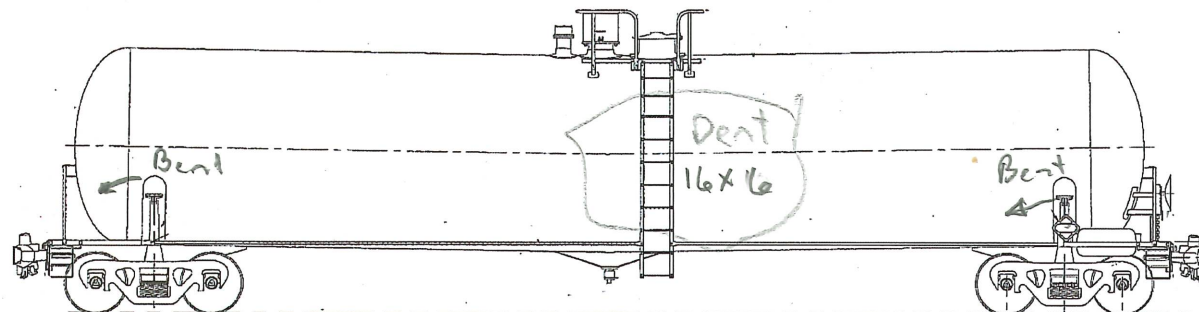
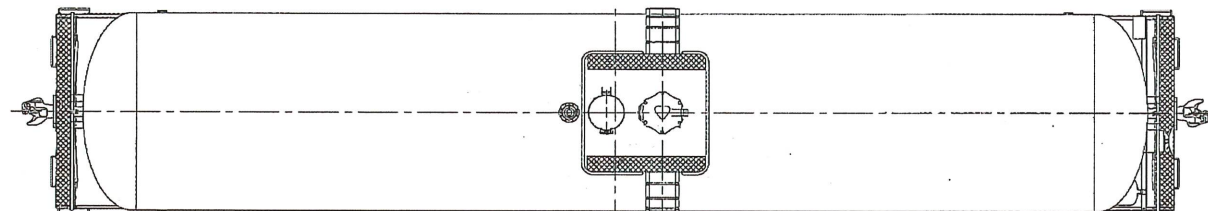
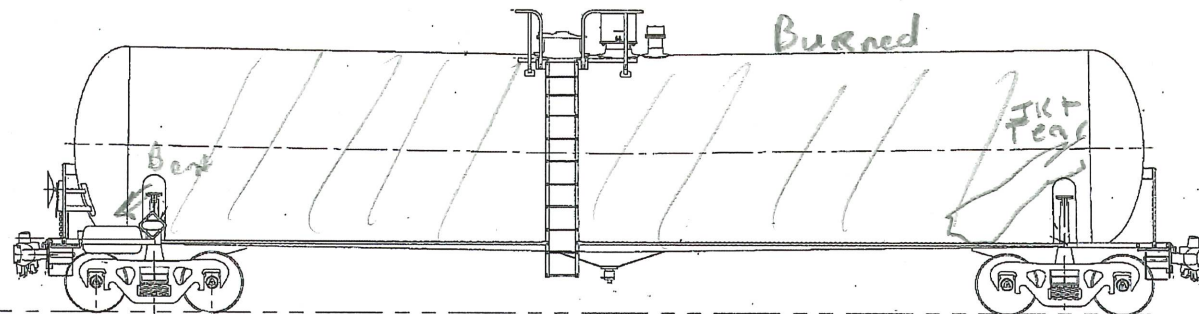

Builder Trinity

Built Date 11-11-20

DOT 117J100W

File# T19039

Loss of Commodity Yes / No

Valves -Leaked / Sheared No

Top fittings MW OK MH OK

Bottom Outlet Leg Sheared Handle DT torn off

Breach- Thermal Tear No Mech Tear No

Draft Sill A OK B OK

Head Shield A Dent B OK

PRD Functioned- Yes No

Skid Bent

# Car Damage Report

3-12-15  
DGT-004  
Rev 4

27

Car Number CRDX300056

Wreck index Number \_\_\_\_\_

Consist 60

Date of Derailment 1-8-22

Location OKlaunion TX

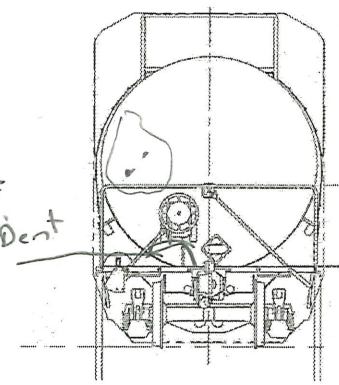
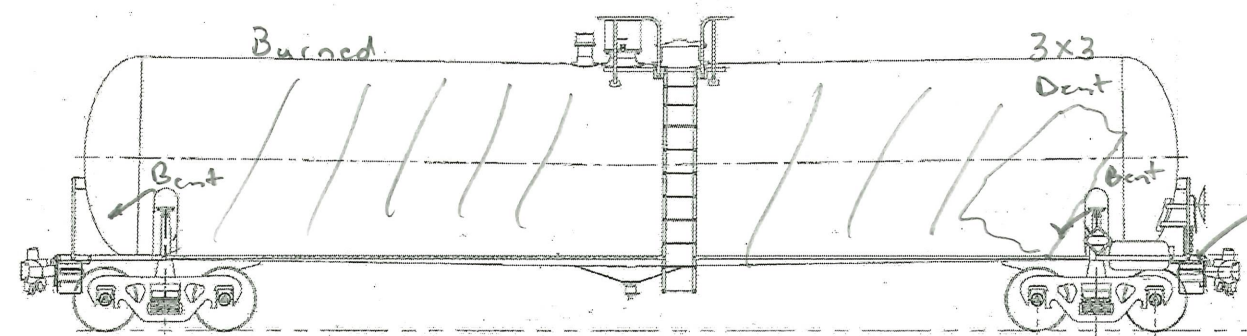
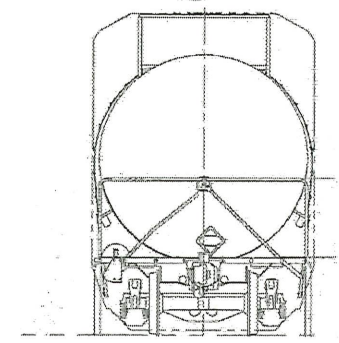
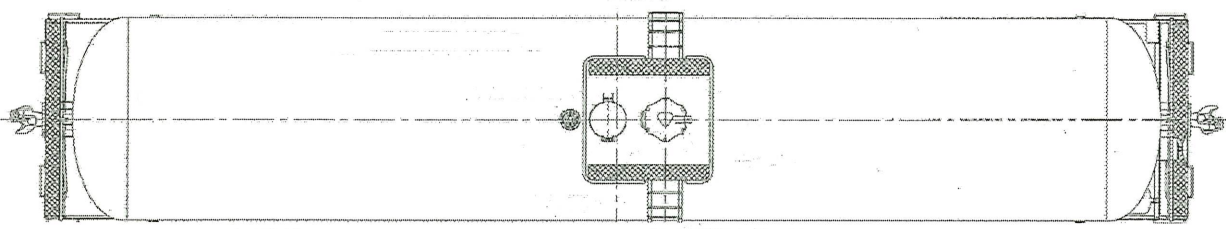
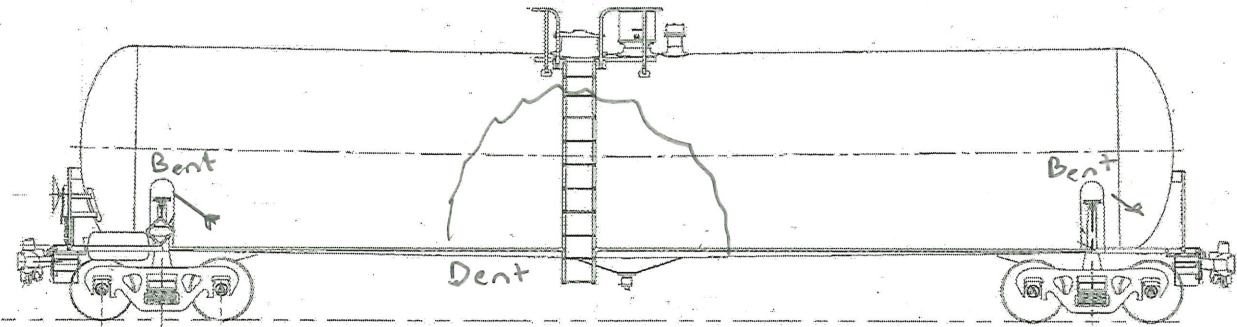

Builder Trinity  
 Built Date 12-7-15  
 DOT 117J100W  
 File# T19039  
 Loss of Commodity Yes / No  
 Valves -Leaked / Sheared No

Top fittings MW OK MH OK Dent  
 Bottom Outlet Leg 3 Buried Handle DT Bent  
 Breach- Thermal Tear No Mech Tear No  
 Draft Sill A Bent B Twisted  
 Head Shield A OK B Dent  
 PRD Functioned- Yes No  
 Skid buried

1/4  
 Hold  
 Roll Skid  
 Box?

# Car Damage Report

3-12-15  
DGT -004  
Rev 4

Car Number CRDX 300019

Wreck index Number 22

Consist 61

Date of Derailment 1-8-22

Location OKLA Union TX

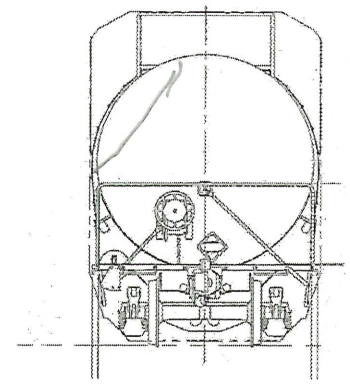
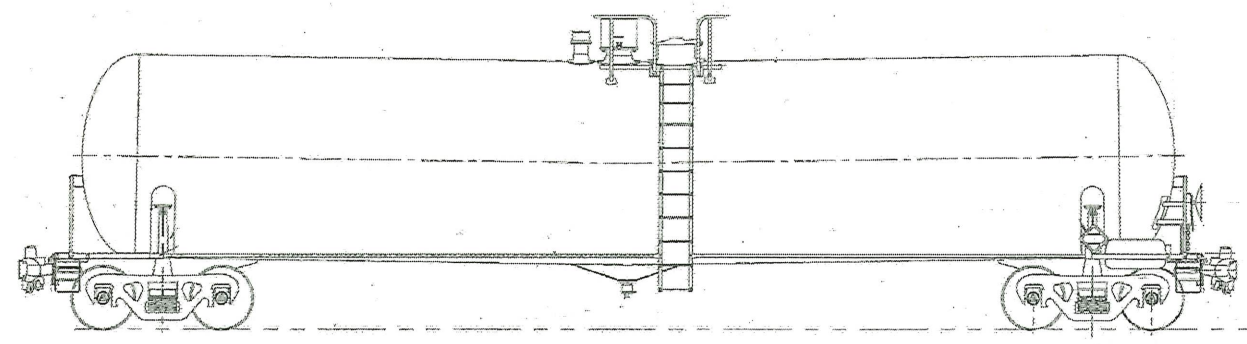
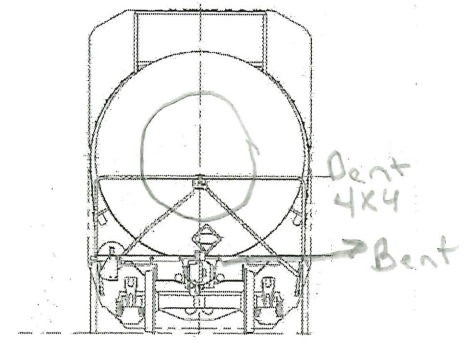
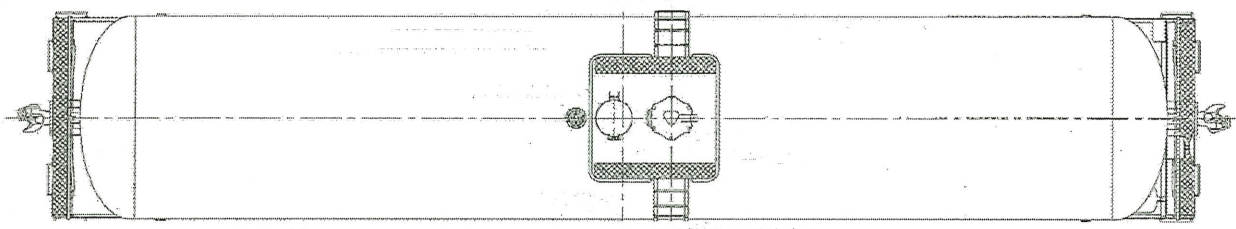
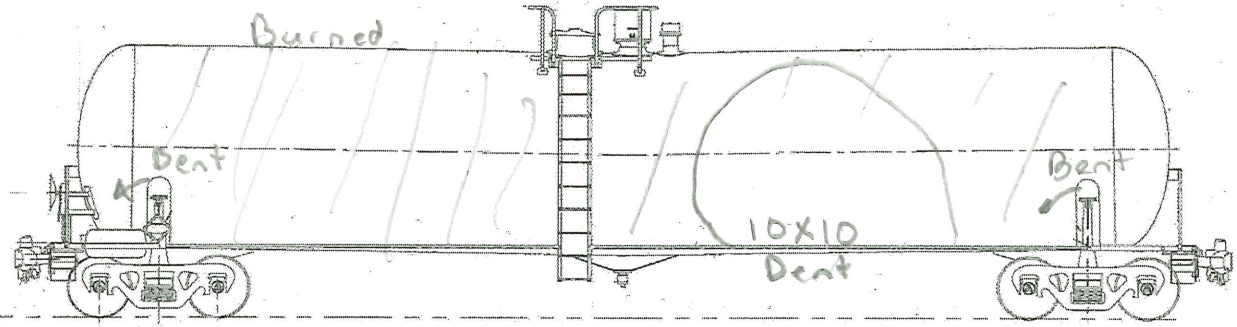

Builder Trinity

Built Date 11-5-15

DOT 117 J 100W

File# T19039

Loss of Commodity Yes / No BOV Leaking

Valves -Leaked / Sheared No

Top fittings MW OK MH OK

Bottom Outlet Leg OK Handle DT bent

Breach- Thermal Tear No Mech Tear No

Draft Sill A Bent B Bent

Head Shield A Dent B Dent

PRD Functioned- Yes No

Slid OK

1/2  
Hold  
A-End Stub S:11

Extinguished 330 1-12-22

Fire @ BOU

\* move Dirt inspect

# Car Damage Report

16

3-12-15  
DGT-004  
Rev 4

Car Number CRDX 300093

Wreck index Number 17

Consist 62

Date of Derailment 1-8-22

Location OKIN Union TX

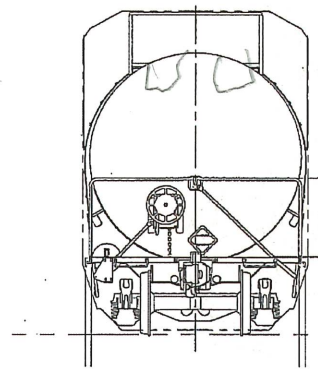
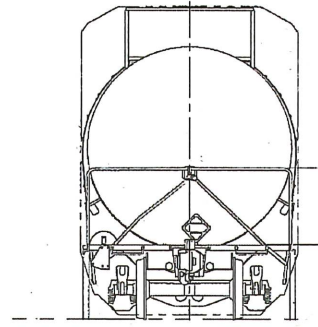
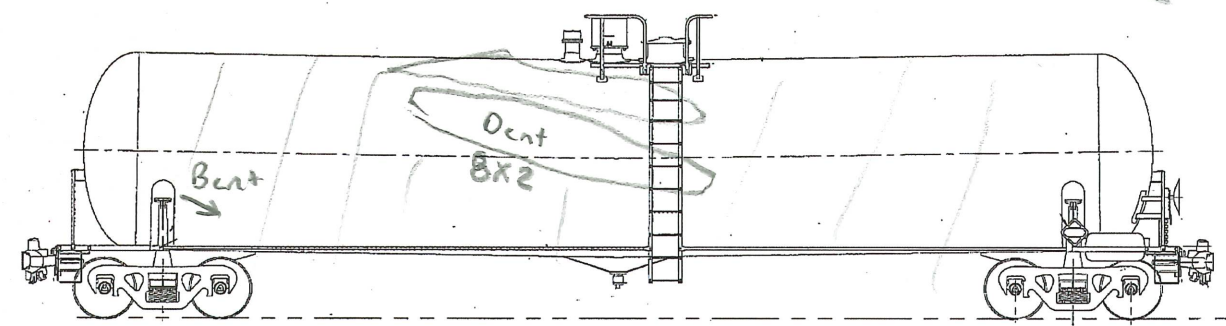
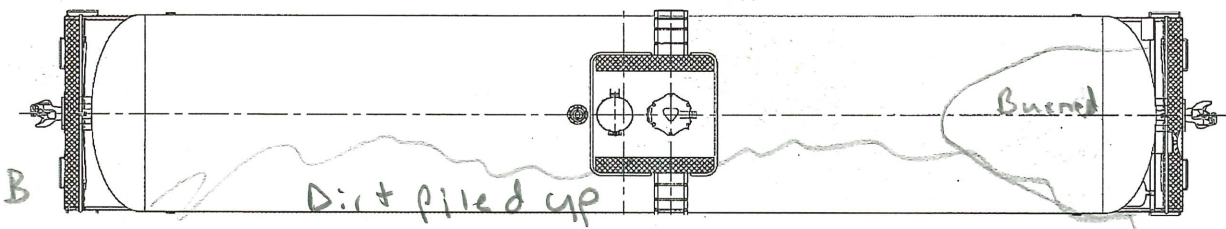
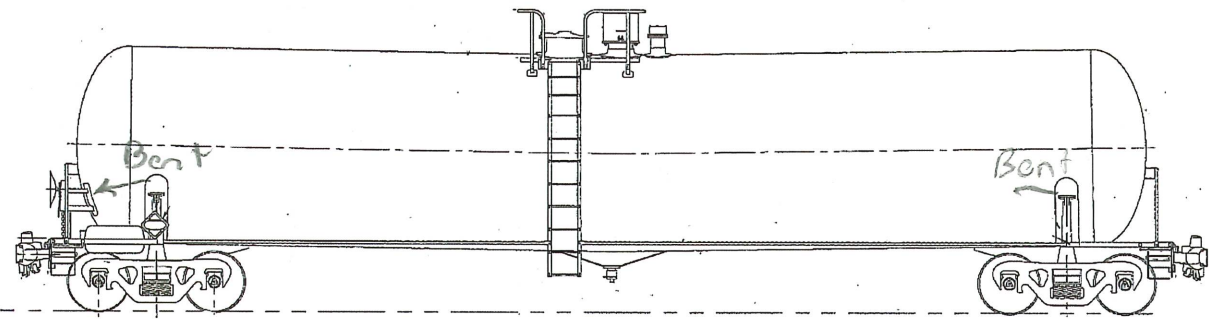

Builder Trinity

Built Date 11-26-15

DOT 1175100W

File# T15038

Loss of Commodity Yes / No

Valves -Leaked / Sheared No

on side Dirt Piled up

Top fittings MW OK MH OK

Bottom Outlet Leg Sheared Handle DT

Breach- Thermal Tear No Mech Tear No

Draft Sill A Bent B bent

Head Shield A B Bent

PRD Functioned- Yes No

Skid OK

Torn off

Hold  
inspect BR  
& BOU



# Car Damage Report

3-12-15  
DGT-004  
Rev 4

21

Hold  
A End  
Stub Sill + Pad

Car Number TILX 731751

Wreck index Number 24

Consist 63

Date of Derailment 1-8-22

Location OK Junction TX

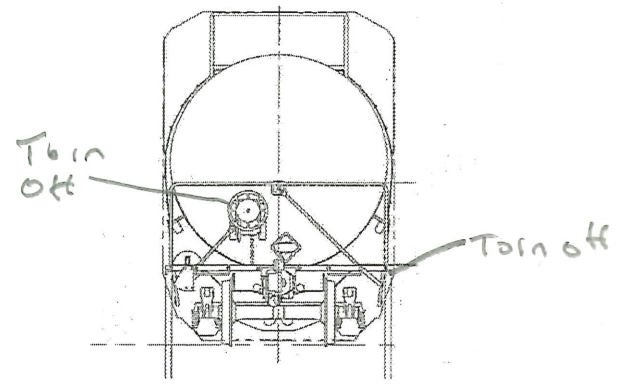
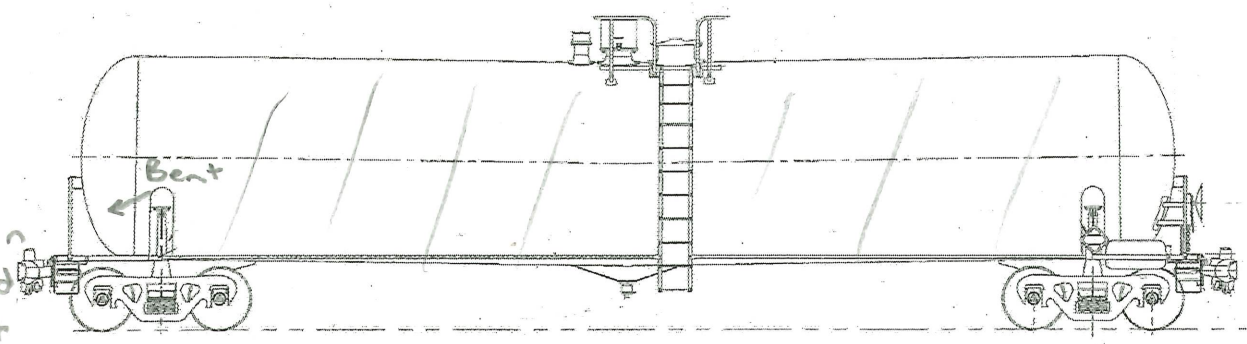
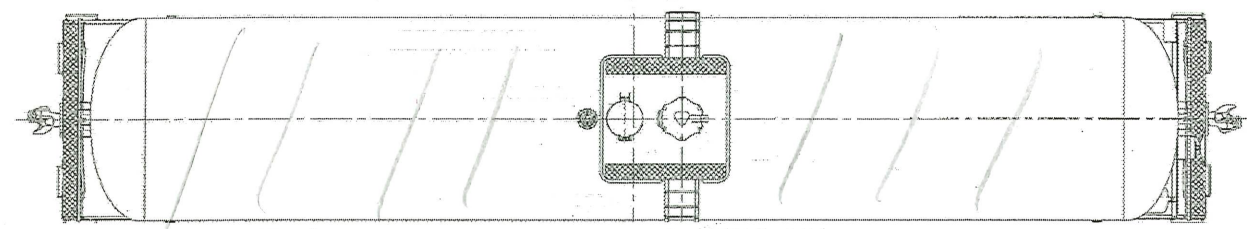
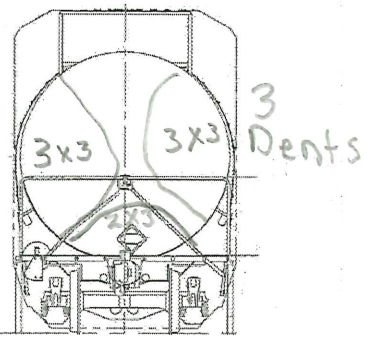
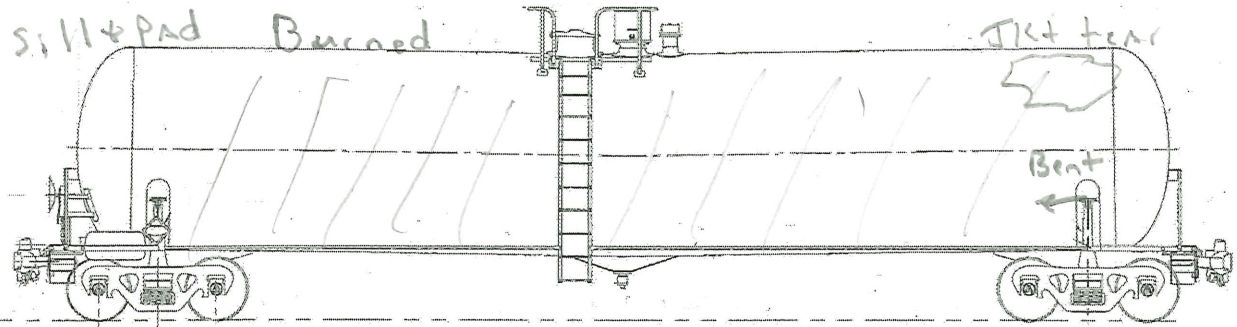

Hold  
HB torn  
from pad  
Top of  
cut out  
torn tank shell  
A+top

Builder Trinity  
Built Date 10-21-20  
DOT 117J10AW  
File# T19039  
Loss of Commodity Yes / No  
Valves -Leaked / Sheared No

HB torn from  
PAD

Top fittings MW OK MH OK  
Bottom Outlet Leg OK Handle DT bent  
Breach- Thermal Tear No Mech Tear Yes @ A and HB  
Draft Sill A torn open B OK Cplr head sheared  
Head Shield A 2 Dents B OK  
PRD Functioned- Yes No  
SKID OK

# Car Damage Report

3-12-15  
DGT-004  
Rev 4

Car Number TILX 731751

Wreck index Number \_\_\_\_\_ Consist 63

Inspection  
Date of Derailment 1-27-22 Additional \_\_\_\_\_

Location OKlaunion

Section  
of A  
End Stub  
Sill + Head Pad

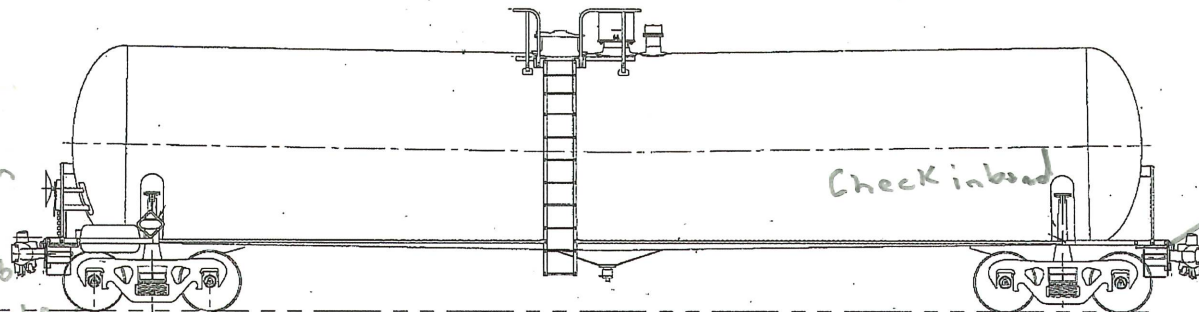

Pealed open  
Top turn open  
Left side  
Peel back  
65X88  
12" over  
Dent

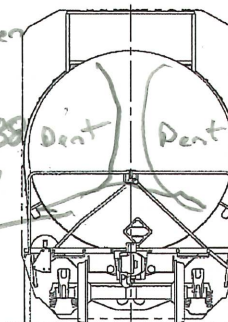

69' x 70"  
60" x 8" Deep  
32 3/4" vert  
to Head Pad  
tear

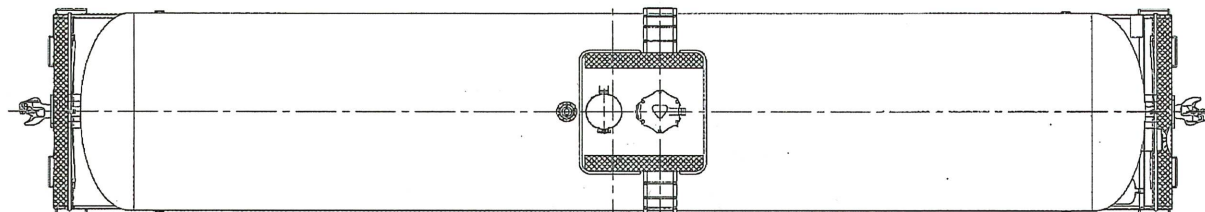

A End  
Head Pad  
Pulled from  
HB 6"

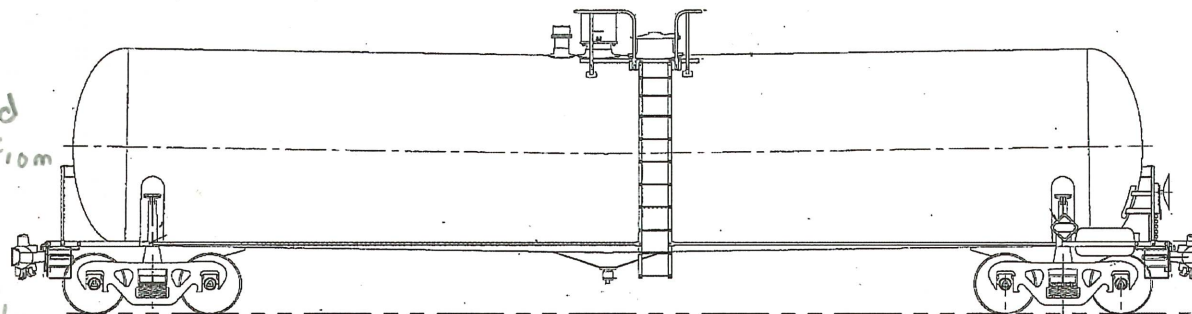

Head Pad  
webs 1/2" 3PASS

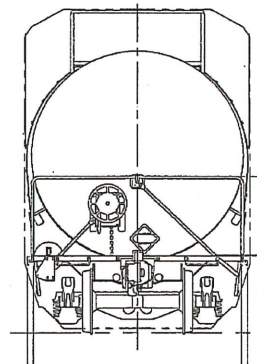

Top of HB 4"  
to top of Pad

Builder \_\_\_\_\_  
Built Date \_\_\_\_\_  
DOT \_\_\_\_\_  
File# \_\_\_\_\_  
Loss of Commodity Yes / No  
Valves -Leaked / Sheared \_\_\_\_\_

Top fittings MW \_\_\_\_\_ MH \_\_\_\_\_  
Bottom Outlet Leg \_\_\_\_\_ Handle \_\_\_\_\_ DT \_\_\_\_\_  
Breach- Thermal Tear \_\_\_\_\_ Mech Tear \_\_\_\_\_  
Draft Sill A \_\_\_\_\_ B \_\_\_\_\_  
Head Shield A \_\_\_\_\_ B \_\_\_\_\_  
PRD Functioned- Yes \_\_\_\_\_ No \_\_\_\_\_

# Car Damage Report

3-12-15  
DGT-004  
Rev 4

22

Car Number TILX 731741 Wreck index Number 25 Consist 64

Date of Derailment 1-8-22

Location GICLA Union TX

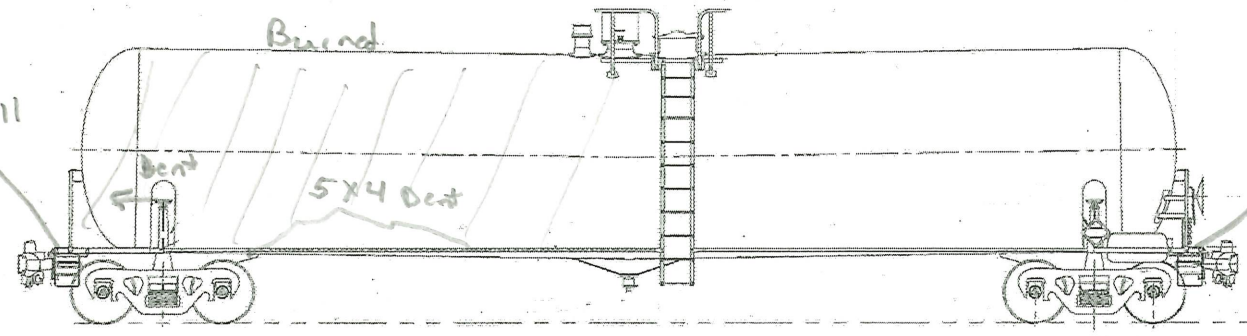
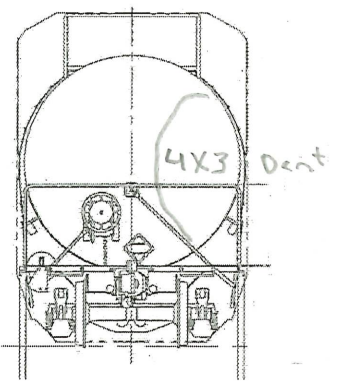
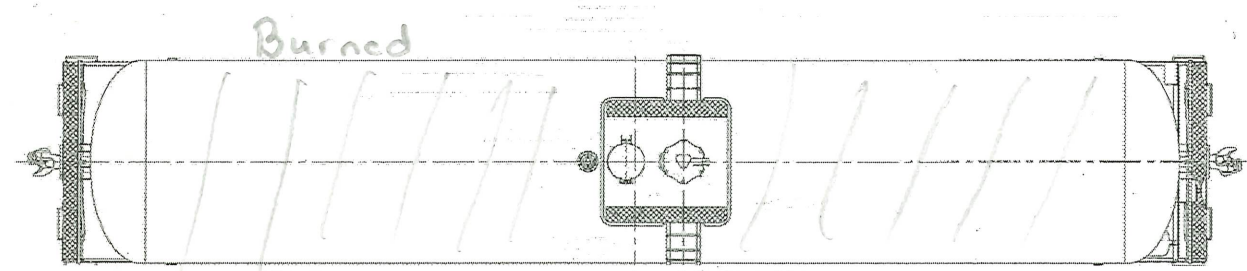
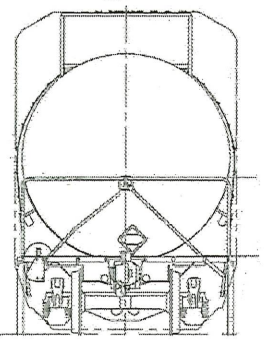
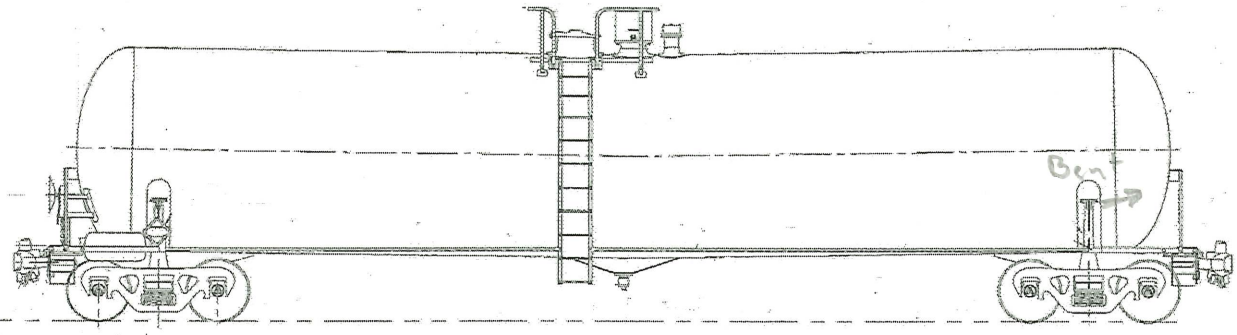

Builder Trinity  
Built Date 10-21-20  
DOT 117J160W  
File# T19039  
Loss of Commodity Yes / No  
Valves -Leaked / Sheared No

Top fittings MW OK MH OK  
Bottom Outlet Leg Sheared Handle DT OK  
Breach- Thermal Tear No Mech Tear No  
Draft Sill A torn off @ HB B OK Cplr Sheared off  
Head Shield A OK B OK  
PRD Functioned- Yes No  
SKD OK

weld to sill

Stub Sill  
Torn  
Off  
@ HB

1/4

Hold  
Stub Sill @ HB

# Car Damage Report

3-12-15  
DGT -004  
Rev 4

②

Car Number T 1LX 731741

Wreck index Number \_\_\_\_\_

Consist 64

Inspection  
Date of Derailment 1-27-22 Additional \_\_\_\_\_

Location DKlaunion Tx mm  
Head Pad 10-12  
SARS 10-12  
Cut out 5mm  
Inband  
10-12 outband

Loops →

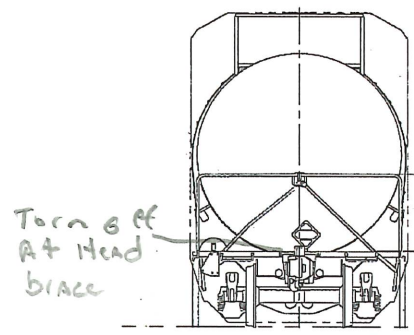
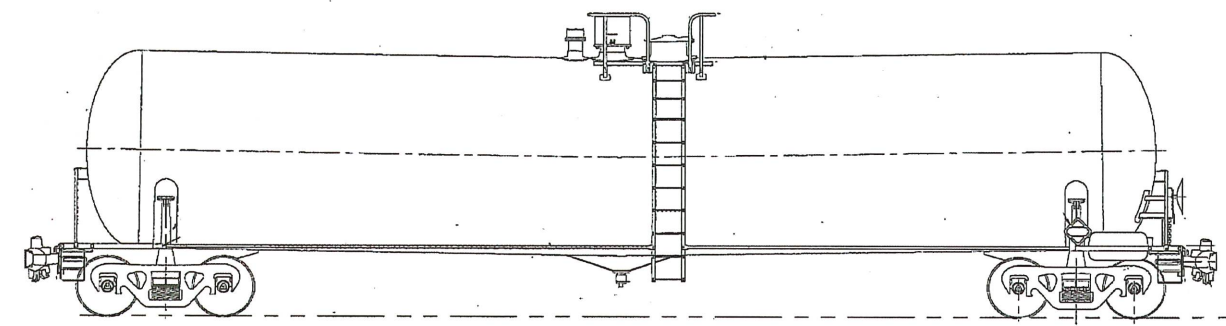
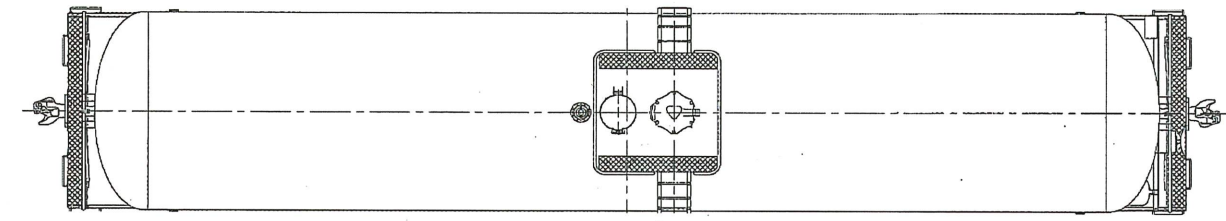
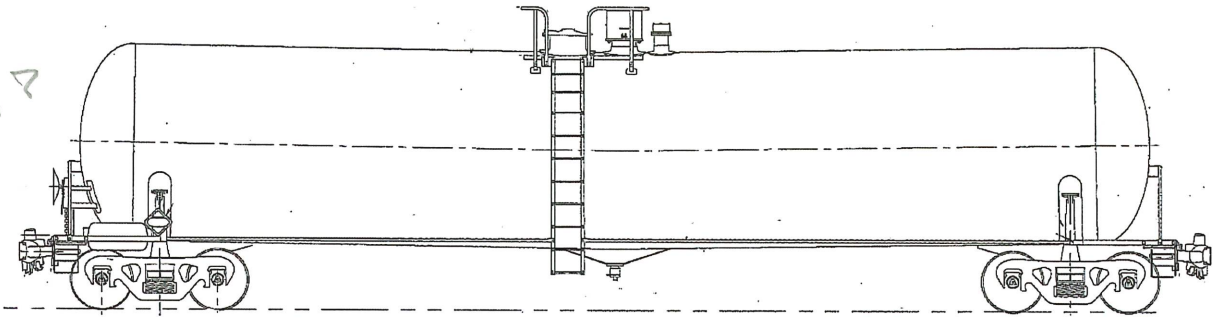

Turn off  
AT Head  
brace

Sill bent to AL  
Side  
Stub Sill torn  
off @ HB  
Head Pad has  
2" crack AR  
Cut out

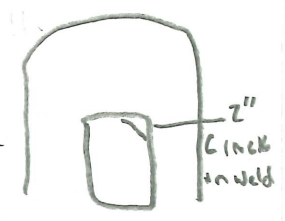
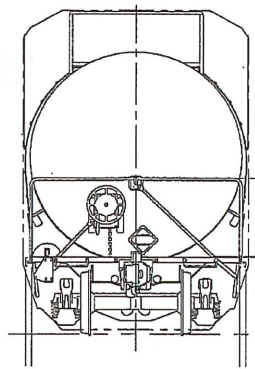

Builder \_\_\_\_\_  
Built Date \_\_\_\_\_  
DOT \_\_\_\_\_  
File# \_\_\_\_\_  
Loss of Commodity Yes / No  
Valves -Leaked / Sheared

Top fittings MW MH  
Bottom Outlet Leg Handle DT  
Breach- Thermal Tear \_\_\_\_\_ Mech Tear \_\_\_\_\_  
Draft Sill A B  
Head Shield A B  
PRD Functioned- Yes No

# Car Damage Report

3-12-15  
DGT -004  
Rev 4

Car Number TILX731758

Wreck index Number 27

Consist 65

Date of Derailment 1-8-22

Location Dickinson TX

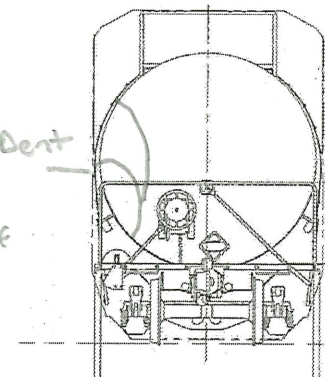
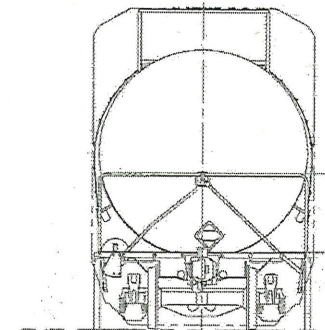
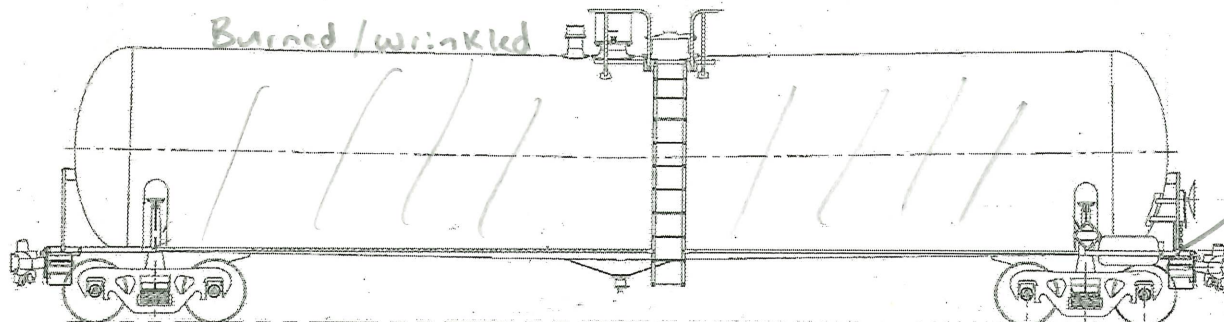
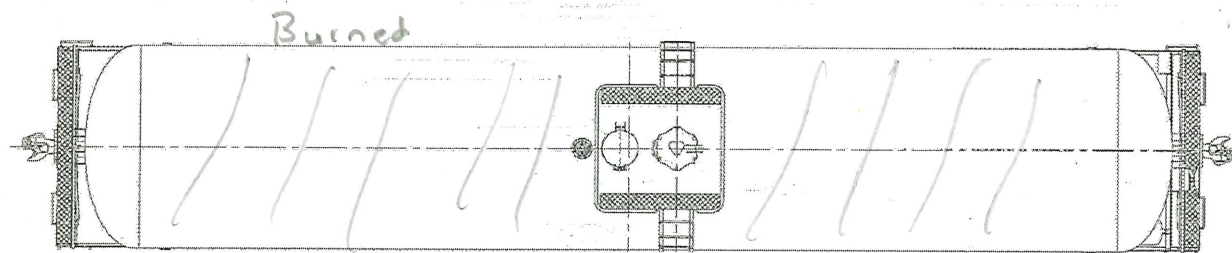
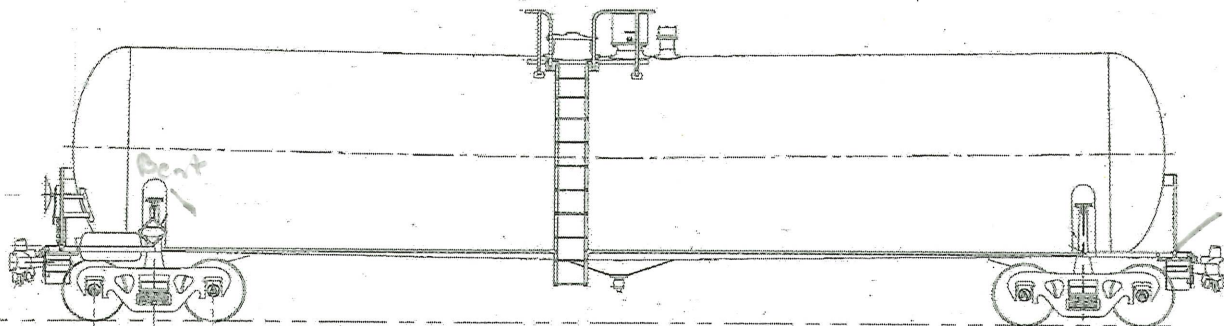

Builder Trinity  
 Built Date 10-21-20  
 DOT 1175100w  
 File# T19039  
 Loss of Commodity Yes / No  
 Valves -Leaked / Sheared No

Top fittings MW OK MH OK  
 Bottom Outlet Leg OK Handle DT OK  
 Breach- Thermal Tear No Mech Tear No  
 Draft Sill A twisted B OK Coll Sheared  
 Head Shield A OK B Dent  
 PRD Functioned- Yes No  
 Skid OK

Hold  
 A End stub Sill

# Car Damage Report

③

3-12-15  
DGT -004  
Rev 4

Car Number TILX 731758

Wreck index Number \_\_\_\_\_

Consist 605

Date of Derailment <sup>Inspection</sup> 1-27-22 Additional \_\_\_\_\_

Location DKlaunion Tx

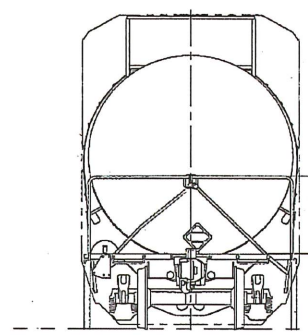
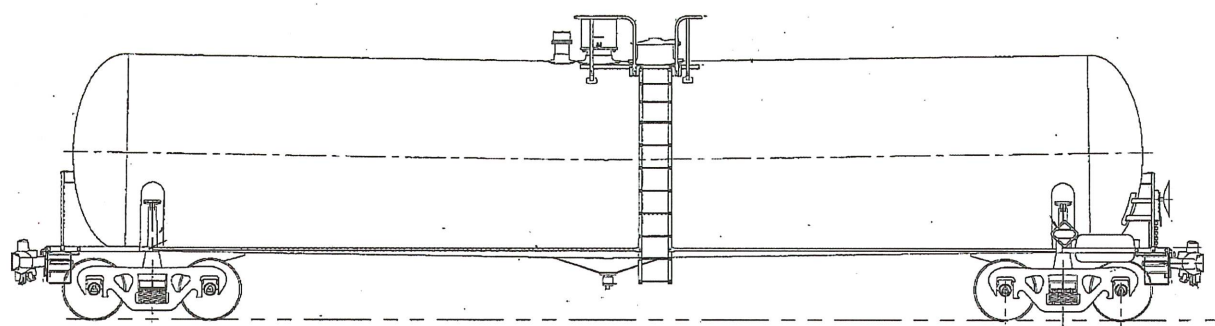
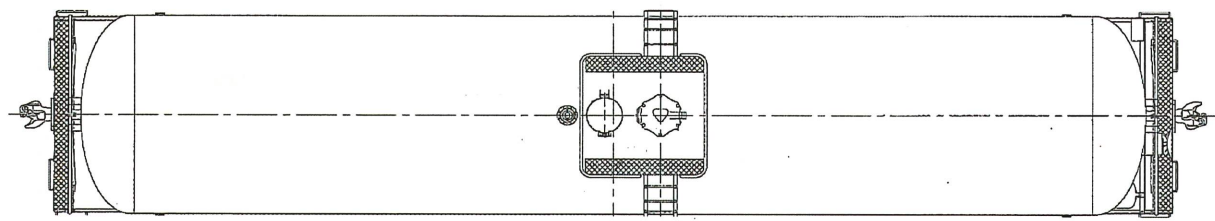
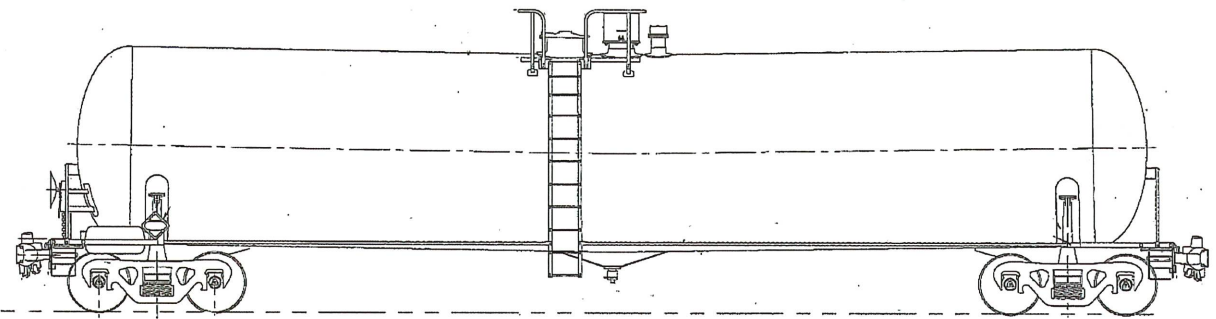

A End head  
Sill twisted  
to right side  
  
No CRACK

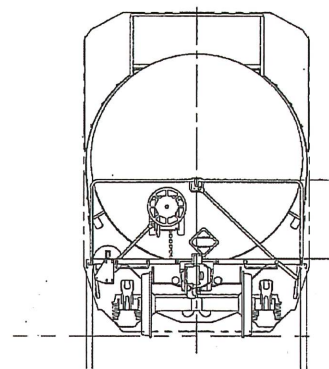

Builder \_\_\_\_\_  
Built Date \_\_\_\_\_  
DOT \_\_\_\_\_  
File# \_\_\_\_\_  
Loss of Commodity Yes / No  
Valves -Leaked / Sheared \_\_\_\_\_

Top fittings MW \_\_\_\_\_ MH \_\_\_\_\_  
Bottom Outlet Leg \_\_\_\_\_ Handle \_\_\_\_\_ DT \_\_\_\_\_  
Breach- Thermal Tear \_\_\_\_\_ Mech Tear \_\_\_\_\_  
Draft Sill A \_\_\_\_\_ B \_\_\_\_\_  
Head Shield A \_\_\_\_\_ B \_\_\_\_\_  
PRD Functioned- Yes \_\_\_\_\_ No \_\_\_\_\_

# Car Damage Report

3-12-15  
DGT -004  
Rev 4

29

Car Number TILX 731762

Wreck index Number 28

Consist 66

Date of Derailment 1-8-22

Location Oklaunion TX  
Placed 1987 3

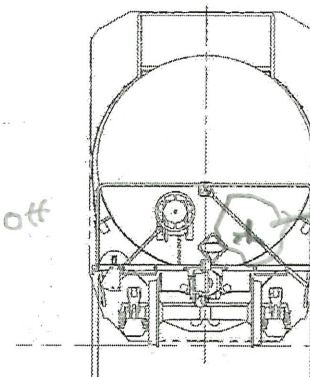
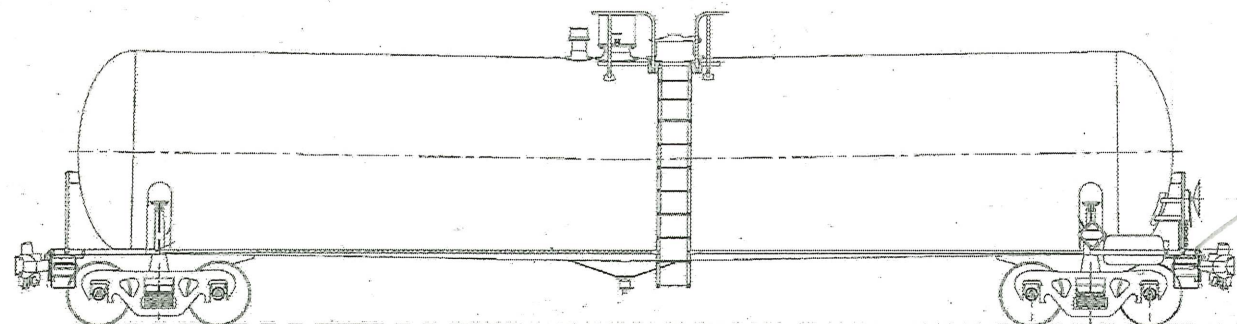
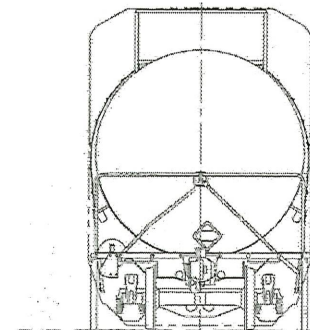
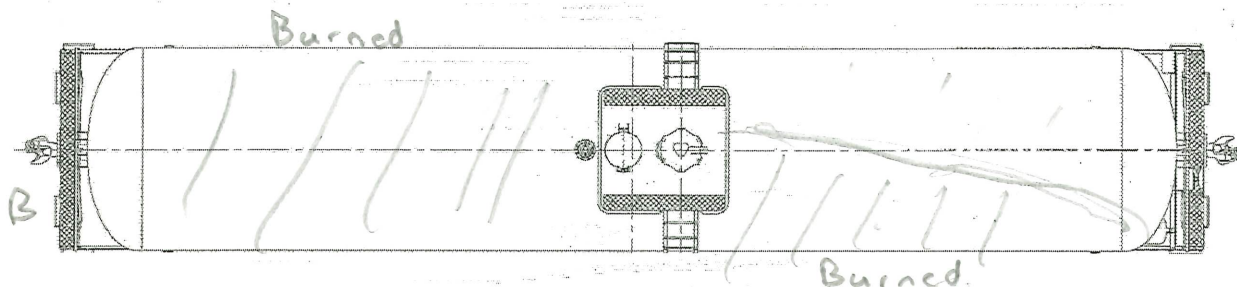
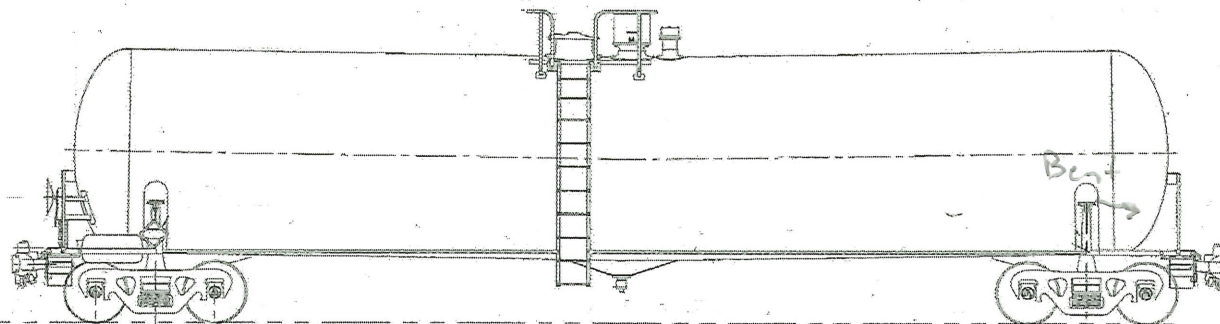

Builder Trinity  
Built Date 10-21-20  
DOT 117J100W  
File# T19039  
Loss of Commodity Yes / No  
Valves -Leaked / Sheared

Top fittings MW OK MH OK  
Bottom Outlet Leg OK Handle DT Bent  
Breach- Thermal Tear No Mech Tear Yes Head + shield  
Draft Sill A Bent torn B Bent  
Head Shield A OK B Punctured  
PRD Functioned- Yes No  
SKid OK

Hold stub B / Head shield / Hole

4

# Car Damage Report

3-12-15  
DGT -004  
Rev 4

Car Number TILX 731762

Wreck index Number \_\_\_\_\_

Consist 66

Date of Derailment 1-27-22 <sup>Inspection</sup> Additional

Location OKIA Union Tx

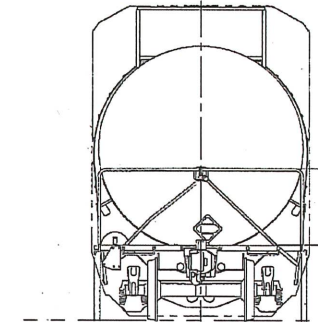
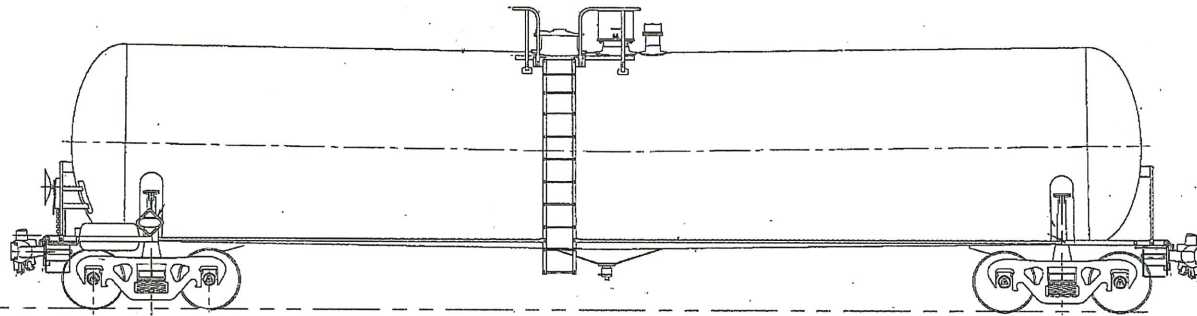

Crack in  
4 1/2" weld  
OK

2) (1)NTSB (1)Trin  
3X3 Coupons  
Removed  
for testing  
A  
End

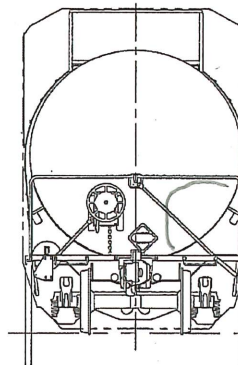
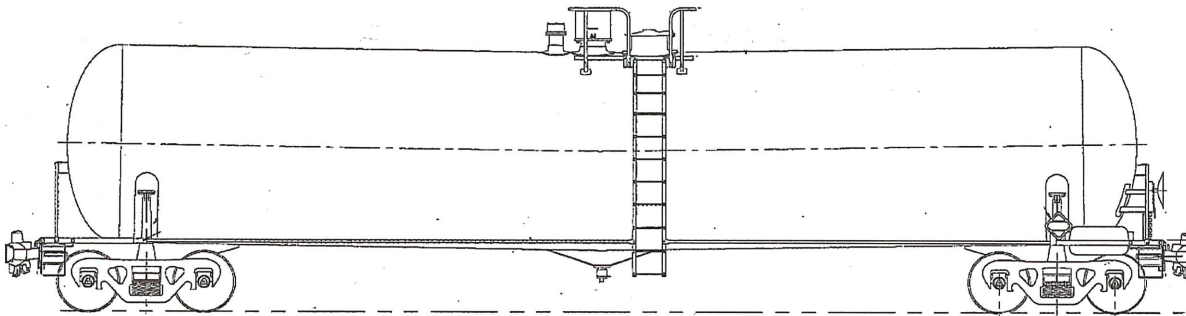
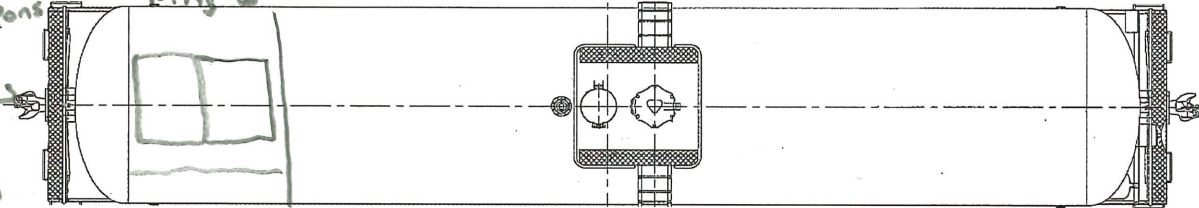

B head  
Dent 36" x 39"  
Puncture 6"  
16" from bottom

Builder \_\_\_\_\_  
Built Date \_\_\_\_\_  
DOT \_\_\_\_\_  
File# \_\_\_\_\_  
Loss of Commodity Yes / No  
Valves -Leaked / Sheared

Top fittings MW MH  
Bottom Outlet Leg Handle DT  
Breach- Thermal Tear          Mech Tear  
Draft Sill A B  
Head Shield A B  
PRD Functioned- Yes No

\* All valves removed for testing - Sent to Trin Saginaw



# Car Damage Report

3-12-15 37  
 DGT-004 Vernon  
 Rev 4

Car Number TILX 731744

Wreck index Number NA Consist 67

Date of Derailment 1-8-22

Location OKlaunion TX

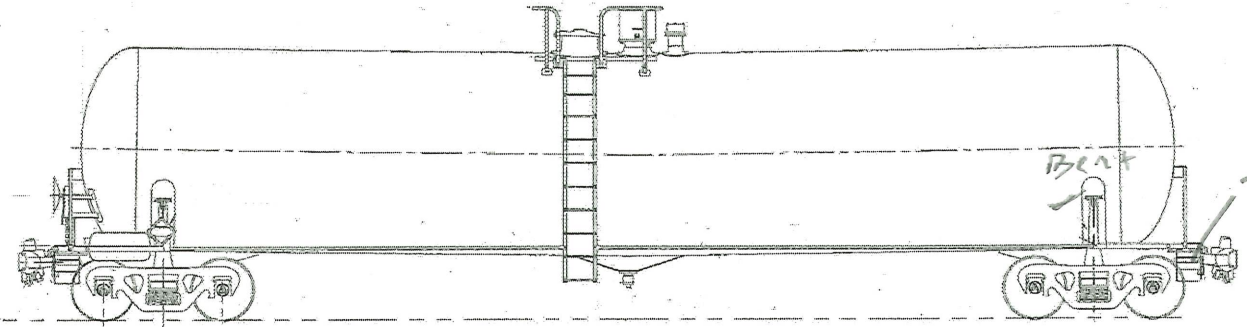

Twisted  
Coupler  
Sheared

Platform  
missing

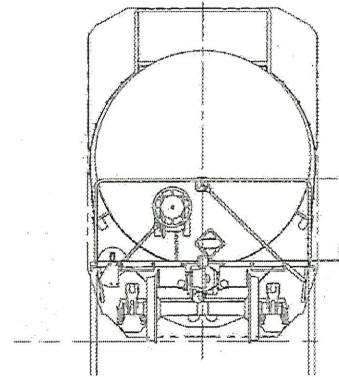
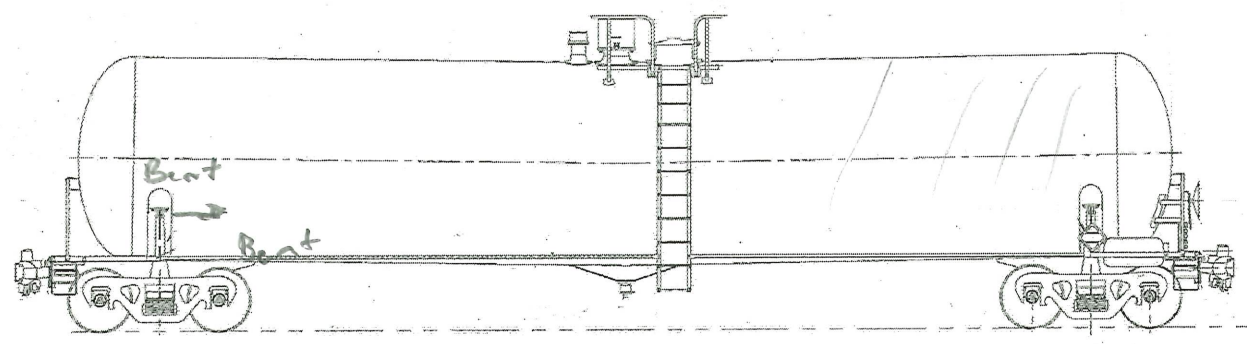
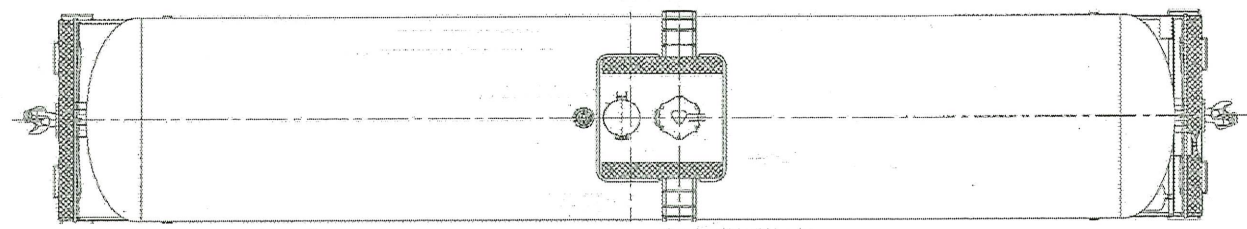
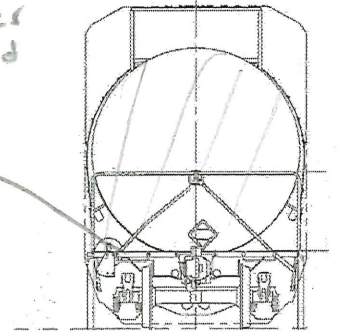

Builder Trinity  
 Built Date 10-30-20  
 DOT 1175100W  
 File# T19039  
 Loss of Commodity Yes / No  
 Valves -Leaked / Sheared No

Top fittings MW OK MH OK  
 Bottom Outlet Leg OK Handle DT OK  
 Breach- Thermal Tear No Mech Tear No  
 Draft Sill A Twisted B OK  
 Head Shield A OK B OK  
 PRD Functioned- Yes No

Coupler sheared

# Car Damage Report

3-12-15  
DGT-004 Vernon  
Rev 4

32

Car Number CRDX 3000 55 Wreck index Number NA Consist 68

Date of Derailment 1-9-22

Location OKIA Union Tx  
Placard 1987 3 Flammable

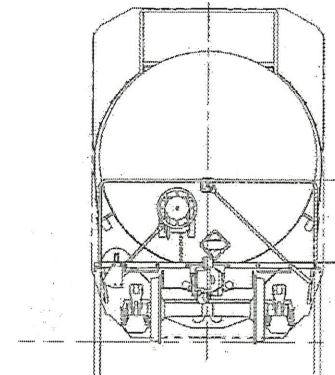
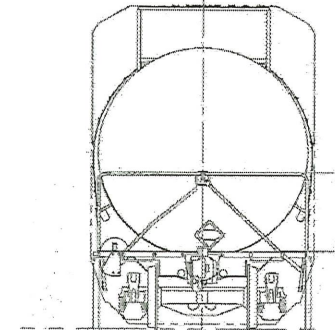
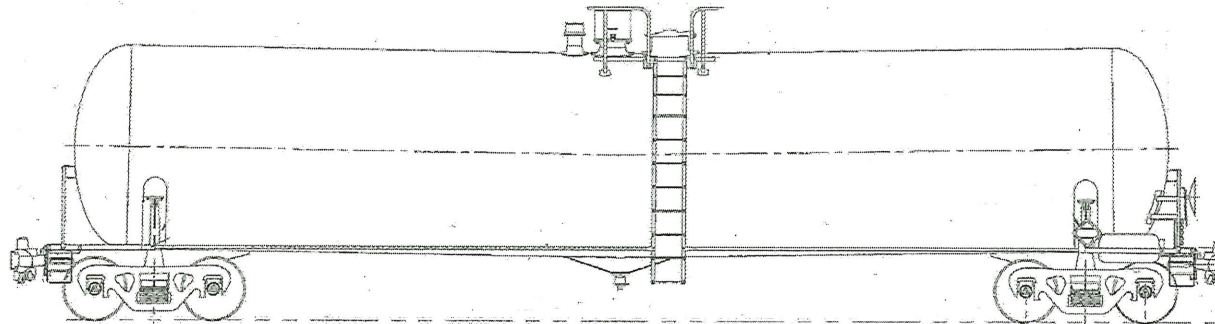
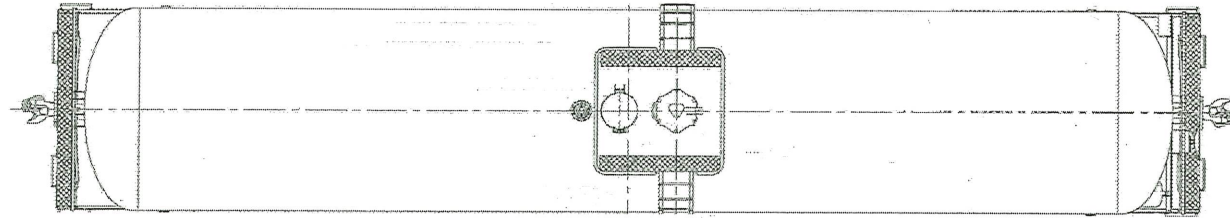
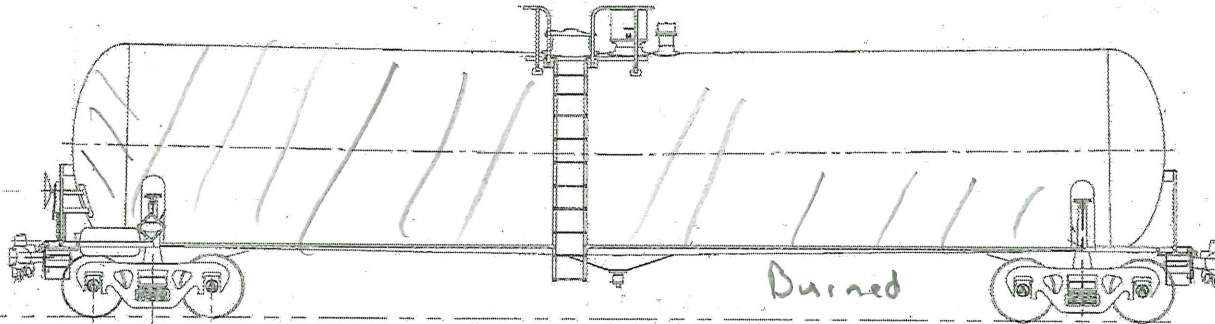

Builder Trinity  
Built Date 11-26-15  
DOT 117J100W  
File# T15038  
Loss of Commodity Yes / No  
Valves -Leaked / Sheared No

Top fittings MW OK MH OK  
Bottom Outlet Leg OK Handle DT OK  
Breach- Thermal Tear No Mech Tear No  
Draft Sill A OK B OK  
Head Shield A OK B OK  
PRD Functioned- Yes No

Burned  
Brake hoses  
Valves  
Bench  
Adaptors etc

# Car Damage Report

3-12-15 33  
DGT-004 Vernon  
Rev 4

Car Number CRDX 300072

Wreck index Number NA

Consist 69

Date of Derailment 1-8-22

Location OKIA Union TX

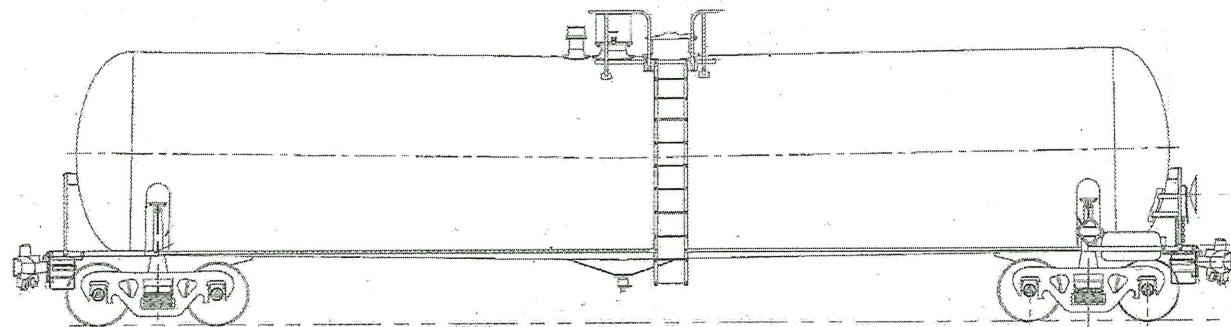
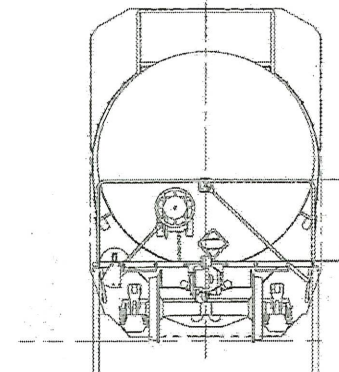
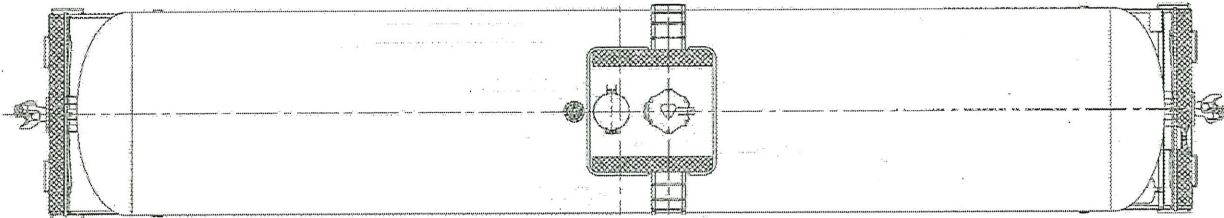
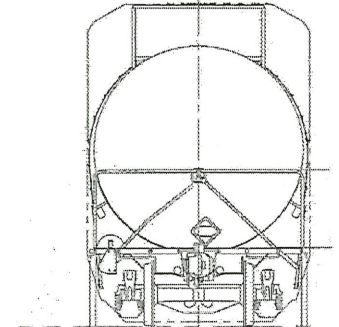
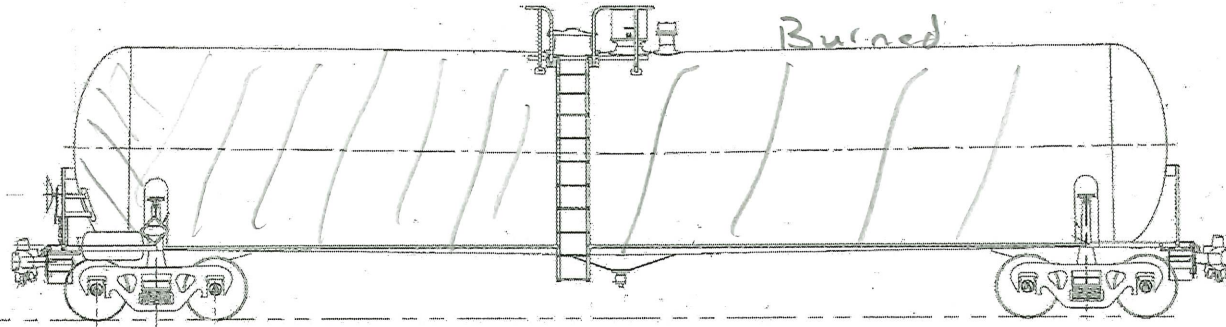

Builder Trinity  
Built Date 11-27-15  
DOT 117J100W  
File# T15038  
Loss of Commodity Yes / No  
Valves -Leaked / Sheared No

Top fittings MW OK MH OK  
Bottom Outlet Leg DK Handle DT OK  
Breach- Thermal Tear No Mech Tear No  
Draft Sill A OK B OK  
Head Shield A OK B OK  
PRD Functioned- Yes No

# Car Damage Report

3-12-15  
DGT-004  
Rev 4  
34  
Vernon

Car Number CRDX306101

Wreck index Number NA

Consist 70

Date of Derailment 1-8-22

Location Oklahoma Tx

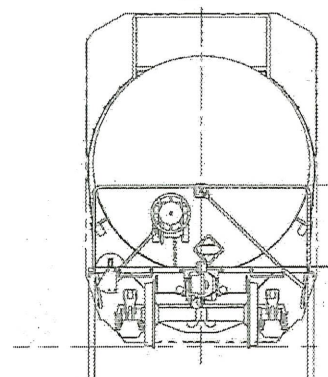
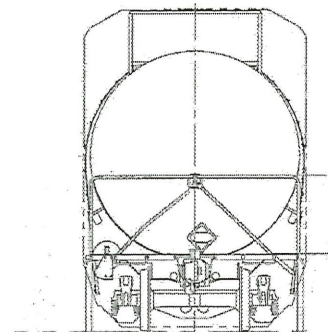
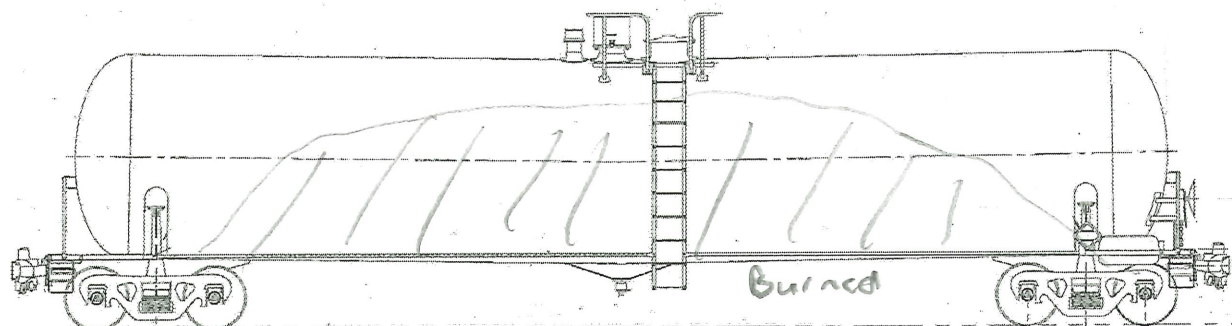
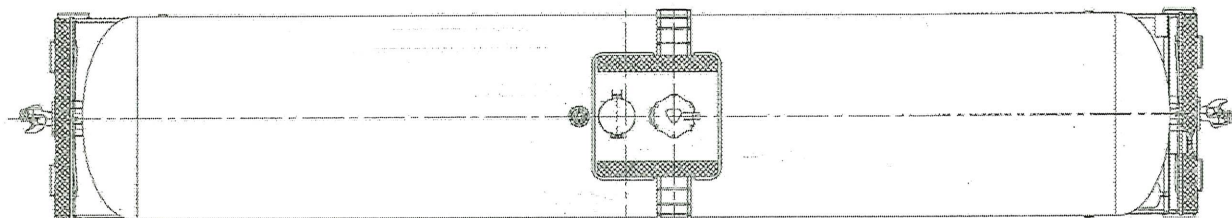
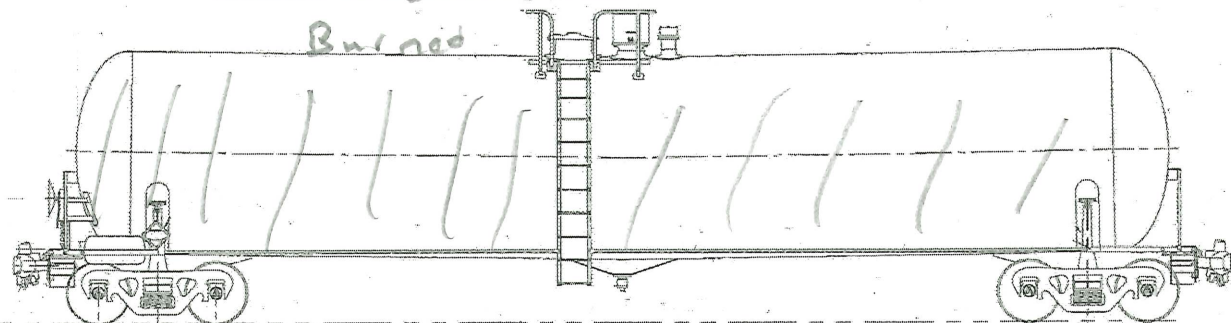

All Brake  
Components  
melted  
Bearings + Axle

Builder Trinity

Built Date 11-25-15

DOT 117J100W

File# T15038

Loss of Commodity Yes / No

Valves -Leaked / Sheared No

Top fittings MW OK MH OK

Bottom Outlet Leg OK Handle - DT OK

Breach- Thermal Tear No Mech Tear No

Draft Sill A OK B OK

Head Shield A OK B OK

PRD Functioned- Yes No

# Car Damage Report

3-12-15 <sup>35</sup>  
DGT-004 <sup>Vernon</sup>  
Rev 4

Car Number TLLX 731458

Wreck index Number NA Consist 71

Date of Derailment 1-8-22

Location OK Junction TX

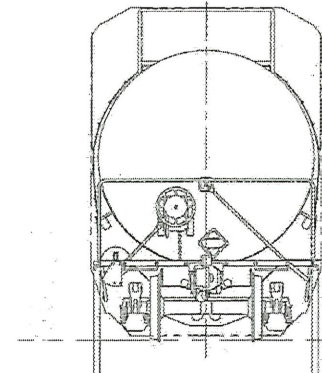
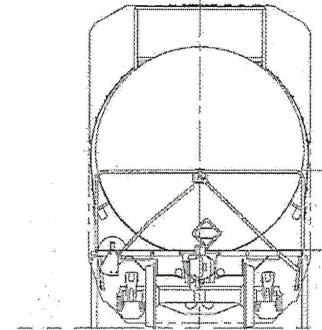
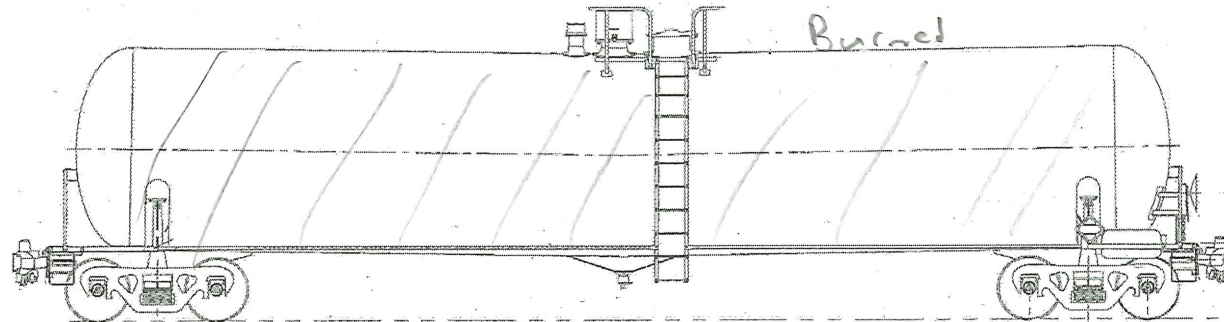
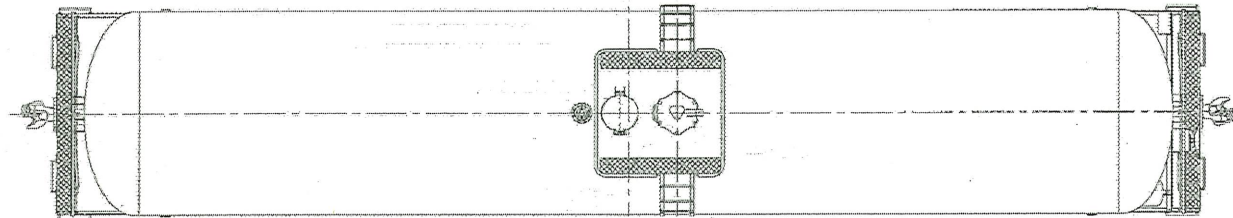
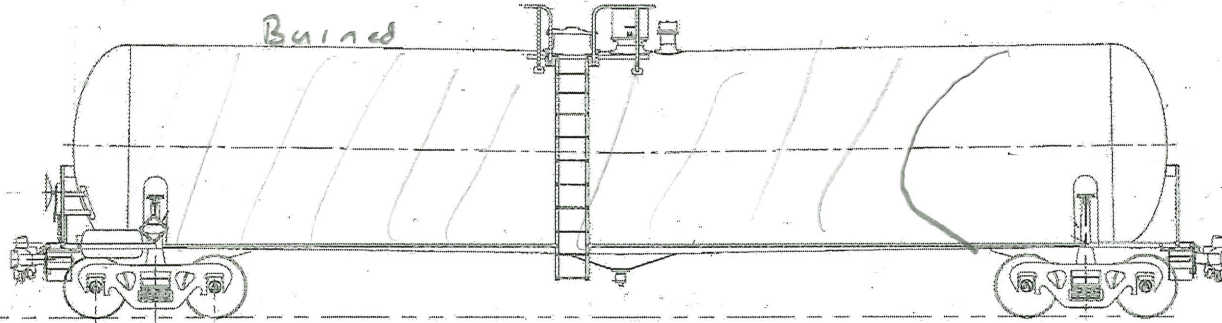

All components  
burned/melted

Builder Trinity  
Built Date 3-5-20  
DOT 117J100W  
File# T19039  
Loss of Commodity Yes / No  
Valves -Leaked / Sheared No

Top fittings MW OK MH OK  
Bottom Outlet Leg OK Handle DT OK  
Breach- Thermal Tear No Mech Tear No  
Draft Sill A OK B OK  
Head Shield A OK B OK  
PRD Functioned- Yes No

# Car Damage Report

3-12-15  
DGT-004 Vernon  
Rev 4

Car Number TILX 731757

Wreck index Number NA

Consist 72

Date of Derailment 1-8-22

Location OKLA Union Tx  
1987

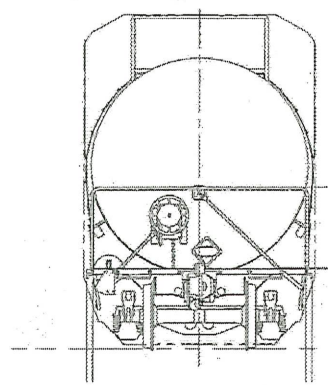
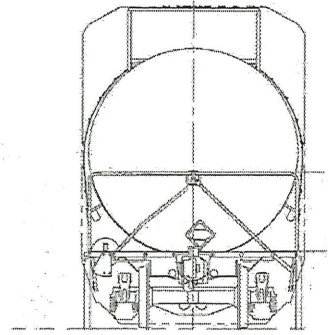
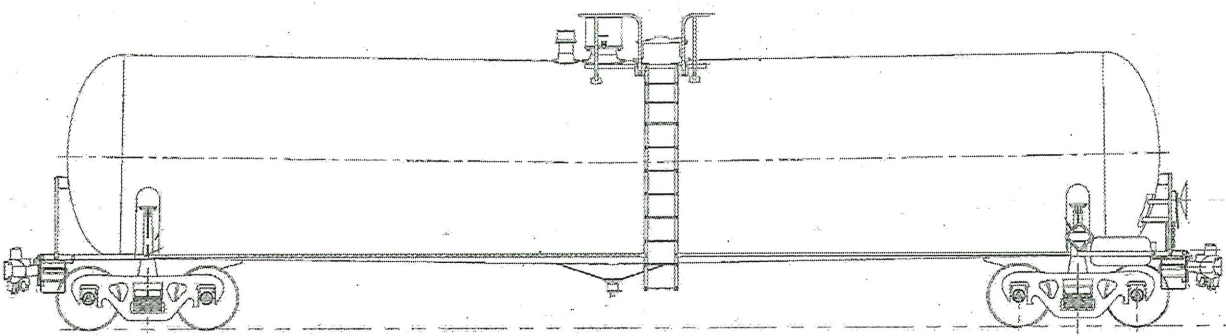
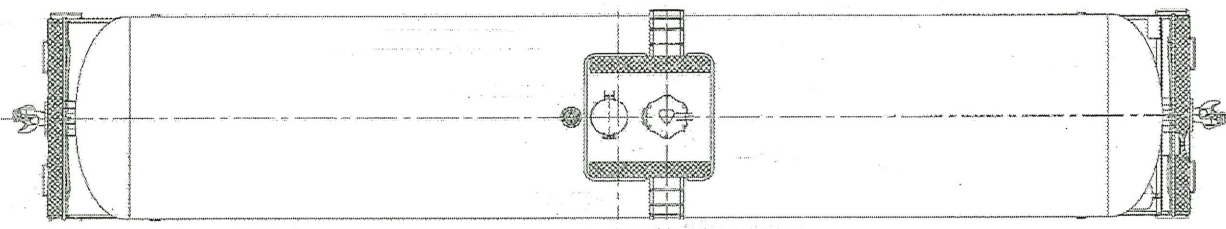
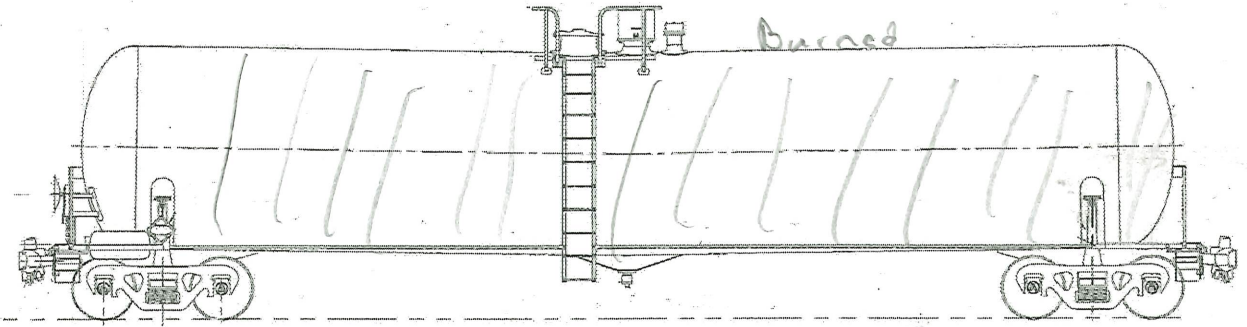

Builder Trinity  
Built Date 10-16-20  
DOT 117 J100W  
File# T19039  
Loss of Commodity Yes / No  
Valves -Leaked / Sheared No

Top fittings MW OK MH OK  
Bottom Outlet Leg OK Handle DT OK  
Breach- Thermal Tear No Mech Tear No  
Draft Sill A OK B OK  
Head Shield A OK B OK  
PRD Functioned- Yes No