



Highway Attachment 6 – SCI Smart Cushion Design and Installation Manual

HWY18FH011

(61 pages)



W O R K A R E A P R O T E C T I O N

SCI70GM AND SCI100GM DESIGN & INSTALLATION MANUAL

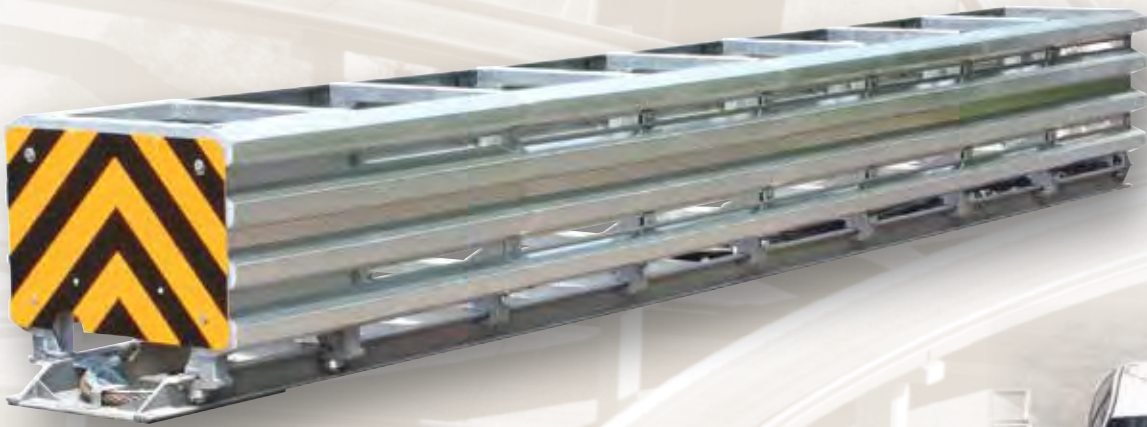

The World's Only
Speed-Dependent
Crash Attenuator

SMART CUSHION **INNOVATIONS**®

NCHRP 350 Approved

Corporate Office:
2500 Production Drive • St. Charles, IL 60174
Telephone: 800-327-4417
workareaprotection.com

TABLE OF CONTENTS

OVERVIEW	1
Product	1
Maintenance	1
Crash Performance	1
SPECIFICATIONS	2
Description	2
System Dimensions & Weight	2
DESIGN CRITERIA	2-5
General	2
Foundations	2
Support Structure	3
Location	3
Transition Design	4
Drawing List	5
INSTALLATION	6-9
Installation & Performance Statements	6
Safety	6
Equipment List	Appendix B
Site Preparation	6
Foundations	6
Placement of Crash Cushion	7
Anchor Installation	7
Delineator Panel Attachment	8
Transition Installation	8
Final Inspection	9
RESETTING CRASH CUSHION AFTER IMPACT	9-13
Site Preparation	9
Re-Extension & Inspection After Frontal Impact	9-10
Side Impact Inspection & Repair	11
Cable Inspection Procedure	11
Cylinder Inspection	12
Anchor Bolt Inspection	12
Side Panel Inspection	12
Side Guide Inspection	12
Final Inspection	13
Non-Repairable Impacts	13
Periodic Maintenance	13

APPENDICES

<u>SCI ATTENUATOR PARTS LIST</u>	A
<u>EQUIPMENT LIST</u>	B
<u>ATTENUATORS</u>	
SMART CUSHION®, TEST LEVEL 2	C
SMART CUSHION®, TEST LEVEL 3	D
<u>FOUNDATIONS</u>	
Test Level 2 Foundation	E1
Test Level 3 Foundation	E2
<u>LAYOUTS</u>	
Gore Assembly	F
Gore Assembly Calculations	F3
<u>TRANSITIONS</u>	
Jersey/F Shape Barrier	G
Concrete Block, 24 Inch (610 mm)	H
Concrete Block, 30 Inch (762 mm)	I
Concrete Block, 36 Inch (915 mm)	J
Concrete Block, 30 Inch (762 mm), Flared	K
Concrete Block, 36 Inch (915 mm), Flared	L
Thrie-Beam (Bidirectional Traffic Design)	M
W-Beam (Bidirectional Traffic Design)	N
Jersey/F Shape, 30-38 Inch (762-965 mm), Variable Width Base	O
Median Barrier, Single Slope 24-26.75 Inch Base (610-679 mm)	P
W-Beam 28 Inch Tall (unidirectional traffic design)	Q
W-Beam 32 Inch Tall (unidirectional traffic design)	R
Wide Block Spanner	S
Offset Wide Concrete Block	T
Concrete Block, 36-44 Inch (914-1118 mm), Flush Mount	U
Concrete Block, 46-48 Inch (1168-1219 mm), Flush Mount	V
Concrete Block, 50+ Inch, Flush Mount Reverse Direction Side	W



OVERVIEW

Product

The SMART CUSHION® impact attenuators are manufactured by SCI Products, Inc./Work Area Protection Corp. They are NCHRP Report 350, Test Levels 2 and 3 (TL2 and TL3) compliant (Models SCI 70 GM and SCI 100 GM, respectively) and are fully redirective, non-gating, and bi-directional. SMART CUSHION® impact attenuators are used to help protect motorists from hazards in both permanent and work zone locations. They can be attached to most types of median and roadside barriers.

The SMART CUSHION® attenuators use a patented system for stopping vehicles. The system is speed dependent and stops small and large vehicles by automatically regulating the stopping force exerted on a vehicle. Essentially, the system provides the necessary forces based on the speed of the vehicle automatically compensating for the mass of the vehicle.

The SMART CUSHION® attenuators are slightly tapered from front to rear. This allows the side panel sections to collapse over the next section without stress or damage. During collapse, the parts move freely past each other and do not become wedged during the impact.

Wide temperature variations and temperature extremes do not affect the performance of SMART CUSHION® impact attenuators. Temperature driven changes in viscosity of the fluid in the shock-arresting cylinder does not affect performance.

Maintenance

SMART CUSHION® impact attenuators are low-maintenance units. In a two-year in-service evaluation report submitted to the Federal Highway Administration, the average cost of parts to repair the SMART CUSHION® impact attenuator was \$39, excluding two catastrophic impacts. More than four out of five of the reported repairs only required two shear bolts costing under \$2. A trained, two-person maintenance crew can return most impacted SMART CUSHION® attenuators to full service within 30 minutes. This short repair time reduces the maintenance workers' exposure to traffic and minimizes motorist inconvenience. Side impacts rarely require a repair which eliminates exposure by 40%.

Crash Performance

The SMART CUSHION® broke new ground during NCHRP Report 350 crash testing. In the high-speed test, 100 kilometers per hour (63 miles per hour), the small vehicle's deceleration rate was significantly lower than any previously recorded value (-9.8 G's as compared to previous low of -13.4 G's). This means less impact forces on the vehicle's occupants and a reduced risk of injury and severity.

All the tests were conducted on the same SMART CUSHION® unit over four consecutive days with no damage to non-expendable parts. The only parts replaced after each crash test were the two shear bolts, costing less than \$2 for each reset.



SPECIFICATIONS

Description

The SMART CUSHION® is a re-directive, non-gating crash attenuator that consists of a base, supporting frames, a sled, side panels, a wire rope cable, sheaves, and a shock-arresting cylinder. The base is anchored to the mounting surface and provides support for the frames that are mounted on it. The support frames hold the side panels that provide a flat outer redirective surface for side impacts. The sled provides redirective support for side impacts and deceleration force for frontal impacts. The SMART CUSHION® telescopes rearward upon frontal impact and can be reset with minimal repair parts. It is NCHRP 350 approved at Test Levels 2 and 3.

System Dimensions & Weight

	SCI 70 GM	SCI 100 GM
Width	24 inch (610 mm)	24 inch (610 mm)
Length	13 ½ feet (4115 mm)	21 ½ feet (6550 mm)
Height	33 inch (840 mm)	33 inch (840 mm)
Weight	2465 lbs. (1120 kg)	3450 lbs. (1570 kg)
NCHRP 350, Test Level	2	3

DESIGN CRITERIA

General

SMART CUSHION® impact attenuators comply with NCHRP Report 350, TL2 and TL3, and are designed for work zone and permanent applications.

Foundations

Foundations must be a flat surface with longitudinal and cross slopes of 10:1 (horizontal: vertical) or less. SMART CUSHION® impact attenuators should not be located over drainage basins or expansion joints. Portland cement concrete foundation pads are preferred for permanent installations; asphaltic concrete foundation pads are appropriate for work zone installations.

The following table describes the foundations that may be used. See Appendices for drawings.

Foundations

Pad Material and Thickness	Anchor Embedment
6 inch (150 mm) reinforced PCC ¹	5 ½ inch (140 mm)
8 inch (205 mm) non-reinforced PCC	5 ½ inch (140 mm)
3 inch (75 mm) AC ^{2,3} over 3 inch (75 mm) non-reinforced PCC	16 ½ inch (420 mm)
6 inch (150 mm) AC over compacted subgrade ³	16 ½ inch (420 mm)
8 inch (205 mm) AC ³	16 ½ inch (420 mm)

Notes: 1. Portland cement concrete 2. Asphaltic concrete 3. Minimum compaction: 95% of optimal



Concrete compressive strength shall be 4000 psi (28 MPa) at 28 days.

Foundation lengths may vary when using wide transitions.

Support Structure

SMART CUSHION® impact attenuators are self-supporting and do not require an additional support structure.

Location

The SMART CUSHION® impact attenuator's location determines its position and transition requirements.

1. **Approach Zone** – SMART CUSHION® impact attenuators should not be placed directly behind raised curbs that exceed 4 inches in height. The longitudinal and cross slopes in front of the device should not exceed 10:1 (horizontal: vertical).
2. **Barrier Width** – SMART CUSHION® impact attenuators are 24 inch (610 mm) wide at the rear. Barriers 24 inch (610 mm) wide, or less, can be shielded without using a transition if there is no reverse direction traffic. Barriers that are wider than 24 inch (610 mm) and/or have reverse direction traffic require a transition, available from Work Area Protection Corp.
3. **Barrier Height** – SMART CUSHION® impact attenuators are approximately 33 3/8 inch (848 mm) high.
4. **Barrier Shape** – SMART CUSHION® transitions allow for connection to many barrier shapes.

Transition Design

SMART CUSHION® impact attenuators can be attached to many different barrier shapes. The attenuators are designed for direct attachment to 24 in wide barriers and Jersey/F-Shape barriers. **The SMART CUSHION® side panels move rearward beyond the end of the attenuator up to 30 inch (760 mm) upon impact.** This area is known as the travel zone. SMART CUSHION® transitions provide this travel zone in front of wider barriers and obstacles.

See appendices for SMART CUSHION® transition drawings. Work Area Protection Corp. can design transitions for other frequently used applications. Contact us for details.



Transitions

Necessary Locations (see Figure 1 – Necessary Locations):

- There is reverse direction traffic within the clear zone.
- The barrier intrudes into the side panels' travel zone.

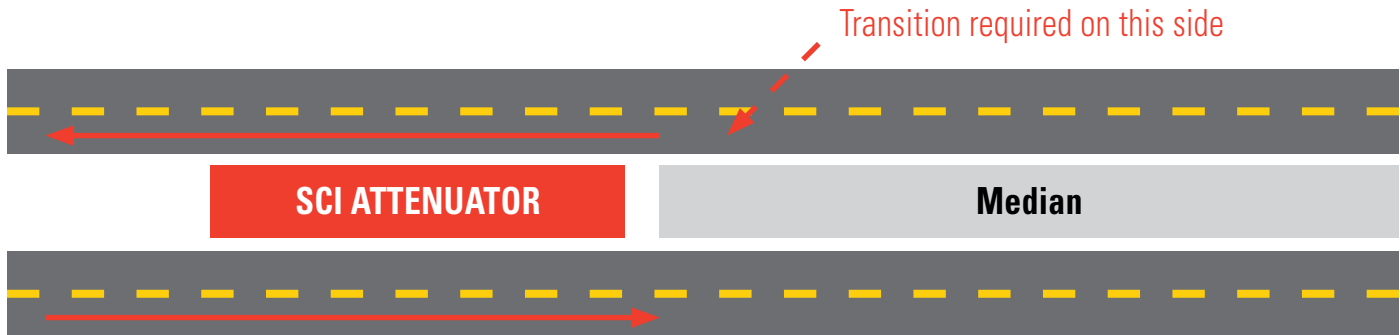

Figure 1 – Necessary Locations

Examples are median applications with bidirectional traffic, two lane roads with crossover potential, etc.

Unnecessary Locations (see Figure 2 – Unnecessary Locations):

- No reverse direction traffic within the clear zone.
- The barrier does not intrude into the side panels' travel zone.

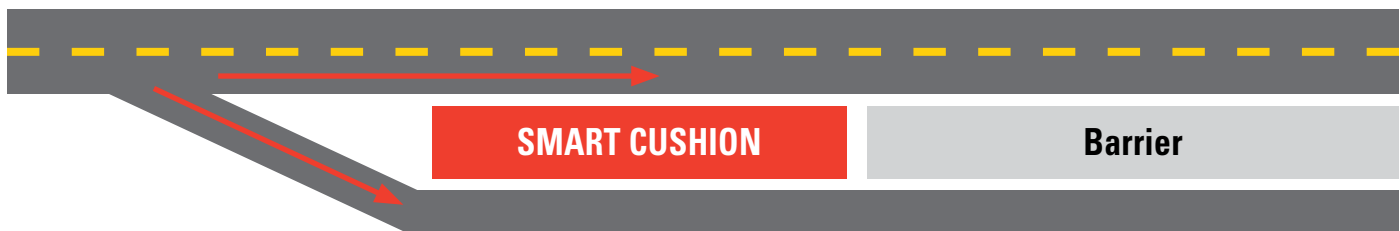

Figure 2 – Unnecessary Locations

Examples are traffic splits, shoulder applications with no crossover potential, one-way roads, etc.

Determining Side of Transition

The transition's side is determined by standing at the front of the attenuator looking rearward toward the barrier to choose between left and right.



Drawings

The following SMART CUSHION® transitions and layouts are available from Work Area Protection Corporation. Diagrams are shown in the Appendices as follows:

- Layout – Gore Assembly, Appendix F & F2 - Rigid design for wide obstacles
- Layout – Gore Assembly Calculations, Appendix F3 - Used to calculate longitudinal distances and parts requirements
- Transition - Jersey/F Shape, Appendix G - Used on standard Jersey/F shaped barriers with a 24 inch Base
- Transition - Concrete Block, 24 Inch, Appendix H - Used on 24 inch Concrete Block that must be 30 inch longitudinal length for our travel zone
- Transition - Concrete Block, 30 Inch, Appendix I - Used on 30 inch Concrete Block and will extend our installation length 38 inches
- Transition - Concrete Block, 36 Inch, Appendix J - Used on 36 inch Concrete Block and will extend our installation length 52 inches
- Transition - Concrete Block, 30 Inch, Flared, Appendix K - Used on 30 inch Concrete Block/Pillars and will extend our installation length 52 inches
- Transition - Concrete Block, 36 Inch, Flared, Appendix L - Used on 36 inch Concrete Block/Pillars and will extend our installation length 71 inches
- Transition – Thrie-Beam Rigid Assembly, Appendix M - Rigid design for possible reverse direction impacts
- Transition – W-Beam Rigid Assembly, Appendix N - Rigid design for possible reverse direction impacts
- Transition – Jersey, Median Barrier Variable Width, Appendix O - Used on Jersey Shape barrier with base widths of 30 - 38 inches wide.
- Transition – Single Slope Barrier, Appendix -P - Used on 42 inch and 48 inch Single Slope barrier up to 26 inches wide at the base
- Transition – W-Beam 28 Inch High, Appendix Q – Connection to 28 inch high W-Beam Guardrail with no reverse direction traffic
- Transition – W-Beam 32 Inch High, Appendix R – Connection to 32 inch high W-Beam Guardrail with no reverse direction traffic
- Transition – Wide Block Spanner, Appendix S – Connection to a wide Concrete Block for one sided protection
- Transition – Wide Block Offset, Appendix T – Connection where rear oncoming contact with the back side is not possible
- Transition – 36-44 Inch Flush Mount, Appendix U – Incremental widths for Bi-directional traffic.
- Transition – 46-48 Inch Flush Mount, Appendix V – Incremental widths for Bi-directional traffic.
- Transition – 50+ Inch Gore Reverse Direction Flush Mount, Appendix W – Incremental widths for Bi-directional traffic.



INSTALLATION

Installation and Performance Statements

Proper performance within these limits depends on correct installation of the SMART CUSHION® on an approved foundation. Any SMART CUSHION® not installed according to the drawings and the requirements of this installation manual may present an unsafe condition and should be reinstalled accordingly.

Impacts with vehicles whose size or mass are outside of those tested according to NCHRP 350 or with vehicles traveling at speeds greater than those tested according to NCHRP 350 will not necessarily produce results within the test criteria. The crash cushion is in conformance with all requirements of NCHRP 350 Levels 2 & 3 but is not guaranteed to safely stop a vehicle in a situation not encompassed by the test conditions.

Safety

All work during installation, repair and inspection of the SMART CUSHION® should be performed according to federal, state and local laws.

Equipment List

See Appendix B

Site Preparation

Check to make sure there are no drains, expansion joints, or buried conduit, cables or utility lines in the footprint space where the attenuator will be placed. Remove any curbs >4 inch or obstacles in front of or beside where attenuator will be installed for a minimum distance of 12 feet from any edge of the attenuator. Be sure to set up proper traffic control before beginning any installation or repair work at the site.

Foundations – (reference Appendices E1 and E2)

New foundations should be installed according to Appendix E – Foundation Drawing. Concrete should reach full cure strength before use. The surface of the foundation must be cleaned of all debris, dirt, mud, sand, etc., as the crash cushion must sit on a level plane, although longitudinal and/or cross slope of up to 10:1 (horizontal:vertical) is allowed.

Any of the following foundations will meet the minimum requirements:

- 6 inch reinforced concrete pad
- 8 inch non-reinforced concrete pad
- 3 inch asphalt over 3 inch of concrete
- 6 inch asphalt over 6 inch of compacted sub base
- 8 inch asphalt

Note: Concrete should be 28 MPa or 4000 psi minimum at full cure. The slope should not exceed 10:1.



Installing the SMART CUSHION® on an existing foundation may result in anchor bolt locations corresponding to rebar positions in the foundation. It may be necessary to use more elaborate drilling equipment than simply an impact drill with standard concrete bits.

Prior to installing the SMART CUSHION® on an existing foundation, the concrete must be thoroughly inspected for slope, signs of cracking, surface wear, shifting from original position, undercut of earth below or to the sides supporting the foundation, settling, and any other signs of age or deterioration which may make the foundation unusable. If any of these signs are evident, the foundation must be removed and a new one must be installed according to requirements stated. If prior bolt patterns are present, use proper engineering calculations to assure adequate strength in the new holes.

Placement of the SMART CUSHION®

Measure the correct distance and offset of the SMART CUSHION® according to the type of object being shielded and the type of transition being used. The dimensions shown on the transition drawings may be used as a guide for this. System drawings are also available.

The crash cushion is shipped in one piece, fully assembled. Use a choked four-point attachment on panel support frames 3 & 4 behind the sled for the Test Level 3 unit. The lift points on the Test Level 2 unit are the 1st and 2nd frames behind the sled. Lift the SMART CUSHION® off the transporting vehicle with a boom or forklift of sufficient capacity and place it in the position marked on the foundation.

Once in place, double-check the measurements to be sure of the proper location of the SMART CUSHION®.

Warning: On a full collapse, the last set of side panels will telescope 30 inches beyond the last terminal brace at the rear of the crash cushion. All objects that may interfere with this motion can affect the performance of and cause undue damage to the crash cushion.

Anchor Installation

Embedment Requirements are as follows:

1. 6 inch reinforced concrete pad – anchor embedment of 5 ½ inch and a torque value of 125 ft-lbs
2. 8 inch non-reinforced concrete pad – anchor embedment of 5 ½ inch and a torque value of 125 ft-lbs
3. 3 inch asphalt over 3 inch of concrete – anchor embedment of 16 ½ inch and a torque value of less than 10 ft-lbs
4. 6 inch asphalt over 6 in of compacted sub base – anchor embedment of 16 ½ inch and a torque value of less than 10 ft-lbs
5. 8 inch asphalt – anchor embedment of 16 ½ inch and a torque value of less than 10 ft-lbs



Using the holes in the base as a template, drill 7/8 inch diameter holes to the proper depth as previously defined. If the SMART CUSHION® is being installed on an existing foundation and the drills are hitting rebar, use a core drill or rebar cutter to ensure that straight, vertical holes are made at each location. Take care that the holes do not break out the bottom of the foundation as this may result in loss of epoxy during anchor placement.

Once the holes are drilled, clean the hole of all debris using suitable means. To ensure epoxy adhesion, **concrete holes MUST be cleaned with a bottle brush to remove embedded dust**, and a final check conducted that all holes are clean of debris and dry. Inject the epoxy into each hole at an angle to avoid air entrapment. Use a sufficient amount of epoxy so that the hole will be filled when the bolt is inserted. Screw the nut on the anchor bolt flush with the end, put the washer on the stud, and immediately insert the anchor stud all the way to the bottom while turning the anchor. This method assures the anchor bolts are vertically plumb and the threads are coated with epoxy. ****Stud locations should not project more than 1/2 inch above the nut after final torque is completed.**

There is a quantity of 48 anchors for the SCI 100 GM, TL-3 attenuator.

There is a quantity of 34 anchors for the SCI 70 GM, TL-2 attenuator.

The epoxy will be ready for bolt tightening after 30 minutes at 80 degrees F (27 degrees C). See the container label for other temperatures and bolt up times. Allow the epoxy to cure. Torque the anchor nuts to 170 N-m (125 ft-lbs). Substitute epoxy must match our specifications. Asphalt anchors are longer and should only be torqued to 10 ft-lbs. The SCI uses Redhead A7 Epoxy. Concrete TL2 and TL3 units require 3 and 4 tubes, respectively while Asphalt TL2 and TL3 units require 9 and 12 tubes, respectively.

Delineator Panel Attachment

Installation of the front delineation plate will be determined by the location of the attenuator and state regulations. A delineation plate is shipped with a yellow powder coat background and no striping. It is attached with four bolts. Applying the striping to the plate is easier while it is removed from the attenuator. Examples of the delineation plate are as follows:



Right Shoulder



Chevron for Medians



Left Shoulder

Transition Installation

Transitions may be required. Any use of a SMART CUSHION® with a possible reverse direction impact will require a transition. In all applications, be sure to install the transition anchors that are exposed to traffic, so that there is no extension of the studs beyond the outside face of the nut. Refer to the transition drawings for details of the required anchor locations. For horizontal stud installation in concrete use mechanical anchors, or if using studs repeat the same epoxy installation process as the anchor bolts using plugs to retain the epoxy to secure the transition to the barrier. Transition drawings and parts explosions are in the appendices.

Final Inspection

After the anchor bolts have been tightened to the proper torque value, check that the SMART CUSHION® is not distorted in any way as might happen if the unit is secured to a foundation which is not a flat plane. Check that the front section is pulled out to within 1 inch of the front stop bolts and that no part of the unit has been damaged by shipping and handling. Verify that all assembly bolts are tight and have not come loose during shipping or installation. Finally, check that no tools or other equipment have been left within the SMART CUSHION® structure.

Resetting SMART CUSHION® after Impact

In the event of any impact, the crash cushion will require a full evaluation to determine the necessary repairs to return it to service. To do this, proceed as follows:

Site Preparation

Do not begin work until the area is declared safe and accessible.

Re-Extension and Inspection after Frontal Impact

1. Remove the front delineator panel and attach pulling means to the **bottom brace** of the front sled.
2. Use wire or strap on the bottom brace at the front of the sled to hold the spelter socket up in the air while pulling out or it will catch on the base frame cross braces. (See Fig. 1)
3. Remove the front cable bracket that is located on the front sheave at the front of the attenuator. (See Fig. 2)
4. Attach a ½" Grade 100 chain to the bottom brace of the front sled.
5. Pull the sled forward one to two feet to give you slack on the cable.
6. If necessary, use Work Area Protection Corp's cable release tool to break cable loose from the sheave at the front of the attenuator if the zinc coating has attached the cable to the sheave. (See Fig. 3)



Fig. 1

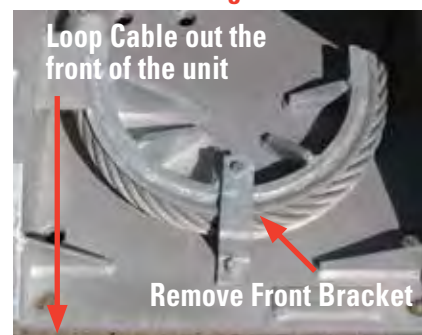

Fig. 2



Fig. 3

7. Pull out in two foot increments while helping the cable feed out of the front of the unit. (See Fig. 4)

8. Pull the sled out the rest of the way in **short smooth increments** so you can help feed the cable out the front of the attenuator. This will give you a cable loop in front of the attenuator. **When you are past the last cross brace, you will need to remove the strap or wire to allow the cable to follow the path into the front sheave.** The sled must be fully extended to replace the shear bolts. The sled should be approximately 1 inch from the stop bolts in the front.



Fig. 4

****During any pullout, do not stand within the snap radius of the chain in case of failure**.**

9. During frame pullout, inspect front part of the cable from the spelter socket, as it will be partially obscured after extension of the mobile frames and sheaves. **See the cable inspection procedure.**

10. Remove the front and rear sheave cover plates at each end of the cylinder by removing the two hex bolts that hold them down.

11. Remove the anti-rotation pins, which are the two outer pins, inserted through the holes in the sheaves from both the front and back sheaves. This will be easily done with Work Area Protection Corp's anti-rotation pin removal tool. **Caution: Do not remove the center pin. The rear pins are longer than the front sheave pins and cannot be intermixed so leave them by their locations.**

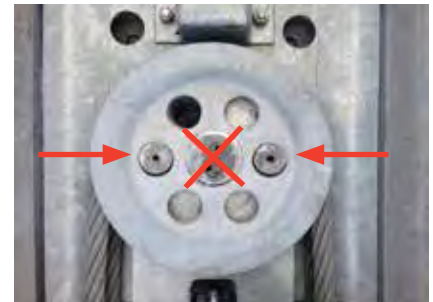

Fig. 5

(See Fig. 5)

12. Remove shear bolt remnants in the holes on both sides of the mobile sheaves. These are grade 8 bolts so they can be difficult to remove without a 90 degree pry bar with a claw to pry out. (See Fig. 6)



Fig. 6

13. Attach a pulling means to the shackle on the mobile sheave assembly. (See Fig. 6)

14. Slowly pull out the mobile sheaves. **Do not stand inside the cable loop or be in the pulling strap danger zone.**

15. Finish pulling out the mobile sheaves until you can see through the shear bolt holes **but do not put in the shear bolts yet.**

16. If the cable passes inspection, release any tension on your pulling strap and reinstall the anti-rotation pins in the front and back sheave assemblies and reinstall the cover plates for those sheaves using marine grade anti-seize on the bolt threads. The sheaves may be aligned by inserting a pry bar into the sheave holes. Work your way from the bottom up.

17. Put tension on your chain and replace the two ¼ inch **Grade 8** shear bolts in the front corners of the mobile sheaves.

18. Inspect the cylinder, anchor bolts and side panels according to the subsequent procedures listed.

Side Impact Inspection and Repair

1. Inspect and replace any damaged side panels.

2. Inspect and replace any damaged side keeper bolts on all panels. There are three styles of side keeper bolts. The winged style is for the panel connected to the sled and bolts through the first frame behind the sled. The center side keepers have a ½ inch shoulder while the last side keeper, which is bolted to the terminal frame, has a ¼ inch shoulder.

3. Inspect and repair any damaged side guides.

Cable Inspection Procedure

The cable should be visually inspected for damage. The most common sign of rope deterioration is broken wires. The wire must be clean and not under tension to perform a visual inspection. The visual inspection should include looking for broken wire strands, localized wear or crowns. A sharp awl or marlin spike can be used to separate wires to check if internal damage is present, indicated by loose wires or crowns. If internal inspection shows any damage to any core wires, the cable should be replaced. If there are more than six random broken wires in one rope lay or three broken wires in one strand in one rope lay, the wire rope should be replaced. A rope lay is the length along the rope in which one strand makes a complete revolution around the rope. (See Fig. 7)

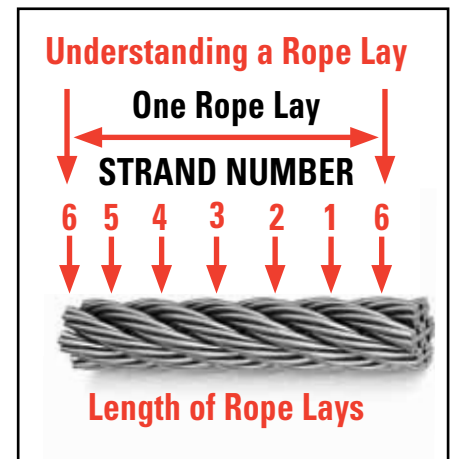

Fig. 7

Inspect the spelter socket for broken wires, damaged eyes or other fatigue. Any signs of broken wires at the spelter socket will require a new cable.

Cable damage is the indication of an over-design impact.

The unit must be inspected by an authorized manufacturers' representative.



Cylinder Inspection

The cylinder should be inspected for:

- Dented or swollen tube jacket
- Visible cracks in any welds and fluid leakage from the welds
- Piston rod surface damage, bending or fluid leakage in seal area
- If fully collapsed or over design impact speed, disconnect piston rod from the mobile sheave after the unit is pulled out and push the piston rod in checking for free movement.

If any of these inspections are suspect, replace cylinder and have it examined by the manufacturer. Current models have PTFE seals with an unlimited static life.

Anchor Bolt Inspection

Anchor bolts may come loose or be damaged upon impact. These bolts may be replaced by welding a nut or putting a double nut on them and backing them out of the hole. Drill out the old epoxy and reinstall new bolts with new epoxy following previous instructions on page 7.

Side Panel Inspection

Side Panels are designed to nest and collapse with minimal or no damage upon frontal impact. The side keepers sustain a shock upon impact. These side keepers should be replaced if there are any signs of fatigue, bending or other visible damage. Inspect the side panels for any bending or torn metal. If damage is found, any side panel is removable by removing four bolts. It may be necessary to remove the bolts on the panel upstream to slide out a panel located in the middle of the unit. The side keepers used to hold the large front sled panels are different than the side keepers on the center panels. Also, the side keeper used on the last terminal brace, which is the rearmost support, has a shorter shoulder ($\frac{1}{4}$ inch vs. $\frac{1}{2}$ inch), as it does not have a panel overlap. These shoulders must seat into the outer overlapping panel and pin the inside panel to the frames using a torque value of 270 N-m (200 ft-lbs). Be careful not to pin the edge of the outside panel as it will restrict free sliding of that panel.

Side Guide Inspection

At the bottom of each support frame, there are two guides to stabilize and guide collapse of the attenuator. Inspect each side guide for damage. These guide assemblies are very rugged. If the side guides are not damaged they can be reused. The torque value for the side guides is 920 N-m (680 ft-lb). These side guides are stronger than the rail, so visually inspect the rail for crowns. Any crowning of the rail can be straightened.



Final Inspection

After the resetting of the SMART CUSHION® is complete, verify by visual inspection that all assembly bolts are tight and show no sign of damage. Finally, check that no tools and other equipment or debris have been left within the SMART CUSHION® structure. Verify that no other damage unrelated to the most recent impact has occurred and that no significant corrosion or other deterioration has taken place.

Non-Repairable Impacts

There can be instances where the impact is outside the scope of the SMART CUSHION® design. This may render the SMART CUSHION® unsafe to reuse and it should be replaced.

Periodic Maintenance

Maintenance is very site dependent. Small amounts of debris and trash will not affect the performance of the SMART CUSHION®. Accumulations of dirt/mud can impede the collapse of any system. We suggest an annual cleanout of the system in the fall of the year. If sites are in locations prone to heavy rain/mud runoff, a bi-annual cleaning may be required.



APPENDIX A - SCI SMART CUSHION® ATTENUATOR PARTS LIST

Prod No.	Part No.	Description	Qty Per Unit TL2/TL3	Unit of Measure
270128	9400	Attenuator 24" wide w/Concrete Anchors TL3		
270127	9450	Attenuator 24" wide w/Asphalt Anchors TL3		
270126	9451	Attenuator 24" wide w/Concrete Anchors TL2		
270125	9452	Attenuator 24" wide w/Asphalt Anchors TL2		
270667	9401	Bolt Concrete Anchor 3/4" X 7" TL3 *(Included in P/N 9400)	*	KIT/48 pcs.
270663	9402	Bolt Asphalt Anchor 3/4" x 18" TL3 *(Included in P/N 9450)	*	KIT/48 pcs.
270666	9453	Bolt Concrete Anchor 3/4" X 7" TL2 **(Included in P/N 9451)	**	KIT/34 pcs.
270664	9454	Bolt Asphalt Anchor 3/4" x 18" TL2 **(Included in P/N 9452)	**	KIT/34 pcs.
271242	9439	Epoxy 28 oz. Cartridge and Nozzle ***	***	EACH
272612	9515	Epoxy Kit for TL3 Concrete Attenuator		EACH
272610	9516	Epoxy Kit for TL3 Asphalt Attenuator		EACH
272611	9517	Epoxy Kit for TL2 Concrete Attenuator		EACH
272609	9518	Epoxy Kit for TL2 Asphalt Attenuator		EACH
270677	9405	Bolt Front Stop	2	EACH
270683	9406	Bolt Shear	2	EACH
270687	9408	Bolt Terminal Brace	4	EACH
270770	9409	Brace Terminal	1	EACH
274915	9413	Strap Cylinder TL3	1	EACH
233936	9448	Strap Cylinder TL2	1	EACH
272527	9421	Keeper Side #3 (Sled Panels) TL2 & TL3	4	EACH
272593	9422	Keeper Side #1 (Side Panels) TL2 & TL3	8/20	EACH
272595	9423	Keeper Side #2 (Rear Panels) TL2 & TL3	4	EACH
273378	9424	Panel Delineator (Painted Yellow) TL3	0/1	EACH
273386	9496	Panel Delineator (Painted Black) TL3		EACH
273381	9497	Panel Delineator Diamond Grade Chevron 6 inch stripes TL3		EACH
273383	9498	Panel Delineator Diamond Grade Left 6 inch stripes TL3		EACH
273389	9499	Panel Delineator Diamond Grade Right 6 inch stripes TL3		EACH
273380	9456	Panel Delineator (Painted Yellow) TL2	1/0	EACH
273385	9506	Panel Delineator (Painted Black) TL2		EACH
273382	9501	Panel Delineator Diamond Grade Chevron 6 inch stripes TL2		EACH
233928	9502	Panel Delineator Diamond Grade Left 6 inch stripes TL2		EACH
273388	9503	Panel Delineator Diamond Grade Right 6 inch stripes TL2		EACH
273401	9425	Panel Side TL2 & TL3	4/10	EACH
273402	9426	Panel Sled	2	EACH
273399	9427	Panel Rear	2	EACH
274649	9429	Sled (with guide rollers) 24" TL3	0/1	EACH
274648	9457	Sled (with guide rollers) 24" TL2	1/0	EACH
271242	9439	Epoxy 28 oz. Cartridge and Nozzle ***	***	EACH
273113	9440	Nozzle Epoxy Mixing ***	***	EACH
271946	9441	Dispenser Epoxy	0	EACH
270707	9443	Boot Cylinder TL3	1	EACH
233937	9449	Boot Cylinder TL2	0	EACH
272621	9488	Reset Parts Kit TL3	0	EACH
272620	9489	Reset Parts Kit TL2	0	EACH



APPENDIX A - SCI SMART CUSHION® ATTENUATOR PARTS LIST (continued)

Prod No.	Part No.	Description	Qty Per Unit TL2/TL3	Unit of Measure
273994	9495	Tool Anti Rotation Pin Removal	0	EACH
270069	9507	Anchor Drop In	0	EACH
273590	9508	Pin Anti-Rotation Front	0	EACH
273608	9509	Pin Anti-Rotation Rear	0	EACH
273667	9510	Plate Sheave Cover	0	EACH
233449	9524	PWB02 Block Out	0	EACH
275224	9525	Cable Release Tool	0	EACH
238247	9536	Shear Bolt Removal Tool	0	EACH
270952	9519	Hole Brush-Nylon	0	EACH
264383	9566	Drop-in Anchor Setting Tool	0	EACH
262004	9564	SCI Debris Hood Assembly- DH3	0	EACH
262006	9565	Fiberglass Stay Kit for Debris Hood - DH3	0	KIT
Transitions and Transition Parts				
275297	9431	Transition Jersey Barrier - Right	0	EACH
275294	9432	Transition Jersey Barrier - Left	0	EACH
275263	9433	Transition 24" Concrete - Left & Right	0	EACH
275298	9437	Transition Thrie & W Beam - Right	0	EACH
232971	9438	Transition Thrie & W Beam - Left	0	EACH
275309	9511	Transition W Beam 28" High Right	0	EACH
275307	9512	Transition W Beam 28" High Left	0	EACH
275311	9513	Transition W Beam 32" High Right	0	EACH
275310	9514	Transition W Beam 32" High Left	0	EACH
275279	9459	Transition Assembly 30" Concrete Straight Connection	0	EACH
275283	9460	Transition Assembly 36" Concrete Straight Connection	0	EACH
275278	9461	Transition Assembly 30" Concrete Outside Connection	0	EACH
275282	9462	Transition Assembly 36" Concrete Outside Connection	0	EACH
275288	9475	Transition Assembly Gore to End of Flared Transition	0	EACH
270765	9474	Thrie Beam Concrete Leg Brace	0	EACH
239542	9528	Transition Assembly Median Barrier Variable Width with Rub Rail	0	EACH
239545	9535	Transition Assembly Median Barrier Variable Width w/o Rub Rail	0	EACH
275299	9490	Transition Single Slope 24-26 9/32" Wide Median Barrier - Right	0	EACH
275302	9491	Transition Single Slope 24-26 9/32" Wide Median Barrier - Left	0	EACH
275271	9480	Transition Rub Rail Median Barrier-Right	0	EACH
275270	9481	Transition Rub Rail Median Barrier-Left	0	EACH
275291	9469	Transition Concrete Spanner Brace	0	EACH
265580		Steel Tube Blockout	0	EACH
		***Additional transitions are available		
		O = Optional		
		Revised 7-2015		



APPENDIX B - EQUIPMENT LIST

The following tools and equipment will be required to install and repair the Crash Cushion:

- Standard roadside work area safety equipment
- Personal safety equipment (gloves, latex gloves for epoxy, eye/face protection, etc.)
- Means of safely unloading 3500 lbs.
- Compressed air source/vacuum
- 1 inch nylon bottle brush
- Safety goggles
- Four lifting slings or four-point sling
- Bosch rotary hammer drill 13 ½ amp #11263EVS Model 0 611 263 739 or equal
- 7/8 inch X 22 inch concrete drill bit for concrete installations or 7/8 inch X 28 inch drill bit for asphalt installations
- Renton rebar eater bit #RB-14 - 7/8 inch rebar cutter bit or equal
- 1 inch X 12 inch concrete drill bit for drop-in anchors on transitions
- Punch or setting tool for drop in anchors.
- ½ inch electric drill for rebar bit and bottle brush (cordless will work for bottle brush)
- Epoxy dispenser for 28 oz. dual cartridge system (should have spare in case of malfunction)
- Socket wrench and breaker bar
- Torque wrench (225 ft-lb capacity) with 3 ft extension
- Measuring and layout equipment (tape measure, chalk line, markers, etc.)
- Combination wrenches, deep sockets (Including 7/16 inch - 5/8 inch, 1 ¼ inch, 1 ½ inch, 1 ¾ inch) and 3+ inch extension
- 5 foot wedge and round-ended pry bar
- Loctite #34395 marine grade anti-seize
- Suitable pulling means – Chain 20' x ½" Grade 100
- Misc. small tools (hammers, pliers, screw drivers, vise grips, etc.)
- Bear claw pry bar to remove ¼ inch shear bolt remnants
- Anti-rotation pin removal tool
- Cable release tool
- Piece of wire or bungee cord to hold up spelter socket during pullout

This list is adequate for general installation and repair. Depending on site conditions, additional tools and equipment may be required.

APPENDIX C - SMART CUSHION , TEST LEVEL II

PARTS LIST

- 01 - Front Sled
- 02 - Cable Assembly
- 05 - Sled Panel
- 07 - Terminal Brace
- 09 - Anchor Bolts
- 12 - Side Panels
- 14 - Mobile Sheave Asbly
- 17 - Cable Adjuster Bolt
- 18-20 - Mobile frames 4-6
- 28 - Cylinder
- 27 - Rear Panel
- 08 - Sled Side Keeper
- 06 - Center Side Keeper
- 29 - Rear Side Keeper

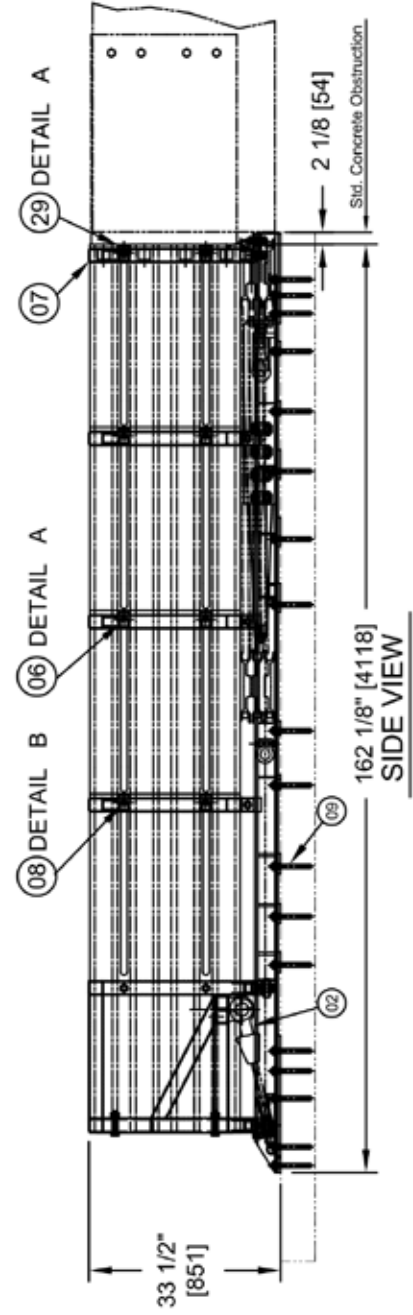
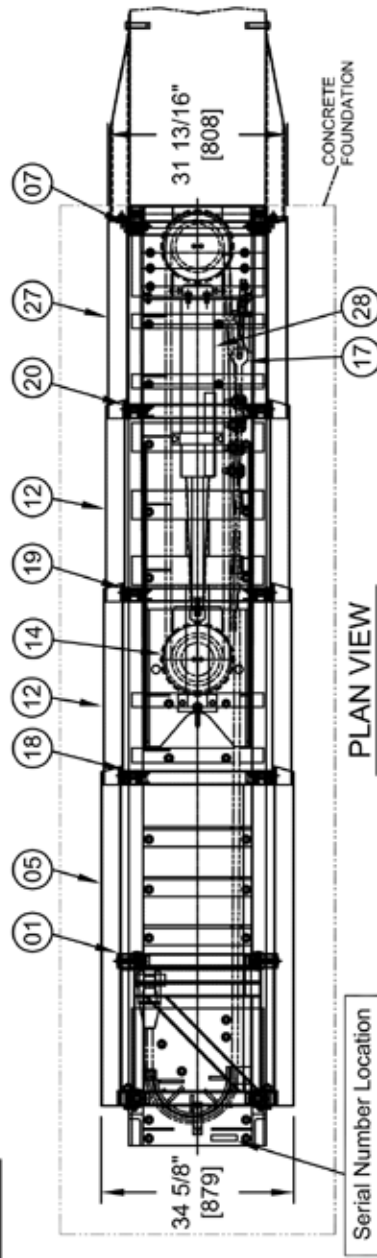
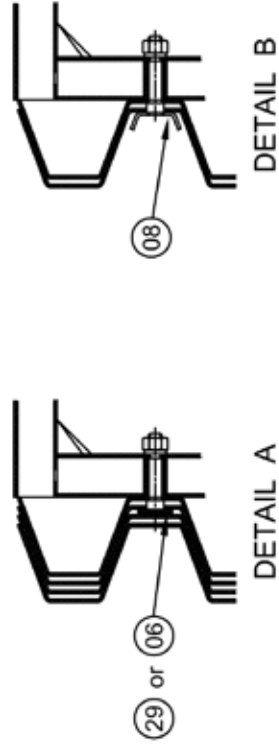

APPENDIX D - SMART CUSHION , TEST LEVEL III

- PARTS LIST**
- 01 - Front Sled
 - 02 - Cable Assembly
 - 05 - Sled Panel
 - 07 - Terminal Brace
 - 09 - Anchor Bolts
 - 12 - Side Panels
 - 14 - Mobile Sheave Asbly
 - 17 - Cable Adjuster Bolt
 - 18-23 - Mobile frames 1-6
 - 26 - Cylinder
 - 27 - Rear Panel
 - 08 - Sled Side Keeper
 - 06 - Center Side Keeper
 - 29 - Rear Side Keeper

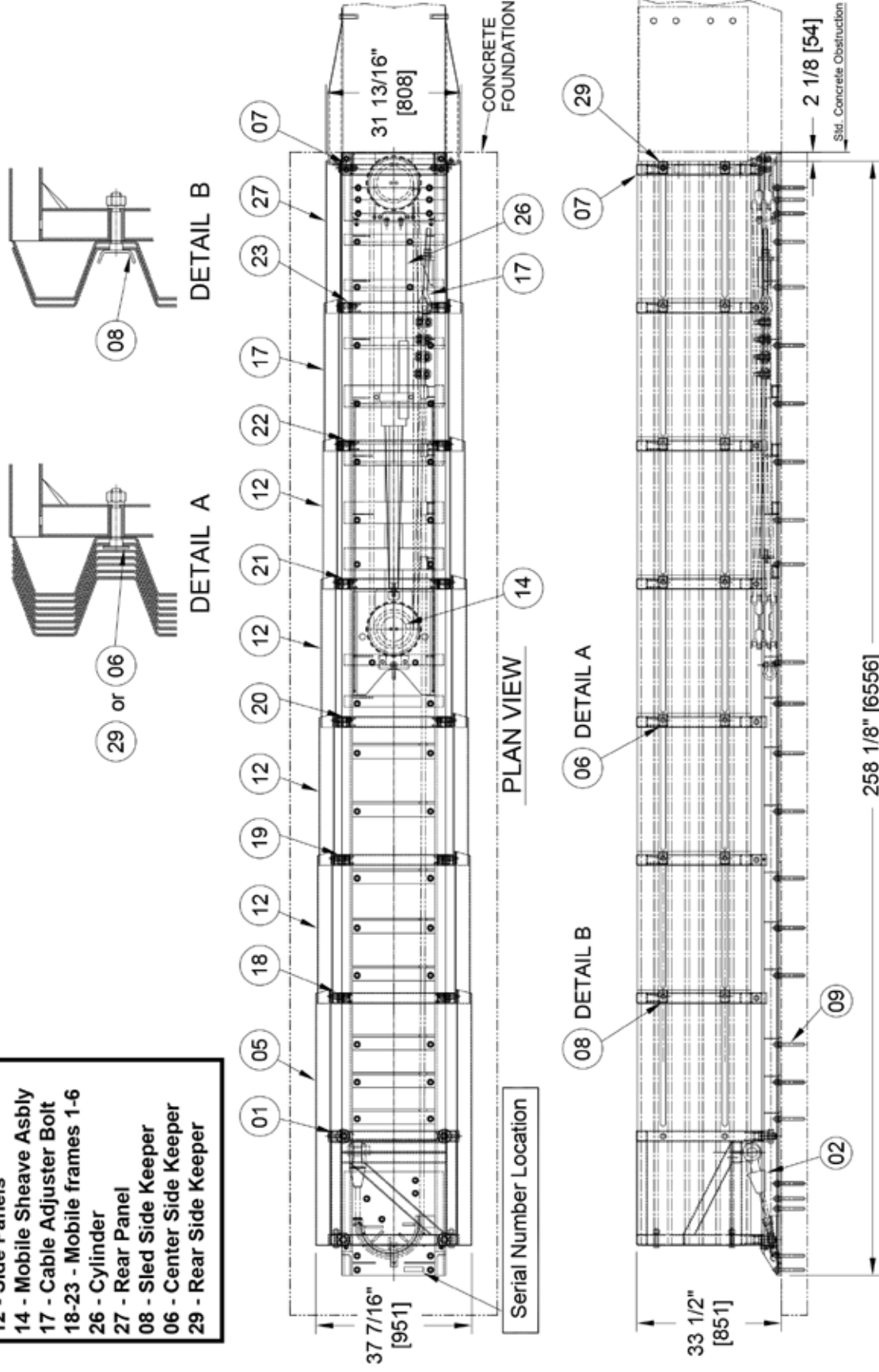

Serial Number Location

258 1/8" [6556]

2 1/8" [54]
Sld. Concrete Obstruction

PLAN VIEW

SIDE VIEW

DETAIL B

DETAIL A

CONCRETE FOUNDATION

06 DETAIL A

08 DETAIL B

33 1/2" [851]

37 7/16" [951]

31 13/16" [808]

APPENDIX E1 - TEST LEVEL II FOUNDATION

Cross Slope at Top Surface not to Exceed 1 in 10
Foundation must be a Level Plane

*** Wide Hazards and Transitions may require the foundation to be longer. See Transition Drawings.

SPECIFICATIONS

All reinforcing steel - straight #4 ASTM-A36

Embedment requirements:

- 6" reinforced concrete pad with anchor embedment of 5 1/2"
- 8" nonreinforced concrete pad with anchor embedment of 5 1/2"
- 3" asphalt over 3" concrete with anchor embedment of 16 1/2"
- 6" asphalt over 6" of compacted subbase with anchor embedment of 16 1/2"
- 8" asphalt with anchor embedment of 16 1/2"

The contractor shall furnish a certification for material installed to the following requirements:

- 6" reinforced concrete (PCC) sampling per ASTM C31-84, testing per ASTM C39-84
- 8" nonreinforced concrete (PCC) sampling per ASTM C31-84, testing per ASTM C39-84
- 3" asphalt over 3" concrete - Type SP 12.5 Level C or higher
- 6" asphalt over 6" of compacted subbase - same as above
- 8" asphalt (AC) - Type SP 12.5 Traffic Level C or higher

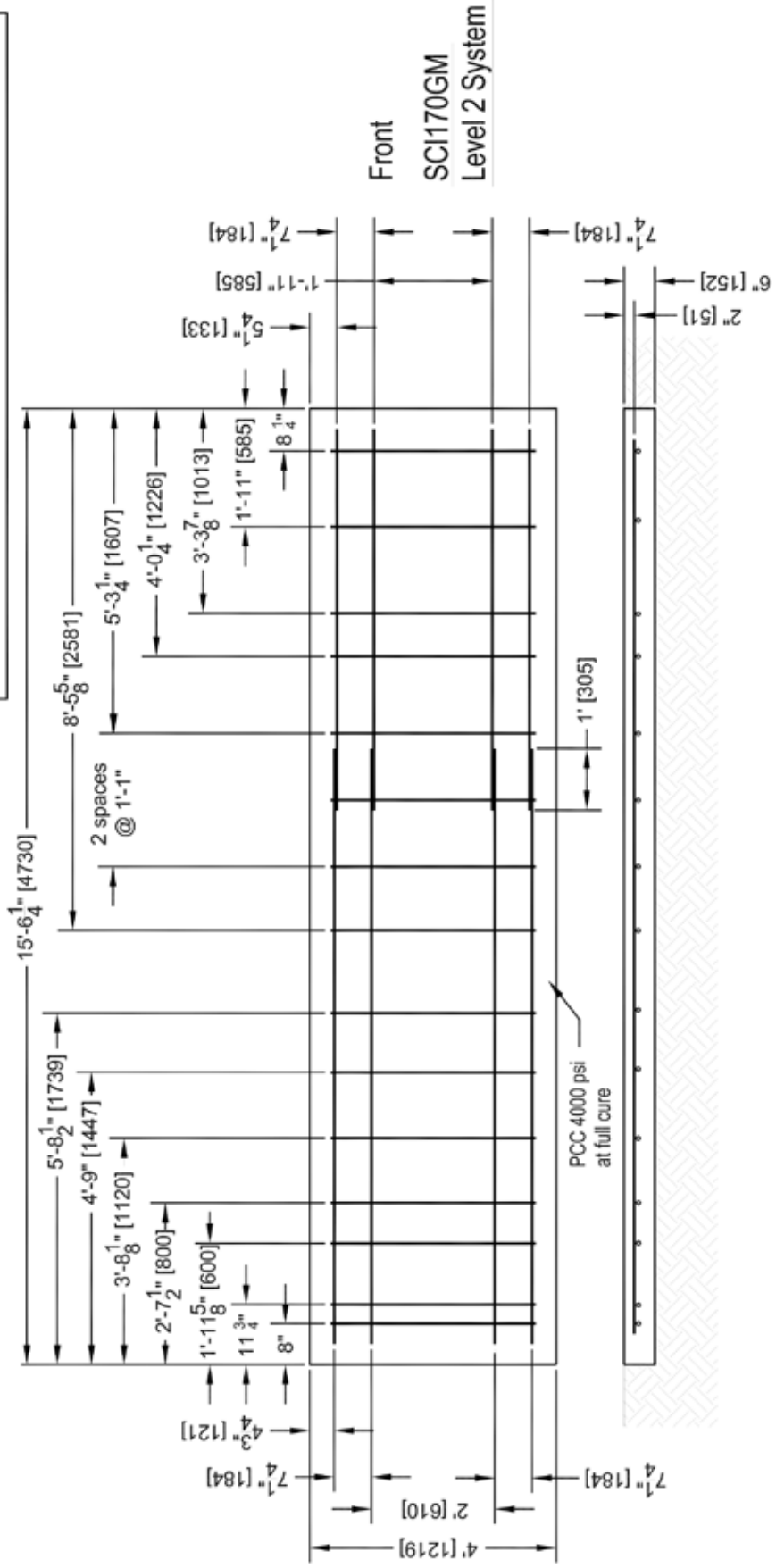

APPENDIX F - TRANSITION, THRIE BEAM WIDE TAPER

- Parts List:**
- Gore Assembly Complete to Brace #5 - #275288
 - 01-Transition Thrie 10 Degree Flare Right #275304
 - 01-Transition Thrie 10 Degree Flare Left #275306
 - 02-Transition Concrete Spanner Brace #275291
 - 03-Transition Concrete #1 Tapered Spanner Brace #275290
 - 04-Transition Gore Tapered #1 Spanner Brace #275292
 - 05-Transition Gore Tapered #2 Spanner Brace #275293
 - 06-Thrie Beam Concrete Leg Brace #270765
 - 07-Thrie Beam Blockout AASHTO PWB02 #265244

SPLICE BOLTS AND GUARDRAILS BY OTHERS

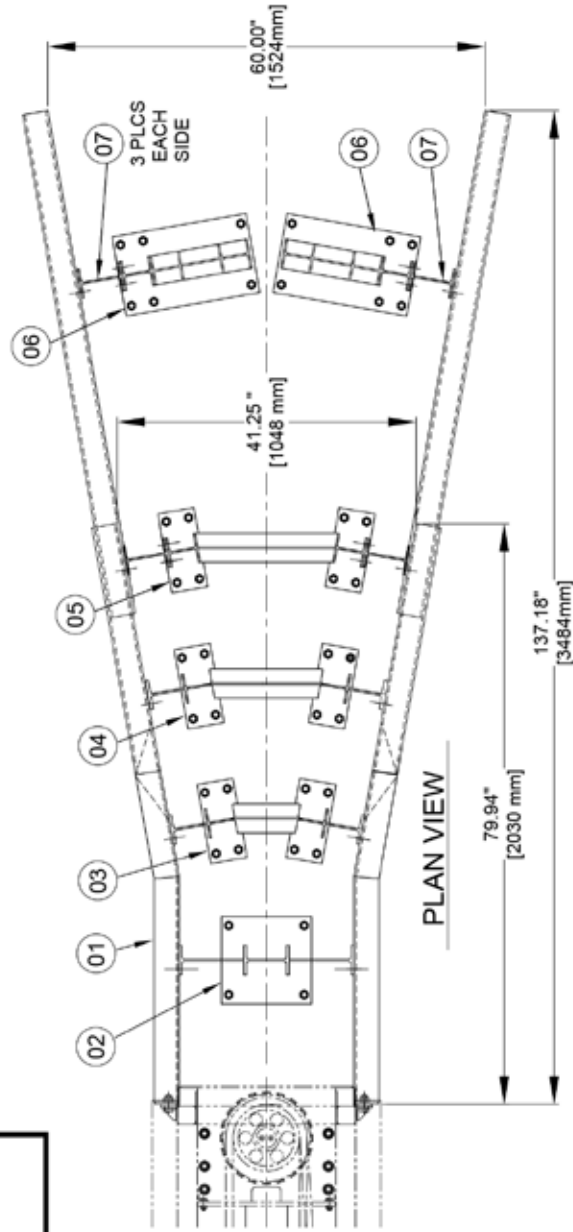

NOTES:

- 1) DIMENSIONS SHOWN ARE FOR 60" WIDTH FOR EACH 1" OF WIDTH CHANGE. ADD OR SUBTRACT THE FOLLOWING:
2.88" [73.15mm] TO LENGTH OF GUARDRAIL
2.84" [72.13mm] TO OVERLAP LENGTH
- 3) ADD OR SUBTRACT ADDITIONAL POST ON EACH SIDE FOR EACH 13" [330mm] CHANGE IN WIDTH.
- 4) GUARDRAIL TERMINATION - YOU MUST ADD THE GUARDRAIL OVERLAP LENGTH AND TERMINATE PER STATE REGULATIONS.

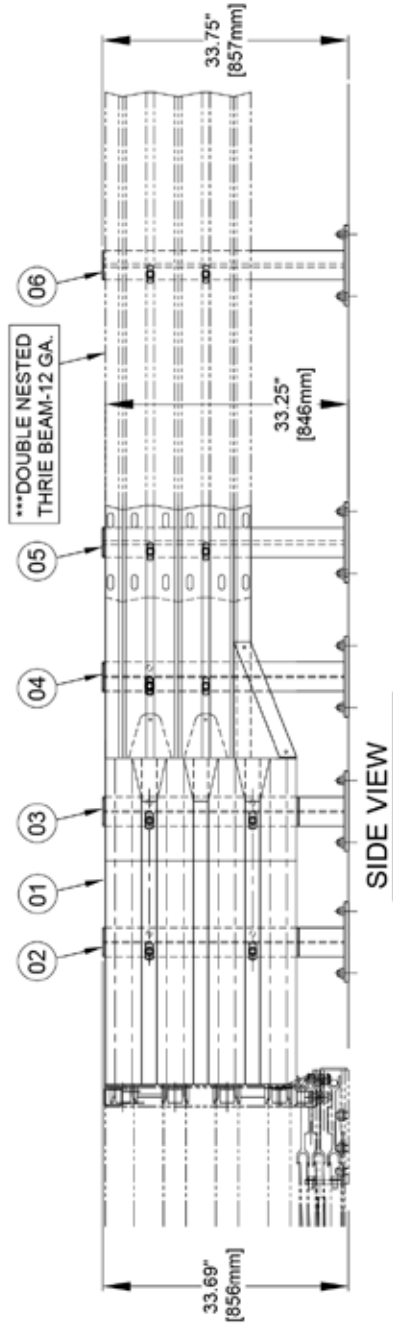

The use of the last brace will be determined by whether the Thrie Beam can be attached to the obstruction or not. If the Thrie Beam distance from the last brace is 40 inches or less and can be attached, you will not need a brace at the obstruction. If you cannot attach to the obstruction, you may need a brace and drill holes in the Thrie Beam at the furthest rearward location.

APPENDIX F(2) - TRANSITION, THRIE BEAM WIDE TAPER

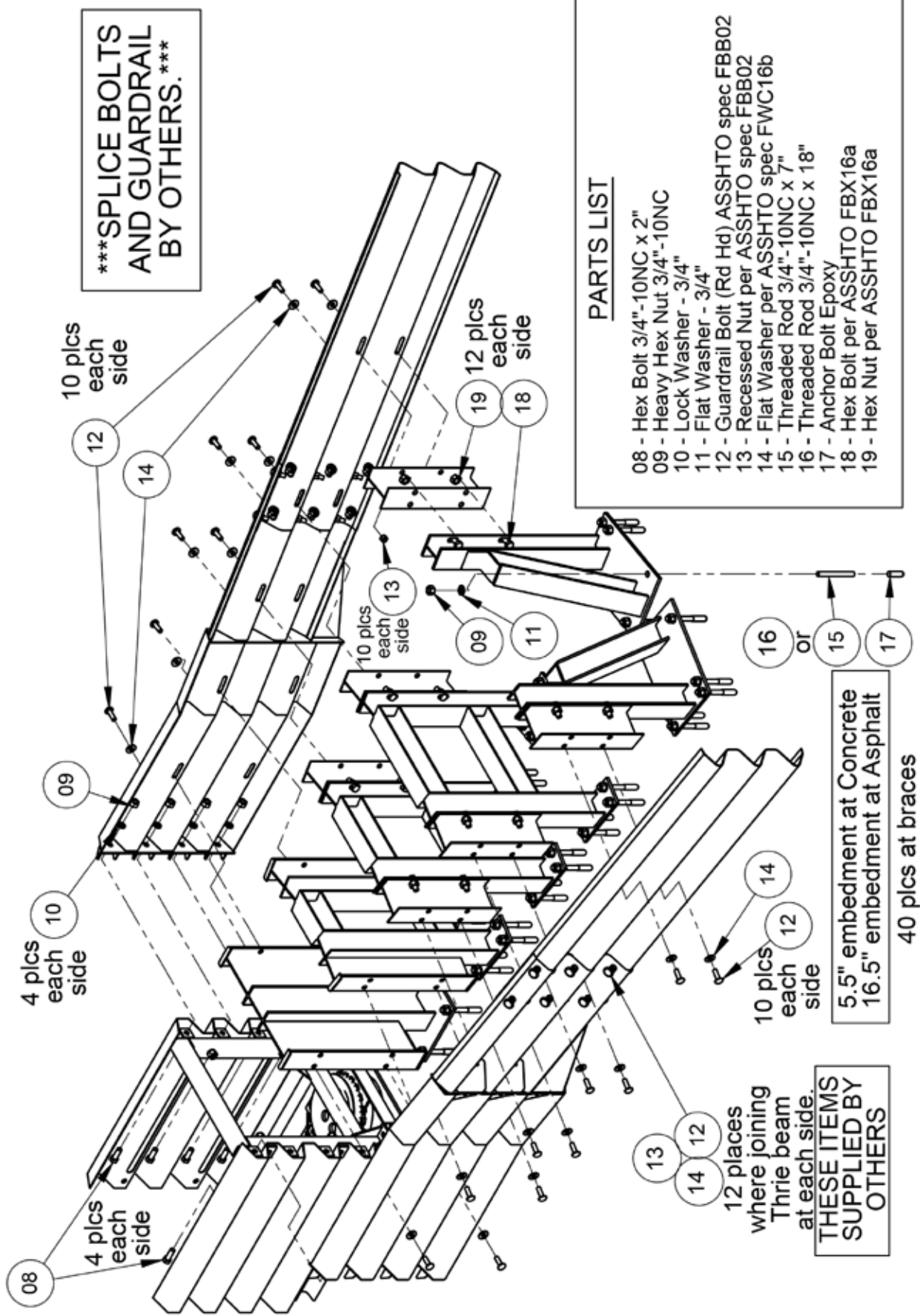

APPENDIX F(3) - TRANSITION, THRIE BEAM WIDE TAPER CALCULATIONS

SCI GM WIDE TRANSITION CALCULATIONS

Guardrail

12.6" Splice overlap at Transition end

Must add length for barrier overlap and end termination per state specifications

Longitudinal distance increases 2.84" for each 1" increase in width Thrie Beam Length increases 2.88" for each 1" increase in width

Gore Width Inches	Additional Long. Distance Inches	Additional Long. Distance Feet	Thrie Beam Length Inches	Overall System Length Feet	Gore Assembly	Additional Brace Count
41	80	6.7	16	28.2	#275288 Gore Assembly	Add 0-Thrie Beam Concrete Leg Brace #270765
48	100	8.4	36	29.9	#275288 Gore Assembly	Add 0-Thrie Beam Concrete Leg Brace #270765
55	120	10.0	57	31.5	#275288 Gore Assembly	Add 2-Thrie Beam Concrete Leg Brace #270765
60	134	11.2	71	32.7	#275288 Gore Assembly	Add 2-Thrie Beam Concrete Leg Brace #270765
68	157	13.1	94	34.6	#275288 Gore Assembly	Add 4-Thrie Beam Concrete Leg Brace #270765
69	160	13.3	97	34.8	#275288 Gore Assembly	Add 4-Thrie Beam Concrete Leg Brace #270765
81	194	16.1	131	37.6	#275288 Gore Assembly	Add 6-Thrie Beam Concrete Leg Brace #270765
90	219	18.3	157	39.8	#275288 Gore Assembly	Add 6-Thrie Beam Concrete Leg Brace #270765
94	231	19.2	169	40.7	#275288 Gore Assembly	Add 8-Thrie Beam Concrete Leg Brace #270765
100	248	20.6	186	42.1	#275288 Gore Assembly	Add 8-Thrie Beam Concrete Leg Brace #270765
107	267	22.3	206	43.8	#275288 Gore Assembly	Add 10-Thrie Beam Concrete Leg Brace #270765
112	282	23.5	221	45.0	#275288 Gore Assembly	Add 10-Thrie Beam Concrete Leg Brace #270765
120	304	25.3	244	46.8	#275288 Gore Assembly	Add 12-Thrie Beam Concrete Leg Brace #270765
126	321	26.8	261	48.3	#275288 Gore Assembly	Add 12-Thrie Beam Concrete Leg Brace #270765
133	341	28.4	281	49.9	#275288 Gore Assembly	Add 14-Thrie Beam Concrete Leg Brace #270765

APPENDIX G - TRANSITION, JERSEY/F SHAPE

Parts List:
01 - Transition Jersey Barrier Right #275297 (shown)
01 - Transition Jersey Barrier Left #275294 (not shown)

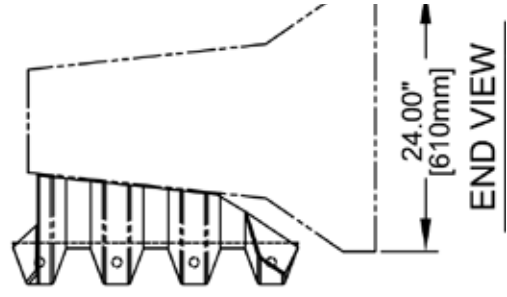
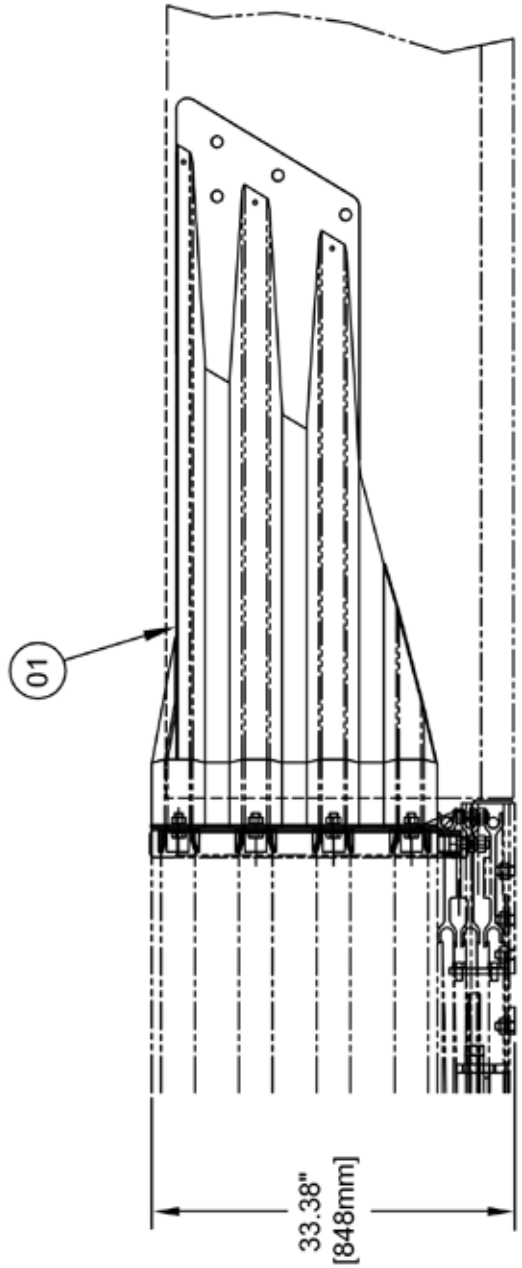
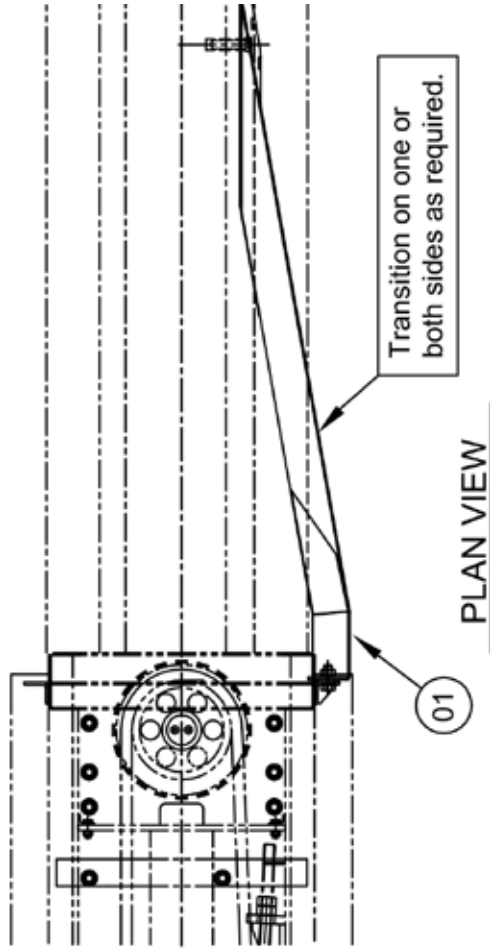

APPENDIX G(2) - TRANSITION, JERSEY/F SHAPE BARRIER

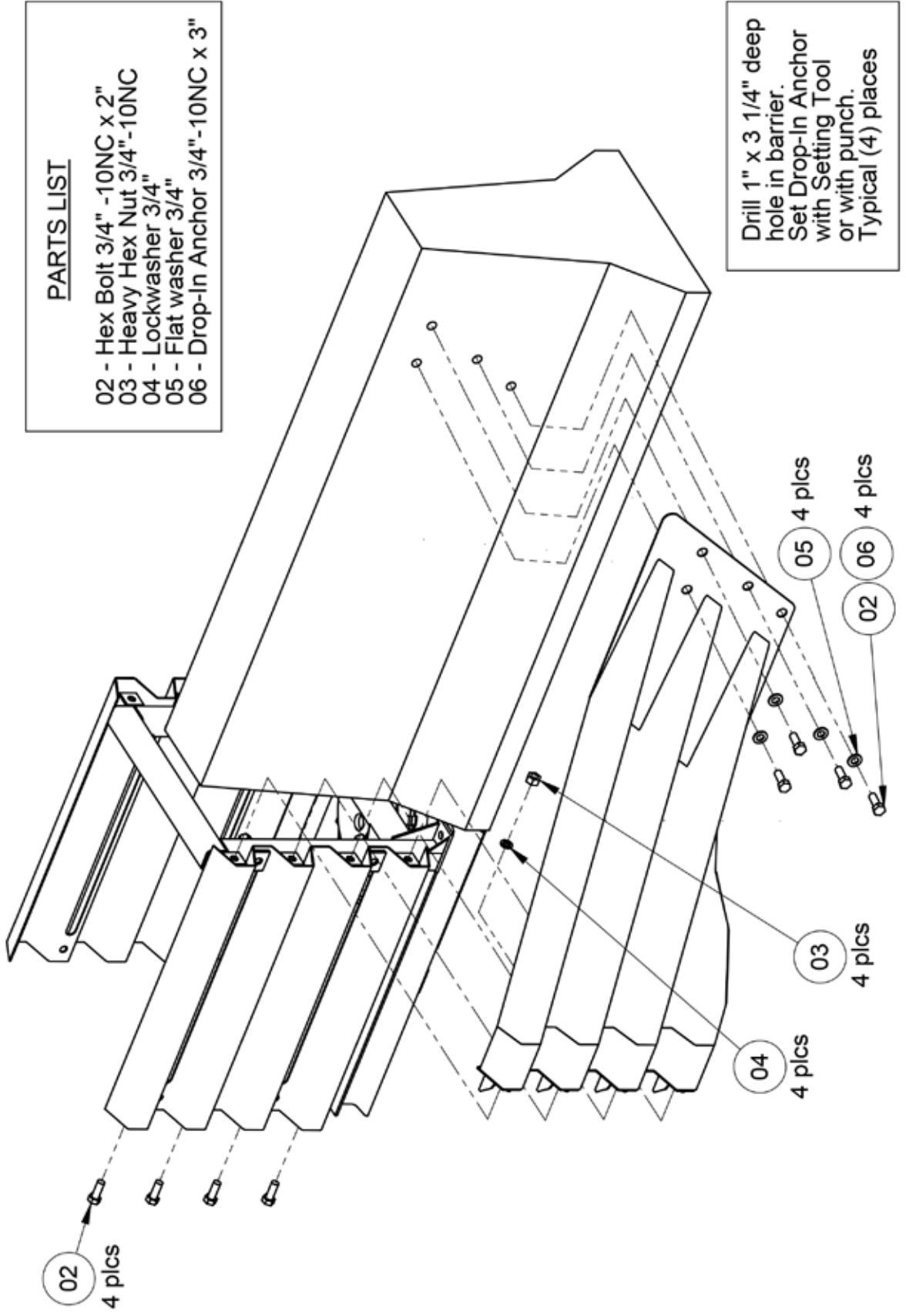

APPENDIX H - TRANSITION. CONCRETE BLOCK, 24 INCH (610mm)

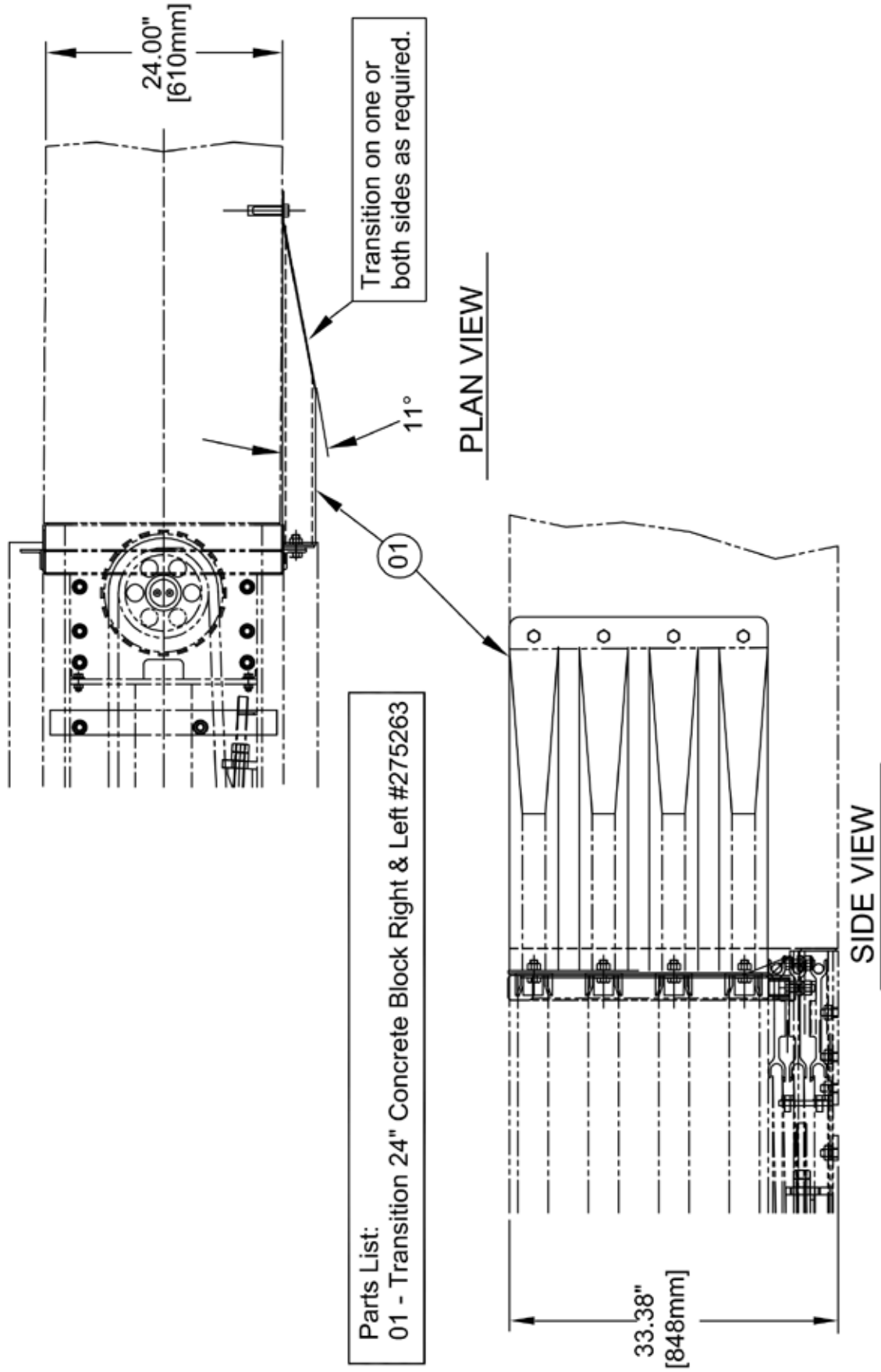

- Parts List:
01 - Transition 24" Concrete Block Right & Left #275263

APPENDIX H(2) - TRANSITION, CONCRETE BLOCK, 24 INCH (610mm)

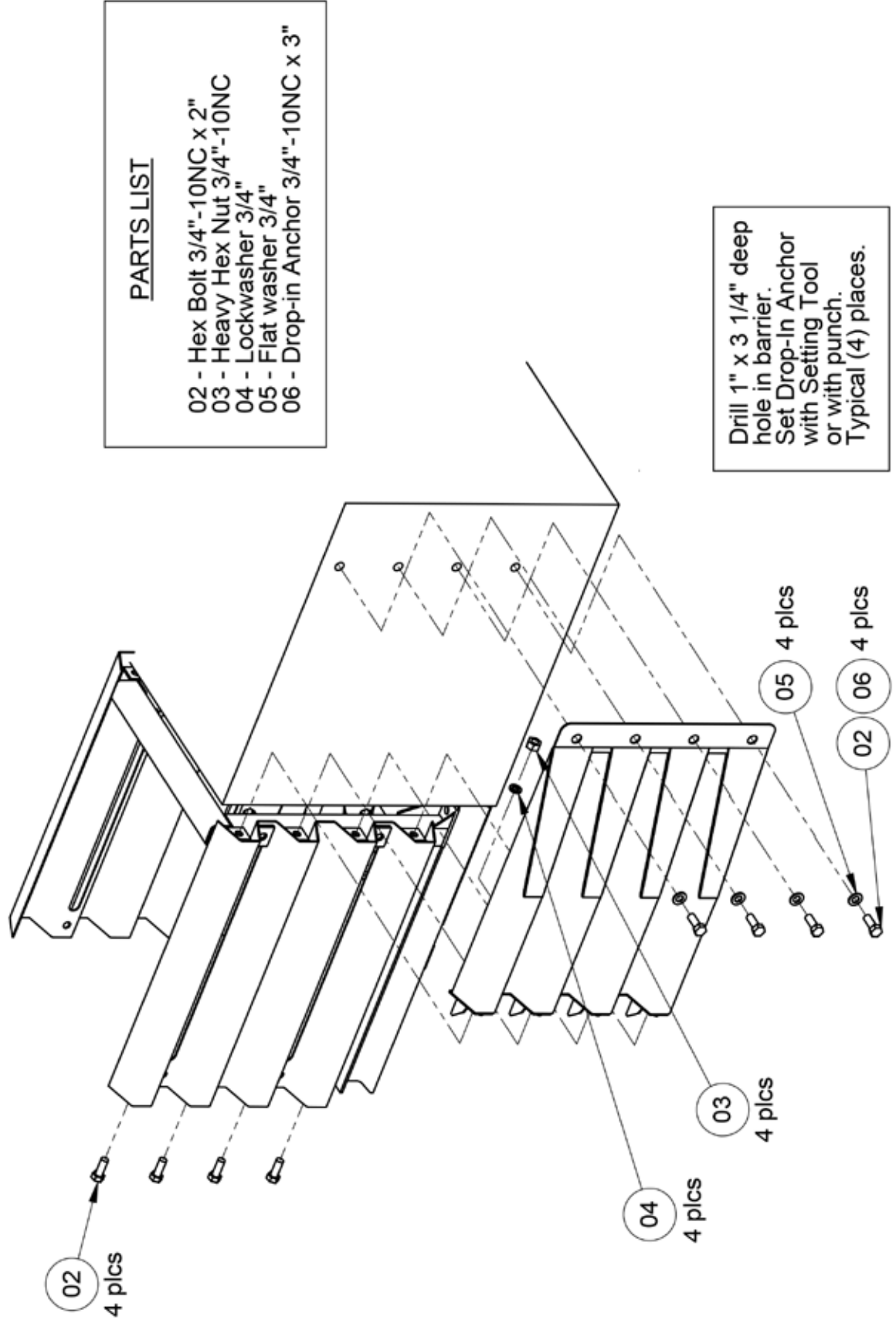

APPENDIX I - TRANSITION, CONCRETE BLOCK, 30 INCH (762mm)

Parts List:
 Two-Sided Full Assembly #275279
 01 - Transition 30" Concrete Straight Connection #275265
 02 - Transition Concrete Spanner Brace #275291

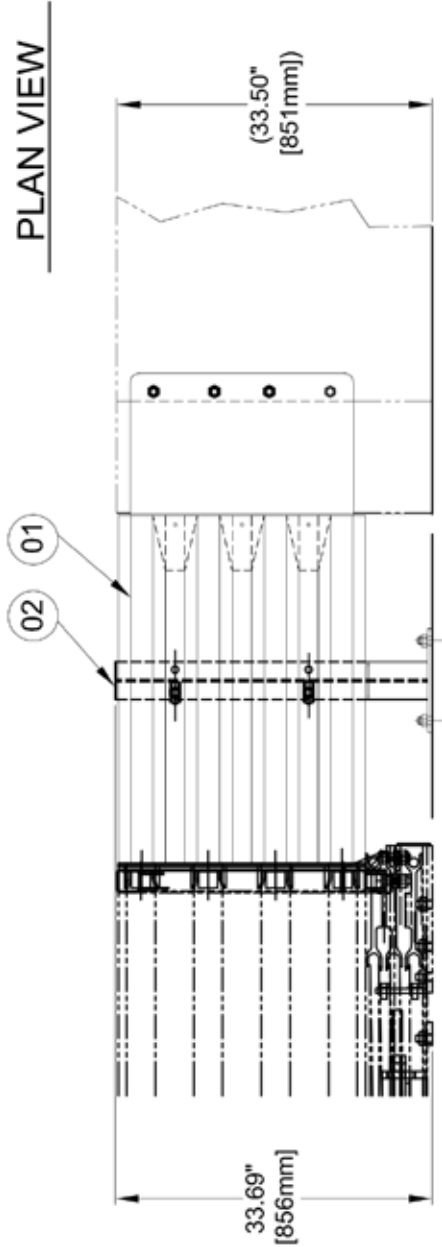
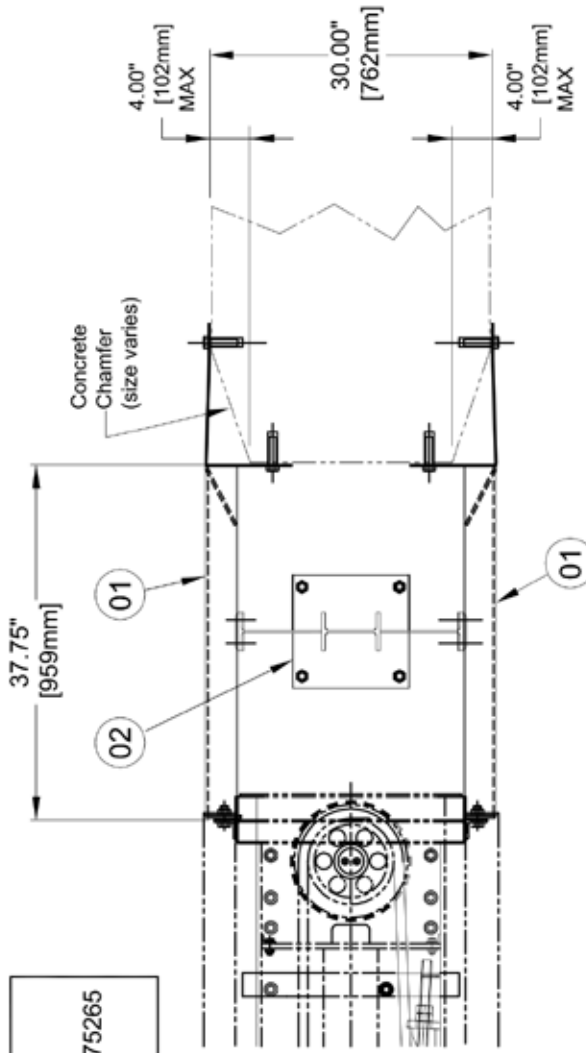

USED FOR:
 1. Unchamfered Concrete Block ***
 2. Chamfered Concrete Block ***
 Chamfer limited to <4"

APPENDIX I(2) - TRANSITION, CONCRETE BLOCK, 30 INCH (762mm)

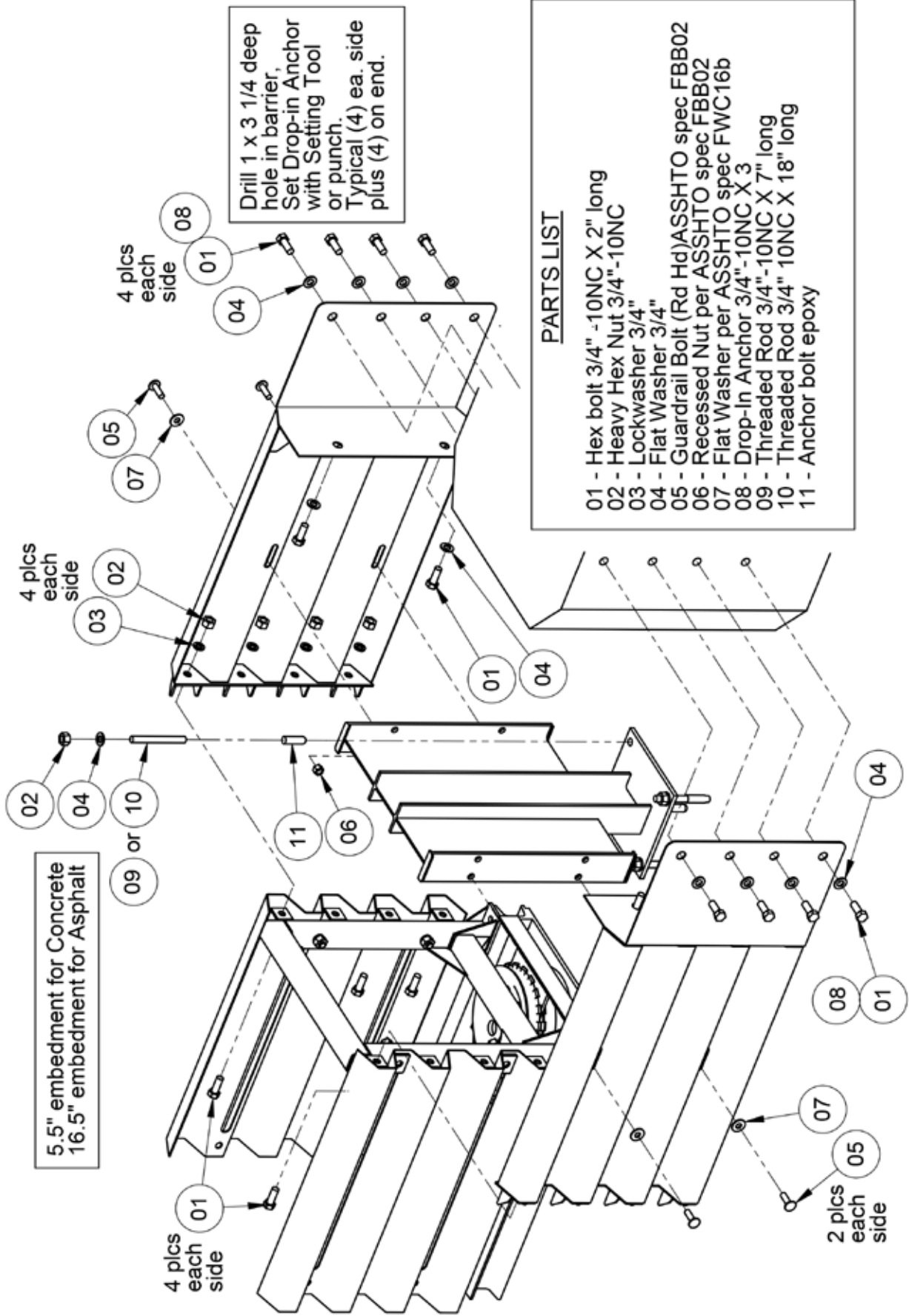

APPENDIX J - TRANSITION, CONCRETE BLOCK, 36 INCH (915mm)

- Parts List:
 Two-Sided Full Assembly #275283
 01 - Transition 36" Concrete Straight Connection #275267
 02 - Transition Concrete Spanner Brace #275291
 03 - Transition Concrete #1 Tapered Spanner Brace #275290

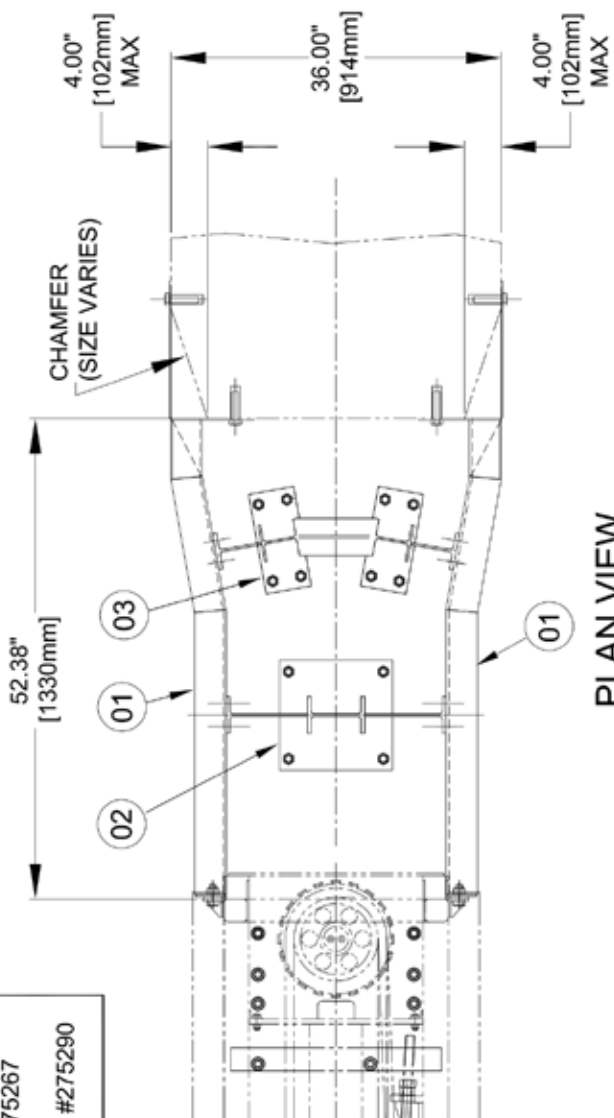

PLAN VIEW

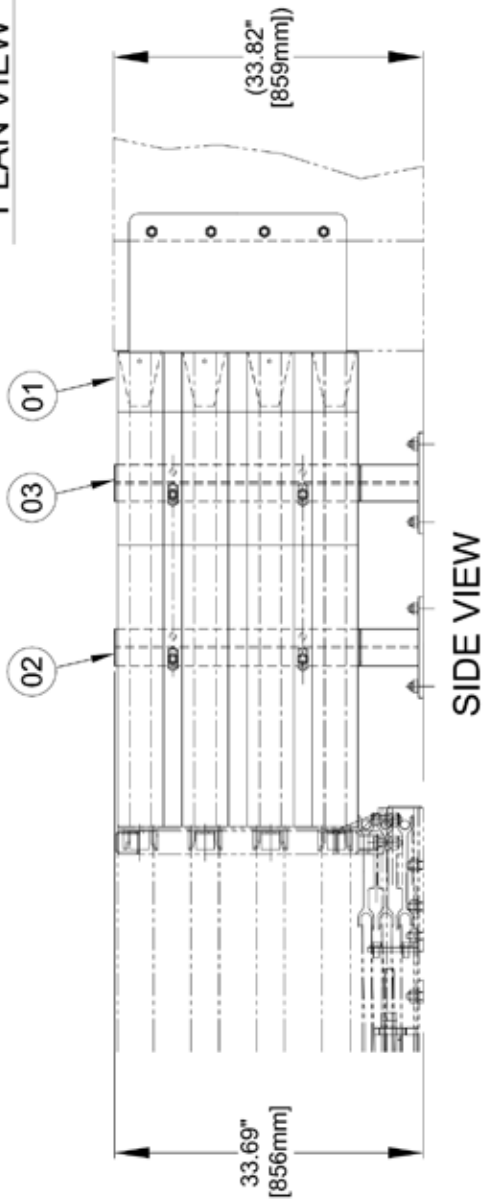

SIDE VIEW

USED FOR:
 1. Unchamfered Concrete Block ***
 2. Chamfered Concrete Block ***
 ***Chamfer limited to <4"

APPENDIX J(2) - TRANSITION, CONCRETE BLOCK, 36 INCH (915mm)

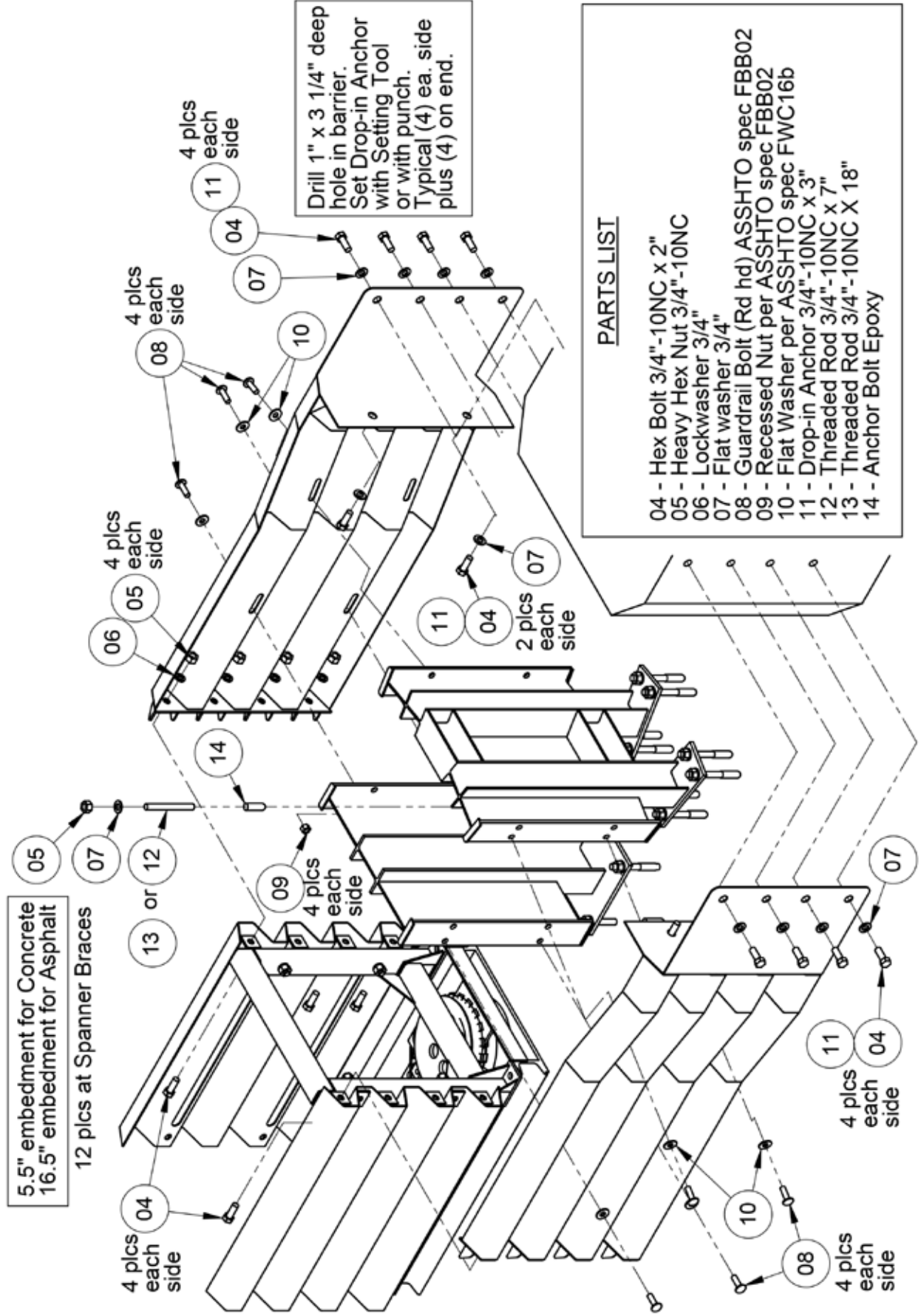

APPENDIX K - TRANSITION, CONCRETE BLOCK, 30 INCH (762mm)

- Parts List:
 Two-Sided Full Assembly #275278
 01 - Transition 30" Concrete Outside Connection #275266
 02 - Transition Concrete Spanner Brace #275291
 03 - Transition Concrete #1 Tapered Spanner Brace #275290

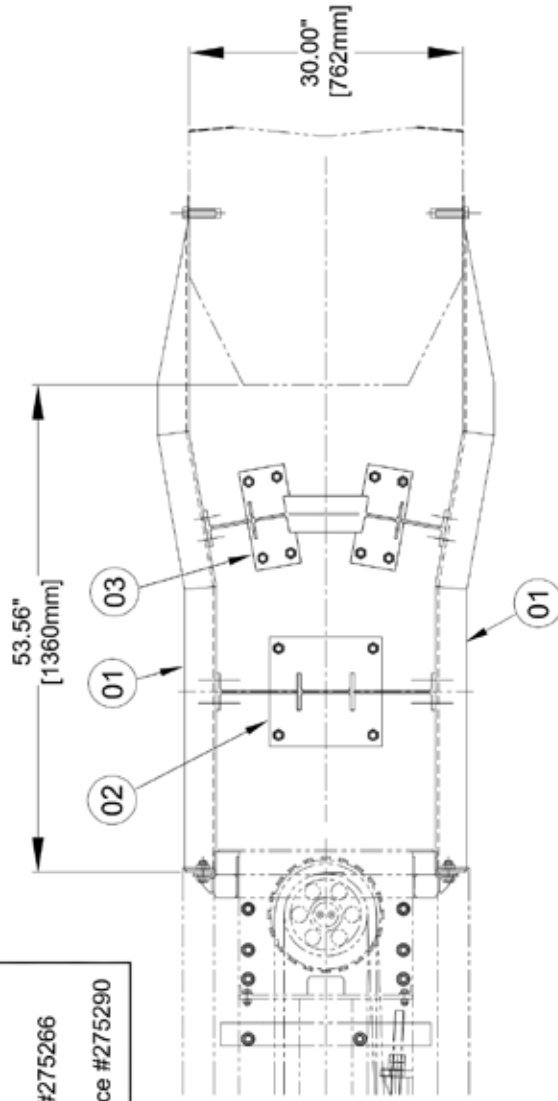

PLAN VIEW

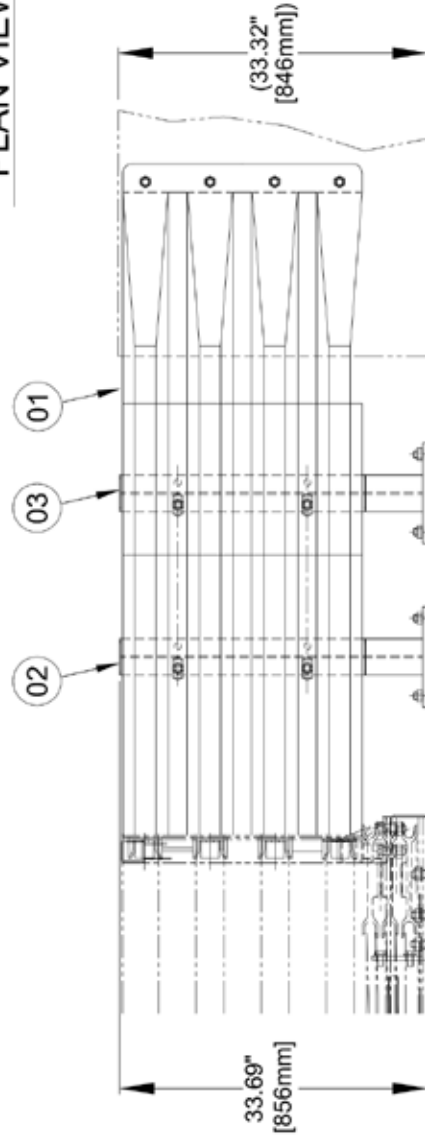

SIDE VIEW

USED FOR:
 1. Unchamfered Concrete Block ***
 2. Chamfered Concrete Block ***
 *** Chamfer limited to <4"

APPENDIX K(2) - TRANSITION, CONCRETE BLOCK, 30 INCH (762mm) FLARED

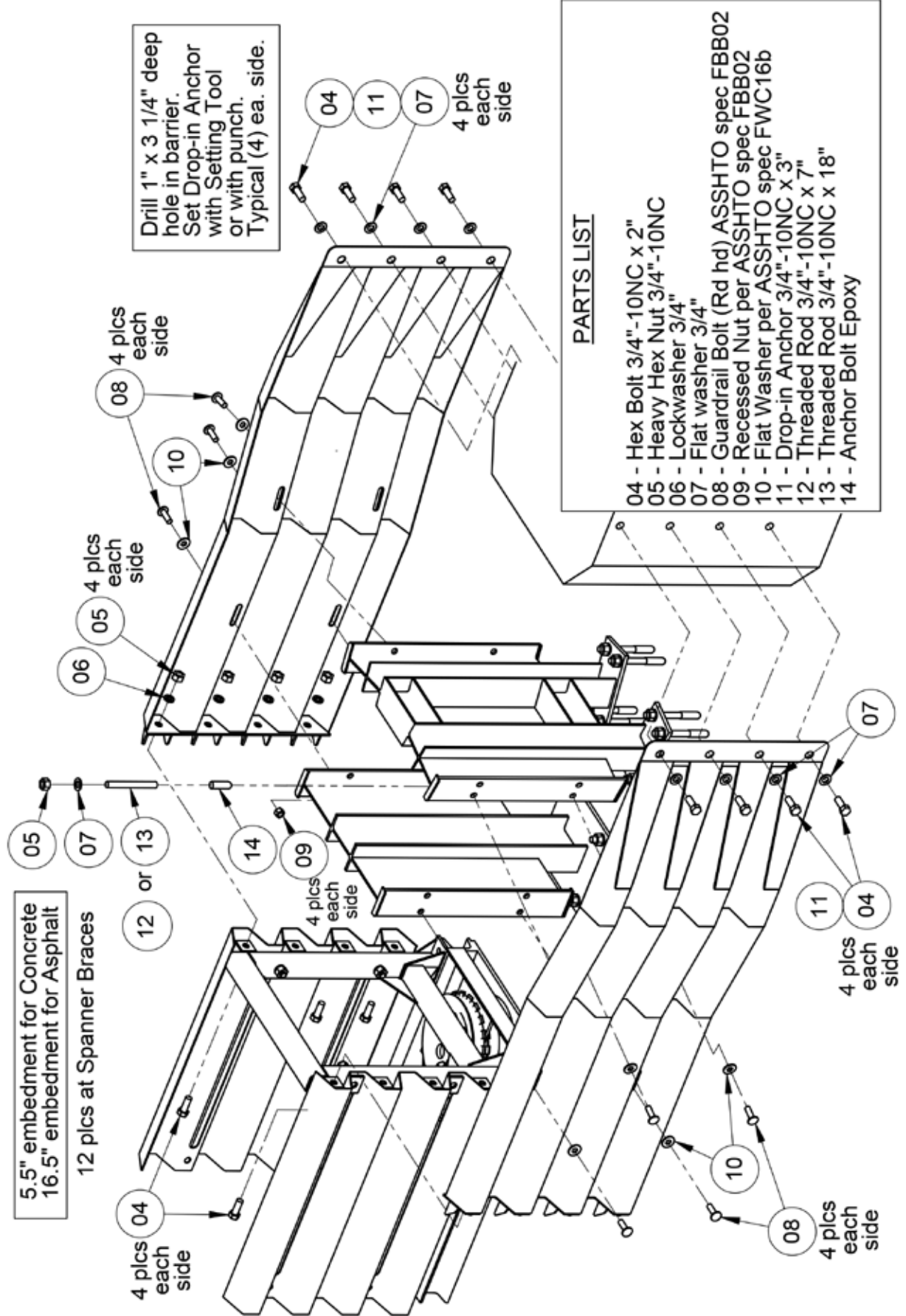

APPENDIX L - TRANSITION, CONCRETE BLOCK, 36 INCH (915mm) FLARED

Parts List:

- Two-Sided Full Assembly #275282
- 01 - Transition 36" Concrete Outside Connection #275268
- 02 - Transition Concrete Spanner Brace #275291
- 03 - Transition Concrete #1 Tapered Spanner Brace #275290
- 04 - Transition Concrete #2 Tapered Spanner Brace #233450

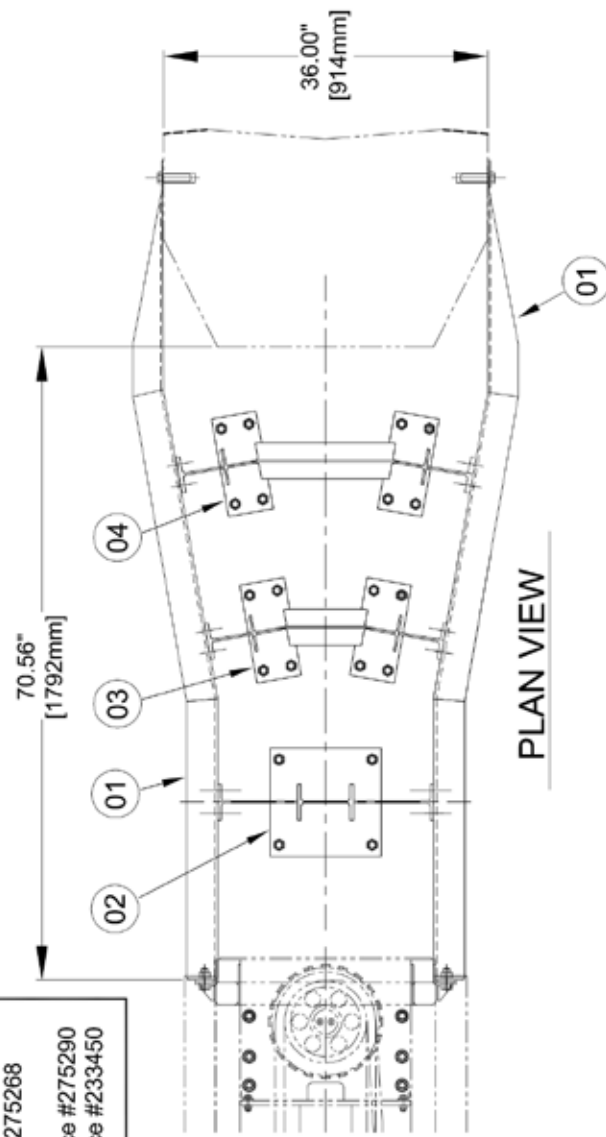

PLAN VIEW

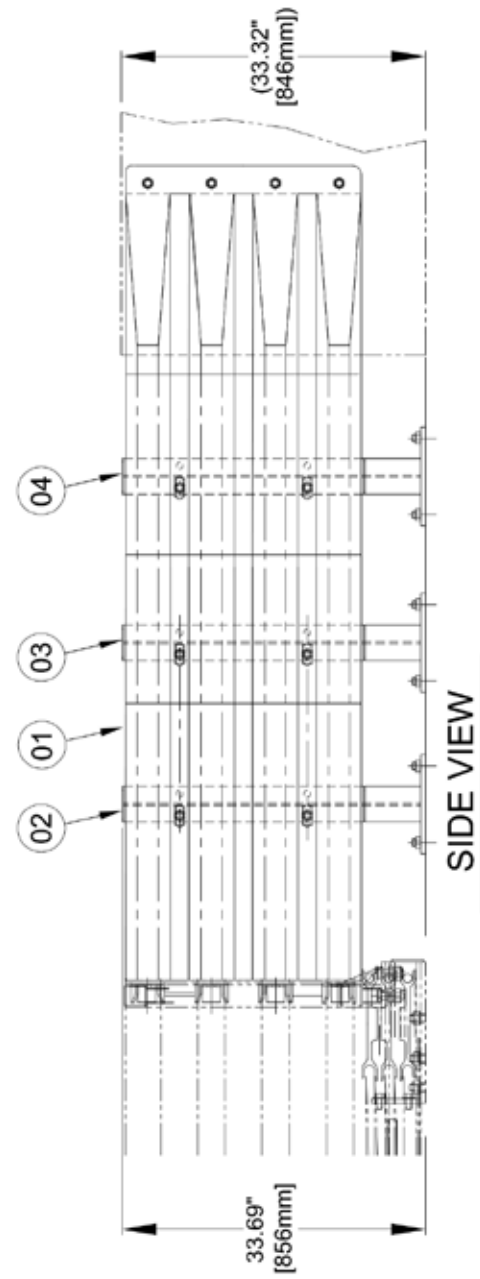

SIDE VIEW

APPENDIX L(2) - TRANSITION, CONCRETE BLOCK, 36 INCH (915mm) FLARED

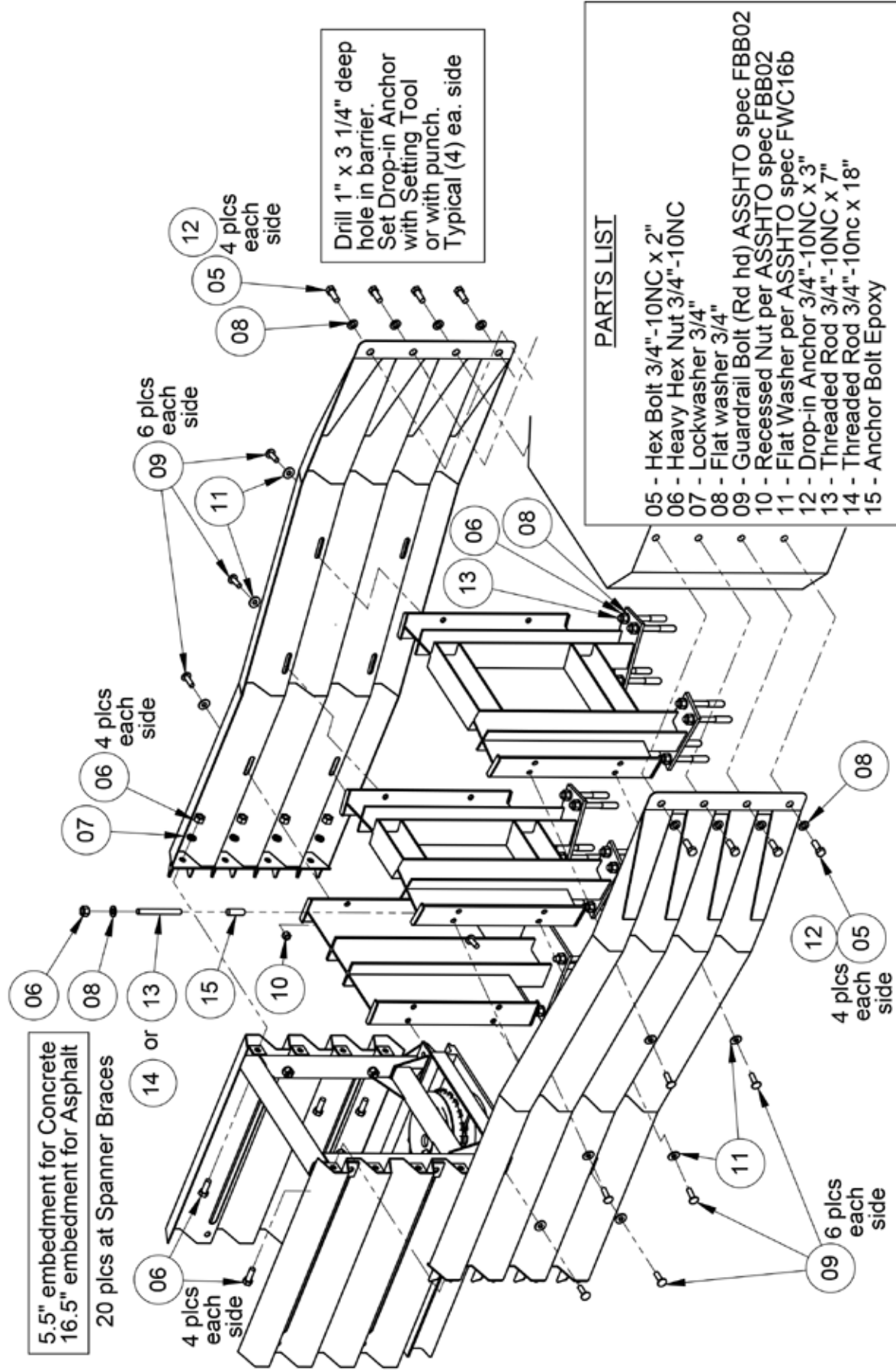

**APPENDIX M - TRANSITION TO THRIE BEAM
** FOR USE WITH BIDIRECTIONAL TRAFFIC**

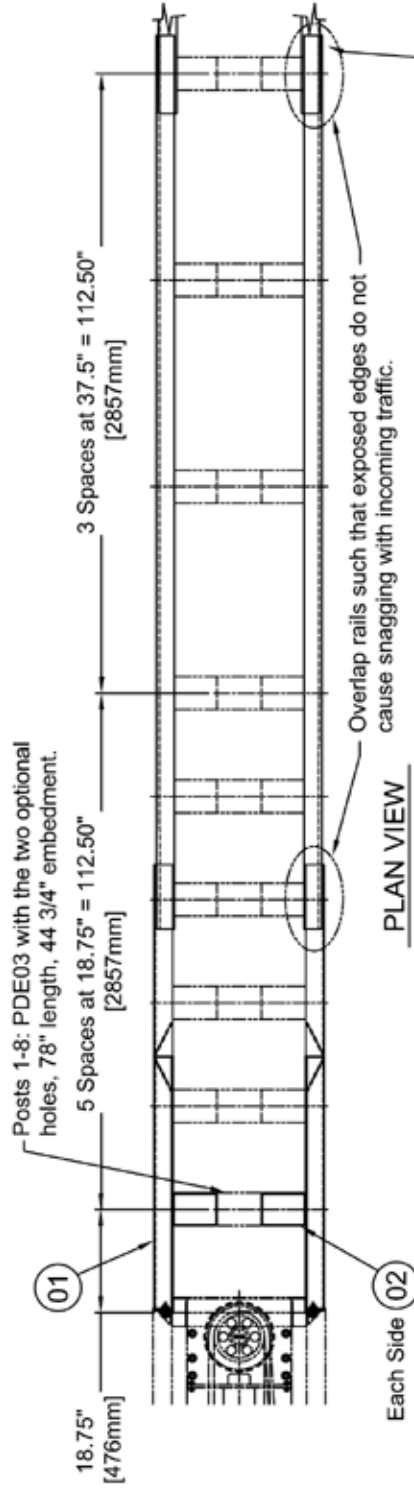

******THIS DESIGN IS FOR BIDIRECTIONAL TRAFFIC
POST SPACING AND NESTED GUARDRAIL PER SPEC.*****

*****GUARDRAILS, POSTS, BLOCKOUTS
AND CONNECTION BOLTS BY OTHERS.*****

- Parts List:
 01 - Transition Thrie & W Beam - Right #275298
 01 - Transition Thrie & W Beam - Left #232971
 02 - Rectangular Tube Blockout #265580

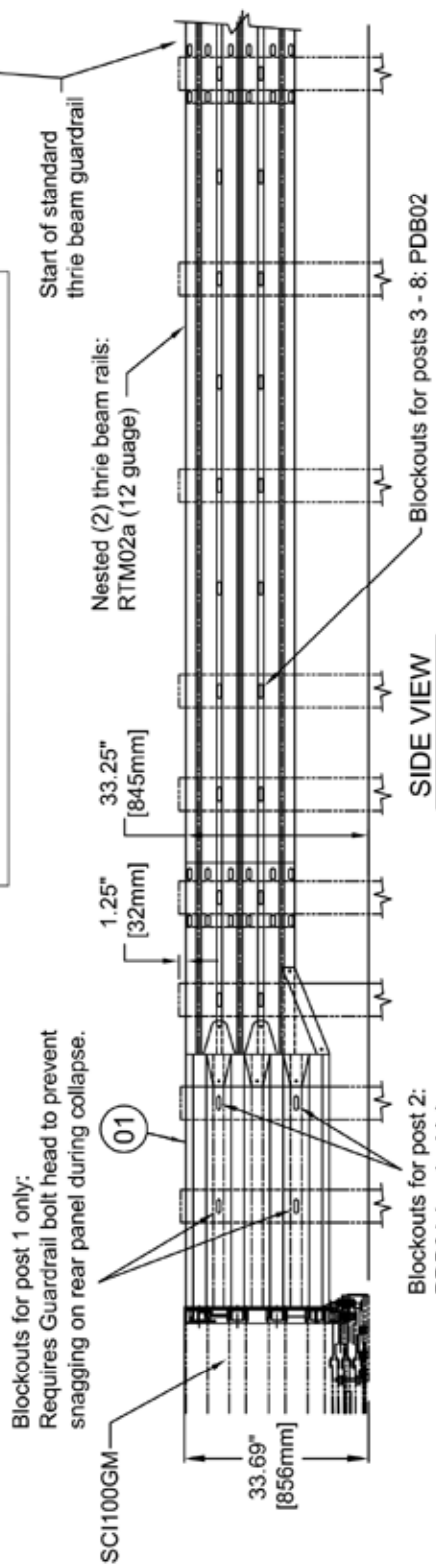

Blockouts for post 2:
 PDB01 (each side),
 or use similar to Part 15
 (figure 7) in original design.

SIDE VIEW

**APPENDIX M(2) - TRANSITION TO THRIE BEAM
 ** FOR USE WITH BIDIRECTIONAL TRAFFIC**

***THIS DESIGN IS FOR BIDIRECTIONAL TRAFFIC.
 POST SPACING AND NESTED GUARDRAIL PER SPEC.

***GUARDRAILS, POSTS, BLOCKOUTS AND
 CONNECTION BOLTS BY OTHERS.***

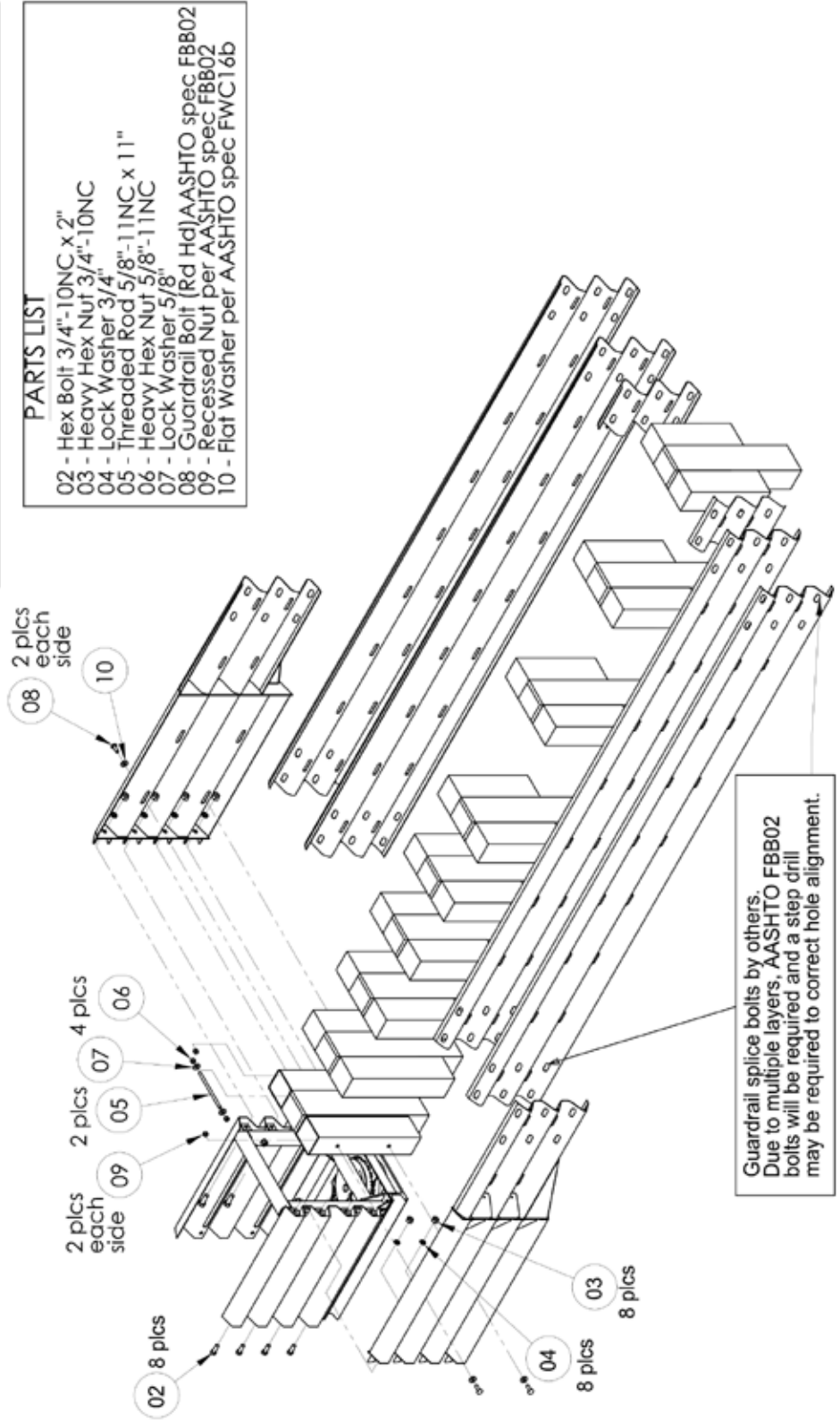

**APPENDIX N - TRANSITION TO W BEAM
** FOR USE WITH BIDIRECTIONAL TRAFFIC**

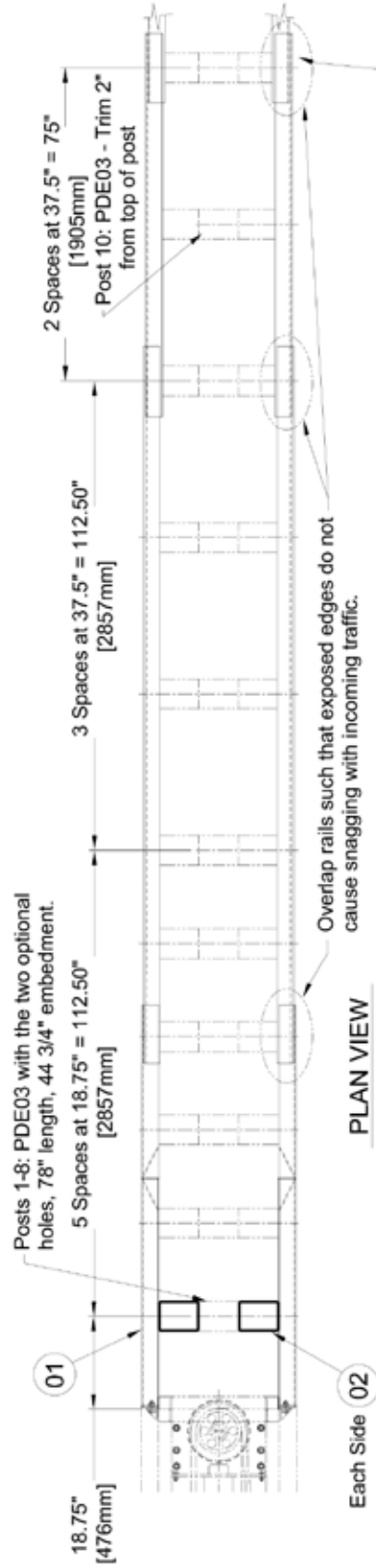

******THIS DESIGN IS FOR BIDIRECTIONAL TRAFFIC PATTERNS
POST SPACING AND NESTED GUARDRAIL PER SPEC. ******

*****GUARDRAIL, POSTS, BLOCKOUTS AND
CONNECTION BOLTS BY OTHERS.*****

- Parts List:
 01 - Transition Thrie & W Beam - Right #275298
 01 - Transition Thrie & W Beam - Left #232971
 02 - Rectangular Tube Blockout #265580

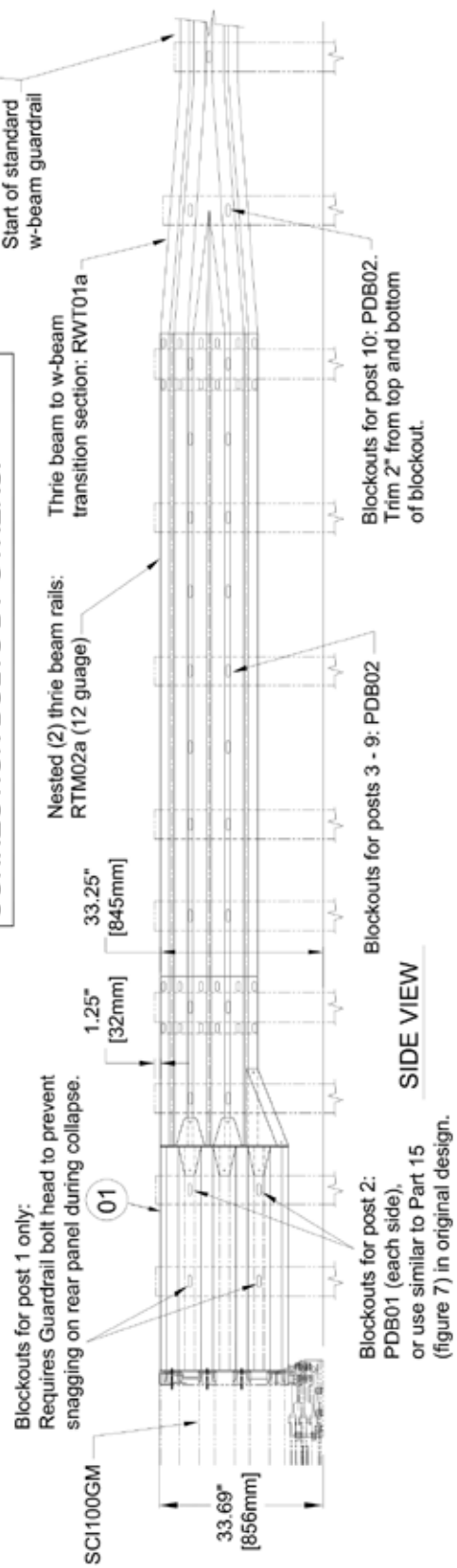

Blockouts for post 2:
 PDB01 (each side),
 or use similar to Part 15
 (figure 7) in original design.

SIDE VIEW

Blockouts for posts 3 - 9: PDB02

Blockouts for post 10: PDB02.
 Trim 2" from top and bottom
 of blockout.

Start of standard
 w-beam guardrail

Thrie beam to w-beam
 transition section: RWT01a

Nested (2) thrie beam rails:
 RTM02a (12 gauge)

Blockouts for post 1 only:
 Requires Guardrail bolt head to prevent
 snagging on rear panel during collapse.

Overlap rails such that exposed edges do not
 cause snagging with incoming traffic.

**APPENDIX N(2) - TRANSITION TO W BEAM
 ** FOR USE WITH BIDIRECTIONAL TRAFFIC**

***THIS DESIGN IS FOR BIDIRECTIONAL TRAFFIC.
 POST SPACING AND NESTED GUARDRAIL PER SPEC.

***GUARDRAILS, POSTS, BLOCKOUTS AND
 CONNECTION BOLTS BY OTHERS.***

PARTS LIST

- 02 - Hex Bolt 3/4"-10NC x 2"
- 03 - Heavy Hex Nut 3/4"-10NC
- 04 - Lock Washer 3/4"
- 05 - Threaded Rod 5/8"-11NC x 11"
- 06 - Heavy Hex Nut 5/8"-11NC
- 07 - Lock Washer 5/8"
- 08 - Guardrail Bolt (Rd Hd)AASHTO spec FBB02
- 09 - Recessed Nut per AASHTO spec FBB02
- 10 - Flat Washer per AASHTO spec FWC16b

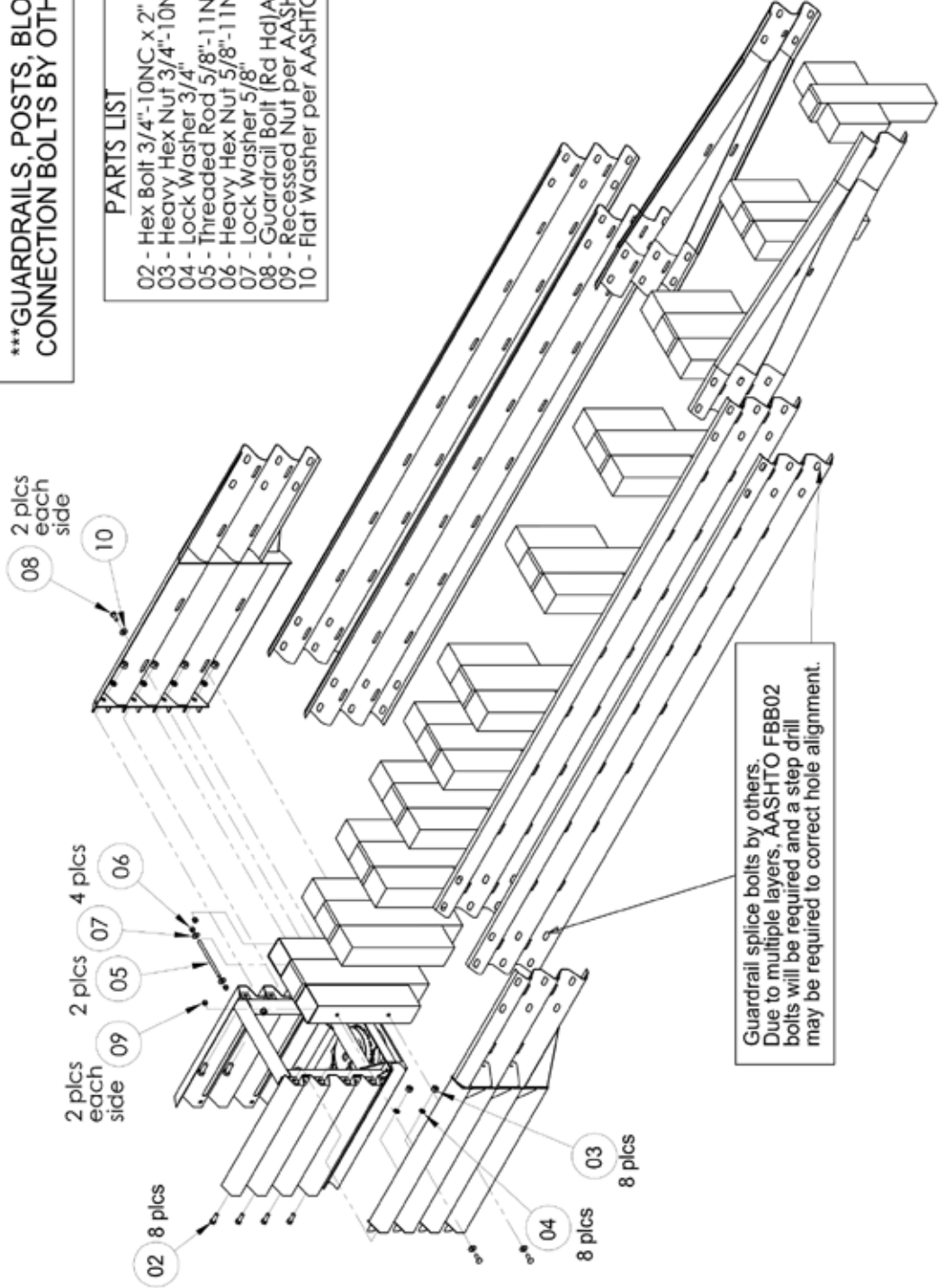

Guardrail splice bolts by others.
 Due to multiple layers, AASHTO FBB02
 bolts will be required and a step drill
 may be required to correct hole alignment.

APPENDIX O - TRANSITION, JERSEY/F SHAPE, VARIABLE WIDTH BASE

Parts List for Double Sided Median Barrier 30"-38" Base:

Two-Sided Full Assembly #239542 (with rub rail),
#239545 (without rub rail)

01 - Transition - Left #275272

02 - Transition - Right #275273

03 - Transition Rub Rail - Left #275270

04 - Transition Rub Rail - Right #275271

05 - Transition Support Bracket - Right #239471

06 - Transition Support Bracket - Left #239472

For use with barriers with base widths of 30"-38"
Rub rails only required for base widths > 34"

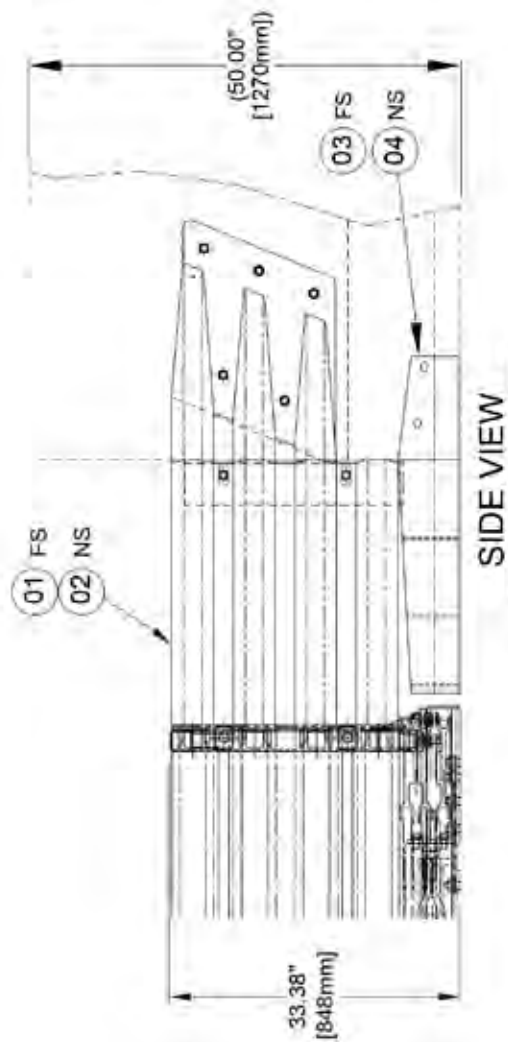
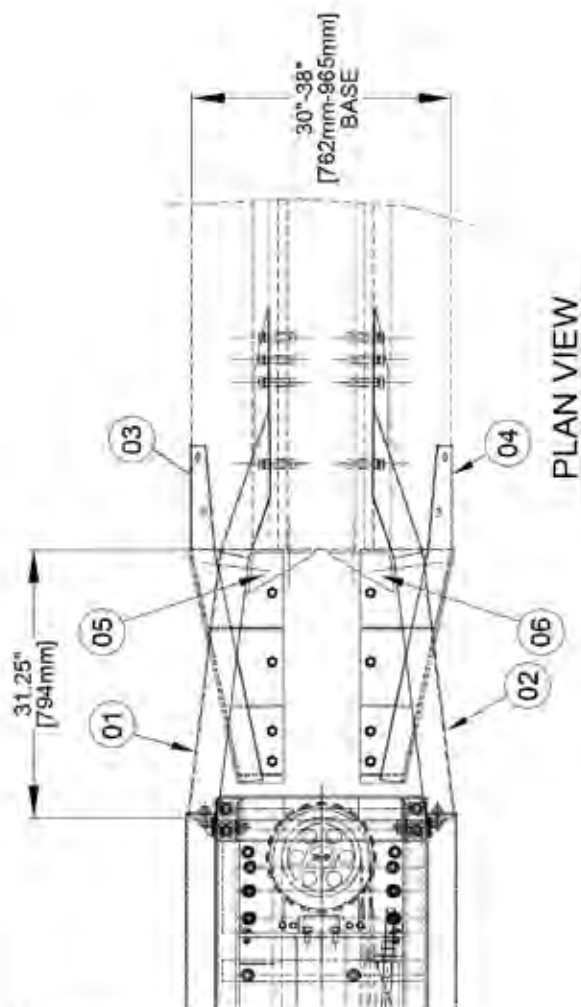

APPENDIX O(2) - TRANSITION, JERSEY/F SHAPE, VARIABLE WIDTH BASE

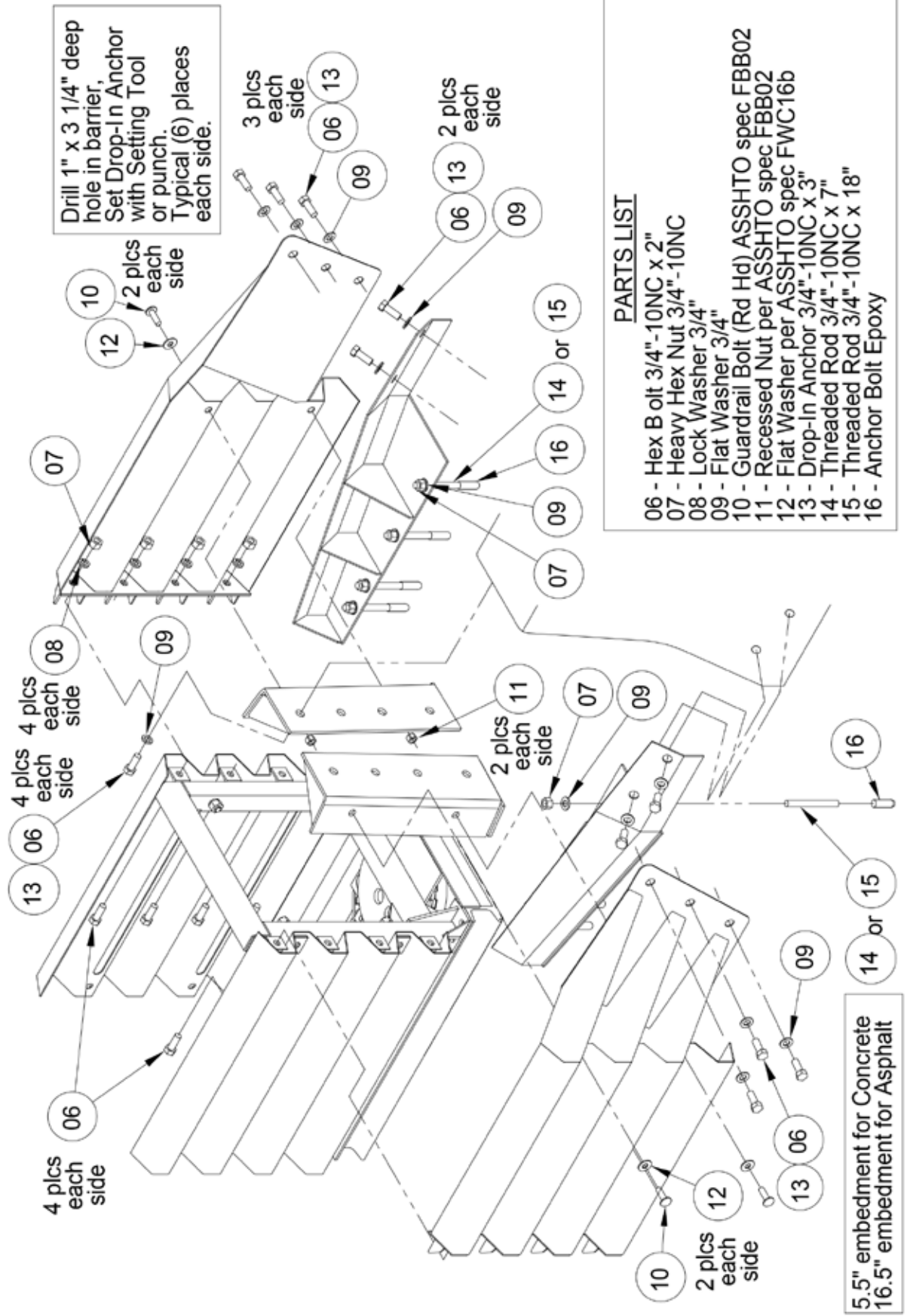

APPENDIX FIG P SINGLE SLOPE BARRIER

- Transition Single Slope Median Barrier - Right #275299 (shown)
- Transition Single Slope Median Barrier - Left #275302 (not shown)

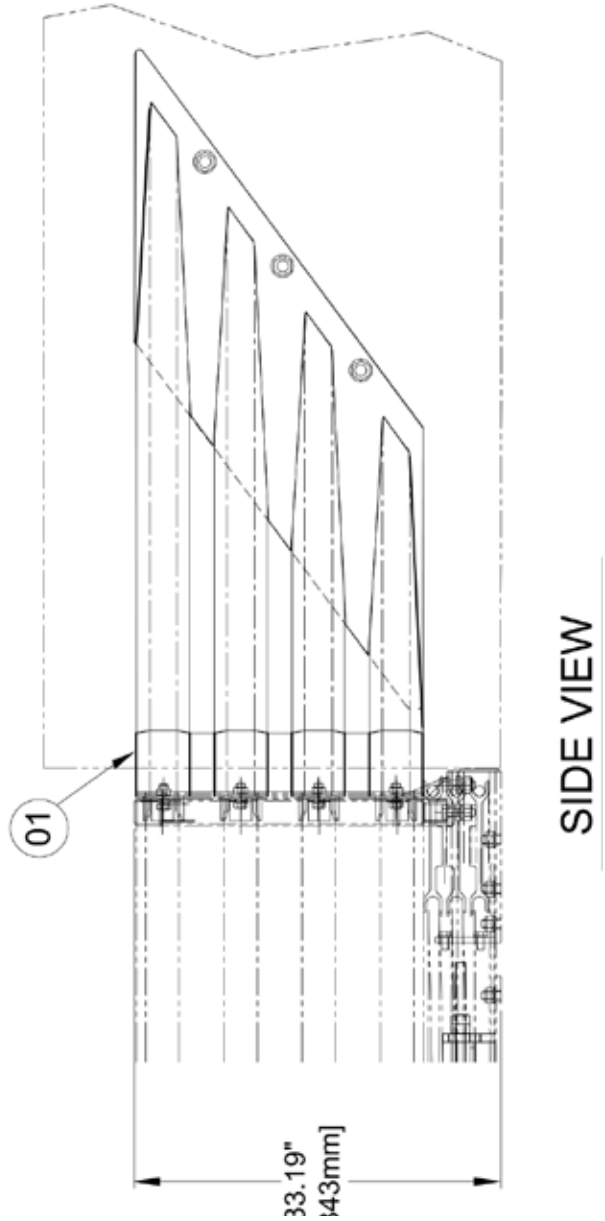
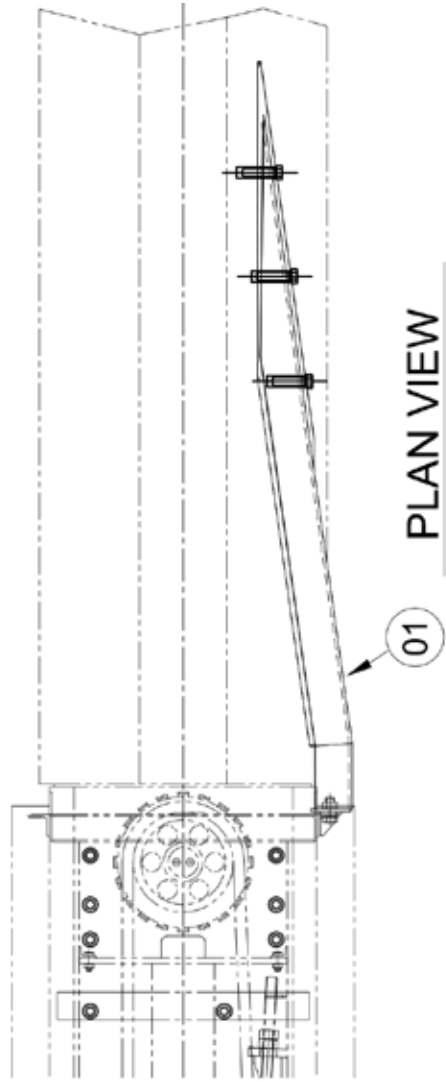

APPENDIX P(2) - TRANSITION, MEDIAN BARRIER - SINGLE SLOPE

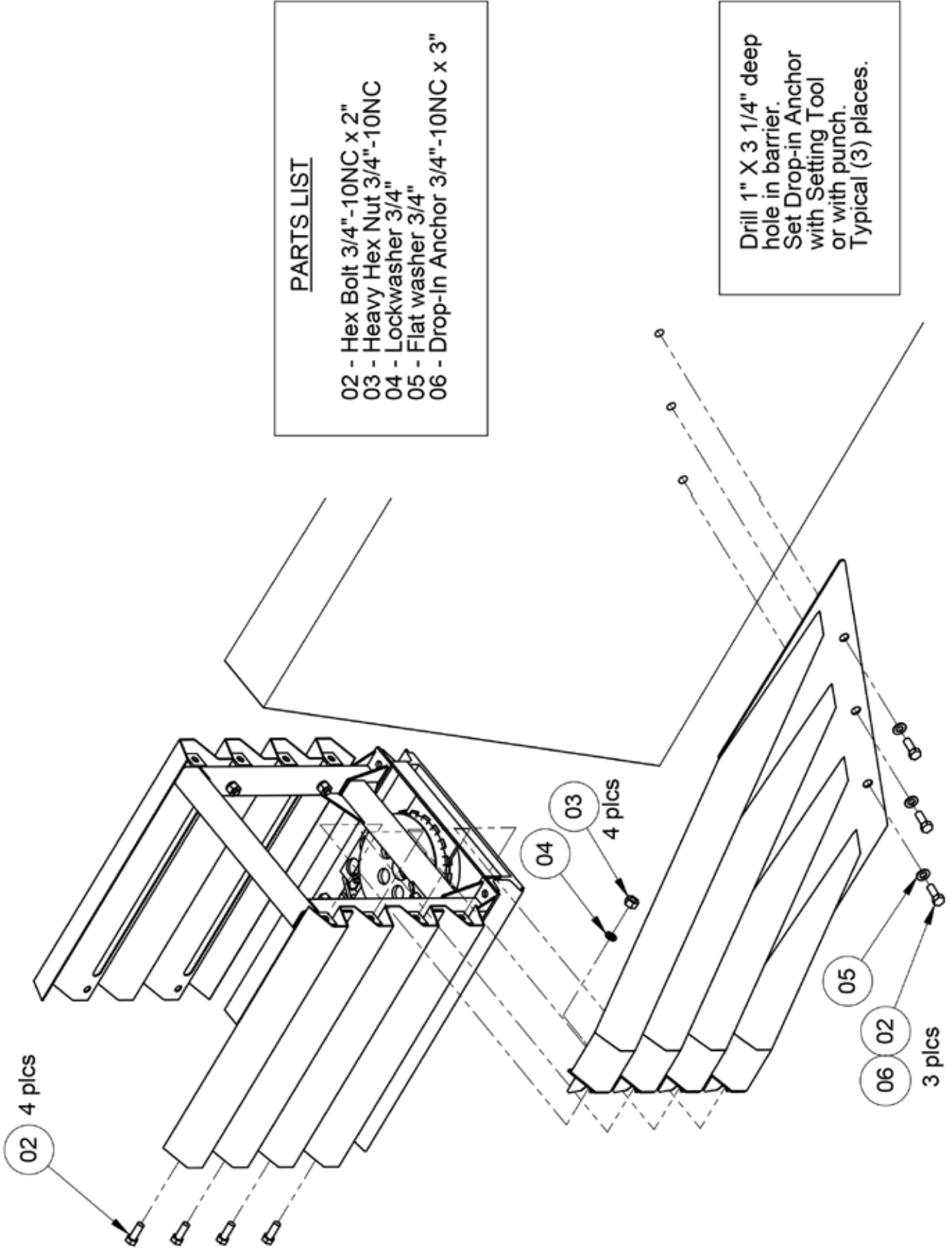

PARTS LIST

- 02 - Hex Bolt 3/4"-10NC x 2"
- 03 - Heavy Hex Nut 3/4"-10NC
- 04 - Lockwasher 3/4"
- 05 - Flat washer 3/4"
- 06 - Drop-In Anchor 3/4"-10NC x 3"

Drill 1" X 3 1/4" deep hole in barrier. Set Drop-in Anchor with Setting Tool or with punch. Typical (3) places.

APPENDIX Q - TRANSITION, W BEAM 28" HIGH
***** Unidirectional Traffic Only**

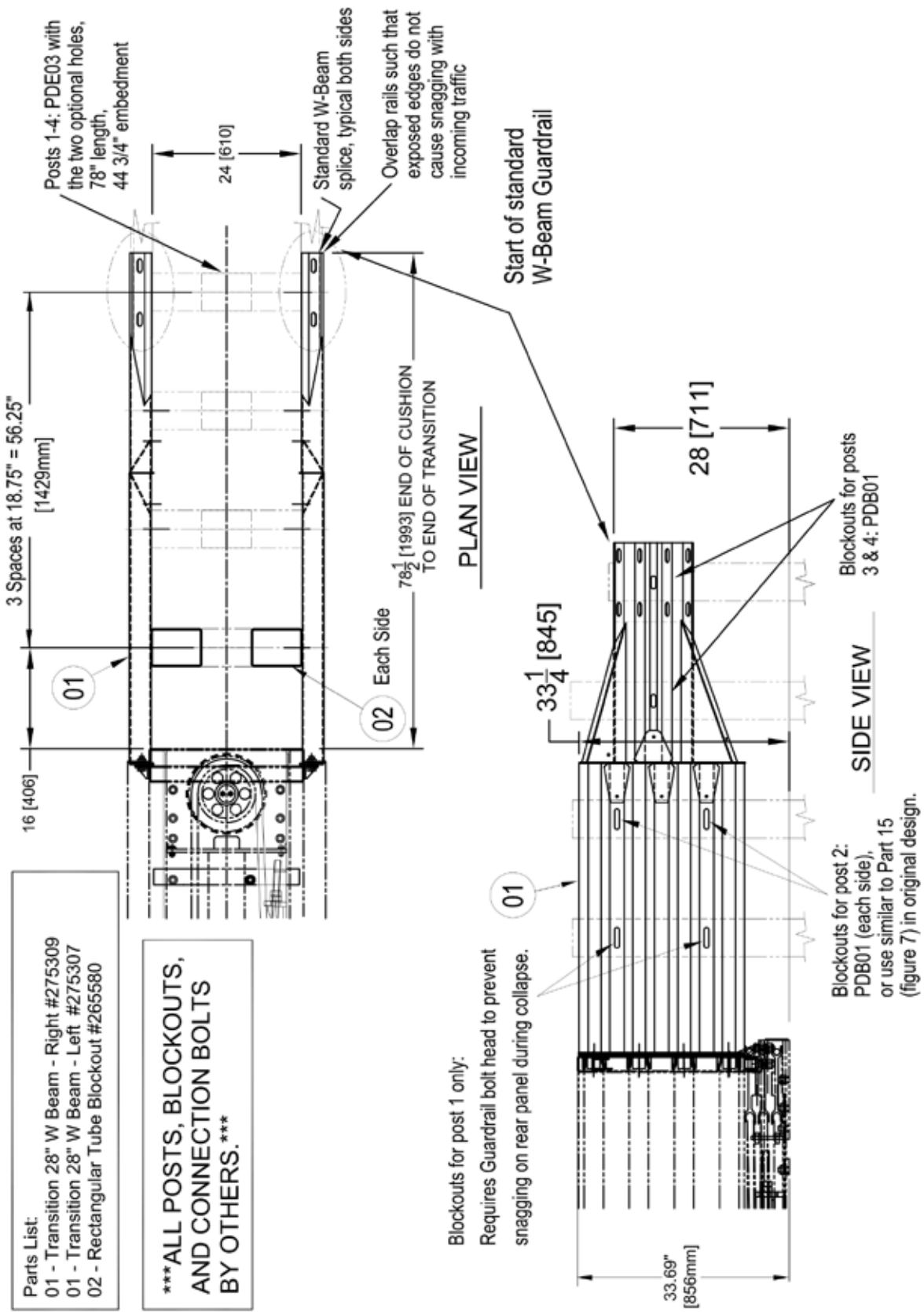

Parts List:
 01 - Transition 28" W Beam - Right #275309
 01 - Transition 28" W Beam - Left #275307
 02 - Rectangular Tube Blockout #265580

*****ALL POSTS, BLOCKOUTS, AND CONNECTION BOLTS BY OTHERS.*****

APPENDIX Q(2) & R(2) - TRANSITION, W BEAM 28" & 32" HIGH

PARTS LIST

- 02 - Hex Bolt 3/4"-10NC x 2"
- 03 - Heavy Hex Nut 3/4"-10NC
- 04 - Lock Washer 3/4"
- 05 - Threaded Rod 5/8"-11NC x 11"
- 06 - Heavy Hex Nut 5/8"-11NC
- 07 - Lock Washer 5/8"
- 08 - Guardrail Bolt (Rd Hd)AASHTO spec FBB02
- 09 - Recessed Nut per AASHTO spec FBB02
- 10 - Flat Washer per AASHTO spec FWC16b

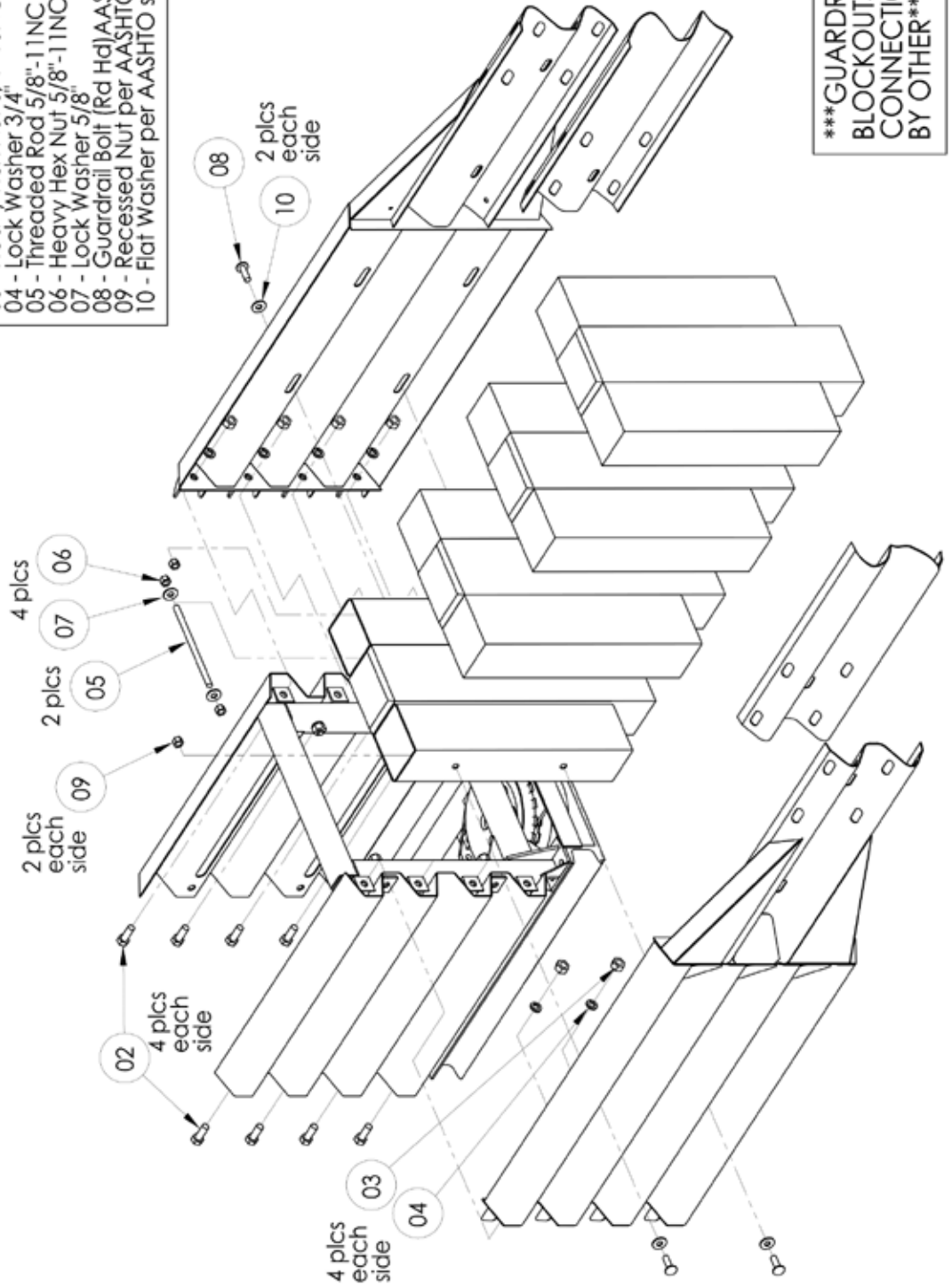

*****GUARDRAILS, POSTS,
BLOCKOUTS AND
CONNECTION BOLTS
BY OTHER*****

APPENDIX R - TRANSITION, W BEAM 32" HIGH
**** Unidirectional Traffic Only**

Parts List:
 01 - Transition 32" W Beam - Right #275311
 01 - Transition 32" W Beam - Left #275310
 02 - Rectangular Tube Blockout #265580

***** ALL POSTS, BLOCKOUTS AND CONNECTION BOLTS SUPPLIED BY OTHERS. *****

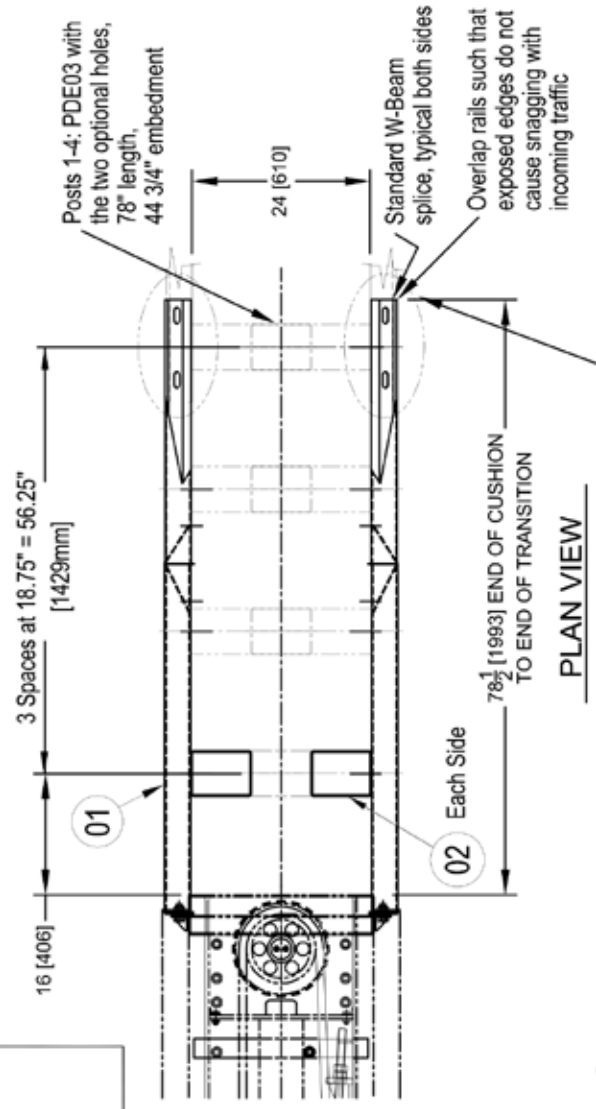

Blockouts for post 1 only:
 Requires Guardrail bolt head to prevent snagging on rear panel during collapse.

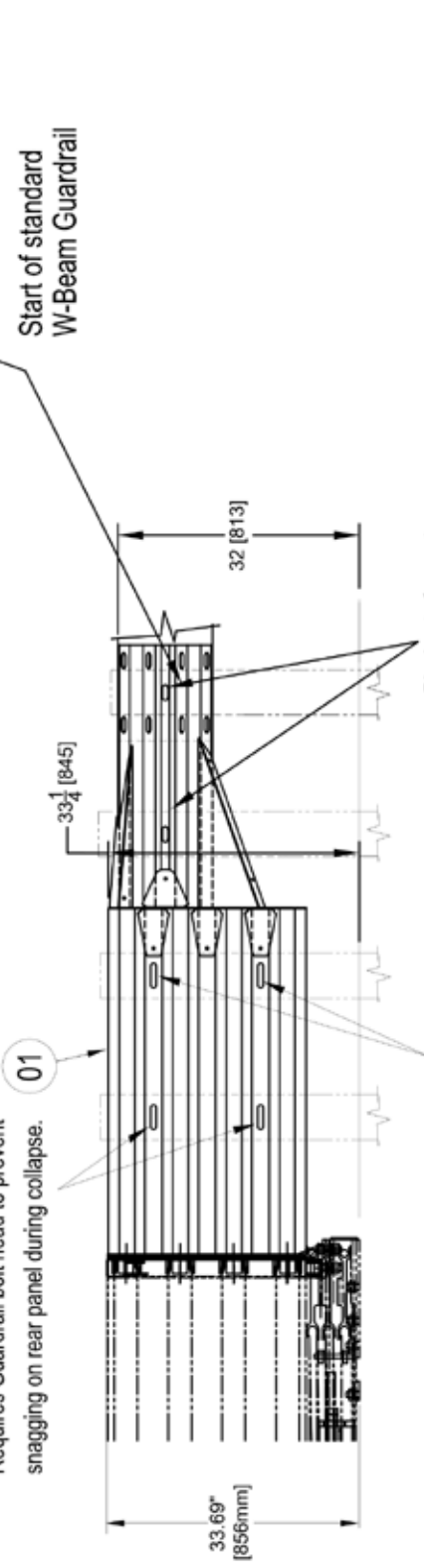

Blockouts for post 2: PDB01 (each side), or use similar to Part 15 (figure 7) in original design.

Blockouts for posts 3 & 4: PDB01

APPENDIX S - TRANSITION, SPANNER FOR CONCRETE BLOCK

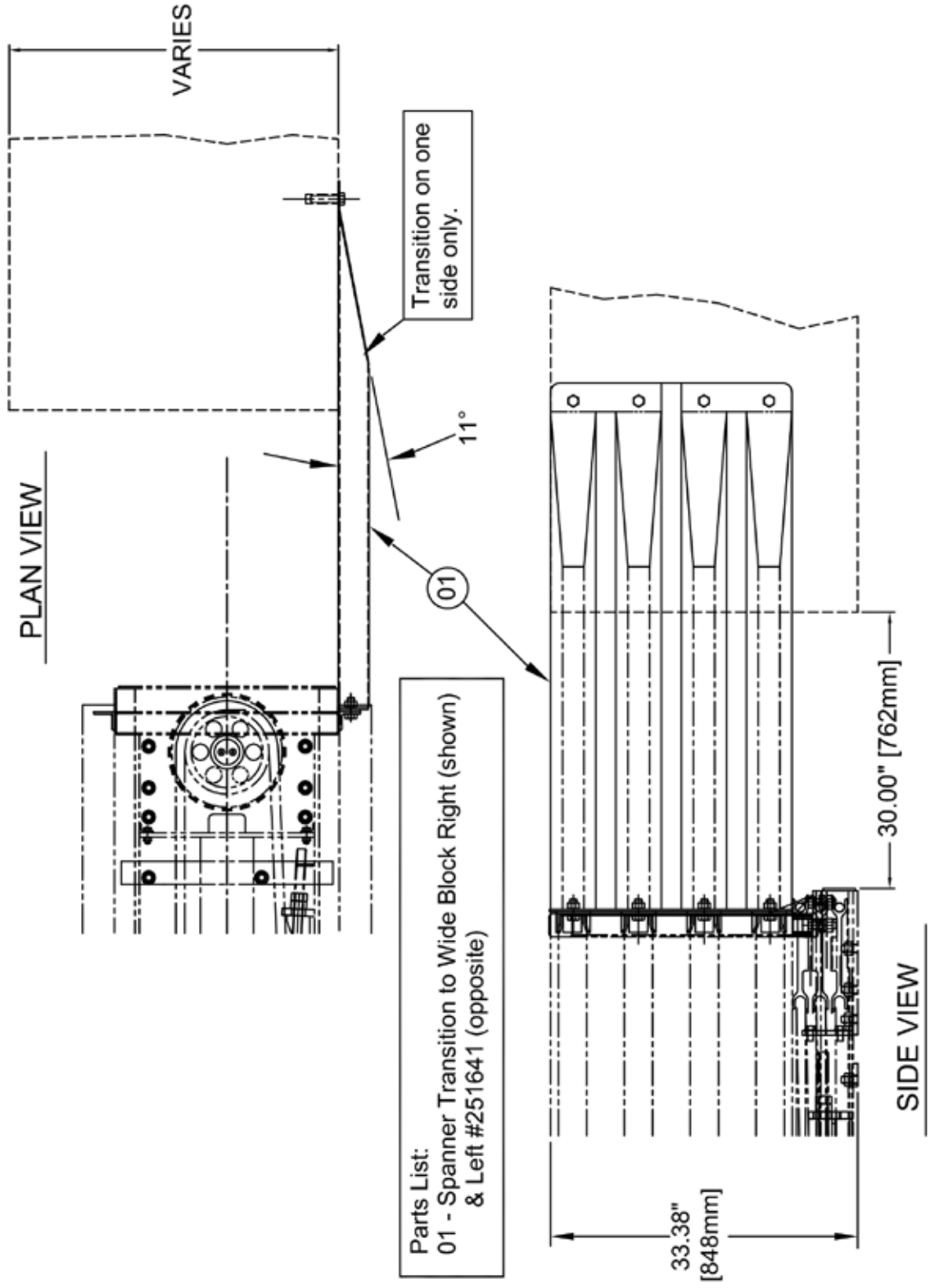

APPENDIX FIG S-2 SPANNER 06-50

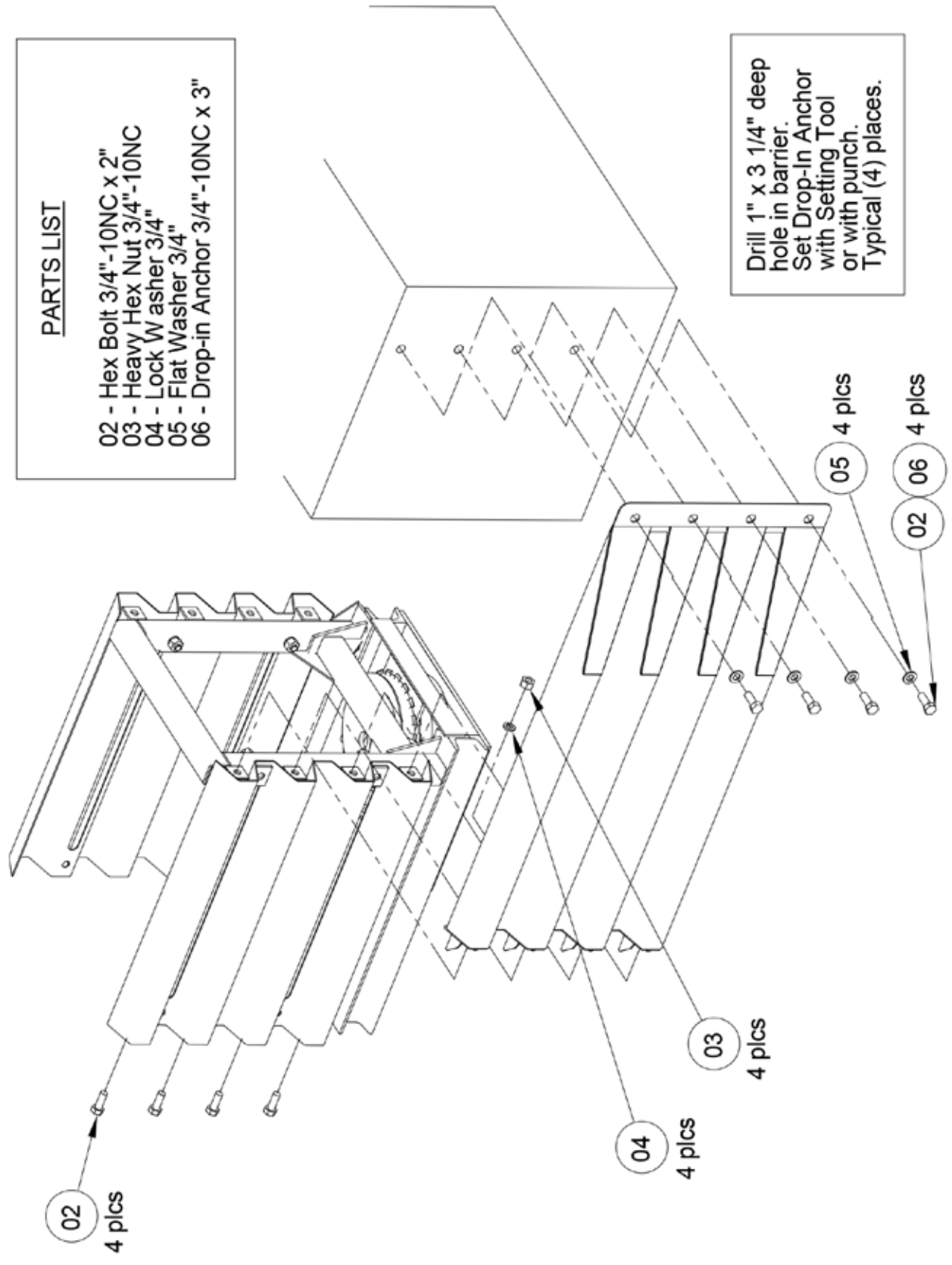

- PARTS LIST**
- 02 - Hex Bolt 3/4" -10NC x 2"
 - 03 - Heavy Hex Nut 3/4" -10NC
 - 04 - Lock Washer 3/4"
 - 05 - Flat Washer 3/4"
 - 06 - Drop-in Anchor 3/4" -10NC x 3"

Drill 1" x 3 1/4" deep hole in barrier.
 Set Drop-In Anchor with Setting Tool or with punch.
 Typical (4) places.

APPENDIX T - TRANSITION, OFFSET CONCRETE BLOCK

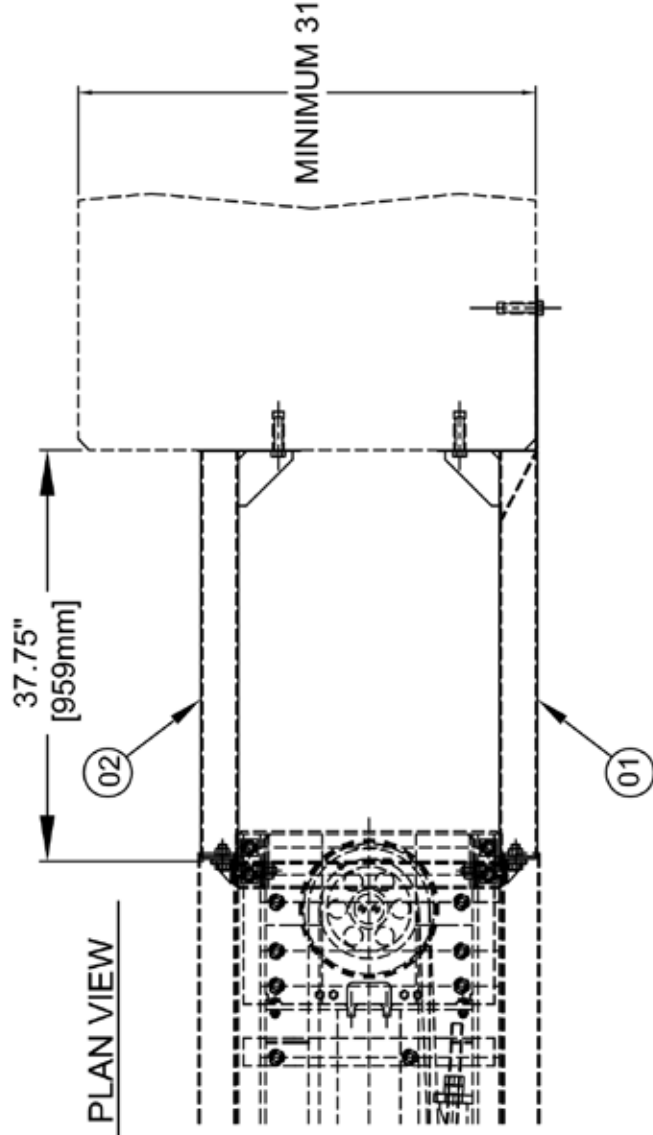

- Parts List:
 01 - Straight Panel #275265
 02 - Offset Panel #255878

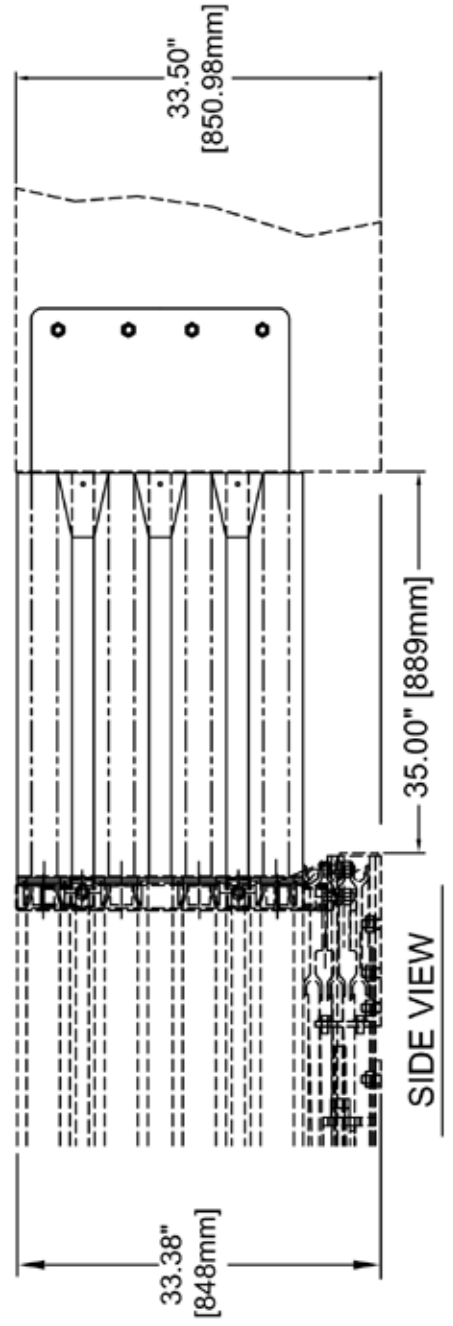

APPENDIX T(2) - TRANSITION, OFFSET CONCRETE BLOCK

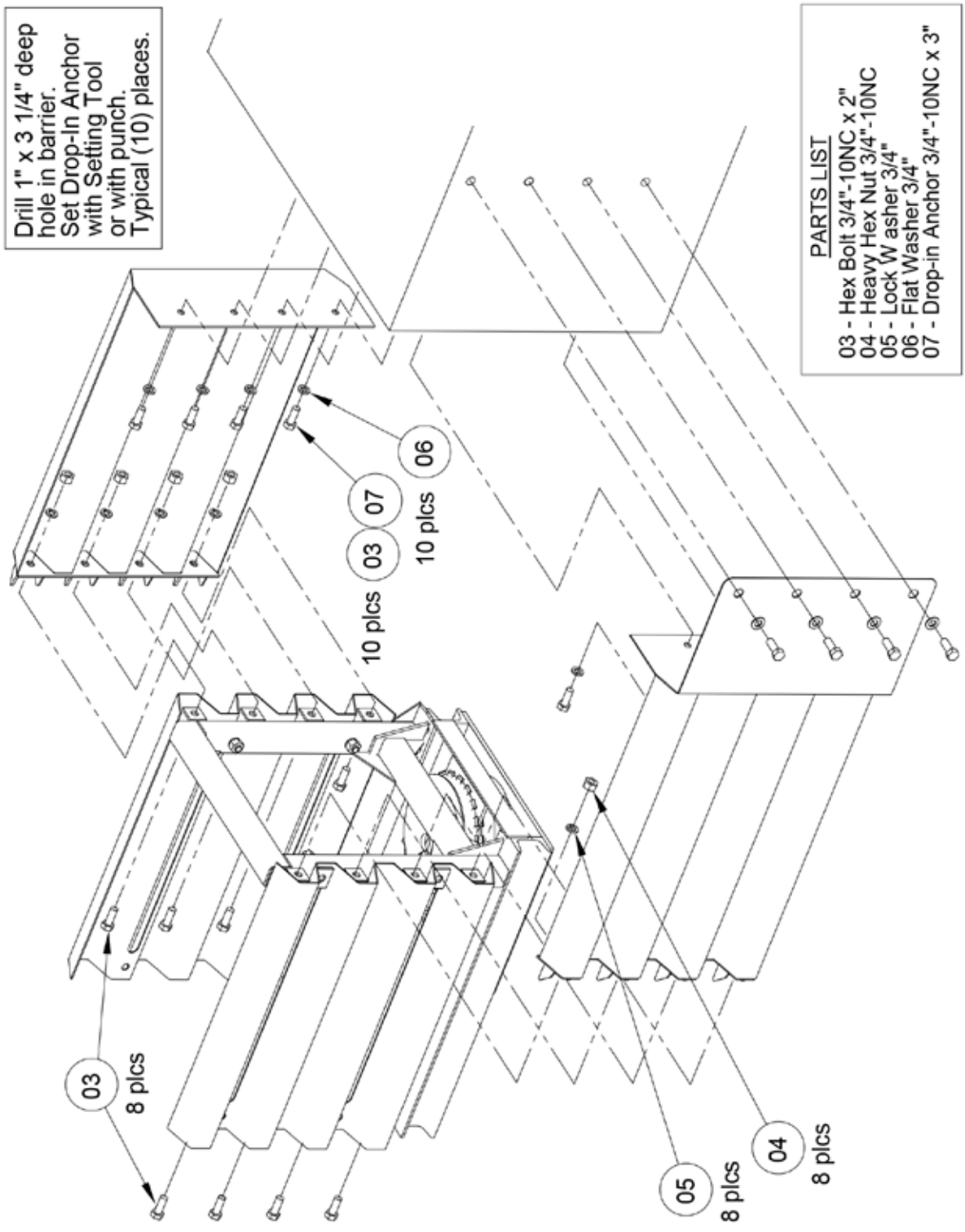

- PARTS LIST**
- 03 - Hex Bolt 3/4"-10NC x 2"
 - 04 - Heavy Hex Nut 3/4"-10NC
 - 05 - Lock Washer 3/4"
 - 06 - Flat Washer 3/4"
 - 07 - Drop-in Anchor 3/4"-10NC x 3"

APPENDIX U - TRANSITION, CONCRETE BLOCK, 36-44 INCH (914-1118 mm)

BARRIER WIDTH	ASSEMBLY PART NO	PANEL ET-06-38 PART NO (ITEM 01)	STEEL POST ET-06-22 PART NO (ITEM 2)	LENGTH 'A'
	JDE	JDE	JDE	
36"	254620	254952	275291	43"
38"	254621	254953	275291	48 1/2"
40"	254622	254954	275291	54 1/4"
42"	254623	254955	275291	60"
44"	254624	254956	275291	65 3/4"

PLAN VIEW

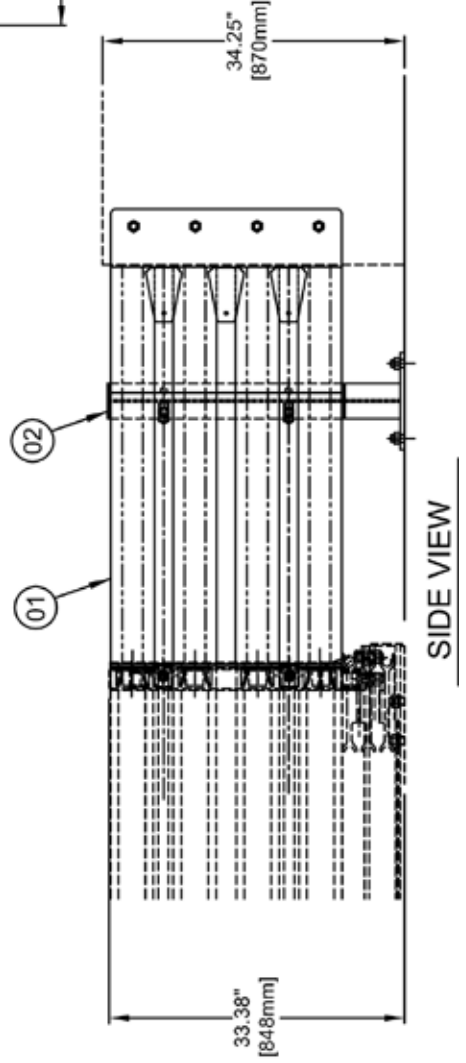
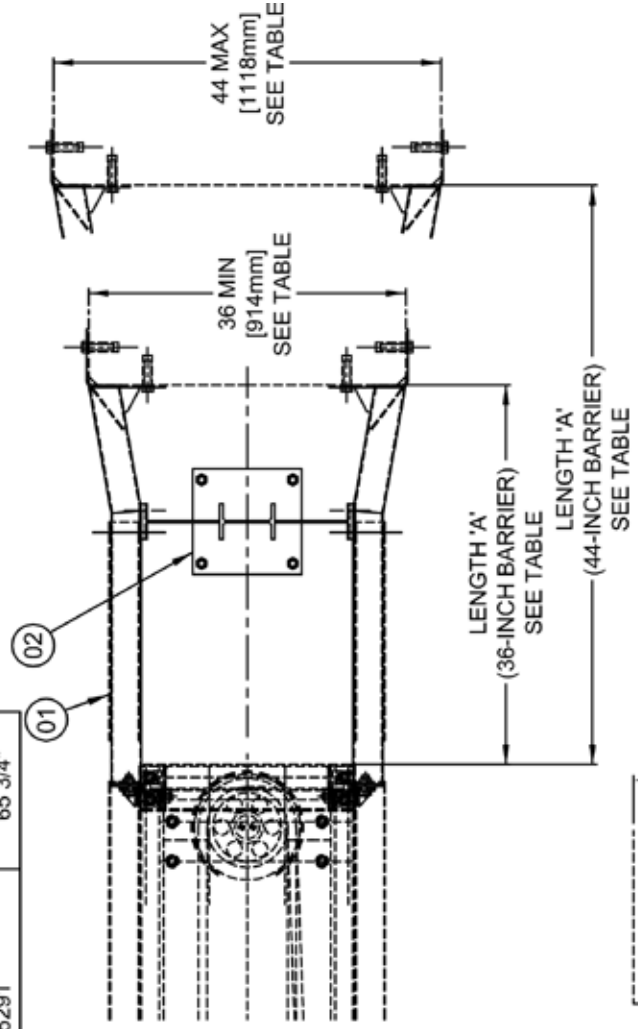

APPENDIX U(2) - TRANSITION, CONCRETE BLOCK, 36-44 INCH (914-1118 mm)

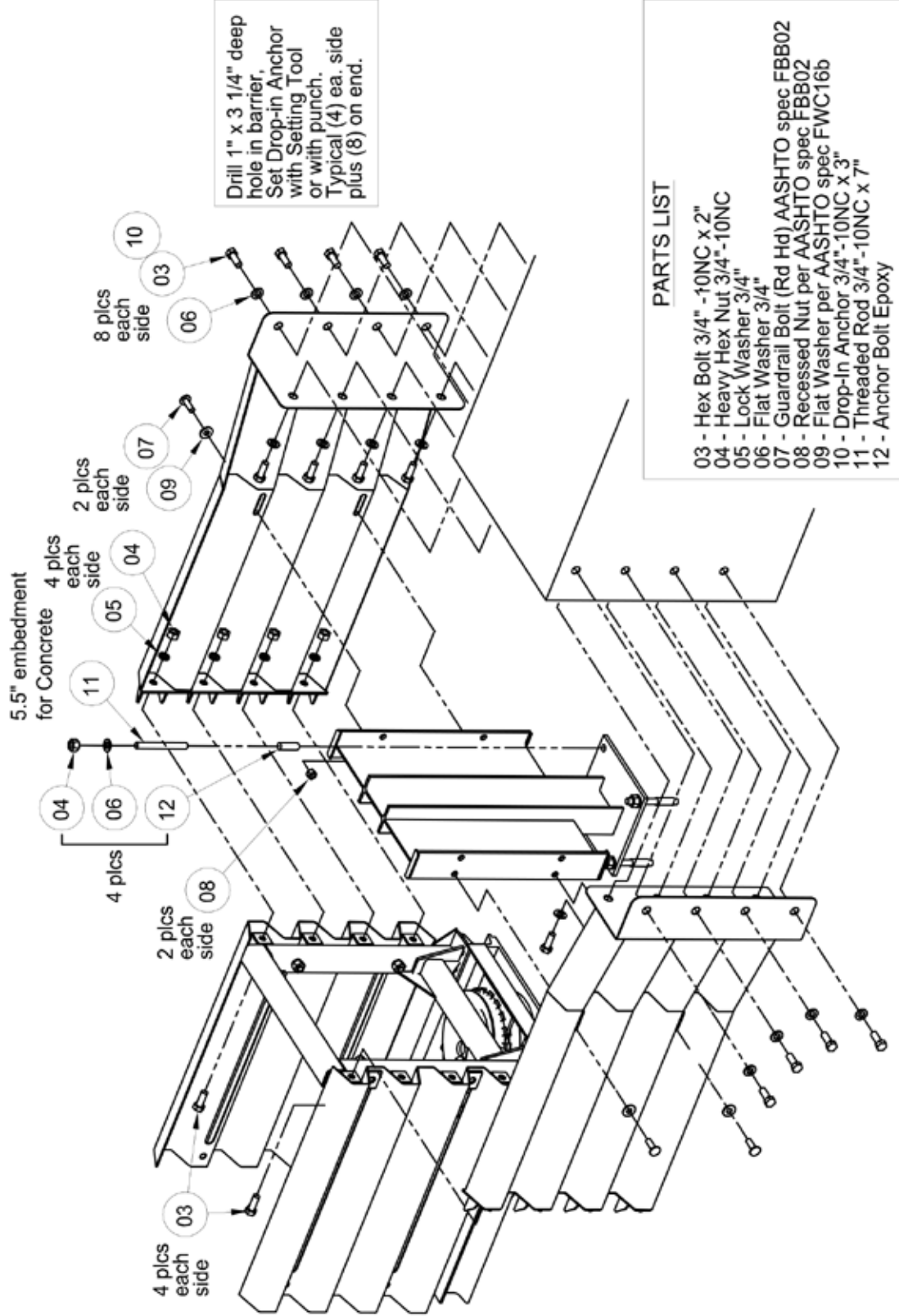

APPENDIX V - TRANSITION, CONCRETE BLOCK, 46-48 INCH (1168-1219 mm)

BARRIER WIDTH	BARRIER WIDTH JDE	PANEL (RIGHT) PART NO (ITEM 01) JDE	PANEL (LEFT) PART NO (ITEM 01) JDE	END SHOE PART NO (ITEM 02) JDE	STEEL POST PART NO (ITEM 03) JDE	TAPERED POST PART NO (ITEM 04) JDE	LENGTH 'A'
46"	254625	254959	254960	255431	275291	275292	70 3/4"
48"	254626	254959	254960	255432	275291	275292	76 1/4"

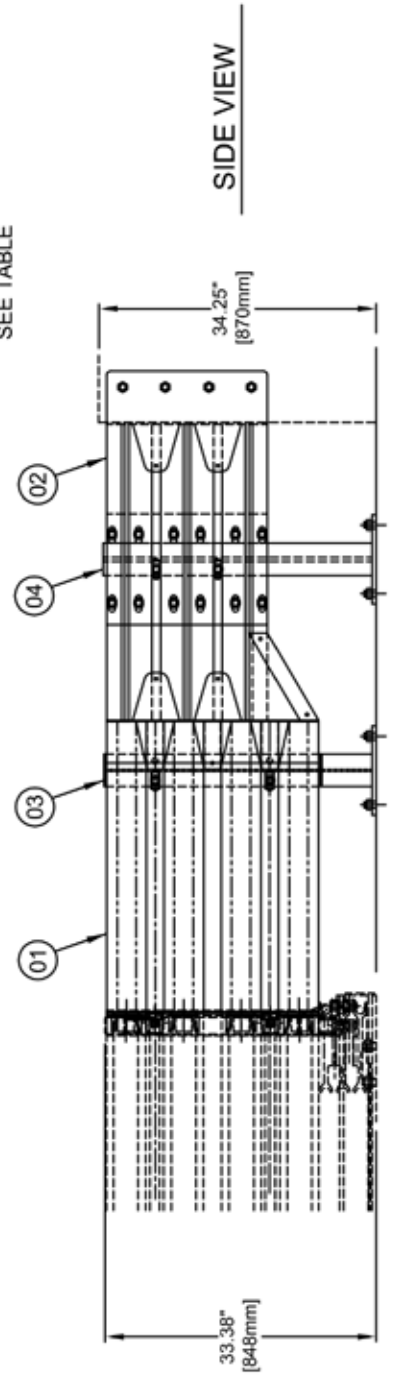
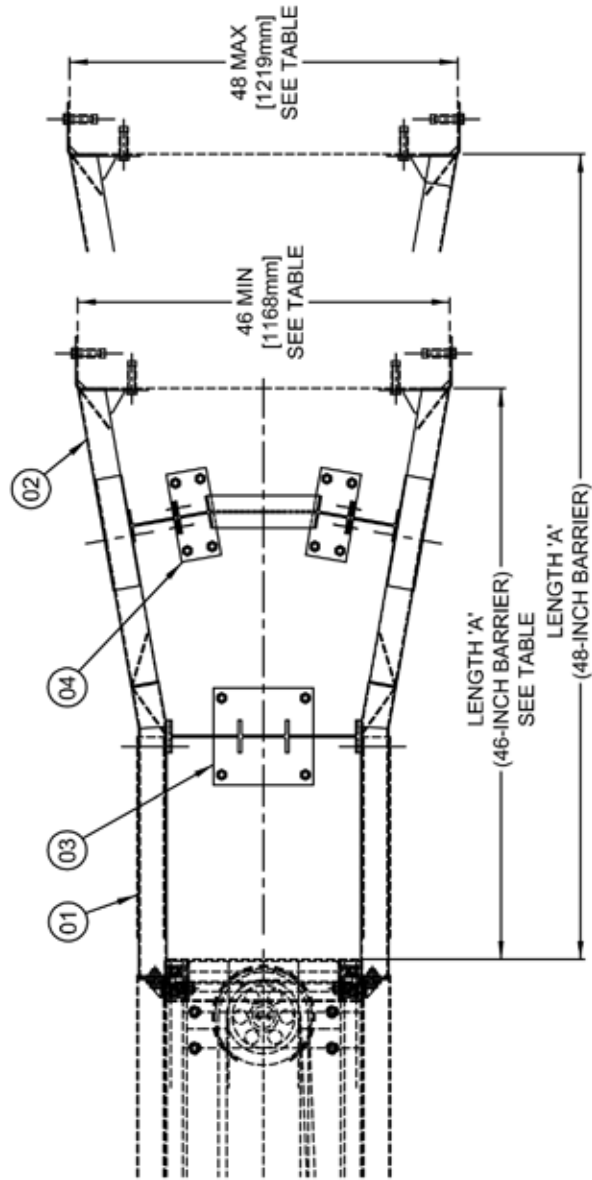

APPENDIX V(2) - TRANSITION, CONCRETE BLOCK, 46-48 INCH (1168-1219 mm)

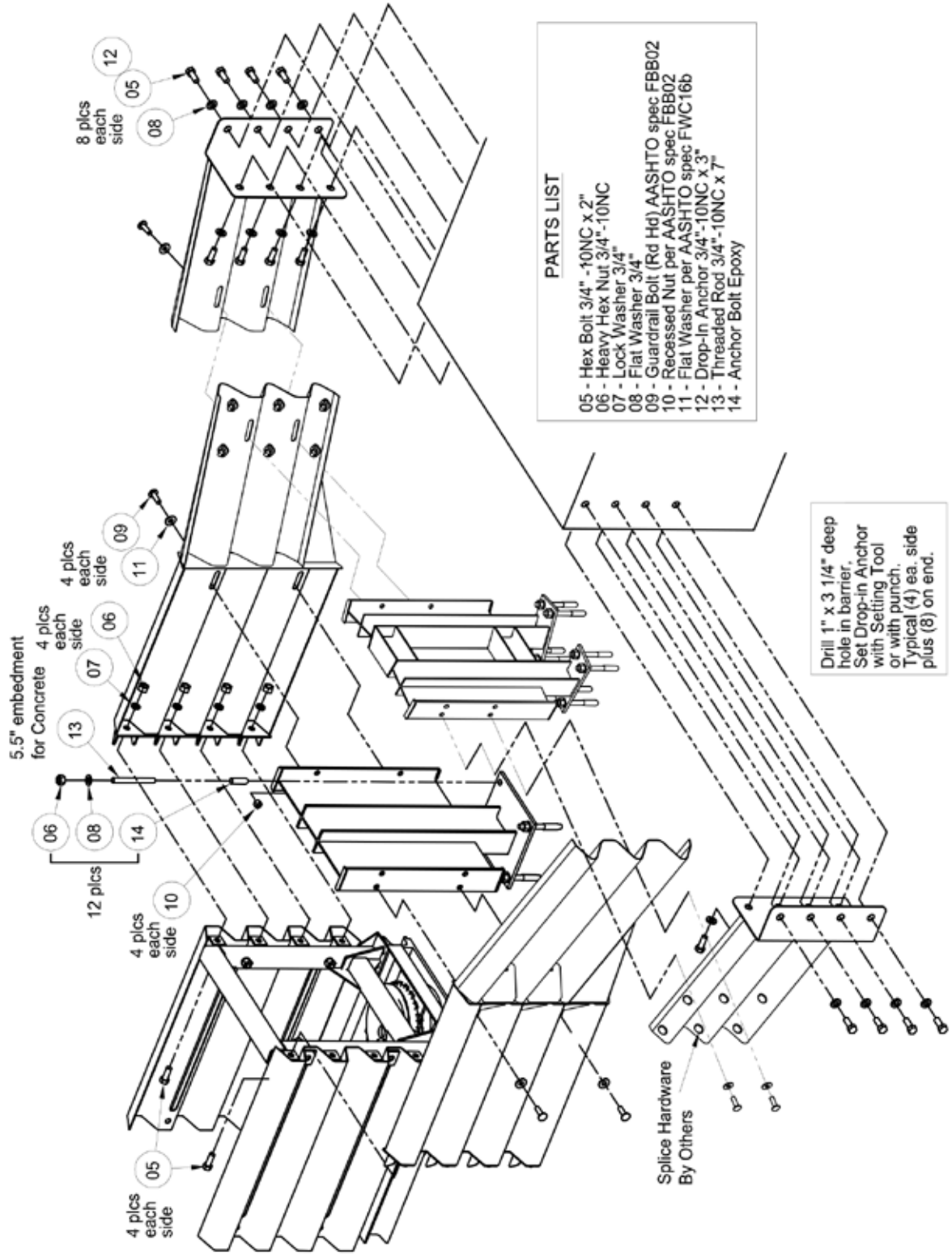



W O R K A R E A P R O T E C T I O N

SCI70/100GM CRASH CUSHION COMMERCIAL 1-YEAR WARRANTY

SCI PRODUCTS INC. warrants this product to be free from defects in material and workmanship under normal use and service for a period of one (1) year beginning on the date of installation. SCI PRODUCTS INC. will repair or replace without charge to the original customer any defective component. This is the sole and exclusive remedy.

This warranty is contingent upon proper use of the System and does not cover Systems that have been modified (including the addition of parts) without the approval of SCI PRODUCTS INC. or which are in need of repair due to damage from external cause, including accident, collision, improper handling, improper transporting, failure to properly maintain the System as recommended by SCI PRODUCTS INC., abuse, misuse or which have been damaged by outside parties not employed by SCI PRODUCTS INC., whether in installation or otherwise.

THIS IS A LIMITED WARRANTY AND IT IS THE ONLY WARRANTY MADE BY SCI Products INC. SCI PRODUCTS INC. MAKES, AND CUSTOMER RECEIVES, NO OTHER WARRANTY, EXPRESS OR IMPLIED, INCLUDING BUT NOT LIMITED TO THE IMPLIED WARRANTIES OR MERCHANTABILITY AND FITNESS FOR A PARTICULAR PURPOSE. SCI PRODUCTS INC. SHALL HAVE NO LIABILITY WITH RESPECT TO ITS OBLIGATIONS UNDER THIS WARRANTY FOR CONSEQUENTIAL, EXEMPLARY OR INCIDENTAL DAMAGES EVEN IF IT HAS BEEN ADVISED OF THE POSSIBILITY OF SUCH DAMAGES. THERE ARE NO WARRANTIES WHICH EXTEND BEYOND THIS DOCUMENT WITH RESPECT TO THE PRODUCT INDICATED ABOVE. BUYER ACKNOWLEDGES THAT ANY STATEMENTS MADE WHICH ARE NOT FOUND IN THIS DOCUMENT ARE NOT PROMISES TO BE RELIED UPON.

THE BUYER AGREES TO INSPECT THE PRODUCT ON RECEIPT AS FULLY AS THE BUYER DESIRES AND TO NOTIFY SCI PRODUCTS INC. OF ANY REVEALED DEFECT.

Corporate Office:
2500 Production Drive • St. Charles, Il 60174
Telephone: 630-377-9100
workareaprotection.com

ATT2015