

Note:

A version of this report was originally published in the docket for this investigation on October 4, 2023. The attached report replaces that version and has updated safety recommendation numbers and an updated Board Member title.



AVIATION



HIGHWAY



MARINE



RAILROAD



PIPELINE

September 27, 2023

Hazardous Materials Investigation Report HZIR-23-01

BNSF Railway Company Derailment and Pool Fire Involving DOT-117J Tank Cars

Oklaunion, Texas
January 8, 2022

Abstract: This report discusses the January 8, 2022, derailment of BNSF Railway Company train U-JOENYF7-07A on the BNSF Railway Company Red River Division in Oklaunion, Texas. The train was transporting denatured ethanol, a flammable liquid. It derailed 37 US Department of Transportation specification 117J tank cars, 28 of which became involved in a pool fire. No injuries or fatalities were reported. Safety issues identified in this report include lack of thermal performance standards for gaskets used in tank cars in flammable liquid service, inappropriate application of pressure tank car thermal protection standards to non-pressure tank cars, and lack of rejection criteria for oversized welds during tank car fabrication. Two recommendations are made to the Federal Railroad Administration, three recommendations are made to the Pipeline and Hazardous Materials Safety Administration, and two recommendations are made to the Association of American Railroads.

Contents

| | |
|---|------------|
| Figures | iii |
| Tables | iv |
| Acronyms and Abbreviations..... | v |
| Executive Summary..... | vi |
| What Happened..... | vi |
| What We Found | vi |
| What We Recommended | vii |
| 1 Factual Information | 1 |
| 1.1 The Accident..... | 1 |
| 1.2 Hazardous Materials Transportation..... | 3 |
| 1.2.1 BNSF Railway..... | 3 |
| 1.2.2 Trinity Industries..... | 3 |
| 1.3 Regulatory Requirements and Industry Standards | 4 |
| 1.3.1 Thermal Protection | 4 |
| 1.3.2 Tank Car Attachment Welds..... | 6 |
| 1.3.3 Certificate of Construction..... | 7 |
| 1.3.4 Accident Tank Car Certification | 8 |
| 1.4 Postaccident Tank Car Examination and Testing..... | 8 |
| 1.4.1 DOT-117J Tank Car Damage and Release Assessment..... | 8 |
| 1.4.2 Tank Car Service Equipment and Gaskets..... | 10 |
| 1.4.3 Tank Car Welds | 12 |
| 1.5 Federal Railroad Administration Inspection of Trinity Industries..... | 16 |
| 2 Analysis | 18 |
| 2.1 Introduction | 18 |
| 2.2 Thermal Damage | 18 |
| 2.2.1 Gasket Service Temperatures | 18 |
| 2.2.2 Thermal Protection Requirements for DOT-117 Tank Cars | 22 |
| 2.3 Underframe Attachment Welds and the 85 Percent Rule..... | 24 |

3 Conclusions 29
Findings 29

4 Recommendations 31
New Recommendations..... 31

Appendixes 33
Appendix A: Investigation 33
Appendix B: Consolidated Recommendation Information 34

References..... 37

Figures

| | |
|---|----|
| Figure 1. Aerial view of accident scene. (Photo courtesy of BNSF.)..... | 2 |
| Figure 2. Illustration of several tank car underframe components from a 3D computer model. (Courtesy of Trinity Industries with NTSB annotations.) | 6 |
| Figure 3. The A-end head of tank car TILX731751 postderailment and with the head shield removed for inspection, showing deformation from three impacts..... | 9 |
| Figure 4. Manway cover gasket removed from tank car TILX731758. | 11 |
| Figure 5. Open manway cover showing burnt gasket material on tank car TILX731739. | 11 |
| Figure 6. Fillet weld cross-section diagram with theoretical measurements on the left and the effective throat on the right. | 13 |
| Figure 7. Head-on view of sectioned piece from tank car TILX731751. | 14 |
| Figure 8. Close-up view of sectioned piece from tank car TILX731751..... | 15 |
| Figure 9. Diagram of fracture locations. | 25 |

Tables

Table 1. Release volumes by damage type and tank car count. 10

Table 2. Comparison between measured throat sizes and design throat sizes on tank car TILX731751. 16

Acronyms and Abbreviations

| | |
|------------|--|
| AAR | Association of American Railroads |
| AWS | American Welding Society |
| BNSF | BNSF Railway Company |
| <i>CFR</i> | <i>Code of Federal Regulations</i> |
| DOT | Department of Transportation |
| FRA | Federal Railroad Administration |
| MSRP | Manual of Standards and Recommended Practices |
| NTSB | National Transportation Safety Board |
| PRD | pressure relief device |
| PHMSA | Pipeline and Hazardous Materials Safety Administration |
| RSPA | Research and Special Programs Administration |
| TCC | Tank Car Committee |

Executive Summary

What Happened

On January 8, 2022, about 9:49 a.m. local time, an eastbound BNSF Railway Company train, U-JOENYF7-07A, derailed 37 tank cars at milepost 156.2 on the BNSF Railway Company Red River Division in Oklaunion, Texas. The train had 2 crewmembers on board and was composed of 2 head-end locomotives, 1 distributed power locomotive at the rear of the train, 2 buffer railcars, and 96 loaded US Department of Transportation specification 117J (DOT-117J) tank cars carrying denatured ethanol, a flammable liquid. The BNSF Railway Company estimated that 601,819 gallons of denatured ethanol released from 28 of the 37 derailed tank cars. The ethanol ignited and burned uncontrolled for about 4 hours, resulting in a pool fire. No injuries or evacuations were reported.

What We Found

The majority of the ethanol released leaked from tank car service equipment (such as manway covers and bottom outlet valves) that remained intact during the derailment but sustained damage from the pool fire. We found that the gaskets used in the service equipment were made of materials that are vulnerable to damage when exposed to fire. Using gaskets made of more thermally resistant materials would likely increase the survival time of tank cars exposed to fire and reduce the severity of hazardous material releases.

We also found that when the Pipeline and Hazardous Materials Administration created the DOT-117 specification (which includes the DOT-117J specification) for non-pressure tank cars, it expanded existing thermal protection regulations for pressure tank cars to non-pressure tank cars with different designs.

Further, we found that a mechanical (non-thermal) breach of a tank car involved in the derailment occurred because of loading between underframe components and tank head material—an outcome that a specific federal regulation and an industry standard, the 85 percent rules, are intended to prevent. This load scenario likely occurred because several of the tank car's welds exceeded the sizes specified in the design, which led to the tank head material being the weakest point in the load path and fracturing, releasing lading. Further, because there is not an industry standard for rejecting an oversized weld, the design size for each weld is effectively a minimum size, and that as-built tank cars may have oversized welds that may lead to tank fractures. Relatedly, we found that a design that complies with the

85 percent rules does not prevent fabrication of tank cars that may violate the rules because of oversized welds that make the tank cars more vulnerable to tank fractures in a derailment.

What We Recommended

As a result of this investigation, we recommended that the Federal Railroad Administration and the Pipeline and Hazardous Materials Administration work together to develop and publish both benchmarks and thermal performance standards for gaskets used in tank cars transporting flammable liquids. We also recommended that the Pipeline and Hazardous Materials Administration revise the DOT-117 tank car specification to ensure that these tank cars use appropriate thermal protection systems, and that the Association of American Railroads update its certification process to ensure that tank cars comply with this revised specification.

We also recommended that the Association of American Railroads create an inspection standard in the Manual of Standards and Recommended Practices for rejecting oversized welds at key points on tank car underframes.

1 Factual Information

1.1 The Accident

On January 8, 2022, about 9:49 a.m. local time, an eastbound BNSF Railway Company (BNSF) train U-JOENYF7-07A, derailed 37 tank cars at milepost 156.2 on the BNSF Red River Division in Oklaunion, Texas.¹ (See figure 1.) Train U-JOENYF7-07A was a high-hazard flammable train (HHFT) carrying denatured ethanol.² The train had 2 crewmembers on board (1 conductor and 1 engineer) and was composed of 2 head-end locomotives, 1 distributed power locomotive at the rear of the train, 2 buffer railcars, and 96 loaded US Department of Transportation (DOT) specification 117J (DOT-117J) tank cars. BNSF estimated that 601,819 gallons of denatured ethanol released from 28 of the 37 derailed tank cars.³ The ethanol ignited and burned uncontrolled for about 4 hours, resulting in a pool fire. No injuries or evacuations were reported. Equipment damages were estimated at \$5 million. Visibility conditions at the time of the derailment were overcast and the temperature was 59°F, with wind from the south at 15 mph.

¹ Visit [ntsb.gov](https://www.ntsb.gov) to find additional information in the [public docket](#) for this National Transportation Safety Board (NTSB) investigation (case number [HMD22LR001](#)). Use the [CAROL Query](#) to search safety recommendations and investigations.

² *Denatured ethanol* is ethanol treated with gasoline to render it undrinkable. The ethanol in this derailment was being shipped as UN1987 Alcohols, N.O.S. (Ethanol, Natural Gasoline), Class 3, Packing Group II. Hazardous material classifications are based on types and overall levels of hazard (such as flammability, radioactivity, and corrosiveness). Packing groups for Class 3 flammable liquids are determined by boiling points and flashpoints. Lower packing group numbers indicate greater hazards. See Title 49 *Code of Federal Regulations (CFR)* Part 173, Subpart D and 49 *CFR* 172.101. A Class 3 flammable liquid in Packing Group II presents a medium hazard.

³ The NTSB investigated this hazardous materials release under the authority for 49 US Code 1116(b)(5), which states that the NTSB shall "evaluate the adequacy of safeguards and procedures for the transportation of hazardous material and the performance of other departments, agencies, and instrumentalities of the government responsible for the safe transportation of that material." Our investigation was focused only on the performance of the DOT-117J tank cars in this derailment. Accordingly, we did not determine the probable cause of the derailment.



Figure 1. Aerial view of accident scene. (Photo courtesy of BNSF.)

Event recorder data from the lead locomotive indicated train U-JOENYF7-07A was traveling at the maximum authorized track speed of 50 mph at the time of the derailment.⁴ Each loaded tank car was carrying about 28,900 gallons of denatured ethanol. Denatured ethanol was the only hazardous material released.

BNSF response teams found five tank cars were burning as part of the pool fire when they first arrived at the scene. Over the next 4 hours, the fire spread to involve 28 of the 37 derailed tank cars. Ten of the derailed tank cars released ethanol primarily because of mechanical damage to their tanks and fittings, while the remaining 18 breached tank cars primarily released product when their service equipment became thermally damaged in the pool fire.⁵

The BNSF's response teams' and responding fire departments' highest priority was containing the fire, and they did not record a detailed timeline of the fire's extent

⁴ Under 49 *CFR* 174.310(a)(2), HHFTs are limited to a maximum speed of 50 mph.

⁵ (a) This report addresses the main (or primary) types of damage that led to each tank car breaching. For additional detail, refer to the Hazardous Material Factual Report in the docket in this investigation. (b) *Service equipment* includes manways, outlet valves, pressure relief devices (PRDs), and other tank features that penetrate the tank's shell and can create a leak path with no damage to the shell itself. *PRDs* are spring-loaded valves designed to vent lading if the pressure in the tank rises above a design threshold.

and severity. The BNSF response teams did measure temperatures at several locations within and near the derailment pileup. At the west end of the derailment near tank cars that were still upright and on the track, temperatures reached 90–200°F. At the first burning but upright tank car at the west end of the derailment, temperatures reached 700–800°F. At a tank car near the middle of the derailment pileup, temperatures reached 800–1040°F. At the east end of the derailment, where tank cars were overturned but not on fire, the temperature matched the ambient temperature.

1.2 Hazardous Materials Transportation

1.2.1 BNSF Railway

BNSF is a Class I railroad with a rail network of 32,500 route miles in 28 states and 3 Canadian provinces. BNSF completed a safety and security inspection of the tank cars on train U-JOENYF7-07A on January 8, 2022, before accepting them for service from the shipper. BNSF found no exceptions with the condition of the tank cars.

1.2.2 Trinity Industries

Trinity Industries, Inc., produces and supplies railcars and railcar parts.⁶ Trinity Industries also offers services such as railcar fleet management, railcar leasing and management services, and repair services.

The tank cars comprising train U-JOENYF7-07A were DOT-117J tank cars built by Trinity Industries, which leased them to the shipper. Most of these tank cars were part of Trinity Industries' TILX series. DOT-117J tank cars are a subset of the DOT-117 specification described in Title 49 *Code of Federal Regulations (CFR)* Part 179 Subpart D and are new-built to meet the specification.⁷ DOT-117 tank cars are intended to offer improved accident survivability without release of lading over the older DOT-111 specification.

⁶ Trinity Industries' subsidiary, Trinity Tank Car, Inc., builds tank cars, while another subsidiary, Trinity Industries Leasing Company, Inc., provides railcar leasing services.

⁷ DOT-117R-type tank cars are retrofitted to meet the specification, and DOT-117P-type tank cars must meet performance standards instead of some of the design standards specified for J or R tank cars.

The accident tank cars were designed to meet the DOT-117J specification and were certified by the Association of American Railroads (AAR) Tank Car Committee (TCC) on January 23, 2020. The design included head shields intended to improve tank head puncture resistance, a ceramic fiber thermal protection blanket and pressure relief devices (PRDs) intended to improve survivability during torch and pool fires, a robust protective housing around the top fittings for rollover protection, handles for bottom outlet valves designed to prevent actuation during accidents, and thicker tank shell material constructed of normalized steel intended to improve tank survivability.⁸

The DOT-117J design and manufacturing specifications prescribed rubber (nitrile) gaskets for manways and Tealon™ (TF1570E, a specific type of reinforced polytetrafluoroethylene) gaskets for all other service equipment except the inner workings of the PRDs. The rubber gaskets used on the manways have a maximum service temperature of 250°F. The maximum service temperature for Tealon™ is 500°F. The PRDs on the tank cars involved in the Oklaunion derailment were a standard part manufactured by two other companies: Kelso Technologies and Fort Vale Engineering. The PRDs used Viton® O-rings with an intermittent high-temperature performance of 601°F.⁹

1.3 Regulatory Requirements and Industry Standards

Below is a summary of regulatory requirements and industry standards related to the tank cars involved in the accident.

1.3.1 Thermal Protection

Thermal protection systems limit heat transfer into the tank during exposure to pool and torch fires and minimize the potential for heat and pressure-induced hazardous materials releases and catastrophic tank failure. Under 49 *CFR* 179.202-6, DOT-117 tank cars must have a thermal protection system that conforms to 49 *CFR*

⁸ (a) Top fittings are part of a tank car's service equipment and include features like liquid and vapor valves and PRDs. (b) Normalized steel has been thermally processed to make it stronger and tougher.

⁹ Viton® is a registered trademark of the Chemours Company for a range of rubber copolymer products that are heat- and chemical-resistant because they use vinylidene fluoride and other fluoropolymers. These rubbers are known as fluoroelastomers, and several manufacturers produce rubber products that meet the same standards as Viton®.

179.18, including a 0.5-inch or thicker thermal protection blanket and a reclosing PRD.¹⁰ Title 49 *CFR* 179.18 sets a performance standard for thermal protection systems. Tank cars must not release any lading except through a PRD for 100 minutes when subjected to a pool fire, or for 30 minutes when subjected to a torch fire.¹¹ The regulation requires analysis to verify compliance with this performance standard. Analysis must consider “fire effects on and heat flux through tank discontinuities, protective housings, underframes, metal jackets, insulation, and thermal protection” (49 *CFR* 179.18(b)).¹²

Title 49 *CFR* 179.18(c) requires DOT-117 tank cars to use a thermal protection system from the list of approved systems maintained by the US DOT.¹³ A system on this list does not require re-testing to verify that it meets the performance standard. Each system on the list includes a thermal protection blanket, coating, or wrap that incorporates material tested according to procedures described in Appendix B of 49 *CFR* 179. The Appendix B procedures require testing a sample of thermal protection blanket material applied to a bare plate with thermal properties equivalent to tank shell material. Title 49 *CFR* 173.31(b)(2) requires tank cars built after 1991 transporting Class 3 material (which includes ethanol) to have a reclosing PRD.

The AAR Manual of Standards and Recommended Practices (MSRP) contains a performance standard similar to that of 49 *CFR* 179.18: each combination of tank car, PRD, thermal protection system, and lading material must be capable of withstanding a full-immersion pool fire for 100 minutes or a torch fire for 30 minutes under specified conditions (AAR 2014a). Verification of performance must consider the heat flux through tank car service equipment, protective housings, underframes, metal jackets, insulation, and the thermal protection system.

¹⁰ The thermal protection blanket must comply with 49 *CFR* 179.18(c) and the reclosing PRD must comply with 49 *CFR* 173.31.

¹¹ See 49 *CFR* 179 Appendix B for a description of simulated pool and torch fire conditions, which are otherwise undefined by regulation.

¹² *Tank discontinuities* is synonymous with *service equipment* as used in this report.

¹³ This list uses “thermal protection system” in a narrower sense than 49 *CFR* 179.202-6; the listed systems include coatings, blankets, or insulating wraps designed to limit heat transfer into the tank; they do not specify or include PRDs. DOT-117 tank cars must still use PRDs that comply with 49 *CFR* 173.31.

1.3.2 Tank Car Attachment Welds

Tank cars include structural elements that support and protect the tank. One of these elements, the stub sill, is the part of the underframe below the tank itself and above the trucks (which house the tank cars' wheelsets). Stub sills are attached to tanks using sill pads to reduce stress on the tank shell during normal operations.¹⁴ At each end of a tank car, where the head of the tank curves away from the stub sill, a head brace fills in the space between the curved section of the sill pad—often called a front sill pad to distinguish it from sill pads that may be installed nearer the center of the tank. (See figure 2.)

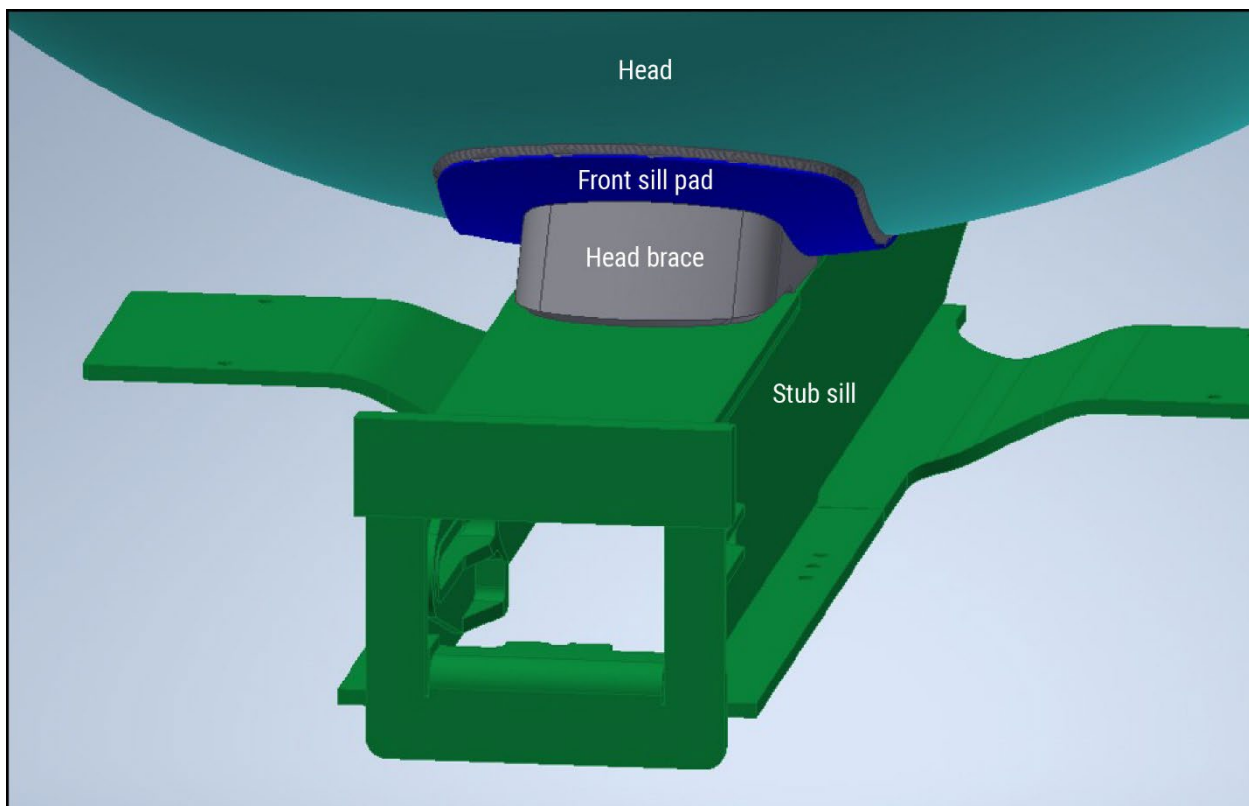

Figure 2. Illustration of several tank car underframe components from a 3D computer model. (Courtesy of Trinity Industries with NTSB annotations.)

Federal regulations at 49 *CFR* 179.200-19 require that welds attaching a structural element of a tank car to a pad have an ultimate shear strength that does not exceed 85 percent of the ultimate shear strength of the welds attaching the pad to

¹⁴ *Stress* is the reaction of a material to a force and is measured as force per unit area.

the tank.¹⁵ This is known as the 85 percent rule. The welds that join the stub sill or head brace and the pads are intended to serve as a point of failure in the load path between the stub sill and tank. In other words, the force required to break the weld between the structural element and the reinforcing pads should be less than the force required to break the weld between the reinforcing pads and the tank. If the stub sill is overloaded, the head brace or stub sill tears away from the pads rather than the pads tearing away from the tank itself; this makes the tank head or shell material less likely to fracture.

AAR MSRP design standards state that the welds securing the stub sill to the pads shall have a total throat area not exceeding 85 percent of the total throat area of the pad-to-tank welds (AAR 2015).¹⁶ Throat area, discussed in section 1.4.3, is the product of a weld's length and its throat, a dimensional measurement used to calculate weld strength per inch of length. When welds are made using weld materials with the same ultimate tensile strength, the welds' relative strengths can be determined by comparing their total throat areas. Because throat area correlates with weld strength, the AAR standard is similar to the federal requirement. This report refers to the AAR standard and regulatory requirement collectively as the 85 percent rules.

1.3.3 Certificate of Construction

Before a tank car is placed in service, it must have a Certificate of Construction issued by the AAR certifying that the tank, equipment, and car fully conform to the specification set by regulation. Under 49 *CFR* 179.3, a tank car manufacturer submits specifications with detailed drawings to the AAR Executive Director–Tank Car Safety for consideration by the AAR TCC and other appropriate committees. The TCC is instructed to approve designs that, in the TCC's opinion, meet all federal requirements.

Under 49 *CFR* 179.5, a tank car manufacturer must furnish a Certification of Construction (Form AAR 4-2) to the tank car owner and to the AAR Executive

¹⁵ *Ultimate shear strength* is the maximum resistance of a material against a stress which acts parallel to a plane on which a force has been applied.

¹⁶ (a) As used in designs, *throat area* is the product of a weld's length and theoretical throat. (b) According to the standard, these throat areas may be modified to use equivalent area values if the welding procedure differs for each weld area under consideration and may also be modified for parent metal strength considerations.

Director–Tank Car Safety. The Certificate of Construction certifies that the tank, equipment, and car conform to the requirements of the tank car’s specification. A single certificate is sufficient for a series of tank cars if the tank cars are identical.

1.3.4 Accident Tank Car Certification

Trinity Industries applied for a single Certificate of Construction for a series of tank cars that included many of the accident tank cars on December 18, 2019. The application included detailed drawings and AAR Form 4-2. The detailed drawings included diagrams of the tank cars’ underframe attachments, including stub sills, sill pads, and head braces. The drawings listed weld areas and (based on those areas) calculated shear strengths for the welds joining the tank to the sill pad and the sill pad to other structural elements. The drawings also specified a 0.5-inch-thick thermal protection blanket, which covered the tank car head and shell but not the service equipment.

The submitted AAR Form 4-2 also included data about the thermal conductivity of the thermal protection blanket—that is, how resistant the material was to heat transfer. Trinity Industries obtained these data from the thermal blanket manufacturer, who hired an independent laboratory to test the ceramic fiber material used in the tank cars’ thermal protection blankets. The test procedures met the requirements in Appendix B of 49 *CFR* Part 179. Trinity Industries did not complete a thermal analysis that modeled thermal effects over the entire surface of the tank car or account for thermal effects on service equipment; the omission of this thermal analysis is permitted when a tank car manufacturer uses a thermal protection system from the US DOT pre-approved list, and the system used by Trinity Industries was on the list. The submitted drawings showed that the thermal protection system did not include provisions for protecting the tank car’s manway cover, bottom outlet valve, or other service equipment. The submitted form also specified PRDs designed to release material when the pressure inside the tank car reached 75 pounds per square inch. The AAR TCC approved the application for a Certificate of Construction on January 23, 2020.

1.4 Postaccident Tank Car Examination and Testing

1.4.1 DOT-117J Tank Car Damage and Release Assessment

The NTSB conducted on-scene examinations of the accident tank cars on January 27–28, 2022, and recovered tank car components for laboratory examination, including a section of underframe assembly, shell plate material, and gasket materials.

Using knowledge gained from on-scene examinations, bills of lading, and the amount of ethanol BNSF recovered after the pool fire was extinguished, the NTSB developed estimates for total release volumes from various kinds of damage. The NTSB determined that seven derailed tank cars sustained mechanical breaches to tank heads or shells. Together, these seven breaches released about 179,885 gallons of ethanol. Mechanical damage to tank car service equipment on three additional tank cars released about 68,459 gallons of ethanol.

Visual examination of TILX731751, one of the seven tank cars with head or shell breaches, revealed the tank head material fractured near a weld joining the tank to the underframe assembly. (See figure 3.) This tank car was mechanically breached even though it was near the rear of the derailment pileup, where collision forces would have been lowest. The NTSB acquired a section of tank shell, head, and underframe assembly from this tank car for laboratory examination.



Figure 3. The A-end head of tank car TILX731751 postderailment and with the head shield removed for inspection, showing deformation from three impacts.

The NTSB identified 18 derailed tank cars that were not mechanically breached but sustained thermal breaches: damage from heat exposure severe enough to cause loss of lading. Thermal breaches can include thermal tears (failure of a tank head or shell) or damage to tank service equipment.¹⁷ In the Oklaunion derailment, no tank heads or shells had thermal tears; all 18 thermally breached tank cars lost lading through service equipment. These breached tank cars released about 353,475 gallons of ethanol. (See table 1.)

Table 1. Release volumes by damage type and tank car count.

| Primary Source of Release | Number of Tank Cars | Gallons Released |
|--|---------------------|------------------|
| Mechanical damage to tank head and shell | 7 | 179,885 |
| Mechanical damage to service equipment | 3 | 68,459 |
| Thermal damage to service equipment, PRD function | 18 | 353,475 |
| Total | 28 | 601,819 |

1.4.2 Tank Car Service Equipment and Gaskets

Gaskets sustained different degrees of damage at different locations relative to the pool fire. The manway cover gasket on a tank car near the edge of the pool fire (TILX731758) was cracked, missing material, and textured like alligator skin. (See figure 4 for an image of this gasket taken after the NTSB removed it from the scene.) The manway cover gasket on a tank car near the center of the pool fire (TILX731758) had burned to small fragments and carbon deposits, which were retained by the manway cover gasket groove. (See figure 5.)¹⁸ The NTSB examined service equipment removed from four derailed tank cars that were near the edge of the pool fire and had sustained less thermal damage than tank cars nearer the center. These examinations prompted laboratory tests of gasket material thermal performance.

¹⁷ Tank service equipment includes PRDs. Tank cars exposed to heat can release material through normal PRD function; this is not considered a thermal breach but does result in lost lading. A thermally damaged PRD that releases material when it should close or remain closed is considered a thermal breach.

¹⁸ The equipment was removed and tested by Trinity Industries and the FRA at the TrinityRail facility in Saginaw, Texas. More information about the tank cars chosen for equipment recovery and testing is available in the docket for this report.



Figure 4. Manway cover gasket removed from tank car TILX731758.



Figure 5. Open manway cover showing burnt gasket material on tank car TILX731739.

Laboratory tests of PRDs from these tank cars found that the internal gaskets had sustained thermal damage such that the PRDs could not retain lading significantly below the pressures at which the PRDs were designed to re-close.

Similarly, postaccident testing of other service equipment found that the gaskets were thermally damaged and unable to retain lading.

The NTSB directed thermal exposure testing on a rubber manway cover gasket removed from a tank car not involved in the pool fire. The gasket was made of butadiene acrylonitrile rubber, a type of nitrile rubber. These tests exposed gasket sections to four temperatures for 15-minute periods: 250°C (482°F), 300°C (572°F), 350°C (662°F), and 400°C (752°F). Each temperature produced a different, visually distinct level of damage. At the highest test temperature, the gasket material ignited and was mostly consumed; thus, higher temperatures would not have produced usefully different examples of damage.

1.4.3 Tank Car Welds

In general, weld strength is a function of weld shape and size. The welds that secure tank car structural elements to pads and pads to tanks include fillet welds, which join two pieces of metal, often at a right angle as in a T-joint. Design specifications use measurements between weld features to define fillet weld size. The point where the welded external surfaces intersect is the joint root. The distance the fillet weld extends along each surface from the joint root is a leg. The end of the leg farthest from the joint root is the toe. The theoretical throat is the shortest distance from the joint root to a line drawn between the toes of the weld.¹⁹ Effective measurements (such as effective throat) are performed from the weld root, which is the deepest point where the weld metal (or weld filler) intersects the joint surfaces; effective throat allows for a more accurate calculation of weld strength than does theoretical throat. (See figure 6.) Because a weld root is inaccessible without cutting a cross section of a weld, design specifications and inspection standards consistently use theoretical measurements.

¹⁹ The *theoretical throat* does not extend all the way to the true surface of the weld if the weld is convex—that measurement is the *actual throat*, and it is not usually used in designs or when evaluating weld strengths, because additional material producing a convex bulge does not tend to contribute to weld strength.

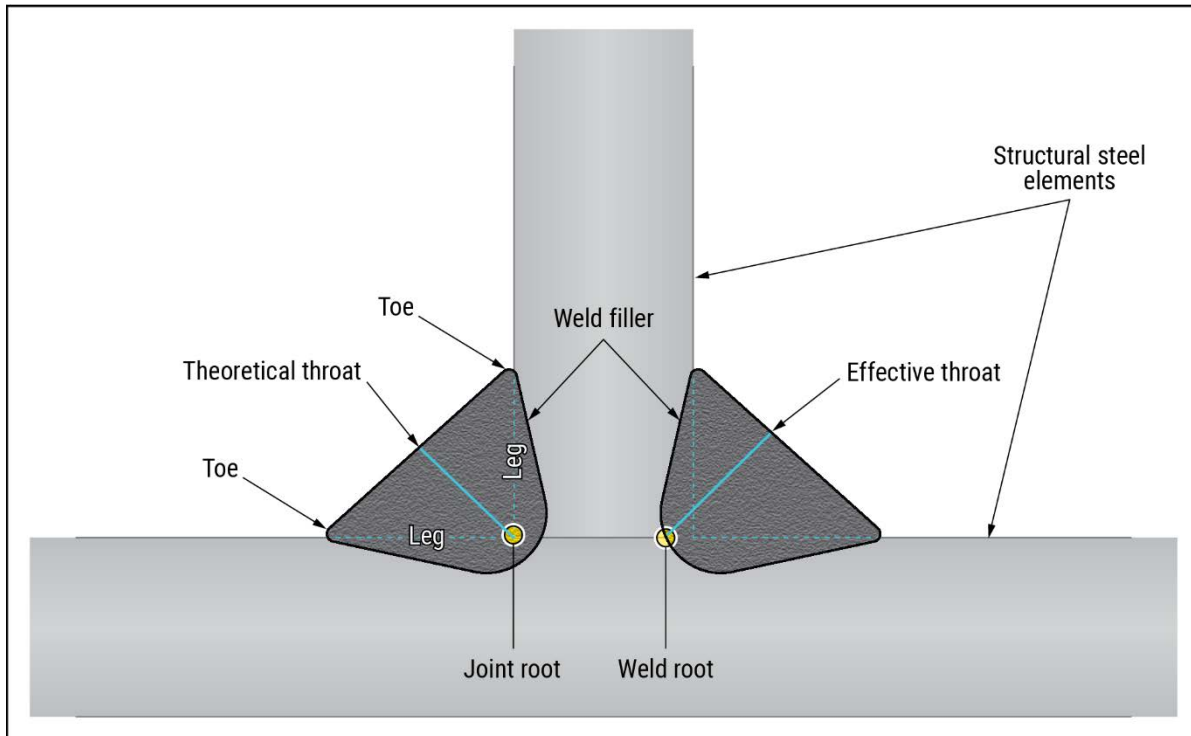

Figure 6. Fillet weld cross-section diagram with theoretical measurements on the left and the effective throat on the right.

The NTSB sectioned a piece of tank shell, head, front sill pad, head brace, and stub sill from the tank car that was mechanically breached when its head material fractured near a weld. (See figure 7 for a head-on view of the examined piece.) Examination found that the 0.625-inch-thick front sill pad was fractured at the toe of the weld that joined it to the head brace; it had not separated along the weld itself. The tank head wall was fractured at the weld root between the front sill pad window and the tank head (the window weld).²⁰ The head fracture was about 10.25 inches long, and the maximum opening displacement was about 2.5 inches. (See figure 8 for a close-up of the fracture and resulting opening.) The head brace remained attached to the stub sill.

²⁰ The *window* is a central rectangular opening in the front sill pad with edges that are welded to the tank head.



Figure 7. Head-on view of sectioned piece from tank car TILX731751.

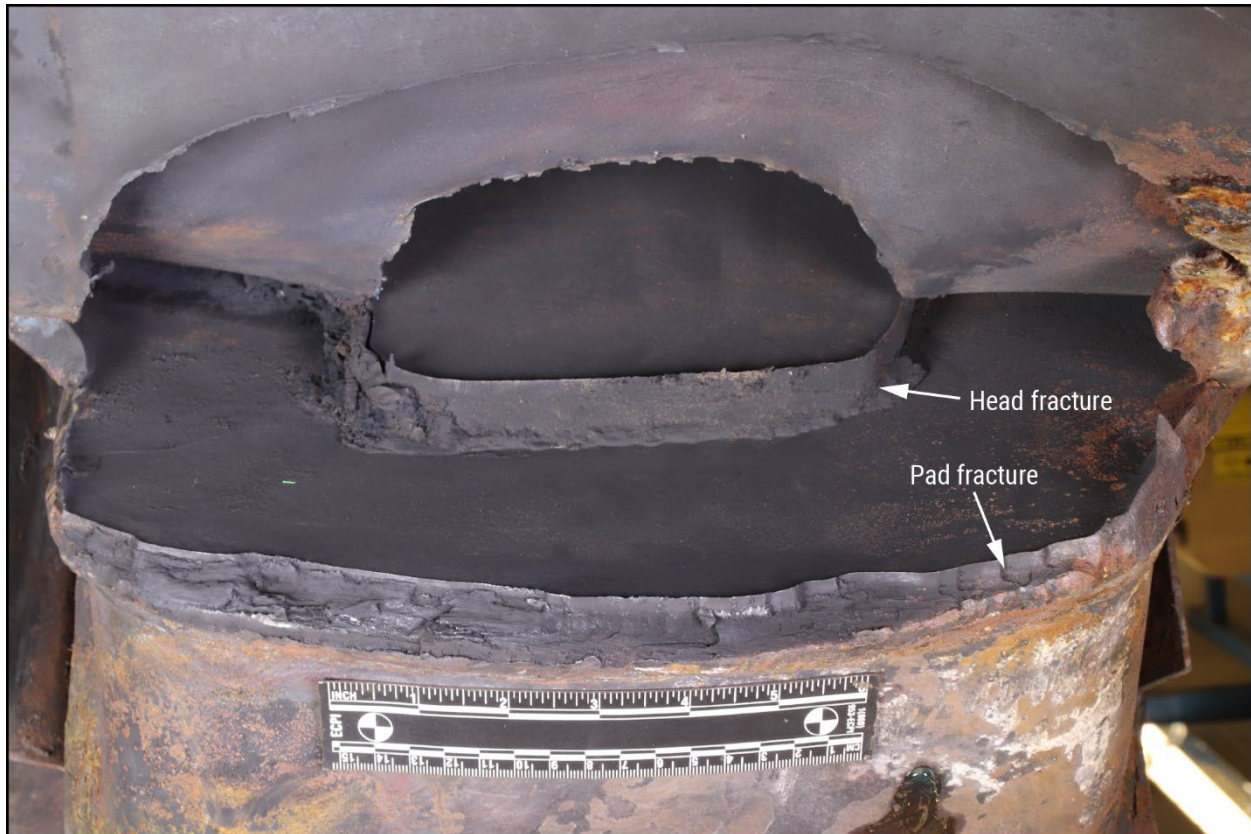

Figure 8. Close-up view of sectioned piece from tank car TILX731751.

The fracture and deformation patterns were consistent with bending loads at the fracture locations, including through the front sill pad at the head brace weld toe and through the tank at the window weld in the front sill pad. The head and outboard portion of the front sill pad deformed upward and inboard relative to the stub sill and head brace. Like the visual evidence of larger deformations in the tank head, this deformation is consistent with the tank car sustaining impacts with other tank cars (See figure 3 above.)

The NTSB examined several cross-sections of the piece discussed above, including one through the tank car's centerline as discussed below. Based on this examination and the drawings Trinity Industries submitted to the AAR as part of its application for a Certificate of Construction, the NTSB determined that near the tank car centerline, the effective throat sizes of the welds joining the front sill pad to the tank head were 32% larger than the design size (the theoretical throat) at the outboard edge and 71% larger than the design size at the window edge. The welds

joining the head brace to the front sill pad at the outboard and inboard sides were oversized by 29% and 97%, respectively.²¹ (See table 2.)

Table 2. Comparison between measured throat sizes and design throat sizes on tank car TILX731751.

| Weld | Measured Effective Throat (inches) | Specified Theoretical Throat (inches) | Excess Throat Size (%) |
|----------------------------------|------------------------------------|---------------------------------------|------------------------|
| Sill pad to tank, window | 0.453 | 0.265 | 71 |
| Sill pad to tank, outboard | 0.350 | 0.265 | 32 |
| Head brace to sill pad, inboard | 0.348 | 0.177 | 97 |
| Head brace to sill pad, outboard | 0.341 | 0.265 | 29 |

1.5 Federal Railroad Administration Inspection of Trinity Industries

On September 22, 2022, the FRA inspected the Trinity Industries tank car fabrication facility in Longview, Texas, for compliance with its AAR-approved quality assurance program.²² The FRA inspector observed oversize welds for attachments to tanks, including pad-to-tank, head-brace-to-pad, and head-brace-to-stub-sill, such that these welds could not ensure compliance with the 85 percent rules. The inspector further noted that approved tank car drawings had a weld tolerance for undersized welds but not for oversized welds. The inspector also found the Trinity Industries quality assurance standard did not have an upper weld size threshold. The FRA notified Trinity Industries that because the AAR-approved drawings did not have a weld tolerance for oversize welds, the weld sizes must not exceed the weld sizes stipulated on the AAR-approved drawing. The FRA directed Trinity Industries to submit and implement a quality action plan to address this issue. On October 27, 2022, the Trinity Industries manager of quality assurance submitted an action plan to the FRA, which in part stated that “acceptance criteria for welds comes from AAR

²¹ For images of these welds and additional measurements, refer to the Materials Laboratory Factual Report in the docket for this investigation.

²² TrinityRail, Longview Texas, Inspection Report, September 22, 2022, Form FRA F6180.96. The AAR-approved tank car quality assurance program is required by 49 *CFR* 179.7. The program ensures the finished product conforms to the requirements of the applicable specifications and regulations.

MSRP C-III Appendix W and AWS [American Welding Society] D15.1 depending on the weld classification.”

AWS D15.1 specifies a fillet weld maximum size for welder qualification (AWS 2019). However, a maximum weld size is not listed in the visual inspection acceptance criteria. Similarly, Appendix W of the MSRP does not include a limit for deviations above the specified weld size (AAR 2014b). In other words, neither standard provides criteria for rejecting oversized welds during visual inspection.

2 Analysis

2.1 Introduction

On January 8, 2022, BNSF train U-JOENYF7-07A, a HHFT (high hazard flammable train), derailed 37 tank cars in Oklaunion, Texas. Twenty-eight of the 37 derailed tank cars released about 601,819 gallons of denatured ethanol. The ethanol ignited and burned uncontrolled for about 3 hours, resulting in a spreading pool fire. No injuries or evacuations were reported.

While 10 tank cars sustained mechanical breaches, the majority of the ethanol released was released through thermal breaches. This analysis discusses the following safety issues:

- Lack of thermal performance standards for gaskets used in tank cars in flammable liquid service (section 2.2.1)
- Inappropriate application of pressure tank car thermal protection standards to non-pressure tank cars (section 2.2.2)
- Lack of rejection criteria for oversized welds during tank car fabrication (section 2.3)

2.2 Thermal Damage

2.2.1 Gasket Service Temperatures

When first responders arrived at the scene of the derailment, 5 of the 37 derailed tank cars were burning as part of a pool fire. Four hours later, the pool fire had spread to involve 28 of the 37 derailed tank cars.

The design and manufacturing specifications for the tank cars in the Oklaunion derailment prescribed nitrile rubber gaskets for manways and Tealon™ gaskets for all other service equipment except PRDs. The nitrile rubber gaskets used on the manways had a maximum service temperature of 250°F and the maximum service temperature for Tealon™ is 500°F. However, the temperature of the pool fire as measured by the BNSF response team ranged from about 700-800°F at the western edge to about 800-1040°F near the center of the fire. Both these ranges exceeded the maximum service temperature of both types of gaskets.

The NTSB's on-scene examination of the DOT-117J tank cars and postaccident testing of the equipment recovered from the accident showed that 18 of the 25 cars involved in the pool fire were not mechanically breached but still released lading. The NTSB examined tank car service equipment (manways, valves, and other tank features that penetrate the tank's shell) recovered from derailed tank cars. The service equipment was not enclosed within the tank cars' thermal protection systems, and the manway cover was positioned outside the protective housing that enclosed the top fittings. (See sections 1.2.2 and 1.3.4 for more information about the tank cars' design.) The gaskets installed in the service equipment showed signs of thermal damage; recovered gaskets were cracked, were missing material, or had a texture similar to that of alligator skin. The damage rendered these gaskets unable to retain lading. Gaskets exposed to the highest pool fire temperatures were destroyed; a manway cover gasket on a tank car near the center of the pool fire (the hottest area as measured by responders) had been reduced to small fragments and carbon deposits.

To better understand the thermal performance of gasket material during the pool fire, the NTSB directed laboratory tests to expose gasket material (specifically, samples from a nitrile rubber manway cover gasket removed from a tank car not involved in the pool fire) to temperatures ranging from 350 to 400°C (482–752°F) for 15-minutes. The test produced varying levels of visually distinct damage to the gasket, with the highest test temperature igniting the gasket, which was mostly consumed by the resulting fire.

The NTSB recently investigated a derailment and pool fire similar to the Oklaunion, Texas, accident: the March 30, 2023, derailment of 23 railcars in BNSF mixed freight train L-TWI8801-29I in Raymond, Minnesota, which included 10 DOT-117J tank cars transporting flammable liquid ethanol.²³ Two of the derailed tank cars sustained mechanical breaches to their shells and released ethanol, starting a pool fire. This pool fire thermally damaged manway gaskets of three mechanically intact tank cars, which led to the further release of hazardous materials and spread the fire. The manway gaskets used were made of butadiene acrylonitrile rubber, a type of nitrile rubber similar to that used in the tank cars involved in the Oklaunion accident. According to the manufacturer data, the gaskets in the Raymond accident tank cars had an upper temperature performance limit of 225°F—a temperature lower than the gaskets used on the Oklaunion accident tank cars. The NTSB concludes that

²³ Visit [nts.gov](https://www.nts.gov) to find additional information in the [public docket](#) for this NTSB investigation (case number [RRD23LR009](#)).

gaskets currently used in DOT-117J tank car service equipment may be made of materials vulnerable to thermal damage when exposed to fire, which can lead to the release of hazardous material.

The NTSB has investigated other accidents that involved the thermal performance of gaskets. Following a September 8, 1987, incident at a CSX Transportation interchange yard in New Orleans, Louisiana, in which a tank car leaked flammable butadiene from a manway and burned, resulting in the evacuation of 800-1,000 residents, the NTSB found that federal regulations did not provide criteria or other direction about the manufacture, composition, or thermal performance of gaskets (NTSB 1988). The NTSB issued safety recommendation R-88-58 to the FRA to:

Establish performance standards for determining the acceptability of heat-resistant gaskets required to be used on tank cars.

In a 1995 notice of proposed rulemaking (NPRM), the Research and Special Programs Administration (RSPA, now the Pipeline and Hazardous Materials Safety Administration (PHMSA)) proposed amendments to HM-216, which addresses federal requirements regarding the transportation of hazardous materials by rail. Among the proposed amendments was a performance standard for heat-resistant gaskets based on the heat resistance of asbestos, specifying a gasket capable of surviving temperatures of at least 230°C (446°F).²⁴

On June 5, 1996, RSPA, in cooperation with the FRA, published the final rule amending HM-216.²⁵ RSPA stated that rail industry stakeholders had expressed concern about the difficulty of obtaining suitable heat-resistant materials because of the scarcity of materials other than asbestos that can withstand temperatures of 230°C (446°F) and are also compatible with lading.²⁶ RSPA therefore deferred action on developing criteria for selecting suitable gasket materials because it found the

²⁴ Notice of Proposed Rulemaking HM-216, Transportation of Hazardous Materials by Rail; Miscellaneous Amendments, 60 *FR* 65492, December 19, 1995.

²⁵ (a) Final Rule HM-216, Transportation of Hazardous Materials by Rail; Miscellaneous Amendments. 61 *Federal Register (FR)* 28665, June 5, 1996. (b) RSPA was established in 1992 as a USDOT sub-agency focused on improving hazardous materials and pipeline safety, coordinating, and advancing transportation research, promoting innovative transportation solutions, and managing the USDOT's transportation-related emergency response and recovery responsibilities. RSPA was abolished on November 30, 2004, and some of its duties and responsibilities were transferred to the Pipeline and Hazardous Materials Safety Administration.

²⁶ At the time, asbestos products were being phased out because of health concerns.

matter too technically complex for resolution at that time. Although the new rule did not define a minimum temperature for gasket heat-resistance, it did require that each tank car used for the transportation of anhydrous ammonia, flammable gases, and gases that are poisonous by inhalation have a gasket designed to create a positive seal so that release of the material will not occur under normal transportation conditions. The regulations also required that specific factors, such as the temperature of the lading, compatibility of the gasket with the lading, pressure, and the size of the manway must be considered in the design of the gasket. The NTSB determined that the new regulations met the intent of Safety Recommendation R-88-58, which was classified Closed–Acceptable Action.

Since publication of HM-216 in 1996, suitable non-asbestos heat-resistant gasket materials that can withstand higher temperatures have become more widely available. In the Oklaunion accident, some of the gaskets used on the tank cars were made of Tealon™ (which has a maximum service temperature of 500°F). The NTSB is also aware of spiral-wound gaskets with service temperature limits of 260°C (500°F) but able to survive temperatures exceeding 600°C (1112°F).²⁷ The service temperatures of these gaskets exceed the service temperatures of the nitrile rubber gasket materials used in manway covers of tank cars involved in the Oklaunion and Raymond accidents (250°F and 225°F, respectively). The specified survival temperature of spiral wound gaskets also exceeds the temperature at which the nitrile rubber manway gasket from the Oklaunion derailment ignited.

The use of improved fire-resistant gaskets would significantly increase tank cars' ability to retain hazardous materials during exposure to fires, which could reduce the severity of incidents by preventing damage from spreading to other tank cars, infrastructure, and communities. In both the Oklaunion and Raymond derailments, service equipment gaskets were the tank car component that sustained enough thermal damage to release lading. The NTSB therefore concludes using gaskets with higher service and survival temperatures would likely increase the fire exposure survival time of DOT-117 tank car service equipment in flammable liquid service and reduce the severity of hazardous materials releases.

The NTSB believes the observed gasket failure mode at Oklaunion and Raymond, combined with the current availability of gaskets with higher service and survival temperatures, justifies resuming the deferred discussion of thermal

²⁷ A spiral-wound gasket is a metallic gasket that consists of a carbon steel outer ring, an inner ring to prevent windings from buckling inside the opening, and a sealing element that contains windings and a flexible filler material that can be rated for high temperature.

performance standards begun during the 1996 HM-216 rulemaking, this time with a focus on flammable liquid service. Promulgating thermal performance standards for gaskets used in flammable liquid service would ensure that each tank car is equipped with gaskets that provide better survivability during a fire. This increased survivability would create a more predictable and therefore safer environment for first responders.

In the HM-216 NPRM, RSPA proposed a gasket survival temperature of at least 230°C (446°F). However, as mentioned above, gaskets with higher service and survival temperatures are now available. The first step to developing thermal performance standards for tank cars in flammable liquid service would be to determine what gaskets are available that have higher service and survival temperatures and are also compatible with flammable liquids. The NTSB recognizes that PHMSA will likely need to work with the FRA to assess the availability of gaskets, determine their compatibility with flammable liquids, understand their survivability under pool and torch fire conditions, and develop a benchmark service temperature. Therefore, the NTSB recommends that PHMSA and the FRA work together to develop and publish benchmark service and survival temperatures for gaskets to be used in tank cars used in flammable liquid service that reflect currently available gasket materials. The NTSB also recommends that once a benchmark service and survival temperature is established, PHMSA and the FRA work together to develop and publish thermal performance standards for gaskets used in tank cars in flammable liquid service that address both accident and normal transportation conditions.

2.2.2 Thermal Protection Requirements for DOT-117 Tank Cars

Recent train derailments with pool fires have resulted in damage to tank cars not otherwise breached during the derailment. To mitigate this damage and protect first responders and the public, thermal protection systems must be effective under pool fire conditions. In 2016, 49 *CFR* 179.202.6 set requirements for DOT-117 tank car thermal protection systems by expanding existing thermal protection regulations in 49 *CFR* 179.18 to these tank cars.²⁸ These regulations include performance standards and verification procedures for demonstrating compliance.

The NTSB reviewed the history of PHMSA's (then RSPA's) thermal survivability regulatory requirements in 49 *CFR* 179.18, which were applied to DOT-117 tank cars

²⁸ Hazardous Materials: FAST Act Requirements for Flammable Liquids and Rail Tank Cars. 81 *FR* 53957, August 15, 2016.

through 49 *CFR* 179.202-6 in 2016. The NTSB found that, in 1995, the regulations in 49 *CFR* 179.18 applied to pressure tank cars carrying Division 2.1 (flammable gas) and Division 2.3 (poisonous gas) hazardous materials.²⁹ However, Division 2.1 and Division 2.3 pressure tank cars fall under their own series of DOT specifications and differ significantly from non-pressure general tank cars (which include the DOT-117 and older DOT-111 specifications). For example, pressure tank cars do not have hinged-and-bolted manways, most pressure tank cars do not have bottom outlets, and service equipment on pressure tank cars is usually integrated into the manway cover and covered by a protective housing.³⁰ DOT-117 tank cars commonly have hinged-and-bolted manway covers positioned outside the protective housing in addition to a separate group of top fittings. In addition, although bottom outlet valves and associated fittings are situated within skid protection structures, this equipment is not protected from thermal damage by the thermal protection blanket. These differences increase the amount of DOT-117 tank area not easily covered by a thermal protection blanket that closely follows the contours of the tank. The presence of hinged-and-bolted manway covers and bottom outlet valves also increases the number of tank features vulnerable to thermal damage, as illustrated by the Oklaunion and Raymond derailments and pool fires.

Nevertheless, DOT-117 tank car designs must comply with the same thermal protection regulations as pressure tank cars before receiving a Certificate of Construction. In the case of the DOT-117J tank cars involved in the Oklaunion, Texas, pool fire, the AAR issued a Certificate of Construction on January 23, 2020. The NTSB reviewed Trinity Industries' application for a Certificate of Construction for these tank cars, including the engineering drawings. The drawings showed that the tanks were designed to include a 0.5-inch-thick ceramic thermal protection blanket; however, the tank cars' thermal protection system did not account for the service equipment (such as the manway or bottom outlet) and the protective housing enclosing the top fittings. This design was confirmed by the NTSB during on-scene examinations of the accident tank cars.

The NTSB is concerned that the expansion of the requirements of 49 *CFR* 179.18 to DOT-117 non-pressure general service tank cars in 2016 likely did not consider some relevant differences between pressure tank cars and non-pressure

²⁹ Crashworthiness Protection Requirements for Tank Cars; Detection and Repair of Cracks, Pits, Corrosion, Lining Flaws, Thermal Protection Flaws and Other Defects of Tank Car Tanks. 60 *FR* 49052, September 21, 1995.

³⁰ See 49 *CFR* 179 Subpart C for pressure tank car specifications.

general service tank cars, including requirements for the design and position of service equipment that may not be covered by the thermal protection blanket. Because the tank cars involved in the pool fire used a pre-approved thermal protection system (one originally designed for pressure tank cars), analysis of thermal effects of the entire surface of the accident tank cars was not required. As a result, there was no documentation of thermal effects on the exposed service equipment, whose design differs between DOT-117 tank cars and pressure tank cars. As discussed in section 2.2.1, thermally damaged service equipment and gaskets provided the path of lading leakage for all thermally breached railcars involved in the derailment and subsequent pool fire. Laboratory testing of a nitrile rubber manway cover gasket removed from a tank car not involved in the pool fire showed gasket degradation that would lead to leaks within 15 minutes. The NTSB concludes that PHMSA's 2016 expansion of existing thermal protection system regulations from pressure tank cars to non-pressure DOT-117 tank cars likely did not account for the design differences between these types of tank cars, thus a DOT-117 tank car certified as compliant with regulations may have deficient thermal protection because its service equipment may not be protected by its thermal blanket. The NTSB believes a DOT-117 tank car is only as strong as its weakest part, including exposed features such as manways, bottom outlet valves, and other service equipment, along with their subcomponents, such as gaskets. Regulations governing performance standards for thermal survivability and tank car certification must account for the design differences that could impact these tank cars' ability to meet performance standards. Therefore, the NTSB recommends that PHMSA revise the DOT-117 specification in 49 *CFR* 179.202-6 to ensure that DOT-117 tank cars incorporate thermal protection systems appropriate to non-pressure tank cars so that service equipment is thermally protected. As mentioned above, the AAR is the delegated authority to review applications for Certificates of Construction for DOT-117 tank cars and determine if the tank, equipment, and car fully conform to the specification set by PHMSA regulation. Therefore, the NTSB also recommends that after PHMSA revises the DOT-117 specification, the AAR revise its Certificate of Construction approval procedures for DOT-117 tank cars to ensure use of compliant thermal protection systems.

2.3 Underframe Attachment Welds and the 85 Percent Rule

One tank car involved in the derailment, TILX731751, sustained a mechanical breach to the tank head material despite being near the rear of the derailment pileup where the impact forces between tank cars likely would have been lowest. On-scene examination of the tank car showed that it was involved in three collisions, each of which deformed the tank head. Only the deformation nearest the bottom of the head (and therefore the stub sill) led to a breach. The breach itself was at a weld between

the tank head material and the front sill pad. The observation that the tank car was breached only near the stub sill prompted the NTSB to examine the derailment performance, construction, and design of the underframe attachments that joined the tank to the stub sill.

The NTSB's examination of tank car TILX731751 found that the head brace did not separate from the stub sill, and the front sill pad did not separate from the head brace at the weld. Instead, the front sill pad material fractured at a weld joining it to the head brace, and the tank head material subsequently fractured at the window weld root between the front sill pad and the tank head. (See figure 9.) This suggests the window weld between the front sill pad and the tank continued to provide a load path between the tank head and the stub sill, leading to a local stress state that exceeded the strength of the tank head material. This local stress state caused the tank head material to fracture. In other words, when the window weld on the front sill pad was loaded following the front sill pad fracture, the local stress state led to fracture of the tank head material. Therefore, the NTSB concludes that the mechanical breach of tank car TILX731751 between the tank head material and the front sill pad occurred because the window weld between the front sill pad and the tank continued to provide a load path between the tank head and the stub sill while the head brace remained attached to part of the front sill pad, leading to a local stress state that exceeded the strength of the tank head material.

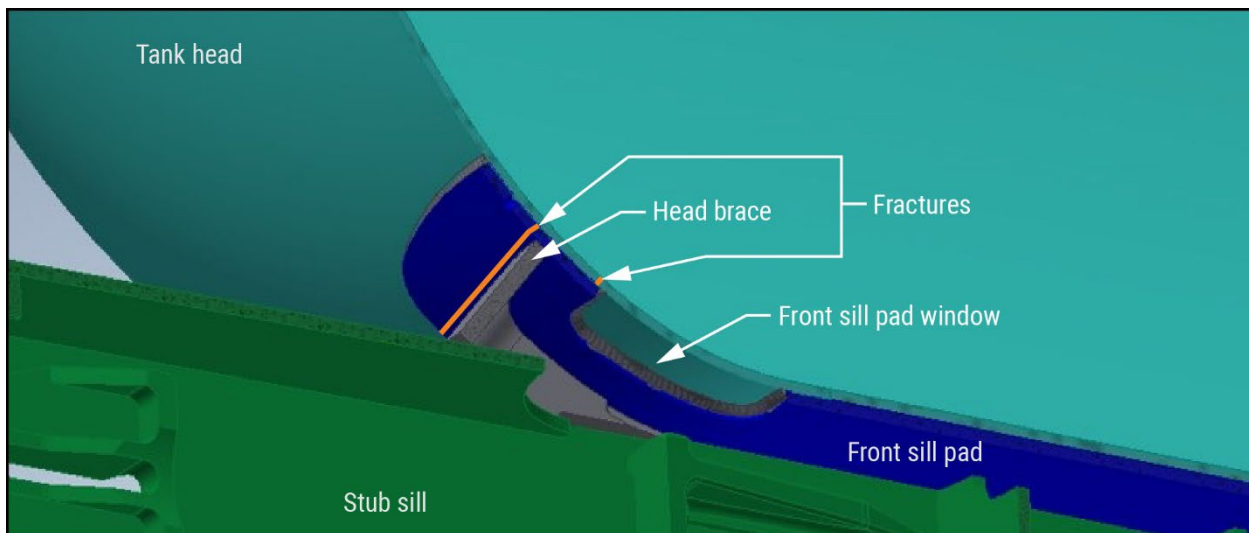

Figure 9. Diagram of fracture locations.

The industry standard version of the 85 percent rule (the AAR 85 percent rule in the MSRP) is intended to prevent this outcome by limiting the ratio between the areas of the welds joining the tank to the sill pads and the areas of welds joining the

sill pads to the stub sill and head brace.³¹ Because weld strength is a function of weld area, an 85 percent ratio between weld areas can reasonably be expected to result in an 85 percent ratio between weld strengths.

Laboratory examination of a sectioned piece of the damage to tank car TILX731751 showed that oversized welds along this load path contributed to the breach. According to a weld design rule of thumb, maximum weld strength on a T-shaped joint (such as the joint between the front of the head brace and the front sill pad) is achieved when the fillet weld leg on each side of the "T" equals three-quarters of the thickness of the thinner member in the joint (Blodgett 1963). This is equivalent to a theoretical throat of about half the thickness of the thinner member. In the weld between the head brace and front sill pad, the thinner member was the pad, which had a thickness of 0.625 inches. By the weld design rule-of-thumb calculation, maximum weld strength would have been achieved with theoretical throats of about 0.331 inches on the inboard and outboard sides of the head brace. To promote failure at the weld rather than the underlying material (that is, a fracture in the metal of the head brace or stub sill pad), the weld at the joint should have been sized to have less than maximum strength. Thus, the welds attaching the head brace to the pad should have had theoretical throats of less than 0.331 inches.

Trinity Industries' design drawings for the fillet welds joining the head brace to the front sill pad fall within the limit set by this calculation; the drawings specify a 0.265-inch weld throat on the outboard side and a 0.177-inch weld throat on the inboard side, which corresponds to an average weld throat of 0.221 inches, or about 35% of the pad thickness. Therefore, by the weld design rule-of-thumb calculation, the as-designed head brace fillet welds should have been more likely to fail than the front sill pad itself, an outcome meant to protect the tank. However, laboratory examinations of a sectioned piece of tank car TILX731751 showed that the tank car had been fabricated with oversized inboard and outboard head-brace-to-pad welds, with effective throats that averaged 0.345 inches and therefore exceeded the design size by an average of 56%. This increased the probability that the thinner member in the joint (the front sill pad), rather than the weld, would fail under load. As the NTSB found during postderailment examinations, the front sill pad fractured while the weld remained intact. The NTSB concludes that because welds between the head brace and front sill pad exceeded their design sizes, the strength of the head brace attachment weld for tank car TILX731751 likely exceeded the load carrying capability

³¹ As discussed in section 1.3.2, the AAR 85 percent rule is the practical application of the federal 85 percent rule.

of the underlying front sill pad, reducing the probability of the weld failing as intended when placed under high loads, such as the ones that occur during a derailment, and resulting in the tank car being mechanically breached.

Similarly, laboratory examinations showed that the window weld exceeded its design size by about 71%, meaning that it also could survive greater loads—and transmit greater loads to the tank head—than the weld specified in the design. The relative strengths of the weld and underlying material caused the window weld to remain intact while the tank head material fractured under load. In other words, because the welds were stronger than the design plan called for, the weakest elements in the load path were the front sill pad and tank head material. While weld design and fabrication practices generally favor creating welds that are at least as strong as the joined elements, tank car design requirements for structural attachments—specifically, the 85 percent rule—are intended to provide specific points of failure by limiting the relative weld strength to protect the underlying components.

The design of the accident tank cars was compliant with the AAR 85 percent rule, as shown by the drawings Trinity Industries provided in support of tank car certification. However, as shown by the laboratory examination of tank car TILX731751, as-built tank cars can have welds exceeding their design sizes. The AWS (American Welding Society) and AAR welding standards that Trinity Industries referenced in its October 27, 2021, letter to the FRA do not include criteria for rejecting oversized welds. The NTSB is concerned that neither the AAR 85 percent rule nor the AWS standard provides a means by which an inspector can reject a weld as too large. Therefore, the NTSB concludes that the weld size specified by a tank car design is effectively a minimum size for the weld on an as-built tank car because industry standards do not provide for the rejection of oversized welds that, if left unaddressed, may lead to tank fractures.

The oversized welds measured on tank car TILX731751 indicate that variations in tank car fabrication can result in a tank car that does not comply with the AAR 85 percent rule even when the design is compliant with the rule and certified. The welds observed on this tank car were not an anomaly. During the FRA's September 22, 2022, inspection of Trinity Industries' Longview, Texas, facility, the FRA inspector observed oversized welds on other tank cars and found that Trinity Industries' quality assurance standards would not identify or reject oversized welds during or after tank car fabrication. Therefore, the NTSB concludes that a tank car design that complies with the AAR 85 percent rule does not prevent tank cars from being fabricated with oversized welds that make the as-built tank cars noncompliant with the rule and more vulnerable to mechanical breaches in a derailment. The NTSB recommends that the AAR revise the inspection requirements for welds associated with the 85 percent rule

contained in the MSRP to include a standard for rejecting oversized welds on as-built tank cars.

3 Conclusions

Findings

1. Gaskets currently used in DOT-117J tank car service equipment may be made of materials vulnerable to thermal damage when exposed to fire, which can lead to the release of hazardous material.
2. Using gaskets with higher service and survival temperatures would likely increase the fire exposure survival time of DOT-117 tank car service equipment in flammable liquid service and reduce the severity of hazardous materials releases.
3. The Pipeline and Hazardous Materials Safety Administration's 2016 expansion of existing thermal protection system regulations from pressure tank cars to non-pressure DOT-117 tank cars likely did not account for the design differences between these types of tank cars, thus a DOT-117 tank car certified as compliant with regulations may have deficient thermal protection because its service equipment may not be protected by its thermal blanket.
4. The mechanical breach of tank car TILX731751 between the tank head material and the front sill pad occurred because the window weld between the front sill pad and the tank continued to provide a load path between the tank head and the stub sill while the head brace remained attached to part of the front sill pad, leading to a local stress state that exceeded the strength of the tank head material.
5. Because welds between the head brace and front sill pad exceeded their design sizes, the strength of the head brace attachment weld for tank car TILX731751 likely exceeded the load carrying capability of the underlying front sill pad, reducing the probability of the weld failing as intended when placed under high loads, such as the ones that occur during a derailment, and resulting in the tank car being mechanically breached.
6. The weld size specified by a tank car design is effectively a minimum size for the weld on an as-built tank car because industry standards do not provide for the rejection of oversized welds that, if left unaddressed, may lead to tank fractures.

7. A tank car design that complies with the Association of American Railroads 85 percent rule does not prevent tank cars from being fabricated with oversized welds that make the as-built tank cars noncompliant with the rule and more vulnerable to mechanical breaches in a derailment.

4 Recommendations

New Recommendations

As a result of this investigation, the National Transportation Safety Board makes the following new safety recommendations.

To the Federal Railroad Administration:

Work with the Pipeline and Hazardous Materials Safety Administration to develop and publish benchmark service and survival temperatures for gaskets to be used in tank cars used in flammable liquid service that reflect currently available gasket materials. (R-23-12)

Work with the Pipeline and Hazardous Materials Safety Administration to develop and publish thermal performance standards for gaskets used in tank cars in flammable liquid service that address both accident and normal transportation conditions. (R-23-13)

To the Pipeline and Hazardous Materials Safety Administration:

Work with the Federal Railroad Administration to develop and publish benchmark service and survival temperatures for gaskets to be used in tank cars used in flammable liquid service that reflect currently available gasket materials. (R-23-14)

Work with the Federal Railroad Administration to develop and publish thermal performance standards for gaskets used in tank cars in flammable liquid service that address both accident and normal transportation conditions. (R-23-15)

Revise the DOT-117 specification in 49 *Code of Federal Regulations* 179.202-6 to ensure that DOT-117 tank cars incorporate thermal protection systems appropriate to non-pressure tank cars so that service equipment is thermally protected. (R-23-16)

To the Association of American Railroads:

After the Pipeline and Hazardous Materials Safety Administration revises the DOT-117 specification, revise your Certificate of Construction approval procedures for DOT-117 tank cars to ensure use of compliant thermal protection systems. (R-23-17)

Revise the inspection requirements for welds associated with the 85 percent rule contained in the Manual of Standards and Recommended Practices to include a standard for rejecting oversized welds on as-built tank cars. (R-23-18)

BY THE NATIONAL TRANSPORTATION SAFETY BOARD

JENNIFER HOMENDY

Chair

BRUCE LANDSBERG

Member

MICHAEL GRAHAM

Member

THOMAS CHAPMAN

Member

Report Date: September 27, 2023

Appendixes

Appendix A: Investigation

The National Transportation Safety Board (NTSB) was notified on January 8, 2022, of the derailment, in which eastbound BNSF Railway Company (BNSF) train U-JOENYF7-07A, derailed 37 tank cars at milepost 156.2 on the BNSF Red River Division in Oklaunion, Texas. The train was carrying denatured ethanol, a flammable liquid, in US Department of Transportation specification 117J tank cars. Twenty-eight of the 37 derailed tank cars became involved in a pool fire that burned uncontrolled for about 4 hours. BNSF estimated that 601,819 gallons of denatured ethanol were released. No injuries or evacuations were reported.

The NTSB launched an investigator-in-charge and a team to investigate the performance of the tank cars during the derailment and pool fire.

Parties to the investigation included the Federal Railroad Administration, the Pipeline and Hazardous Materials Safety Administration, BNSF, and the Trinity Industries Leasing Company.

Appendix B: Consolidated Recommendation Information

Title 49 *United States Code* 1117(b) requires the following information on the recommendations in this report.

For each recommendation—

(1) a brief summary of the Board's collection and analysis of the specific accident investigation information most relevant to the recommendation;

(2) a description of the Board's use of external information, including studies, reports, and experts, other than the findings of a specific accident investigation, if any were used to inform or support the recommendation, including a brief summary of the specific safety benefits and other effects identified by each study, report, or expert; and

(3) a brief summary of any examples of actions taken by regulated entities before the publication of the safety recommendation, to the extent such actions are known to the Board, that were consistent with the recommendation.

To the Federal Railroad Administration:

R-23-12

Work with the Pipeline and Hazardous Materials Safety Administration to develop and publish benchmark service and survival temperatures for gaskets to be used in tank cars used in flammable liquid service that reflect currently available gasket materials.

Information that addresses the requirements of 49 *USC* 1117(b), as applicable, can be found in section 2.2.1, Gasket Service Temperatures. Information supporting (b)(1) and (b)(2) can be found on pages 18-22; (b)(3) is not applicable.

R-23-13

Work with the Pipeline and Hazardous Materials Safety Administration to develop and publish thermal performance standards for gaskets used in tank cars in flammable liquid service that address both accident and normal transportation conditions.

Information that addresses the requirements of 49 *USC* 1117(b), as applicable, can be found in section 2.2.1, Gasket Service Temperatures. Information supporting (b)(1) and (b)(2) can be found on pages 18-22; (b)(3) is not applicable.

To the Pipeline and Hazardous Materials Safety Administration:**R-23-14**

Work with the Federal Railroad Administration to develop and publish benchmark service and survival temperatures for gaskets to be used in tank cars used in flammable liquid service that reflect currently available gasket materials.

Information that addresses the requirements of 49 *USC* 1117(b), as applicable, can be found in section 2.2.1, Gasket Service Temperatures. Information supporting (b)(1) and (b)(2) can be found on pages 18-22; (b)(3) is not applicable.

R-23-15

Work with the Federal Railroad Administration to develop and publish thermal performance standards for gaskets used in tank cars in flammable liquid service that address both accident and normal transportation conditions.

Information that addresses the requirements of 49 *USC* 1117(b), as applicable, can be found in section 2.2.1, Gasket Service Temperatures. Information supporting (b)(1) and (b)(2) can be found on pages 18-22; (b)(3) is not applicable.

R-23-16

Revise the DOT-117 specification in 49 *Code of Federal Regulations* 179.202-6 to ensure that DOT-117 tank cars incorporate thermal protection systems appropriate to non-pressure tank cars so that service equipment is thermally protected.

Information that addresses the requirements of 49 *USC* 1117(b), as applicable, can be found in section 2.2, Thermal Damage. Information supporting (b)(1) can be found on pages 18-19 and 24; (b)(2) can be found on pages 18-22; and (b)(3) is not applicable.

To the Association of American Railroads:**R-23-17**

After the Pipeline and Hazardous Materials Safety Administration revises the DOT-117 specification, revise your Certificate of Construction

approval procedures for DOT-117 tank cars to ensure use of compliant thermal protection systems.

Information that addresses the requirements of 49 *USC* 1117(b), as applicable, can be found in section 2.2, Thermal Damage. Information supporting (b)(1) can be found on pages 18-19 and 24; (b)(2) can be found on pages 18-22; and (b)(3) is not applicable.

R-23-18

Revise the inspection requirements for welds associated with the 85 percent rule contained in the Manual of Standards and Recommended Practices to include a standard for rejecting oversized welds on as-built tank cars.

Information that addresses the requirements of 49 *USC* 1117(b), as applicable, can be found in section 2.3, Underframe Attachment Welds and the 85 Percent Rule. Information supporting (b)(1) can be found on pages 24-27; (b)(2) can be found on pages 27-28; and (b)(3) is not applicable.

References

- AAR (Association of American Railroads). 2015. MSRP (Manual of Standards and Recommended Practices) Section C-II, *Design, Fabrication, and Construction of Freight Cars*, paragraph 6.1.2.4.1. Washington, DC: AAR.
- AAR. 2014a. MSRP Section C-III, Specification M-1002. Washington, DC: AAR.
- AAR. 2014b. MSRP Section C-III, Appendix W. Washington, DC: AAR.
- AWS (American Welding Society). 2019. AWS D15.1/D15.1M:2019, *Railroad Welding Specification for Cars and Locomotives*. 6th Edition. Danvers, Massachusetts: AWS.
- Blodgett, O.W. 1963. *Design of Weldments*. Cleveland, Ohio: James F. Lincoln Arc Welding Foundation.
- NTSB (National Transportation Safety Board). 1988. Butadiene Release and Fire from GATX 55996 at the CSX Terminal Junction Interchange, New Orleans, Louisiana, September 8, 1987. NTSB/HZM-88/01. Washington, DC: NTSB.

The NTSB is an independent federal agency charged by Congress with investigating every civil aviation accident in the United States and significant events in the other modes of transportation—railroad, transit, highway, marine, pipeline, and commercial space. We determine the probable causes of the accidents and events we investigate and issue safety recommendations aimed at preventing future occurrences. In addition, we conduct transportation safety research studies and offer information and other assistance to family members and survivors for each accident or event we investigate. We also serve as the appellate authority for enforcement actions involving aviation and mariner certificates issued by the Federal Aviation Administration (FAA) and US Coast Guard, and we adjudicate appeals of civil penalty actions taken by the FAA.

The NTSB does not assign fault or blame for an accident or incident; rather, as specified by NTSB regulation, “accident/incident investigations are fact-finding proceedings with no formal issues and no adverse parties ... and are not conducted for the purpose of determining the rights or liabilities of any person” (Title 49 *Code of Federal Regulations* section 831.4). Assignment of fault or legal liability is not relevant to the NTSB’s statutory mission to improve transportation safety by investigating accidents and incidents and issuing safety recommendations. In addition, statutory language prohibits the admission into evidence or use of any part of an NTSB report related to an accident in a civil action for damages resulting from a matter mentioned in the report (Title 49 *United States Code* section 1154(b)).

For more detailed background information on this report, visit the [NTSB Case Analysis and Reporting Online \(CAROL\) website](#) and search for NTSB accident ID HMD22LR001. Recent publications are available in their entirety on the [NTSB website](#). Other information about available publications also may be obtained from the website or by contacting—

National Transportation Safety Board
Records Management Division, CIO-40
490 L’Enfant Plaza, SW
Washington, DC 20594
(800) 877-6799 or (202) 314-6551

Copies of NTSB publications may be downloaded at no cost from the National Technical Information Service, at the National Technical Reports Library search page, using product number PB2023-100110. For additional assistance, contact—

National Technical Information Service
5301 Shawnee Rd.
Alexandria, VA 22312
(800) 553-6847 or (703) 605-6000
[NTIS website](#)