



NATIONAL TRANSPORTATION SAFETY BOARD
Investigative Hearing

Norfolk Southern Railway general merchandise freight train 32N
derailment with subsequent hazardous material release and fires,
in East Palestine, Ohio, on February 3, 2023

GROUP	H
EXHIBIT	
21	

Agency / Organization

Norfolk Southern

Title

**DOT FRA Field Product Removal Methods
for Tank Cars (Feb. 1993)**



U.S. Department
of Transportation
**Federal Railroad
Administration**

FIELD PRODUCT REMOVAL METHODS FOR TANK CARS

**Office of Research and
Development
Washington D.C. 20590**

DOT/FRA/ORD/92-27

**February 1993
Final Report**

**This document is available to the
U.S. public through the National
Technical Information Service
Springfield, Virginia 22161**

1. Report No. FRA/ORD/92-27	2. Government Accession No.	3. Recipient's Catalog No.	
4. Title and Subtitle FIELD PRODUCT REMOVAL METHODS FOR TANK CARS		5. Report Date December, 1991.	
		6. Performing Organization Code AAR/TTC	
7. Author(s) R.K. Larson Jr., AAR Staff Engineer M.N. McCulloch, Former AAR HAZMAT Instructor J.C. Davis, Current AAR HAZMAT Manager		8. Performing Organization Report No.	
		10. Work Unit No. (TRAIS)	
9. Performing Organization Name and Address Association of American Railroads Transportation Test Center P.O. Box 11130 Pueblo, CO 81001		11. Contract or Grant No. DTFR53-82-C-00282 Task Order #31	
		13. Type of Report or Period Covered January 1988 through June 1992	
12. Sponsoring Agency Name and Address U.S. Department of Transportation Federal Railroad Administration Office of Research and Development Washington, D.C. 20590		14. Sponsoring Agency Code RDV 32	
		15. Supplementary Notes	
16. Abstract The Association of American Railroads (AAR) has prepared a handbook entitled "Field Product Removal Methods for Tank Cars" containing guidelines for use by responders to derailments involving tank cars. The handbook was prepared by the AAR's Hazardous Materials Training Center and by AAR engineering staff after reviewing guidelines developed during a symposium held January 19 - 20, 1988 at the Transportation Test Center. The handbook presents several general techniques for unloading damaged tank cars. Procedures for implementing each of the techniques are given along with a list of required equipment. Typical applications are described for each of the techniques and a list of safety precautions is provided. The techniques described in the handbook have evolved from the experience of persons who have responded to derailments involving tank cars carrying hazardous materials. These techniques are recognized to have utility in an emergency situation where a tank car has been damaged to the extent that it cannot be moved to an appropriate unloading point. In such situations, selecting the appropriate unloading technique and implementing the technique using established procedures can have an important bearing on the overall safety of a derailment response.			
17. Key Words TRAIN DERAILMENT RESPONSE PRESSURE AND NON-PRESSURE TANK CARS HAZARDOUS MATERIALS TANK CAR UNLOADING PROCEDURES TRANSFER, VENTING, FLARING, VENT AND BURN, HOT TAPPING,		18. Distribution Statement This document is available through National Technical Information Service Springfield, VA 22161	
19. Security Classification (of the report) NONCLASSIFIED	20. Security Classification (of this page) NONCLASSIFIED	21. No. of Pages 175	22. Price

METRIC CONVERSION FACTORS

Approximate Conversions to Metric Measures

Symbol	When You Know	Multiply by	To Find	Symbol
--------	---------------	-------------	---------	--------

LENGTH

in	inches	*2.50	centimeters	cm
ft	feet	30.00	centimeters	cm
yd	yards	0.90	meters	m
mi	miles	1.60	kilometers	km

AREA

in ²	square inches	6.50	square centimeters	cm ²
ft ²	square feet	0.09	square meters	m ²
yd ²	square yards	0.80	square meters	m ²
mi ²	square miles	2.60	square kilometers	km ²
	acres	0.40	hectares	ha

MASS (weight)

oz	ounces	28.00	grams	g
lb	pounds	0.45	kilograms	kg
	short tons	0.90	tonnes	t
	(2000 lb)			

VOLUME

tsp	teaspoons	5.00	milliliters	ml
Tbsp	tablespoons	15.00	milliliters	ml
fl oz	fluid ounces	30.00	milliliters	ml
c	cups	0.24	liters	l
pt	pints	0.47	liters	l
qt	quarts	0.95	liters	l
gal	gallons	3.80	liters	l
ft ³	cubic feet	0.03	cubic meters	m ³
yd ³	cubic yards	0.76	cubic meters	m ³

TEMPERATURE (exact)

°F	Fahrenheit temperature	5/9 (after subtracting 32)	Celsius temperature	°C
----	------------------------	----------------------------	---------------------	----

Approximate Conversions from Metric Measures

Symbol	When You Know	Multiply by	To Find	Symbol
--------	---------------	-------------	---------	--------

LENGTH

mm	millimeters	0.04	inches	in
cm	centimeters	0.40	inches	in
m	meters	3.30	feet	ft
m	meters	1.10	yards	yd
km	kilometers	0.60	miles	mi

AREA

cm ²	square centim.	0.16	square inches	in ²
m ²	square meters	1.20	square yards	yd ²
km ²	square kilom.	0.40	square miles	mi ²
ha	hectares	2.50	acres	
	(10,000 m ²)			

MASS (weight)

g	grams	0.035	ounces	oz
kg	kilograms	2.2	pounds	lb
t	tonnes (1000 kg)	1.1	short tons	

VOLUME

ml	milliliters	0.03	fluid ounces	fl oz
l	liters	2.10	pints	pt
l	liters	1.06	quarts	qt
l	liters	0.26	gallons	gal
m ³	cubic meters	36.00	cubic feet	ft ³
m ³	cubic meters	1.30	cubic yards	yd ³

TEMPERATURE (exact)

°C	Celsius temperature	9/5 (then add 32)	Fahrenheit temperature	°F
----	---------------------	-------------------	------------------------	----

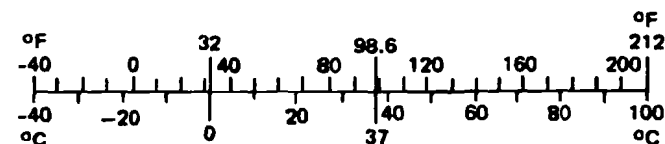
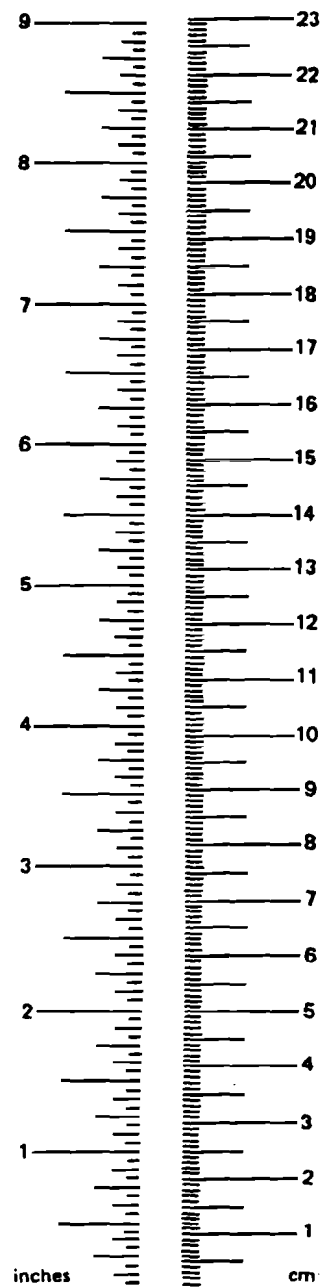

* 1 in. = 2.54 cm (exactly)

Temperature Conversion Table

'F	'C	'F	'C	'F	'C
-40	-40	180	82.2	400	204.4
-35	-37.2	185	85.0	405	207.2
-30	-34.4	190	87.8	410	210.0
-25	-31.6	195	90.5	415	212.8
-20	-28.9	200	93.3	420	215.5
-15	-26.1	205	96.1	425	218.3
-10	-23.3	210	98.9	430	221.1
-5	-20.5	212	100.0	435	223.9
0	-17.78	215	101.6	440	226.6
+5	-15.0	220	104.4	445	229.4
10	-12.2	225	107.2	450	232.2
15	-9.4	230	110.0	455	235.0
20	-6.6	235	112.8	460	237.8
25	-3.9	240	115.5	465	240.5
30	-1.1	245	118.3	470	243.3
32	0	250	121.1	475	246.1
35	+1.6	255	123.9	480	248.9
40	4.4	260	126.6	485	251.6
45	7.2	265	129.4	490	254.4
50	10.0	270	132.2	495	257.2
55	12.8	275	135.0	500	260.0
60	15.5	280	137.8	550	287.8
65	18.3	285	140.5	600	315.5
70	21.1	290	143.3	650	343.3
75	23.9	295	146.1	700	371.1
80	26.6	300	148.9	750	398.9
85	29.4	305	151.6	800	426.6
90	32.2	310	154.4	850	454.4
95	35	315	157.2	900	482.2
100	37.8	320	160.0	950	510.0
105	40.5	325	162.8	1000	537.8
110	43.3	330	165.5	1100	593.3
115	46.1	335	168.3	1200	648.9
120	48.9	340	171.1	1300	704.4
125	51.6	345	173.9	1400	760.0
130	54.4	350	176.6	1500	815.5
135	57.2	355	179.4	1600	871.1
140	60.0	360	182.2	1700	926.6
145	62.8	365	185.0	1800	982.2
150	65.5	370	187.8	1900	1037.8
155	68.3	375	190.5	2000	1093.3
160	71.1	380	193.3		
165	73.9	385	196.1		
170	76.6	390	198.9		
175	79.4	395	201.6		

$$^{\circ}\text{C} = (^{\circ}\text{F} - 32) \times 5/9 \text{ (or } 0.55)$$

$$^{\circ}\text{F} = ^{\circ}\text{C} \times 9/5 \text{ (or } 1.8) + 32$$

Table of Contents

Table of Figures	ix
Foreword	xi
Section 1: Introduction	
Overview	1
<i>Gas Transfer Methods</i>	
Overview	2
Gas Transfer Using a Vapor Compressor	2
Gas Transfer Using a Liquid Pump	2
Gas Transfer Using a Liquid Pump and a Vapor Compressor	3
Gas Transfer Using an Inert Gas	3
Gas Transfer Using Vapor Pressure and Flaring	3
<i>Liquid Transfer Methods</i>	
Overview	4
Liquid Transfer Using a Liquid Pump	4
<i>Product-Removal Methods</i>	
Overview	5
Vapor Flaring	5
Liquid Flaring	5
Venting	5
Vent and Burn Operations	5
Hot Tap	6
 <i>Gas Transfer Methods</i>	
Section 2: Gas Transfer Using a Vapor Compressor	
Overview	7
Preferred Conditions	8
Potential Risks	8
Safety Precautions	9
Required Equipment	
Tools and Supplies	11
Fittings and Other Gas Transfer Equipment	12
General Procedures	
Plan the Gas Transfer Operation	16
Set Up the Gas Transfer Operation	17
Implement the Gas Transfer Operation	20
Shut Down the Gas Transfer Operation	22

Table of Contents *(continued)*

Section 3: Gas Transfer Using a Liquid Pump

Overview _____	25
Preferred Conditions _____	26
Potential Risks _____	26
Safety Precautions _____	27
Required Equipment	
Tools and Supplies _____	29
Fittings and Other Gas Transfer Equipment _____	30
General Procedures	
Plan the Gas Transfer Operation _____	34
Set Up the Gas Transfer Operation _____	35
Implement the Gas Transfer Operation _____	38
Shut Down the Gas Transfer Operation _____	39

Section 4: Gas Transfer Using a Liquid Pump and a Vapor Compressor

Overview _____	41
Preferred Conditions _____	42
Potential Risks _____	42
Safety Precautions _____	43
Required Equipment	
Tools and Supplies _____	45
Fittings and Other Gas Transfer Equipment _____	46
General Procedures	
Plan the Gas Transfer Operation _____	50
Set Up the Gas Transfer Operation _____	51
Implement the Gas Transfer Operation _____	54
Shut Down the Gas Transfer Operation _____	55

Section 5: Gas Transfer Using an Inert Gas

Overview _____	57
Preferred Conditions _____	58
Potential Risks _____	58
Safety Precautions _____	59
Required Equipment	
Tools and Supplies _____	61
Fittings and Other Gas Transfer Equipment _____	62
General Procedures	
Plan the Gas Transfer Operation _____	66
Set Up the Gas Transfer Operation _____	67
Implement the Gas Transfer Operation _____	71
Shut Down the Gas Transfer Operation _____	72

Table of Contents *(continued)*

Section 6: Gas Transfer Using Product Vapor Pressure and Flaring

Overview _____	75
Preferred Conditions _____	76
Potential Risks _____	76
Safety Precautions _____	77
Required Equipment	
Tools and Supplies _____	79
Fittings and Other Gas Transfer and Flaring Equipment _____	80
General Procedures	
Plan the Gas Transfer Operation _____	84
Set Up the Gas Transfer Operation _____	85
Implement the Gas Transfer Operation _____	88
Shut Down the Gas Transfer Operation _____	89

Liquid Transfer Methods

Section 7: Liquid Transfer Using a Liquid Pump

Overview _____	91
Preferred Conditions _____	92
Potential Risks _____	92
Safety Precautions _____	93
Required Equipment	
Tools and Supplies _____	95
Fittings and Other Liquid Transfer Equipment _____	96
General Procedures	
Plan the Liquid Transfer Operation _____	100
Set Up the Liquid Transfer Operation _____	101
Implement the Liquid Transfer Operation _____	105
Shut Down the Liquid Transfer Operation _____	106

Product-Removal Methods

Section 8: Vapor Flaring

Overview _____	109
Preferred Conditions _____	110
Potential Risks _____	110
Safety Precautions _____	111
Required Equipment	
Tools and Supplies _____	113
Fittings and Other Vapor Flaring Equipment _____	114
General Procedures	
Plan the Vapor Flaring Operation _____	117
Set Up the Vapor Flaring Operation _____	118
Implement the Vapor Flaring Operation _____	120
Shut Down the Vapor Flaring Operation _____	120

Table of Contents *(continued)*

Section 9: Liquid Flaring

Overview _____	121
Preferred Conditions _____	122
Potential Risks _____	122
Safety Precautions _____	123
Required Equipment	
Tools and Supplies _____	125
Fittings and Other Liquid Flaring Equipment _____	126
General Procedures	
Plan the Liquid Flaring Operation _____	128
Set Up the Liquid Flaring Operation _____	128
Implement the Liquid Flaring Operation _____	130
Shut Down the Liquid Flaring Operation _____	131

Section 10: Venting

Overview _____	133
Preferred Conditions _____	134
Potential Risks _____	134
Safety Precautions _____	135
Required Equipment	
Tools and Supplies _____	136
Fittings, Hose, and Venting Equipment _____	137
General Procedures	
Plan the Venting Operation _____	139
Set Up the Venting Operation _____	139
Implement the Venting Operation _____	141
Shut Down the Venting Operation _____	141

Section 11: Vent and Burn

Overview _____	143
Preferred Conditions _____	144
Inherent Risks _____	144
Safety Precautions _____	145
Required Equipment	
Tools and Supplies _____	146
General Procedures	
Plan the Vent and Burn Operation _____	148
Set Up the Vent and Burn Operation _____	148
Implement the Vent and Burn Operation _____	149
Shut Down the Vent and Burn Operation _____	149

Table of Contents *(continued)*

Section 12: Hot Tap

Overview _____	151
Preferred Conditions _____	152
Potential Risks _____	152
Safety Precautions _____	153
Required Equipment	
Tools and Supplies _____	154
General Procedures	
Plan the Hot Tap Operation _____	156
Set Up the Hot Tap Operation _____	156
Implement the Hot Tap Operation _____	157
Appendix A: Symposium Attendees _____	159

This page left blank intentionally

Table of Figures

Section 2: Gas Transfer Using a Vapor Compressor

2-1	Liquid Valve Outlet Assembly for the Damaged Tank Car	14
2-2	Liquid Valve Inlet Assembly for the Receiving Tank _____	14
2-3	Vapor Outlet Assembly for the Receiving Tank _____	14
2-4	Vapor Valve Inlet Assembly for the Damaged Tank Car _	15
2-5	Gas Transfer Using a Vapor Compressor _____	15

Section 3: Gas Transfer Using a Liquid Pump

3-1	Liquid Valve Outlet Assembly for the Damaged Tank Car	32
3-2	Liquid Valve Inlet Assembly for the Receiving Tank _____	32
3-3	Vapor Valve Outlet Assembly for the Receiving Tank _	32
3-4	Vapor Valve Inlet Assembly for the Damaged Tank Car _	33
3-5	Gas Transfer Using a Liquid Pump _____	33

Section 4: Gas Transfer Using a Liquid Pump and a Vapor Compressor

4-1	Liquid Valve Outlet Assembly for the Damaged Tank Car	48
4-2	Liquid Valve Inlet Assembly for the Receiving Tank _____	48
4-3	Vapor Valve Outlet Assembly for the Receiving Tank _	48
4-4	Vapor Valve Inlet Assembly for the Damaged Tank Car _	49
4-5	Gas Transfer Using a Liquid Pump and a Vapor Compressor _____	49

Section 5: Gas Transfer Using an Inert Gas

5-1	Liquid Valve Outlet Assembly for the Damaged Tank Car	64
5-2	Liquid Valve Inlet Assembly for the Receiving Tank _____	64
5-3	Vapor Valve Outlet Assembly for the Receiving Tank _	64
5-4	Vapor Valve Inlet Assembly for the Damaged Tank Car _	65
5-5	Gas Transfer Using an Inert Gas _____	65

Section 6: Gas Transfer Using Product Vapor Pressure and Flaring

6-1	Liquid Valve Outlet Assembly for the Damaged Tank Car	82
6-2	Liquid Valve Inlet Assembly for the Receiving Tank _____	82
6-3	Vapor Valve Outlet Assembly for the Receiving Tank _	82
6-4	Vapor Valve Inlet Assembly for the Damaged Tank Car _	83
6-5	Gas Transfer Using Product Vapor Pressure and Flaring (with optional use of inert gas) _____	83

Table of Figures *(continued)*

Section 7: Liquid Transfer Using a Liquid Pump

7-1	Liquid Valve Outlet Assembly for the Damaged Tank Car _____	98
7-2	Liquid Valve Inlet Assembly for the Receiving Tank _____	98
7-3	Air Valve Outlet Assembly for the Receiving Tank _____	98
7-4	Air Valve Inlet Assembly for the Damaged Tank Car _____	99
7-5	Liquid Transfer Using a Liquid Pump _____	99

Section 8: Vapor Flaring

8-1	Vapor Valve Outlet Assembly for the Damaged Tank Car _____	115
8-2	Vapor Flaring Operation _____	115
8-3	Flare Stand _____	116

Section 9: Liquid Flaring

9-1	Liquid Valve Outlet Assembly for the Damaged Tank Car _____	127
9-2	Liquid Flaring Operation _____	127

Section 10: Venting

10-1	Vapor Valve Outlet Assembly for the Damaged Tank Car _____	138
10-2	Venting Operation _____	138

Section 11: Vent and Burn

11-1	Vent and Burn Operation _____	147
------	-------------------------------	-----

Section 12: Hot Tap

12-1	Hot Tap Machine (Drilling Machine) _____	155
------	--	-----

Foreword

This handbook presents several general methods for unloading damaged tank cars in the field. Each section of the handbook consists of an overview of each method, preferred conditions that should exist or be met before a particular option is selected, potential risks associated with the procedure, necessary safety precautions, a list of equipment required, and procedures for implementing the method and for shutting down the operation.

This document is based on information developed during a symposium held at the Association of American Railroads' Hazardous Materials Emergency Response Training Center in Pueblo, Colorado, on January 19-20, 1988. The symposium was sponsored by the Federal Railroad Administration. Attendees are listed in Appendix A. The Association of American Railroads gratefully acknowledges the contribution these dedicated professionals have made to the production of this handbook. In addition to those listed in Appendix A, special recognition is extended to Mr. C. J. Wright, Manager, Hazardous Materials Training, of the Union Pacific Railroad, and Mr. A. D. Maty, Chief Inspector, AAR Bureau of Explosives, for their help in compiling and editing the final version of this handbook.

All the techniques described in the handbook have been used successfully in the field, usually in situations where a tank car has been damaged to the extent that it cannot safely be railed and moved to an appropriate unloading point. In such situations, selecting the appropriate unloading method and safely implementing it using established procedures can have an important bearing on the successful resolution of the incident.

The reader should note that the handbook describes typical equipment and procedures that might be used in a given operation. Actual equipment and procedures used will vary according to the product involved, the specifications of the tank car containing the product, and other factors that are unique to each situation.

There is no substitute for the good judgment of those in the field.

This page left blank intentionally

Overview

Field product removal methods are those techniques used for removing the contents from a damaged or overloaded tank car in the field. These methods include:

- Transferring liquefied gases or liquids;
- Flaring vapors and/or liquids;
- Venting gases/vapors; and
- Vent and burn.

In addition, this document discusses a method for gaining access to the contents of a tank car when damage to the valves and fittings precludes normal access. This method (hot tap) is used in conjunction with other field product removal methods (i.e., transfer, flaring, or venting).

The techniques, procedures, and equipment described in this handbook should be considered as recommendations. Since each situation is unique, it may not necessarily be unsafe or impractical to deviate from these recommendations. Such decisions are best made by those at the scene who are knowledgeable about the product and the equipment involved.

Under no circumstances should these operations be attempted without a thorough understanding of the product(s) involved. The preferred situation would be to have a representative of the product manufacturer participate in the transfer/removal operation.

These product removal methods are considered outside the legitimate responsibility of the local emergency responder; however, oversight of the planning and implementation of these methods is within the realm of responsibility of local emergency response agencies.

Gas Transfer Methods

Overview

Typically, transfers in the field are distinguished by the basic equipment used to move the contents from the damaged or overloaded tank car. Gas transfers can be accomplished in the field using one of the following methods:

- For an overloaded or damaged tank car where an increase in internal pressure is acceptable:
 - Gas transfer using a vapor compressor;
 - Gas transfer using a vapor compressor and a liquid pump; or
 - Gas transfer using an inert gas.
- For an overloaded or damaged tank car where *no* increase in internal pressure is acceptable:
 - Gas transfer using a liquid pump; or
 - Gas transfer using vapor pressure (with or without flaring).

Gas Transfer Using a Vapor Compressor

(See Section 2, page 7)

This transfer method uses a vapor compressor to move the contents of a damaged or overloaded tank car to a receiving tank (e.g., a tank car, cargo tank, or portable tank). The vapor compressor creates a positive pressure differential by pulling the vapors from the receiving tank, compressing them, and forcing them into the damaged tank car. The pressure in the damaged tank car pushes the liquefied gas into the receiving tank.

Gas Transfer Using a Liquid Pump

(See Section 3, page 25)

This transfer method uses a liquid pump to move the contents of a damaged or overloaded tank car to a receiving tank (e.g., a tank car, cargo tank, or portable tank). Pressure is equalized between the damaged tank car and the receiving tank by connecting a hose to the vapor valves of each car. Then, the product is pumped from the damaged tank car to the receiving tank.

Gas Transfer Using a Liquid Pump and a Vapor Compressor

(See Section 4, page 41)

This transfer method uses a liquid pump to move the contents of a damaged or overloaded tank car to a receiving tank (e.g., a tank car, cargo tank, or portable tank). The rate of transfer is accelerated by using a vapor compressor to create a pressure differential by withdrawing vapors from the receiving tank, compressing them, and forcing them into the damaged tank car. The pressure in the damaged tank car helps keep the pump primed.

Gas Transfer Using an Inert Gas

(See Section 5, page 57)

This transfer method uses an inert gas compatible with the product (e.g., nitrogen or carbon dioxide) to move the contents of a damaged tank car to a receiving tank (e.g., a tank car, cargo tank, or portable tank). The inert gas creates a pressure differential and pushes the liquid into the receiving tank. Vapor from the receiving tank may need to be vented or scrubbed.

Gas Transfer Using Product Vapor Pressure and Flaring

(See Section 6, page 75)

This transfer method uses the vapor pressure of the contents to move the contents of a damaged or overloaded tank car to a receiving tank (e.g., a tank car, cargo tank, or portable tank). The vapor pressure in the damaged tank car pushes the product into the receiving tank. The pressure differential between the damaged tank car and the receiving tank is maintained by burning off vapors from the receiving tank at the outlet of a flare pipe (see Vapor Flaring, Section 8). The pressure in the receiving tank is kept as low as possible. The transfer method is accelerated by introducing an inert gas into the damaged tank car as the pressure drops. This transfer is used only for flammable gases.

Liquid Transfer Methods

Overview

Because of the wide range of products, valve and fitting arrangements, and situations, it is impractical to specify all of the combinations of equipment that may be used to perform a liquid transfer. Persons contemplating a liquid transfer must make their own equipment list based upon consultation with the shipper, their own analysis of the appropriate methods, and the equipment available. Other considerations include properties of the product, and of other non-metallic parts (gaskets, seals, etc.).

Liquid Transfer Using a Liquid Pump

(See Section 7, page 91)

This transfer method uses a pump to move the contents of a damaged tank car to a receiving tank (e.g., a tank car, cargo tank, or portable tank). Pressure may be equalized between the damaged tank car and the receiving tank by connecting a hose to the vapor valves of each car, or by venting to the atmosphere. Then, the product is pumped from the damaged tank car to the receiving tank.

Product-Removal Methods

Overview

Sections 8-12 describe options available to the responder to reduce pressure in a tank car, dispose of a product, or gain access to the contents of a tank car when conventional transfer methods are not feasible due to damage, safety constraints, or other factors.

Vapor Flaring

(See Section 8, page 109)

Vapor flaring is the burning of vapors of a liquefied flammable compressed gas at the outlet of a flare pipe as they exit the pipe. A vertical or horizontal flare pipe can be used.

Liquid Flaring

(See Section 9, page 121)

Liquid flaring is the vaporizing of flammable liquid product and burning the vapors at the end of a horizontal flare pipe. A pit is used to contain any product which is not completely burned.

Venting

(See Section 10, page 133)

Venting is the process of releasing non-flammable, liquefied compressed gas vapors into the atmosphere. This release can be direct or, in case of toxic products, indirect through an appropriate treatment system. Typically, venting is done with nonflammable gases.

Vent and Burn

(See Section 11, page 143)

Vent and burn is the process of using explosive charges to cut a hole (or holes) in a tank car and allowing the product to flow into a pit for burn-off. Because of its inherent risks, vent and burn is considered to be the last viable option for product removal.

Product-Removal Methods *(continued)*

Hot Tap

(See Section 12, page 151)

The hot tap is a method of providing access to the contents of a tank car when damage to the valves and fittings precludes access to the contents. Once the hot tap is completed, transfer, flaring, or venting can take place.

Hot tapping involves the welding of a threaded nozzle onto an undamaged section of the tank that is in contact with the liquid. A liquid high-pressure ball valve is attached to the nozzle. A hole is then drilled through the tank with a special drilling machine. The drilling machine is equipped with seals that prevent loss of product during the drilling operation. Liquid hoses or pipe can be attached to the valve/outlet.

Section 2

Gas Transfer Using a Vapor Compressor

Overview

This transfer method uses a vapor compressor to move the contents of a damaged or overloaded tank car into a receiving tank (e.g., a tank car, cargo tank, or portable tank). The vapor compressor creates a positive pressure differential to move the product by pulling vapors from the receiving tank, compressing them, and forcing them into the damaged tank car. The pressure in the damaged tank pushes the product from the damaged tank into the recovery tank.

The gas transfer using a vapor compressor may be used when:

- The tank car tank itself is sound; however, due to bolster or other mechanical damage, the car cannot be safely mounted on its trucks and railed;
- The tank car tank itself is sound; however, the site conditions prevent rerailling the damaged tank car (e.g., the terrain does not permit use of cranes or other rerailling equipment);
- The tank car tank is overloaded;
- The damage to leaking valves and fittings cannot be repaired; or
- The tank car tank has been damaged to the extent that it cannot be safely railed and moved to an appropriate unloading point.

Note: The use of the vapor compressor will cause a pressure increase within the damaged tank car. It should be used only when an increase in pressure is acceptable.

Preferred Conditions

To the extent possible, the following conditions should exist, or be met, before transferring gases using a vapor compressor (these conditions are considered optimal, but may not be met in all cases due to local circumstances):

- Suitable precautions can be taken to protect people and property in the event of an accidental release during the transfer;
- Suitable transfer equipment is available (*see Required Equipment listed on page 11*);
- Personnel experienced in gas transfers are available;
- Receiving tank(s) of the proper specification with sufficient capacity are available to receive the contents of the damaged tank car (any residue in the receiving tank[s] must be compatible with the product to be transferred);
- The required liquid and/or vapor valves are accessible and operable (or the use of a hot tap is feasible);
- The tank car is in a position that will allow the transfer (e.g., excess flow check valves have not seated, or if they are seated tools are available to unseat them).

Potential Risks

The following risks may be associated with transferring gases using a vapor compressor:

- Failure of the tank or transfer equipment that could expose people, property, and the environment to the contents of the damaged tank car;
- Failure of the damaged tank car tank due to an increase in pressure from use of the vapor compressor;
- Potential contamination of the damaged car's contents that could result in an explosion and fire or the creation of a waste material.

Safety Precautions

The following safety precautions should be taken when transferring gases using a vapor compressor:

- Secure the car(s) from movement. Tighten the hand brakes and chock the wheels, if necessary.
- Place blue flags, if required.
- Limit site access to required personnel only.
- Perform transfer using only qualified personnel.
- Check to see that the transfer equipment is clean and appropriate for the product being transferred.
- Clean and wrap all pipe threads with pipe joint tape before making connections.
- Clean all hose connections before joining, replacing “O” rings and gaskets, if necessary.
- Use an emergency shut-off system (“emergency shut-off” and “back check” valves) to either automatically or manually shut down the transfer in case of an unintentional release caused by a hose break or other malfunction. *The use of the emergency shut-off system does not require personnel on the tank during the transfer.*

The emergency shut-off valve is designed to be operated from a remote location. The valve may incorporate a back flow check valve and/or fusible plug or other heat activated device that will automatically close the valve in the event of fire.

The back check valve is designed to prevent backflow in a hose. In the case of a small pressure differential, it may allow some leakage in the reverse direction.

Note: NFPA 58, Standard for Storage and Handling of Liquefied Petroleum Gas, requires emergency shut-off equipment when loading and unloading tank cars of flammable gases.

- Use the appropriate personal protective equipment.
- Monitor the site with the appropriate vapor monitoring equipment.

Safety Precautions *(continued)*

- If the product is flammable or combustible, appropriate fire fighting equipment and extinguishing agents should be available, and
- If the product is flammable or combustible, control ignition sources within 15 feet of operations:
 - Do not permit smoking on site.
 - Eliminate or shut off any electrical equipment that is not intrinsically safe, and
 - Shut off any internal-combustion engines that are not intrinsically safe.

Note: A gas transfer using a vapor compressor is considered a closed system. Although NFPA 77, Recommended Practice on Static Electricity, does not require grounding and bonding when loading and unloading tank cars through closed systems, it is considered a good practice to do so when conducting such operations in the field with flammables or combustibles.

Required Equipment

Tools and supplies

Minimum	Desired	
1	2	36" pipe wrench.
1	2	24" pipe wrench.
1	2	10" pipe wrench.
1	2	12" adjustable wrench.
1	2	Spanner or "J" wrench or brass hammer (appropriate for couplings on the hoses used).
2	2	1/4" pressure gauges with pressure range suitable for product being transferred.
1	1	Oxygen meter.
1	1	Explosimeter.
1	1	Armored thermometer with chain (<i>optional</i>).
1	1	Paint scraper.
1	1	Wire brush.
1	2	Roll of pipe joint tape.
1	1	Roll of duct tape.
1	2	Spray bottle containing commercial leak detector or a solution of dishwashing soap.
6	8	25' length of rope.
1	2	Tool bag.
	1	6' copper grounding rod.
	2	6'-8' grounding straps with clamps.

Required Equipment *(continued)*

Fittings and other gas transfer equipment

Minimum	Desired	
1	2	Liquid valve outlet assembly [See Figure 2-1]. <i>Note: An additional liquid valve outlet assembly will be required if two liquid hoses are to be placed in operation.</i>
1	2	Liquid valve inlet assembly [See Figure 2-2]. <i>Note: An additional liquid valve inlet assembly will be required if two liquid hoses are to be placed in operation.</i>
1	1	Vapor valve outlet assembly [See Figure 2-3].
1	1	Vapor valve inlet assembly [See Figure 2-4].
(6)	(6)	3"-to-2" bushings (when cars are equipped with 3-inch valves).
(1)	(1)	2" gate valve for the discharge end of the liquid hose when transferring to a cargo tank or portable tank (for wet line operation).
(1)	(1)	Adapter to cargo tank or portable tank liquid hose.
	2/4	90-degree elbows <i>(optional)</i> .
Sufficient		Lengths of liquid hose or Schedule 80 steel pipe with appropriate connectors.
Sufficient		Lengths of vapor hose or Schedule 80 steel pipe with appropriate connectors.
Sufficient		"O" rings or gaskets for liquid and vapor hoses.
		<i>Notes:</i>
		<ul style="list-style-type: none"> • <i>Hose material, "O" rings, and fittings must be compatible with the product.</i> • <i>Hoses for liquefied petroleum gas should not be interchanged with hoses used for anhydrous ammonia.</i>

Required Equipment *(continued)*

Fittings and other gas transfer equipment (continued)

Minimum	Desired	
Sufficient		1/4" nitrogen hose for purging and testing for leaks in liquid and vapor hoses (including adapters for the bleeder valves on one end and for the nitrogen regulator outlet on the other end). Hose should be able to handle pressures above that found in the tank.
Sufficient		Nitrogen hose for emergency shut-off system (minimum operating pressure of 50 psi).
1	1	Four-way fitting for the nitrogen hose for emergency shut-off system.
1	1	Control switch for emergency shut-off system.
1	2	Nitrogen regulator, 0-300 psi.
1	2	Cylinder of nitrogen.
1	2	Liquid sight glass or flow indicator (<i>optional</i>) —use only if approved in company operating procedures.
1	1	Vapor compressor (powered by an explosion proof motor and equipped with Schedule 80 steel pipe nipples with bleeder valves and adapters to vapor hose at the inlet and outlets —set up with emergency shut-off and liquid trap).

Gas Transfer Using a Vapor Compressor

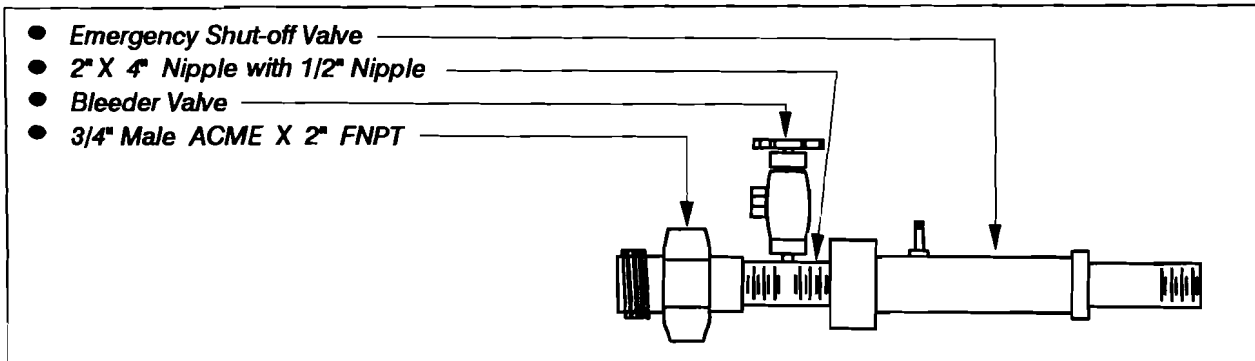

Figure 2-1: Liquid valve outlet assembly for the damaged tank car.

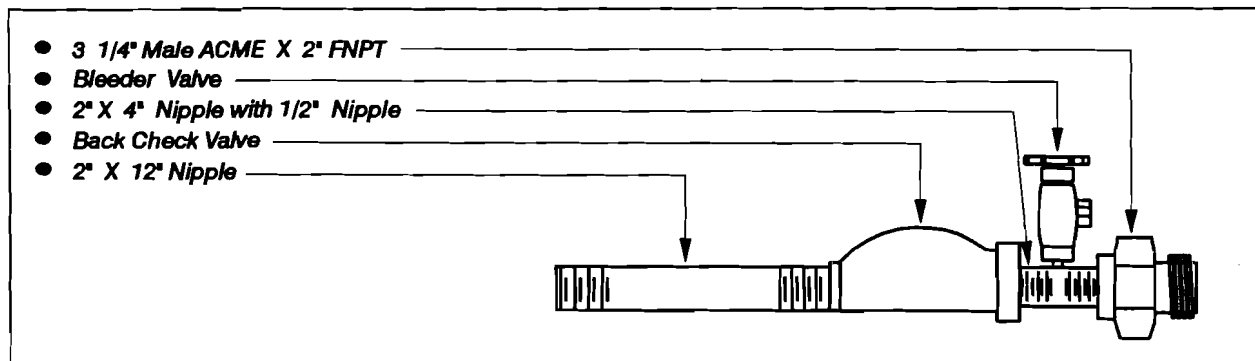

Figure 2-2: Liquid valve inlet assembly for the receiving tank.

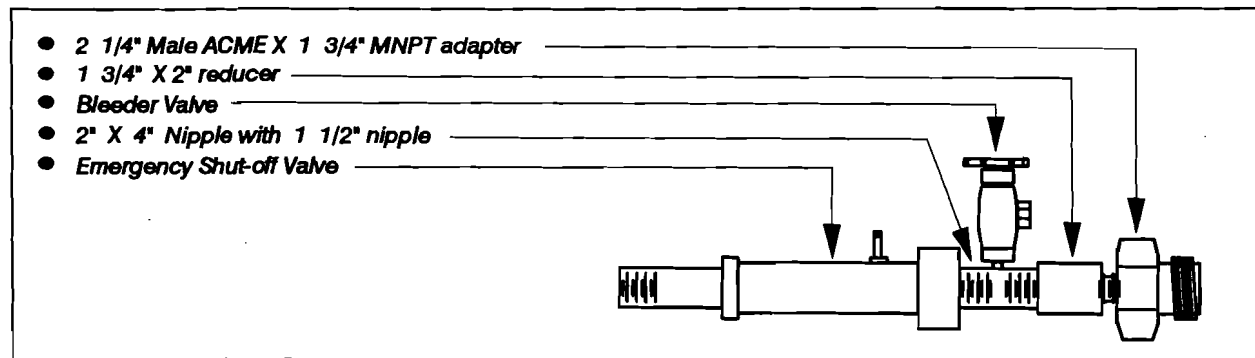

Figure 2-3: Vapor valve outlet assembly for the receiving tank.

Gas Transfer Using a Vapor Compressor

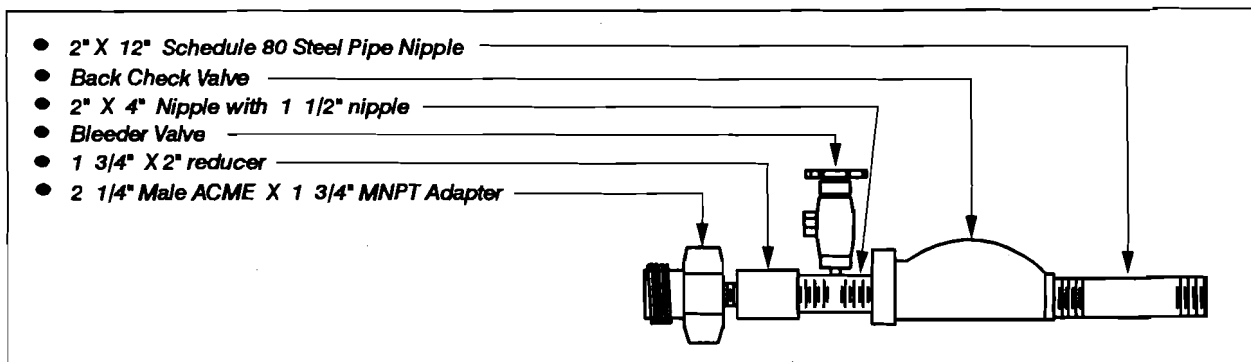

Figure 2-4: Vapor valve inlet assembly for the damaged tank car.

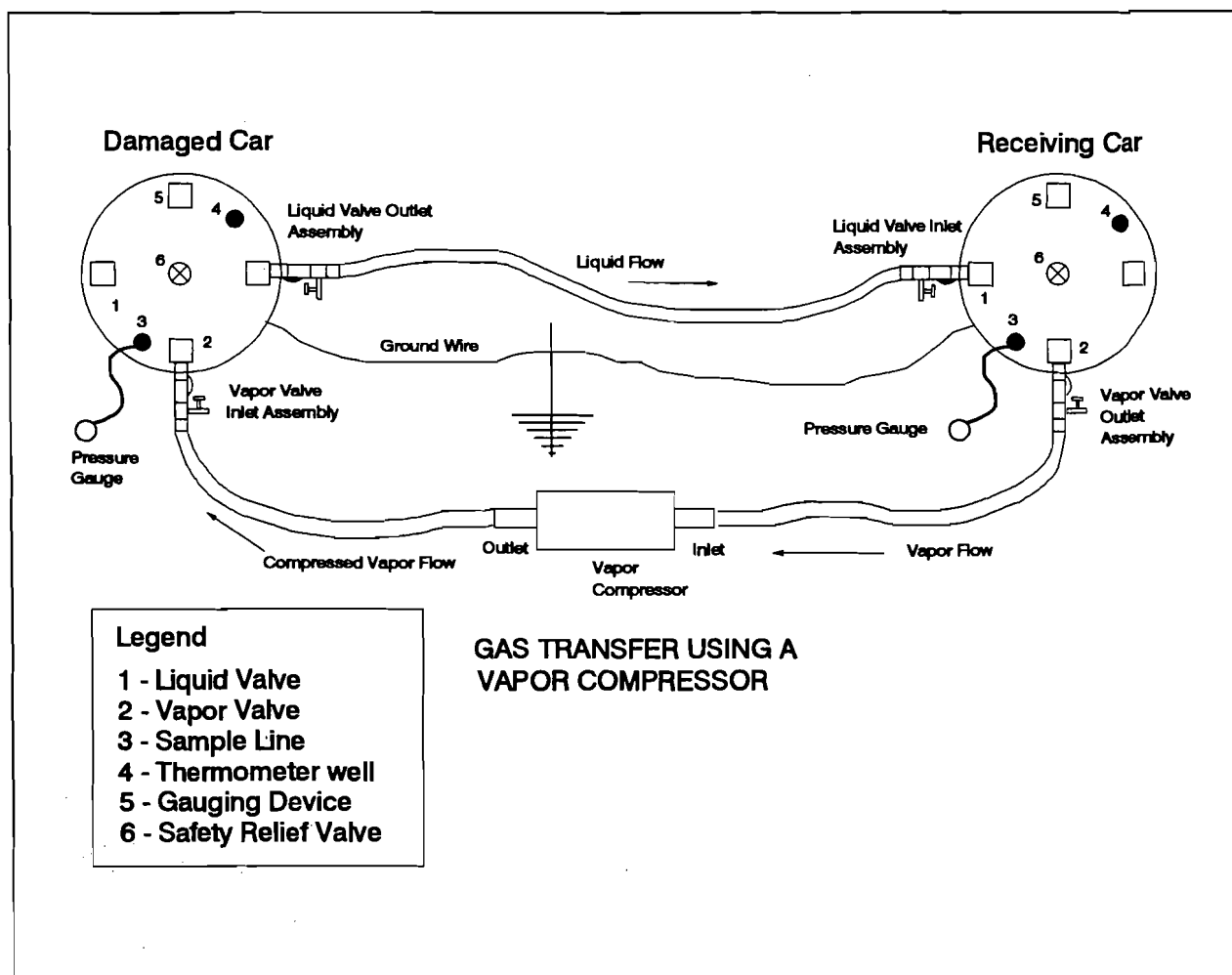

Figure 2-5: Diagram of gas transfer using a vapor compressor, tank car to tank car. Diagram for similar transfer from tank car to other-than-tank car should be prepared for the situation at hand.

Note: Grounding and bonding are recommended when transferring flammables or combustibles.

General Procedures

Plan the gas transfer operation

1. Determine the capacity of the damaged tank car and the amount of product it contains, then attach a pressure gauge to the sample line or other suitable fitting and determine the internal pressure in the damaged tank car.
2. Obtain a compatible receiving tank, preferably of sufficient capacity to receive the contents of the damaged tank car:
 - a. Check the receiving tank for damage.
 - b. If transferring tank car-to-tank car, verify that the receiving tank is of proper specification and has sufficient capacity to receive the contents of the damaged tank car; if not, obtain additional tanks.
 - c. Verify that any residue in the receiving tank is compatible with the product being transferred.
 - d. Attach a pressure gauge to the sample line or other suitable fitting and determine the internal pressure in the receiving tank.

Note: The receiving tank may contain a small amount of liquid product and vapor at a pressure equal to the vapor pressure at the temperature of the product. If a higher pressure is encountered in the receiving tank, that higher pressure may be from the nitrogen used to unload the previous contents.
3. Prepare a checklist of all equipment required to perform the transfer.
4. Prepare a plan for set-up, implementation, and shut-down of the transfer operation:
 - a. Diagram the location and orientation of the cars involved.
 - b. Diagram the location and orientation of equipment, gauges, hoses, and connections to be used in the transfer.
 - c. Prepare a checklist of the procedures for set-up, implementation, and shut-down of the transfer process.
5. Prepare a site safety plan.
6. Obtain the required transfer equipment.

Set up the gas transfer operation

1. Hold a safety briefing and discuss items such as:
 - Person in charge.
 - Properties of products.
 - Signals for emergency shut-down.
 - Evacuation routes.
 - Etc.
2. Position the receiving tank and transfer equipment.
3. If the pressure in the receiving tank must be reduced to attain the desired pressure differential and the vapors cannot be put into the damaged tank car, responder should flare, vent, or transfer the vapors to another tank.
4. Connect fittings.
 - a. On the damaged tank car:
 - Clean the male pipe threads and wrap them with pipe joint tape.
Note: When necessary, clean the female threads with a pipe tap.
 - Attach the vapor valve inlet assembly (with check valve) to a vapor valve.
 - Attach the liquid valve outlet assembly (with emergency shut-off valve) to a liquid valve.
 - Position all valve assemblies with the bleeder valve outlet/inlet in a horizontal position and tighten.
 - *Optional:* If used, attach a 90-degree elbow to the liquid valve outlet assembly and tighten with the open end pointed toward the side of the car where the hoses will be attached.
 - b. On the receiving tank:
 - Clean the male pipe threads and wrap them with pipe joint tape.
Note: When necessary, clean the female threads with a pipe tap.
 - Attach the liquid valve inlet assembly (with check valve) to a liquid valve.
 - Attach the vapor valve outlet assembly (with emergency shut-off valve) to a vapor valve.

Set up the gas transfer operation (continued)

- Position all valve assemblies with the bleeder valve outlet/inlet in a horizontal position and tighten.
 - *Optional:* If used, attach a 90-degree elbow to the liquid valve inlet assembly and tighten with the open end pointed toward the side of the car where the hoses will be attached.
5. Attach required hoses or piping:
- Note: Pipe can be substituted for hose if the damaged tank is stationary on the ground. Because of the possibility of movement, hoses should be used if tanks are on their trucks.*
- Caution: Clean all hoses and piping as necessary to remove any contaminants that may be present.*
- a. Check for “O” rings or gaskets in all hoses and replace if missing or damaged.
 - b. Attach the liquid and vapor hoses to both tanks:
 - Connect liquid hoses directly from the liquid valve outlet assembly on the damaged tank car to the liquid valve inlet assembly on the receiving tank.
 - Connect vapor hoses from the vapor valve outlet assembly on the receiving tank into the vapor compressor inlet, then from the vapor compressor outlet to the vapor valve inlet assembly on the damaged tank car.
 - c. Secure the hoses with ropes to reduce strain on the valve assemblies and hose couplings.
 - d. Use spanner or “J” wrench or brass hammer to tighten Acme thread couplings.
6. Purge liquid and vapor hoses and fittings and test for leaks:
- a. Place the nitrogen cylinder adjacent to the tank car being unloaded and attach the regulator to the nitrogen cylinder.
 - b. Set nitrogen regulator to 50 psi.
 - c. Close all bleeder valves on both cars.
 - d. Purge the vapor hose and fittings and test for leaks (*purge only if the product is reactive with air or moisture*):
 - Attach one end of a nitrogen hose to the vapor hose bleeder valve at the receiving tank and attach the other end of the hose to the regulator on the nitrogen cylinder.
 - Open the valve on the nitrogen cylinder.
 - Open the vapor hose bleeder valve at the receiving tank.

Set up the gas transfer operation (continued)

- Open the vapor hose bleeder valve at the damaged tank car and discharge to atmosphere.
 - Test the discharge from the vapor hose bleeder valve at the damaged tank car with an oxygen meter. *When the oxygen level falls dramatically, the vapor hose is full of nitrogen.*
 - When the vapor hose is full of nitrogen, (1) close the vapor hose bleeder valve at the damaged tank car, (2) close the vapor hose bleeder valve at the receiving tank, (3) check the hose for leaks. Correct leaks as necessary.
 - Close the valve on the nitrogen cylinder.
- e. Purge the liquid hose and fittings and test for leaks (*purge only if the product is reactive with air or moisture*):
- Attach a nitrogen hose between the liquid hose bleeder valve on the damaged tank car and the regulator on the nitrogen cylinder.
 - Open the valve on the nitrogen cylinder.
 - Open the liquid hose bleeder valve at the damaged tank car.
 - Open the liquid hose bleeder valve at the receiving tank and discharge to atmosphere.
 - Test the discharge from the liquid hose bleeder valve at the receiving tank with an oxygen meter. *When oxygen level falls dramatically, the liquid hose is full of nitrogen.*
 - When the liquid hose is full of nitrogen, (1) close the liquid hose bleeder valve at the receiving tank, (2) close the liquid hose bleeder valve at the damaged tank car, (3) check the liquid hose for leaks. Correct leaks as necessary.
 - Close the valve on the nitrogen cylinder.
7. Set up the emergency shut-off system, if used, by connecting hoses between all components of the emergency shut-off system.

Implement the gas transfer operation

1. Determine the internal pressure in both the damaged tank car and the receiving tank again.
2. Activate the emergency shut-off system.
3. Adjust the pressure differential, if necessary, by using the vapor compressor to raise the pressure in the damaged tank car 5-10 psi above the pressure in the receiving tank.
4. Start the liquid flow:
 - a. Slowly open the liquid valve on the receiving tank fully.
 - b. Slowly open the liquid valve on the damaged tank car one-quarter of the way, wait 30 seconds, then open the valve all the way.

Note: Throughout the transfer operation, all liquid valves should be opened fully for maximum flow. Many compressed-gas cars are equipped with handle-operated ball valves that are operated by rotating the handle 180° from the horizontal closed position to the vertical open position. Others have wheel-operated plug-type valves that require several revolutions to open the valve. The statement, "open the valve one-quarter of the way," refers to both types of valves.
5. Start the vapor flow:
 - a. Slowly open the vapor valve on the receiving tank fully.
 - b. Slowly open the vapor valve on the damaged tank car fully.
6. Start the vapor compressor and run continuously to maintain the required pressure differential.
7. Verify that product is flowing from the damaged tank car by:
 - a. Looking for liquid flow in the sight glass,
 - b. Observing the flow indicator, or
 - c. Gauging the car using the gauging device (amount indicates liquid level dropping).

General Procedures *(continued)*

Implement the gas transfer operation (continued)

8. Periodically check for indications that the product flow has ceased:
 - a. Gauge tank to determine when the car is nearly full.
 - b. Check the sight glass periodically for bubbles. Bubbles indicate the last of the liquid is being withdrawn.
 - c. Observe the flow indicator.
 - d. Watch for buckling of the liquid hose.
9. Monitor the liquid level in the receiving tank using the gauging device to verify that the tank is not being overfilled.

Shut down the gas transfer operation

1. When product ceases to flow, shut down the transfer operation:
 - a. Turn vapor compressor off.
 - b. Allow pressure to equalize.
 - c. Close the vapor valve on the receiving tank.
 - d. Close the vapor valve on the damaged tank car.
 - e. Close the liquid valve on the damaged tank car.
 - f. Close the liquid valve on the receiving tank.

2. Purge hoses and/or piping:
 - a. Purge vapor hose:
 - Adjust the regulator on nitrogen cylinder 15 psi higher than the pressure in the damaged tank car.
 - Open the valve on the nitrogen cylinder.
 - Open the vapor hose bleeder valve at the receiving tank.
 - Open the vapor valve on the damaged tank car.
 - After 20 seconds, partially open the vapor hose bleeder valve at the damaged tank.

Note: If the product is flammable, test the discharge with an Explosimeter. When the Explosimeter does not pick up explosive concentrations in the discharge from the bleeder valve, the vapor hose is full of nitrogen.
 - b. When the vapor hose is full of nitrogen:
 - Close the vapor valve on the damaged tank car.
 - Close the vapor hose bleeder valve at the damaged tank car.
 - Close the vapor hose bleeder valve at the receiving tank.
 - Close the valve on the nitrogen cylinder near the receiving tank.
 - Open the bleeder valves to vent the nitrogen from the hose.

Shut down the gas transfer operation (continued)

- c. Purge liquid hose:
 - Adjust the regulator on nitrogen cylinder 15 psi higher than the pressure in the receiving tank.
 - Open the valve on nitrogen cylinder.
 - Open the liquid hose bleeder valve at the damaged tank car.
 - Wait 30 seconds, then open the liquid valve on the receiving tank, wait 30 seconds and close the liquid valve on the receiving tank.
 - Repeat the process four times to remove as much liquid from the liquid hose as possible.
 - After repeating the process four times:
 - Close the liquid valve on the receiving tank.
 - Close the liquid hose bleeder valve at the damaged tank car.
 - Close the valve on the nitrogen cylinder near the damaged tank car.
 - Open the bleeder valves to vent the nitrogen from the hose.
- Caution:** Some product may remain in the liquid hose after purging, therefore use caution when disassembling and lowering hoses to the ground.

3. Disassemble and clean the transfer equipment.
4. Secure car (apply plugs in vapor, liquid, and sample lines and gauging device valves and tighten with a suitable tool).

This page left blank intentionally

Section 3

Gas Transfer Using a Liquid Pump

Overview

This transfer method uses a liquid pump to move the contents of a damaged or overloaded tank car into a receiving tank (e.g., a tank car, cargo tank, or portable tank). Pressure is equalized between the damaged or overloaded tank car and the receiving tank. The product in the damaged or overloaded tank car is then pumped into the receiving tank.

The gas transfer using a liquid pump may be used when:

- The tank car tank itself is sound; however, due to bolster or other mechanical damage the car cannot be safely mounted on its trucks and railed;
- The tank car tank itself is sound; however, the site conditions prevent rerailing the damaged tank car (e.g., the terrain does not permit use of cranes or other rerailing equipment);
- The tank car tank is overloaded;
- The damage to leaking valves and fittings cannot be repaired; or
- The tank car tank has been damaged to the extent that it cannot be safely railed and moved to an appropriate unloading point.

Note: The liquid pump does not increase the pressure within the damaged tank car, unless another means of creating a positive pressure differential is used (vapor compressor or inert gas).

Preferred Conditions

To the extent possible, the following conditions should exist, or be met, when transferring gases using a liquid pump (these conditions are considered optimal, but may not be met in all cases due to local circumstances):

- Suitable precautions can be taken to protect people and property in the event of an accidental release during the transfer;
- Suitable transfer equipment is available (*see Required Equipment listed on page 29*);
- Personnel experienced in gas transfers are available; and
- Receiving tank(s) of the proper specification with sufficient capacity are available to receive the contents of the damaged tank car (any residue in the receiving tank[s] must be compatible with the product to be transferred);
- The required liquid and/or vapor valves are accessible and operable (or the use of a hot tap is feasible).
- The tank car is in a position that will allow the transfer (e.g., excess flow check valves have not seated, or, if seated, tools are available to unseat them).

Potential Risks

The following risks may be associated with transferring gases using a liquid pump:

- Failure of the tank or transfer equipment could expose people, property, and the environment to the contents of the damaged tank car.
- Potential contamination of the damaged car's contents could result in an explosion and fire or the creation of a waste material.

Safety Precautions

The following safety precautions should be taken when transferring a gas using a liquid pump:

- Secure the car(s) from movement. Tighten the hand brakes and chock the wheels, if necessary.
- Place blue flags, if required.
- Limit site access to required personnel only.
- Perform transfer using only qualified personnel.
- Check to see that the transfer equipment is clean and appropriate for the product being transferred.
- Clean and wrap all pipe threads with pipe joint tape before making connections.
- Clean all hose connections before joining, replacing “O” rings and gaskets, if necessary.
- Use an emergency shut-off system (“emergency shut-off” and “back check” valves) to either automatically or manually shut down the transfer in case of an unintentional release caused by a hose break or other malfunction. *The use of the emergency shut-off system does not require personnel on the tank during the transfer.*

The emergency shut-off valve is designed to be operated from a remote location. The valve may incorporate a back flow check valve and/or fusible plug or other heat activated device that will automatically close the valve in the event of fire.

The back check valve is designed to prevent backflow in a hose. In the case of a small pressure differential, it may allow some leakage in the reverse direction.

Note: NFPA 58, Standard for Storage and Handling of Liquefied Petroleum Gas, requires emergency shut-off equipment when loading and unloading tank cars.

- Use the appropriate personal protective equipment.
- Monitor the site with the appropriate vapor monitoring equipment.

Safety Precautions *(continued)*

- If the product is flammable or combustible, appropriate fire fighting equipment and extinguishing agents should be available.
- If product is flammable or combustible, control ignition sources within 15 feet of operations:
 - Do not permit smoking on site.
 - Eliminate or shut off any electrical equipment that is not intrinsically safe.
 - Shut off any internal-combustion engines that are not intrinsically safe.

Note: A gas transfer using a liquid pump is considered a closed system. Although NFPA 77, Recommended Practice on Static Electricity, does not require grounding and bonding when loading and unloading tank cars through closed systems, it is considered a good practice to do so when conducting such operations in the field with flammables or combustibles.

Required Equipment

Tools and supplies

Minimum	Desired	
1	2	36" pipe wrench.
1	2	24" pipe wrench.
1	2	10" pipe wrench.
1	2	12" adjustable wrench.
1	2	Spanner or "J" wrench or brass hammer (appropriate for couplings on the hoses used).
2	2	1/4" pressure gauges with pressure range suitable for product being transferred.
1	1	Oxygen meter.
1	1	Explosimeter.
1	1	Armored thermometer with chain (<i>optional</i>).
1	1	Paint scraper.
1	1	Wire brush.
1	2	Roll of pipe joint tape.
1	1	Roll of duct tape.
1	2	Spray bottle containing commercial leak detector or a solution of dishwashing soap.
6	8	25' length of rope.
1	2	Tool bag.
	1	6' copper grounding rod.
	2	6'-8' grounding straps with clamps.

Required Equipment *(continued)*

Fittings and other gas transfer equipment

Minimum	Desired	
1	1	Liquid valve outlet assembly [See Figure 3-1].
1	1	Liquid valve inlet assembly [See Figure 3-2].
1	1	Vapor valve outlet assembly [See Figure 3-3].
1	1	Vapor valve inlet assembly [See Figure 3-4].
(4)	(4)	3"-to-2" bushings (when cars are equipped with 3" valves).
(1)	(1)	2" gate valve for the discharge end of the liquid hose when transferring to a cargo tank or portable tank (for wet line operation).
(1)	(1)	Adapter to cargo tank or portable tank liquid hose.
2	4	90-degree elbows <i>(optional)</i> .
Sufficient		Lengths of liquid hose or Schedule 80 steel pipe with appropriate connectors.
Sufficient		Lengths of vapor hose or Schedule 80 steel pipe with appropriate connectors.
Sufficient		"O" rings or gaskets for liquid and vapor hoses.
		Notes:
		<ul style="list-style-type: none"> • <i>Hose material, "O" rings, and fittings must be compatible with the product.</i> • <i>Hoses for liquefied petroleum gas should not be interchanged with hoses used for anhydrous ammonia.</i>
Sufficient		1/4" nitrogen hose for purging and testing for leaks in liquid and vapor hoses (including adapters for the bleeder valves on one end and for the nitrogen regulator outlet on the other end) Hose should be able to handle pressures above that found in the tank.

Required Equipment *(continued)*

Fittings and other gas transfer equipment (continued)

Minimum Sufficient	Desired	
		Nitrogen hose for emergency shut-off system (minimum operating pressure of 50 psi).
1	1	Four-way fitting for the nitrogen hose for emergency shut-off system.
1	1	Control switch for emergency shut-off system.
1	2	Nitrogen regulator, 0-300 psi.
1	2	Cylinder of nitrogen.
1	2	Liquid sight glass or flow indicator <i>(optional)</i> —use only if approved in company operating procedures.
1	1	Liquid pump (powered by an explosion proof motor and equipped with Schedule 80 steel pipe nipples with bleeder valves and adapters to vapor hose at the inlet and outlets).

Gas Transfer Using a Liquid Pump

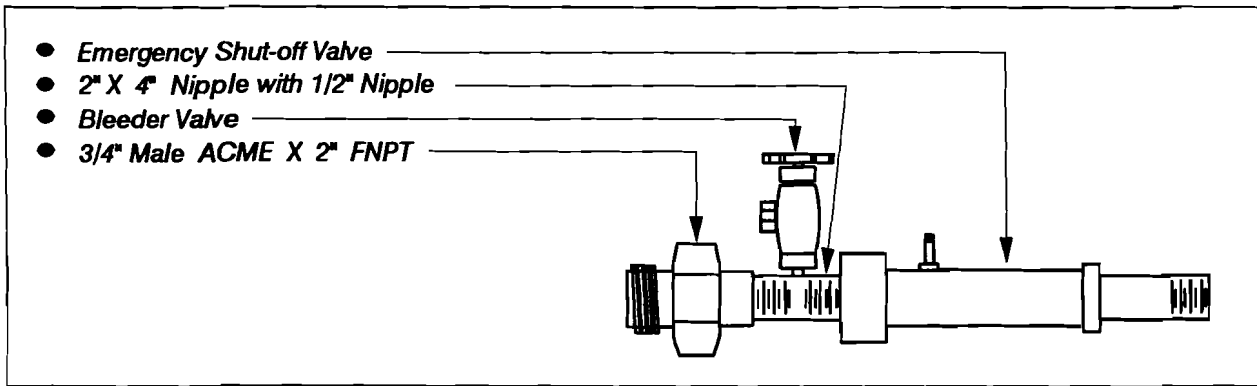

Figure 3-1: Liquid valve outlet assembly for the damaged tank car.

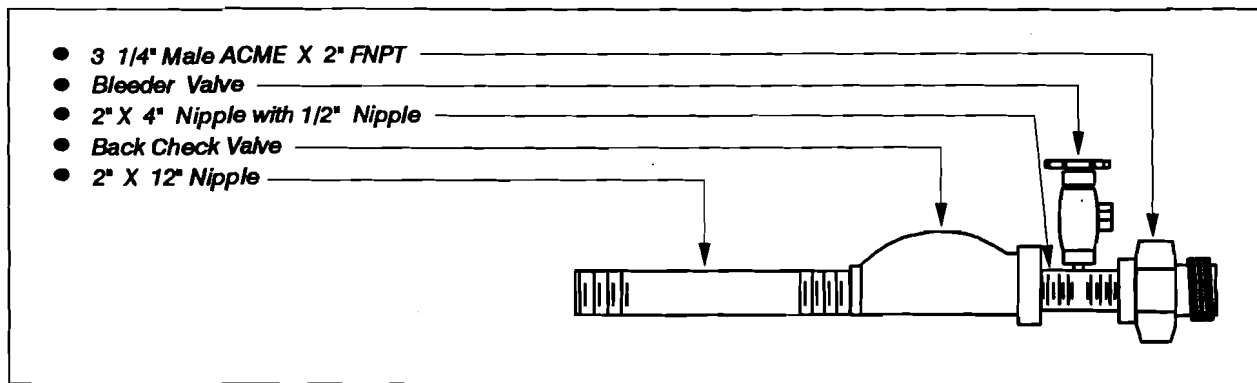

Figure 3-2: Liquid valve inlet assembly for the receiving tank.

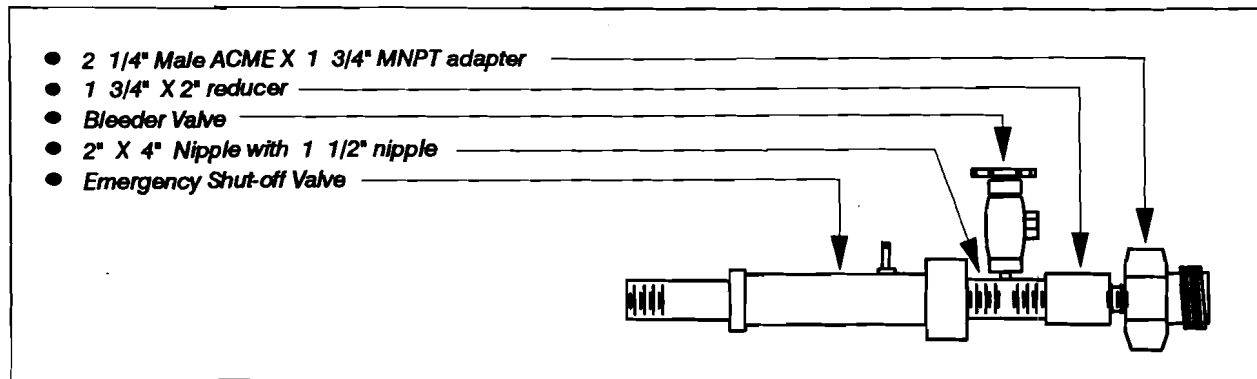

Figure 3-3: Vapor valve outlet assembly for the receiving tank.

Gas Transfer Using a Liquid Pump

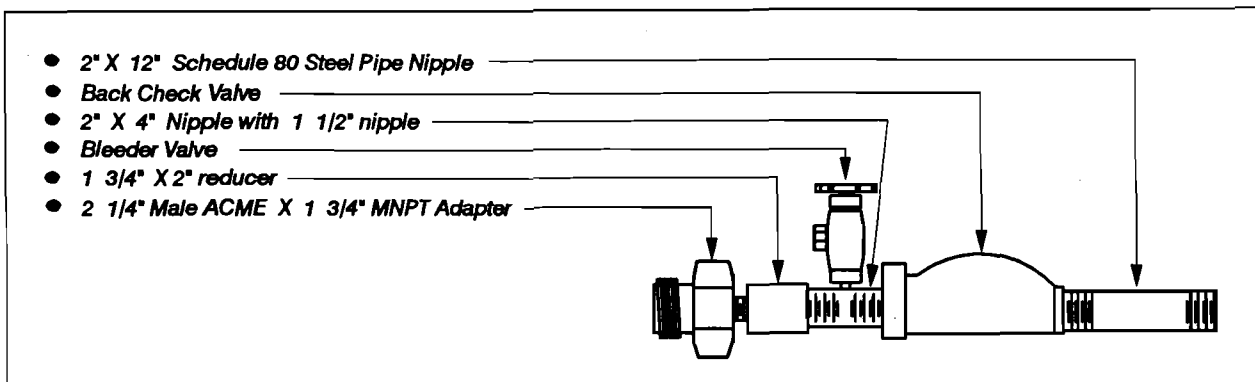

Figure 3-4: Vapor valve inlet assembly for the damaged tank car.

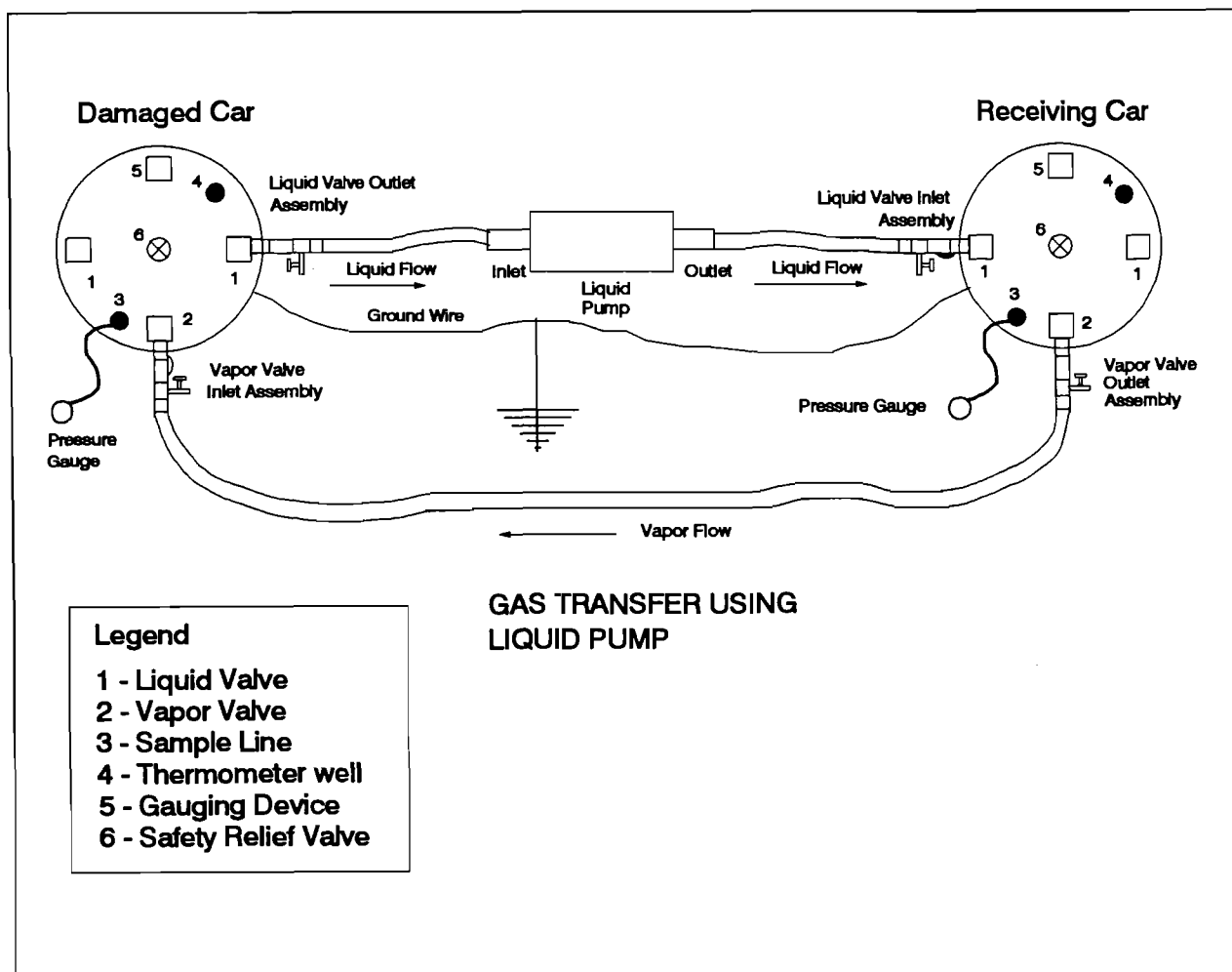

Figure 3-5: Diagram of gas transfer using a liquid pump tank car to tank car. Diagram for similar transfer from tank car to other-than-tank car should be prepared for the situation at hand.

Note: Grounding and bonding are recommended when transferring flammables or combustibles.

General Procedures

Plan the gas transfer operation

1. Determine the capacity of the damaged tank car and the amount of product it contains, then attach a pressure gauge to the sample line or other suitable fitting and determine the internal pressure in the damaged tank car.
2. Obtain a compatible receiving tank, preferably of sufficient capacity to receive the contents of the damaged tank car:
 - a. Check the receiving tank for damage.
 - b. If transferring tank car-to-tank car, verify that the receiving tank is of the proper specifications and has sufficient capacity to receive the contents of the damaged tank car; if not, obtain additional tanks.
 - c. Verify that any residue in the receiving tank is compatible with the product being transferred.
 - d. Attach a pressure gauge to the sample line or other suitable fitting and determine the internal pressure in the receiving tank.

Note: The receiving tank may contain a small amount of liquid product and vapor at a pressure equal to the vapor pressure at the temperature of the product. If a higher pressure is encountered in the receiving tank, that higher pressure may be from the nitrogen used to unload the previous contents.

3. Prepare a checklist of all equipment required to perform the transfer.
4. Prepare a plan for set-up, implementation, and shut-down of the transfer operation:
 - a. Diagram the location and orientation of the cars involved.
 - b. Diagram the location and orientation of equipment, gauges, hoses, and connections to be used in the transfer.
 - c. Prepare a checklist of the procedures for set-up, implementation, and shut-down of the transfer process.
5. Prepare a site safety plan.
6. Obtain the required transfer equipment.

Set up the gas transfer operation

1. Hold a safety briefing and discuss items such as:
 - Person in charge.
 - Properties of products.
 - Signals for emergency shut-down.
 - Evacuation routes.
 - Etc.
2. Position the receiving tank and transfer equipment.
3. If the pressure in the receiving tank must be reduced to attain the desired pressure differential and the vapors cannot be put into the damaged tank car, responder should flare, vent, or transfer the vapors to another tank.
4. Connect fittings:
 - a. On the damaged tank car:
 - Clean the male pipe threads and wrap them with pipe joint tape.
Note: When necessary, clean the female threads with a pipe tap.
 - Attach the vapor valve inlet assembly (with check valve) to a vapor valve.
 - Attach the liquid valve outlet assembly (with emergency shut-off valve) to a liquid valve.
 - Position all valve assemblies with the bleeder valve outlet/inlet in a horizontal position and tighten.
 - *Optional:* If used, attach a 90-degree elbow to the liquid valve outlet assembly and tighten with the open end pointed toward the side of the car where the hoses will be attached.
 - b. On the receiving tank:
 - Clean the male pipe threads and wrap them with pipe joint tape.
Note: When necessary, clean the female threads with a pipe tap.
 - Attach the liquid valve inlet assembly (with check valve) to a liquid valve.
 - Attach the vapor valve outlet assembly (with emergency shut-off valve) to a vapor valve.

Set up the gas transfer operation (continued)

- Position all valve assemblies with the bleeder valve outlet/inlet in a horizontal position and tighten.
 - *Optional:* If used, attach a 90-degree elbow to the liquid valve inlet assembly and tighten with the open end pointed toward the side of the car where the hoses will be attached.
5. Attach required hoses or piping:
- Note: Pipe can be substituted for hose if the damaged tank is stationary on the ground. Because of the possibility of movement, hoses should be used if tanks are on their trucks.*
- Caution: Clean all hoses and piping as necessary to remove any contaminants that may be present.*
- a. Check for "O" rings or gaskets in all hoses and replace if missing or damaged.
 - b. Attach the liquid and vapor hoses to both tanks:
 - Connect liquid hoses directly from the liquid valve outlet assembly on the damaged tank car to the liquid pump inlet, then from the liquid pump outlet to the liquid valve inlet assembly on the receiving tank.
 - Connect vapor hoses from the vapor valve outlet assembly on the receiving tank to the vapor valve inlet assembly on the damaged tank car.
 - c. Secure the hoses with ropes to reduce strain on the valve assemblies and hose couplings.
 - d. Use spanner or "J" wrench or brass hammer to tighten Acme thread couplings.
6. Purge liquid and vapor hoses and fittings and test for leaks:
- a. Place the nitrogen cylinder adjacent to the tank car being unloaded and attach the regulator to the nitrogen cylinder.
 - b. Set nitrogen regulator to 50 psi.
 - c. Close all bleeder valves on both cars.
 - d. Purge the vapor hose and fittings and test for leaks (*purge only if the product is reactive with air or moisture*):
 - Attach one end of a nitrogen hose to the vapor hose bleeder valve at the receiving tank and attach the other end of the hose to the regulator on the nitrogen cylinder.
 - Open the valve on the nitrogen cylinder.
 - Open the vapor hose bleeder valve at the receiving tank.

Set up the gas transfer operation (continued)

- Open the vapor hose bleeder valve at the damaged tank car and discharge to atmosphere.
 - Test the discharge from the vapor hose bleeder valve at the damaged tank car with an oxygen meter. *When the oxygen level falls dramatically, the vapor hose is full of nitrogen.*
 - When the vapor hose is full of nitrogen, (1) close the vapor hose bleeder valve at the damaged tank car, (2) close the vapor hose bleeder valve at the receiving tank, (3) check the hose for leaks. Correct leaks as necessary.
 - Close the valve on the nitrogen cylinder.
- e. Purge the liquid hose and fittings and test for leaks (*purge only if the product is reactive with air or moisture*):
- Attach a nitrogen hose between the liquid hose bleeder valve on the damaged tank car and the regulator on the nitrogen cylinder.
 - Open the valve on the nitrogen cylinder.
 - Open the liquid hose bleeder valve at the damaged tank car.
 - Open the liquid hose bleeder valve at the receiving tank and discharge to atmosphere.
 - Test the discharge from the liquid hose bleeder valve at the receiving tank with an oxygen meter. *When oxygen level falls dramatically, the liquid hose is full of nitrogen.*
 - When the liquid hose is full of nitrogen, (1) close the liquid hose bleeder valve at the receiving tank, (2) close the liquid hose bleeder valve at the damaged tank car, (3) check the liquid hose for leaks. Correct leaks as necessary.
 - Close the valve on the nitrogen cylinder.
7. Set up the emergency shut-off system, if used, by connecting hoses between all components of the emergency shut-off system.

Implement the gas transfer operation

1. Determine the internal pressure in both the damaged tank car and the receiving tank again.
2. Activate the emergency shut-off system.
3. Adjust the pressure differential, if necessary:
 - a. Slowly open the liquid valve on the receiving tank fully.
 - b. Slowly open the vapor valve on the damaged tank car fully.
4. Start the flow of liquid from the damaged tank car:
 - a. Fully open the liquid valve on the receiving tank.
 - b. Open the liquid valve on the damaged tank car one-quarter of the way, wait 30 seconds, open the valve half way, wait 30 seconds, then open the valve all the way.

Note: Throughout the transfer operation, all liquid valves should be opened fully to attain maximum flow.
5. Start the liquid pump.
6. Verify that product is flowing from the damaged tank car by:
 - a. Looking for liquid flow in the sight glass.
 - b. Observing the flow indicator, or
 - c. Gauging the car using the gauging device (amount indicates liquid level dropping).
7. Periodically check for indications that the liquid flow has ceased:
 - a. Check the sight glass periodically for bubbles. Bubbles indicate the last of the liquid is being withdrawn.
 - b. Observe the flow indicator.
 - c. Watch for buckling of the liquid hose.
 - d. Listen for differences in pump sound.
8. Monitor the liquid level in the receiving tank using the gauging device to verify that the tank is not being overfilled.

Shut down the gas transfer operation

1. When liquid ceases to flow, shut down the transfer operation:
 - a. Turn liquid pump off.
 - b. Allow pressure to equalize.
 - c. Close the vapor valve on the receiving tank.
 - d. Close the vapor valve on the damaged tank car.
 - e. Close the liquid valve on the damaged tank car.
 - f. Close the liquid valve on the receiving tank.

2. Purge hoses and/or piping:

- a. Purge vapor hose.
 - Adjust the regulator on nitrogen cylinder 15 psi higher than the pressure in the damaged tank car.
 - Open the valve on the nitrogen cylinder.
 - Open the vapor hose bleeder valve at the receiving tank.
 - Open the vapor valve on the damaged tank car.
 - After 20 seconds, partially open the vapor hose bleeder valve at the damaged tank.

Note: If the product is flammable, test the discharge with an Explosimeter. When the Explosimeter does not pick up explosive concentrations in the discharge from the bleeder valve, the vapor hose is full of nitrogen.

When the vapor hose is full of nitrogen:

- Close the vapor valve on the damaged tank car.
- Close the vapor hose bleeder valve at the damaged tank car.
- Close the vapor hose bleeder valve at the receiving tank.
- Close the valve on the nitrogen cylinder near the receiving tank.
- Open the bleeder valves to vent the nitrogen from the hose.

Shut down the gas transfer operation (continued)

b. Purge liquid hose:

- Adjust the regulator on nitrogen cylinder 15 psi higher than the pressure in the receiving tank.
- Open the valve on nitrogen cylinder.
- Open the liquid hose bleeder valve at the damaged tank car.
- Wait 30 seconds, then open the liquid valve on the receiving tank, wait 30 seconds and close the liquid valve on the receiving tank.
- Repeat the process four times to remove as much liquid from the liquid hose as possible.
- After repeating the process four times:
 - Close the liquid valve on the receiving tank.
 - Close the liquid hose bleeder valve at the damaged tank car.
 - Close the valve on the nitrogen cylinder near the damaged tank car.
 - Open the bleeder valves to vent the nitrogen from the hose.

Caution: Some liquid may remain in the liquid hose after purging, therefore use caution when disassembling and lowering hoses to the ground.

3. Disassemble and clean the transfer equipment.
4. Secure cars (apply plugs in vapor, liquid, sample line, and gauging device valves and tighten with a suitable tool).

Section 4

Gas Transfer Using a Liquid Pump and a Vapor Compressor

Overview

This transfer method uses a liquid pump and a vapor compressor to move the contents of a damaged or overloaded tank car into a recovery tank (e.g., a tank car, cargo tank, or portable tank). The vapor compressor is used to accelerate the rate of transfer by withdrawing vapors from the receiving tank, compressing them, and forcing them into the damaged tank car. The higher pressure in the damaged tank car helps keep the pump primed.

This gas transfer using a liquid pump and a vapor compressor may be used when:

- The tank car tank itself is sound; however, due to bolster or other mechanical damage, the car cannot be safely mounted on its trucks and railed;
- The tank car tank itself is sound; however, the site conditions prevent rerailing the damaged tank car (e.g., the terrain does not permit use of cranes or other rerailing equipment);
- The tank car tank is overloaded;
- The damage to leaking valves and fittings cannot be repaired; or
- The tank car tank has been damaged to the extent that it cannot be safely railed and moved to an appropriate unloading point.

Note: The use of the vapor compressor will cause a pressure increase within the damaged tank car. It should be used only when an increase in pressure is acceptable.

Preferred Conditions

To the extent possible, the following conditions should exist, or be met, before transferring gases using a liquid pump and a vapor compressor (these conditions are considered optimal, but may not be met in all cases due to local circumstances):

- A delayed rupture is not likely;
- The tank is not exposed to fire;
- The tank car is in a position that will allow the transfer (e.g., excess flow check valves have not seated, or, if seated, tools are available to unseat them);
- The required liquid and/or vapor valves are accessible and operable (or the use of a hot tap is feasible);
- Receiving tank(s) of the proper specification with sufficient capacity are available to receive the contents of the damaged tank car (any residue in the receiving tank[s] must be compatible with the product to be transferred);
- Suitable transfer equipment is available (*see Required Equipment list on page 45*).
- Personnel experienced in gas transfers are available; and
- Suitable precautions can be taken to protect people and property in the event of an accidental release during the transfer.

Potential Risks

The following risks may be associated with transferring gases using a liquid pump and a vapor compressor:

- Failure of the tank or transfer equipment that could expose people, property, and the environment to the contents of the damaged tank car;
- Failure of the damaged tank car tank due to an increase in pressure from use of the vapor compressor;
- Potential contamination of the damaged car's contents that could result in an explosion and fire or the creation of a waste material.

Safety Precautions

The following safety precautions should be taken when transferring gases using a vapor compressor:

- Secure the car(s) from movement. Tighten the hand brakes and chock the wheels, if necessary.
- Place blue flags, if required.
- Limit site access to required personnel only.
- Perform transfer using only qualified personnel.
- Check to see that the transfer equipment is clean and appropriate for the product being transferred.
- Clean and wrap all pipe threads with pipe joint tape before making connections.
- Clean all hose connections before joining, replacing “O” rings and gaskets, if necessary.
- Use an emergency shut-off system (“emergency shut-off” and “back check” valves) to either automatically or manually shut down the transfer in case of an unintentional release caused by a hose break or other malfunction. *The use of the emergency shut-off system does not require personnel on the tank during the transfer.*

The emergency shut-off valve is designed to be operated from a remote location. The valve may incorporate a back flow check valve and/or fusible plug or other heat activated device that will automatically close the valve in the event of fire.

The back check valve is designed to prevent backflow in a hose. In the case of a small pressure differential, it may allow some leakage in the reverse direction.

Note: NFPA 58, Standard for Storage and Handling of Liquefied Petroleum Gas, requires emergency shut-off equipment when loading and unloading tank cars of flammable gases.

- Use the appropriate personal protective equipment.
- Monitor the site with the appropriate vapor monitoring equipment.

Safety Precautions *(continued)*

- If the product is flammable or combustible, appropriate fire fighting equipment and extinguishing agents should be available, and
- If the product is flammable or combustible, control ignition sources within 15 feet of operations:
 - Do not permit smoking on site.
 - Eliminate or shut off any electrical equipment that is not intrinsically safe.
 - Shut off any internal-combustion engines that are not intrinsically safe.

Note: A gas transfer using a vapor compressor is considered a closed system. Although NFPA 77, Recommended Practice on Static Electricity, does not require grounding and bonding when loading and unloading tank cars through closed systems, it is considered a good practice to do so when conducting such operations in the field with flammables or combustibles.

Required Equipment

Tools and supplies

Minimum	Desired	
1	2	36" pipe wrench.
1	2	24" pipe wrench.
1	2	10" pipe wrench.
1	2	12" adjustable wrench.
1	2	Spanner or "J" wrench or brass hammer (appropriate for couplings on the hoses used).
2	2	1/4" pressure gauges with pressure range suitable for product being transferred.
1	1	Oxygen meter.
1	1	Explosimeter.
1	1	Armored thermometer with chain (<i>optional</i>).
1	1	Paint scraper.
1	1	Wire brush.
1	2	Rolls of pipe joint tape.
1	1	Roll of duct tape.
1	2	Spray bottle containing commercial leak detector or a solution of dishwashing soap.
6	8	25' length of rope.
	1	6' copper grounding rod.
	2	6'-8' grounding straps with clamps.

Required Equipment *(continued)*

Fittings and other gas transfer equipment

Minimum	Desired	
1	2	Liquid valve outlet assembly [See Figure 4-1].
1	1	Liquid valve inlet assembly [See Figure 4-2].
1	1	Vapor valve outlet assembly [See Figure 4-3].
1	1	Vapor valve inlet assembly [See Figure 4-4].
(4)	(4)	3" to 2" bushing (when cars are equipped with 3" valves).
(1)	(1)	2" gate valve for the discharge end of the liquid hose when transferring to a cargo tank or portable tank (for wet line operation).
(1)	(1)	Adapter to cargo tank or portable tank liquid hose.
2	4	90-degree elbows <i>(optional)</i> .
Sufficient		Lengths of liquid hose or Schedule 80 steel pipe with appropriate connectors.
Sufficient		Lengths of vapor hose or Schedule 80 steel pipe with appropriate connectors.
Sufficient		"O" rings or gaskets for liquid and vapor hoses.
		Notes:
		<ul style="list-style-type: none"> • <i>Hose material, "O" rings, and fittings must be compatible with the product.</i> • <i>Hoses for liquefied petroleum gas should not be interchanged with hoses used for anhydrous ammonia.</i>

Required Equipment *(continued)*

Fittings and other gas transfer equipment (continued)

Minimum	Desired	
Sufficient		1/4" nitrogen hose for purging and testing for leaks in liquid and vapor hoses (including adapters for the bleeder valves on one end and for the nitrogen regulator outlet on the other end). Hose should be able to handle pressures above that found in the tanks.
Sufficient		Nitrogen hose for emergency shut-off system (minimum operating pressure of 50 psi).
1	1	Four-way fitting for the nitrogen hose for emergency shut-off system.
1	1	Control switch for emergency shut-off system.
1	2	Nitrogen regulator, 0-300 psi.
1	2	Cylinder of nitrogen.
1	2	Liquid sight glass or flow indicator <i>(optional)</i> —use only if approved in company operating procedures.
1	1	Liquid pump (powered by an explosion proof motor and equipped with Schedule 80 steel pipe nipples with bleeder valves and adapters to liquid hose at the inlet and outlets).
1	1	Vapor compressor (powered by an explosion proof motor and equipped with Schedule 80 steel pipe nipples with bleeder valves and adapters to vapor hose at the inlet and outlets —set up with emergency shut-off and liquid trap).

Gas Transfer Using a Liquid Pump and a Vapor Compressor

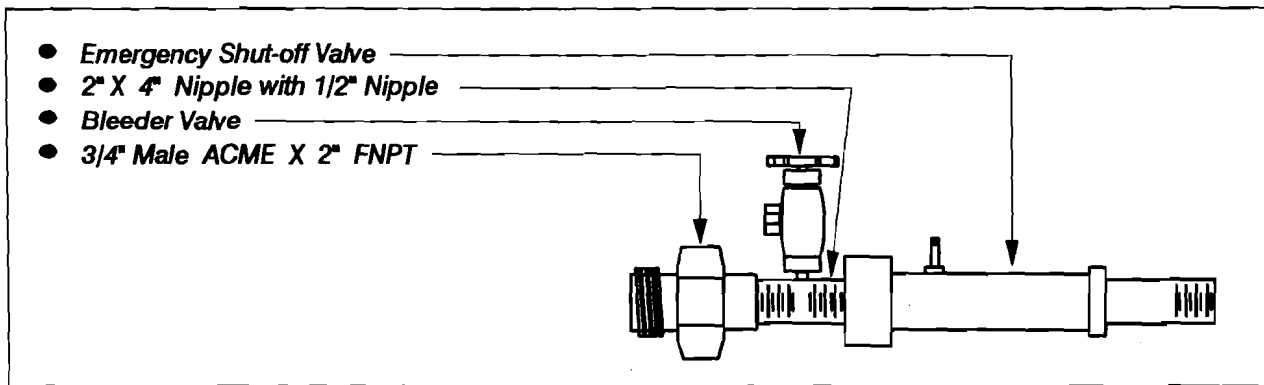

Figure 4-1: Liquid valve outlet assembly for the damaged tank car.

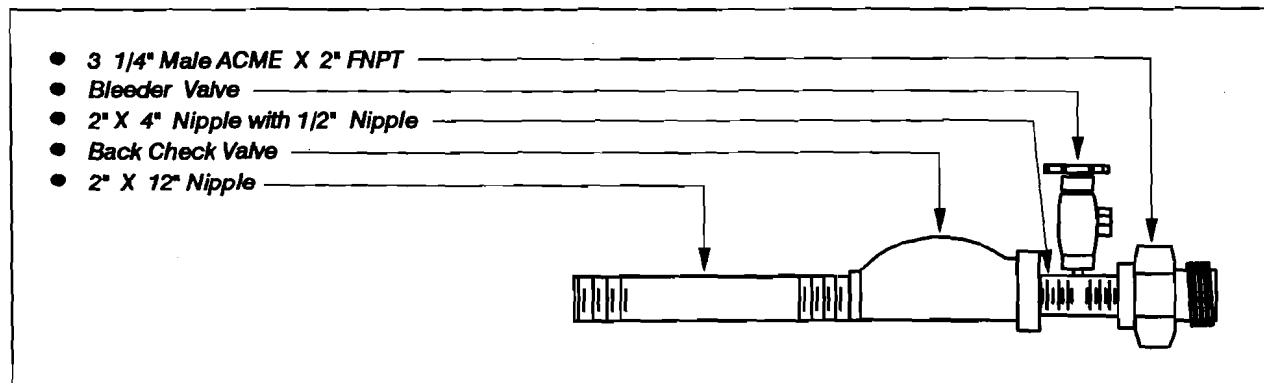

Figure 4-2: Liquid valve inlet assembly for the receiving tank.

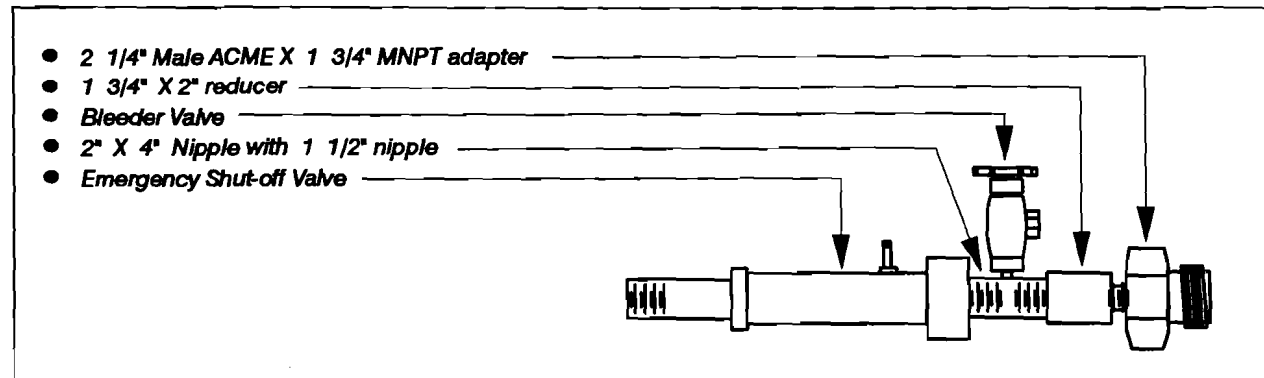

Figure 4-3: Vapor valve outlet assembly for the receiving tank.

Gas Transfer Using a Liquid Pump and a Vapor Compressor

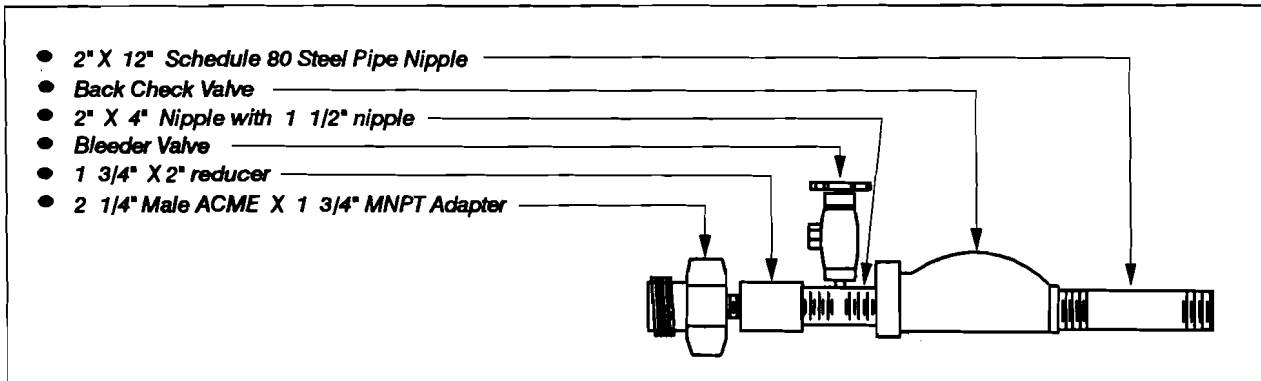

Figure 4-4: Vapor valve inlet assembly for the damaged tank car.

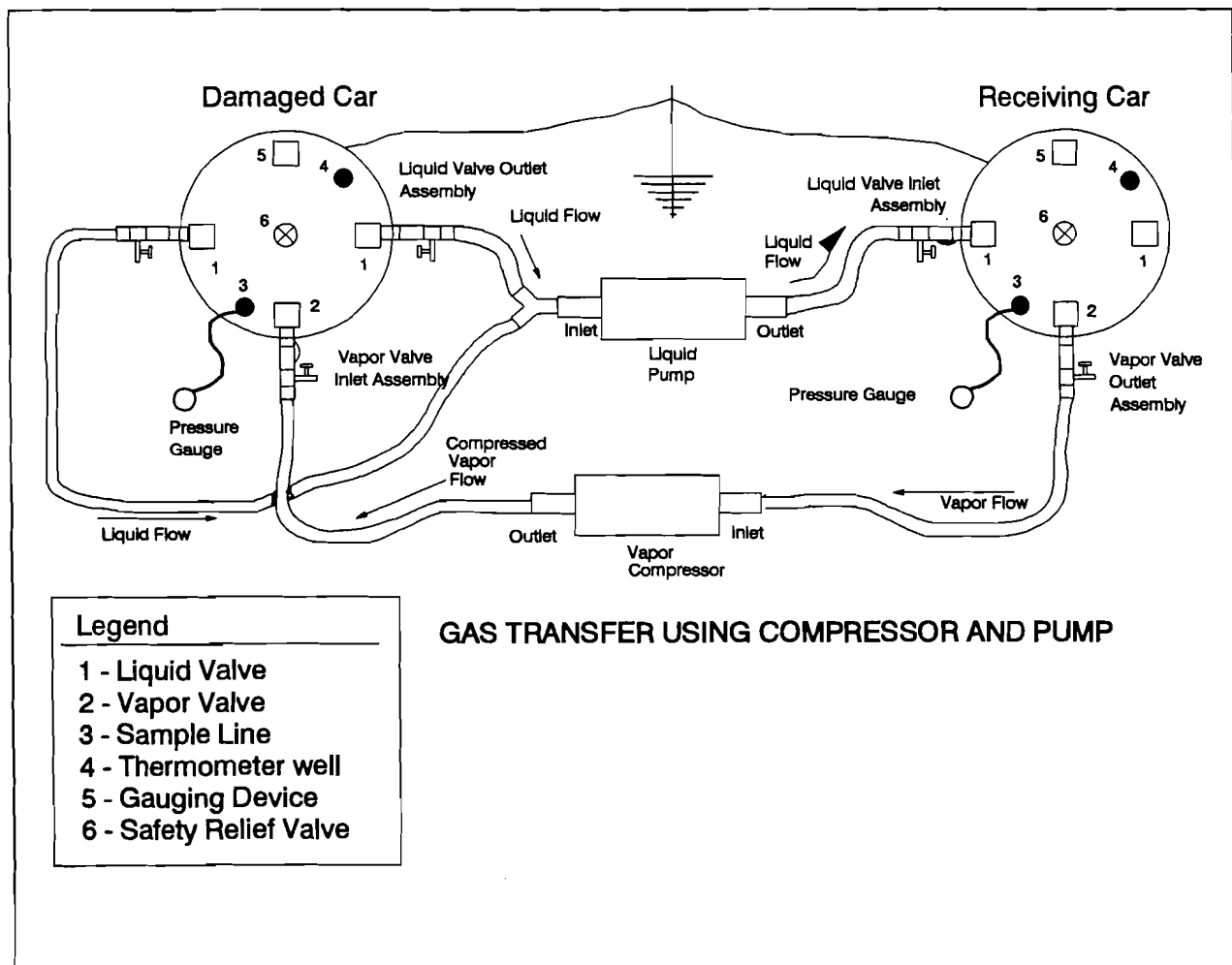

Figure 4-5: Diagram of gas transfer using a liquid pump and a vapor compressor, tank car to tank car. Diagram for similar transfer from tank car to other-than-tank car should be prepared for the situation at hand.

Note: Grounding and bonding are recommended when transferring flammables or combustibles.

General Procedures

Plan the gas transfer operation

1. Determine the capacity of the damaged tank car and the amount of product it contains, then attach a pressure gauge to the sample line or other suitable fitting and determine the internal pressure in the damaged tank car.
2. Obtain a compatible receiving tank, preferably of sufficient capacity to receive the contents of the damaged tank car:
 - a. Check the receiving tank for damage.
 - b. If transferring tank car-to-tank car, verify that the receiving tank is of the proper specifications and has sufficient capacity to receive the contents of the damaged tank car; if not, obtain additional tanks.
 - c. Verify that any residue in the receiving tank is compatible with the product being transferred.
 - d. Attach a pressure gauge to the sample line or other suitable fitting and determine the internal pressure in the receiving tank.

Note: The receiving tank may contain a small amount of liquid product and vapor at a pressure equal to the vapor pressure at the temperature of the product. If a higher pressure is encountered in the receiving tank, that higher pressure may be from the nitrogen used to unload the previous contents.
3. Prepare a checklist of all equipment required to perform the transfer.
4. Prepare a plan for set-up, implementation, and shut-down of the transfer operation:
 - a. Diagram the location and orientation of the cars involved.
 - b. Diagram the location and orientation of equipment, gauges, hoses, and connections to be used in the transfer.
 - c. Prepare a checklist of the procedures for set-up, implementation, and shut-down of the transfer process.
5. Prepare a site safety plan.
6. Obtain the required transfer equipment.

Set up the gas transfer operation

1. Hold a safety briefing and discuss items such as:
 - Person in charge.
 - Properties of products.
 - Signals for emergency shut-down.
 - Evacuation routes.
 - Etc.
2. Position the receiving tank and transfer equipment.
3. If the pressure in the receiving tank must be reduced to attain the appropriate pressure differential and the vapors cannot be put into the damaged tank car, responder should flare, vent, or transfer the vapors to another tank.
4. Connect fittings:
 - a. On the damaged tank car:
 - Clean the male pipe threads and wrap them with pipe joint tape.
Note: When necessary, clean the female threads with a pipe tap.
 - Attach the vapor valve inlet assembly (with check valve) to a vapor valve.
 - Attach the liquid valve outlet assembly (with emergency shut-off valve) to a liquid valve.
 - Position all valve assemblies with the bleeder valve outlet/inlet in a horizontal position and tighten.
 - *Optional:* If used, attach a 90-degree elbow to the liquid valve outlet assembly and tighten with the open end pointed toward the side of the car where the hoses will be attached.
 - b. On the receiving tank:
 - Clean the male pipe threads and wrap them with pipe joint tape.
Note: When necessary, clean the female threads with a pipe tap.
 - Attach the liquid valve inlet assembly (with check valve) to a liquid valve.
 - Attach the vapor valve outlet assembly (with emergency shut-off valve) to a vapor valve.

Set up the gas transfer operation (continued)

- Position all valve assemblies with the bleeder valve outlet/inlet in a horizontal position and tighten.
 - *Optional:* If used, attach a 90-degree elbow to the liquid valve inlet assembly and tighten with the open end pointed toward the side of the car where the hoses will be attached.
5. Attach required hoses and/or piping:
- Note: Pipe can be substituted for hose if the tanks are stationary on the ground. Hoses should be used if tanks are on their trucks.*
- Caution: Clean all hoses and piping as necessary to remove any contaminants that may be present.*
- a. Check for “O” rings or gaskets in all hoses and replace if missing or damaged.
 - b. Attach the liquid and vapor hoses to both tanks:
 - Connect liquid hoses directly from the liquid valve outlet assembly on the damaged tank car to the liquid pump inlet, then from the liquid pump outlet to a liquid valve inlet assembly on the receiving tank.
 - Connect vapor hoses from the vapor valve outlet assembly on the receiving tank into the vapor compressor inlet, then from the vapor compressor outlet to the vapor valve inlet assembly on the damaged tank car.
 - c. Secure the hoses with ropes to reduce strain on the valve assemblies and hose couplings.
 - d. Use spanner or “J” wrench or brass hammer to tighten Acme thread couplings.
6. Purge liquid and vapor hoses and fittings and test for leaks.
- a. Place the nitrogen cylinder adjacent to the tank car being unloaded and attach the regulator to the nitrogen cylinder.
 - b. Set nitrogen regulator to 50 psi.
 - c. Close all bleeder valves on both cars.
 - d. Purge the vapor hose and fittings and test for leaks (*purge only if the product is reactive with air or moisture*):
 - Attach one end of a nitrogen hose to the vapor hose bleeder valve at the receiving tank and attach the other end of the hose to the regulator on the nitrogen cylinder.
 - Open the valve on the nitrogen cylinder.

Set up the gas transfer operation (continued)

- Open the vapor hose bleeder valve at the receiving tank.
 - Open the vapor hose bleeder valve at the damaged tank car (discharge to atmosphere).
 - Test the discharge from the vapor hose bleeder valve at the damaged tank car with an oxygen meter. *When the oxygen level falls dramatically, the vapor hose is full of nitrogen.*
 - When the vapor hose is full of nitrogen, (1) close the vapor hose bleeder valve at the damaged tank car, (2) close the vapor hose bleeder valve at the receiving tank, (3) check the hose for leaks. Correct leaks as necessary.
 - Close the valve on the nitrogen cylinder.
- e. Purge the liquid hose and fittings and test for leaks (*purge only if the product is reactive with air or moisture*):
- Attach one end of a nitrogen hose to the liquid hose bleeder valve at the damaged tank car and attach the other end of the hose to the regulator on the nitrogen cylinder.
 - Open the valve on the nitrogen cylinder.
 - Open the liquid hose bleeder valve at the damaged tank car.
 - Open the liquid hose bleeder valve at the receiving tank (discharge to atmosphere).
 - Test the discharge from the liquid hose bleeder valve at the receiving tank with an oxygen meter. *When oxygen level falls dramatically, the liquid hose is full of nitrogen.*
 - When the liquid hose is full of nitrogen, (1) close the liquid hose bleeder valve at the receiving tank, (2) close the liquid hose bleeder valve at the damaged tank car, (3) check the liquid hose for leaks. Correct leaks as necessary.
 - Close the valve on the nitrogen cylinder.
7. Set up the emergency shut-off system, if used, by connecting hoses between all components of the emergency shut-off system.

Implement the gas transfer operation

1. Determine the internal pressure in both the damaged tank car and the receiving tank again.
2. Activate the emergency shut-off system.
3. Adjust the pressure differential, if necessary. (Use the vapor compressor to adjust the pressure in the receiving tank 5-10 psi less than the pressure in the damaged tank car.)
4. Start the flow of product from damaged tank car:
 - a. Slowly open the liquid valve on the receiving tank fully.
 - b. Slowly open the liquid valve on the damaged tank car one-quarter of the way, wait 30 seconds, open the valve half way, wait 30 seconds, then open the valve all the way.

Note: Throughout the transfer operation, all liquid valves should be opened fully to attain maximum flow.
 - c. Start the liquid pump.
5. Start the vapor flow:
 - a. Slowly open the vapor valve on the receiving tank fully.
 - b. Slowly open the vapor valve on the damaged tank car fully.
 - c. Start the vapor compressor and run as necessary to maintain the required pressure differential.
6. Verify that liquid is flowing from the damaged tank car by:
 - a. Looking for liquid flow in the sight glass.
 - b. Observing the flow indicator, or
 - c. Gauging the car using the gauging device (amount indicates liquid level dropping).
7. Monitor the liquid level in the receiving tank using the gauging device to verify that the tank is not being overfilled.
8. Periodically check for indications that the liquid flow has ceased:
 - a. Check the sight glass periodically for bubbles. Bubbles indicate the last of the liquid is being withdrawn.
 - b. Observe the flow indicator.
 - c. Watch for buckling of the liquid hose.
 - d. Listen for difference in pump sound.

Shut down the gas transfer operation

1. When liquid ceases to flow, shut down the transfer operation:
 - a. Turn vapor compressor off.
 - b. Allow pressure to equalize.
 - c. Close the vapor valve on the receiving tank.
 - d. Close the vapor valve on the damaged tank car.
 - e. Turn liquid pump off.
 - f. Close the liquid valve on the damaged tank car.
 - g. Close the liquid valve on the receiving tank.
2. Purge hoses and/or piping:
 - a. Purge vapor hose:
 - Adjust the regulator on nitrogen cylinder 15 psi higher than the pressure in the damaged tank car.
 - Open the valve on the nitrogen cylinder.
 - Open the vapor hose bleeder valve at the receiving tank.
 - Open the vapor valve on the damaged tank car.
 - After 20 seconds, partially open the vapor hose bleeder valve at the damaged tank.

Note: If the product is flammable, test the discharge with an Explosimeter. When the Explosimeter does not pick up explosive concentrations in the discharge from the bleeder valve, the vapor hose is full of nitrogen.

When the vapor hose is full of nitrogen:

 - Close the vapor valve on the damaged tank car.
 - Close the vapor hose bleeder valve at the damaged tank car.
 - Close the vapor hose bleeder valve at the receiving tank.
 - Close the valve on the nitrogen cylinder near the receiving tank.
 - Open the bleeder valves to vent the nitrogen from the hose.

Shut down the gas transfer operation (continued)

b. Purge liquid hose:

- Adjust the regulator on nitrogen cylinder 15 psi higher than the pressure in the receiving tank.
- Open the valve on nitrogen cylinder.
- Open the liquid hose bleeder valve at the damaged tank car.
- Wait 30 seconds, then open the liquid valve on the receiving tank, wait 30 seconds and close the liquid valve on the receiving tank.
- Repeat the process four times to remove as much liquid from the liquid hose as possible.
- After repeating the process four times:
 - Close the liquid valve on the receiving tank.
 - Close the liquid hose bleeder valve at the damaged tank car.
 - Close the valve on the nitrogen cylinder near the damaged tank car.
 - Open the bleeder valves to vent the nitrogen from the hose.

Caution: Some liquid may remain in the liquid hose after purging, therefore use caution when disassembling and lowering hoses to the ground.

3. Disassemble and clean the transfer equipment.
4. Secure cars (apply plugs in vapor, liquid, sample line, and gauging device valves and tighten with a suitable tool).

Section 5

Gas Transfer Using an Inert Gas

Overview

This transfer method uses an inert gas compatible with the product (e.g., nitrogen or carbon dioxide) to move the contents of a damaged or overloaded tank car into a receiving tank (e.g., a tank car, cargo tank, or portable tank). The inert gas creates a positive pressure differential in the damaged tank car that pushes the liquid into the receiving tank. Vapor from the receiving tank may have to be vented to the atmosphere or scrubbed.

This gas transfer using an inert gas may be used when:

- The tank car tank itself is sound; however, due to bolster or other mechanical damage, the car cannot be safely mounted on its trucks and railed;
- The tank car tank itself is sound; however, the site conditions prevent rerailing the damaged tank car (e.g., the terrain does not permit use of cranes or other rerailing equipment);
- The tank car tank is overloaded;
- The damage to leaking valves and fittings cannot be repaired; or
- The tank car tank has been damaged to the extent that it cannot be safely railed and moved to an appropriate unloading point.

Note: Because of the use of the inert gas, this method will result in a pressure increase within the damaged tank car. It should be used only when an increase in pressure is acceptable.

Preferred Conditions

To the extent possible, the following conditions should exist, or be met, before transferring gases using an inert gas (these conditions are considered optimal, but may not be met in all cases due to local circumstances):

- Suitable precautions can be taken to protect people and property in the event of an accidental release during the transfer;
- Suitable transfer equipment is available (*see Required Equipment listed on page 61*);
- Personnel experienced in gas transfers are available;
- Receiving tank(s) of the proper specification with sufficient capacity are available to receive the contents of the damaged tank car (any residue in the receiving tank[s] must be compatible with the product to be transferred);
- The required liquid and/or vapor valves are accessible and operable (or the use of a hot tap is feasible);
- The tank car is in a position that will allow the transfer (e.g., excess flow check valves have not seated, or if they are seated tools are available to unseat them).

Potential Risks

The following risks may be associated with transferring gases using an inert gas:

- Failure of the tank or transfer equipment that could expose people, property, and the environment to the contents of the damaged tank car;
- Failure of the damaged tank car tank due to an increase in pressure from use of the inert gas;
- Potential contamination of the damaged car's contents that could result in an explosion and fire or the creation of a waste material.

Safety Precautions

The following safety precautions should be taken when transferring gases using an inert gas:

- Secure the car(s) from movement. Tighten the hand brakes and chock the wheels, if necessary.
- Place blue flags, if required.
- Limit site access to required personnel only.
- Perform transfer using only qualified personnel.
- Check to see that the transfer equipment is clean and appropriate for the product being transferred.
- Clean and wrap all pipe threads with pipe joint tape before making connections.
- Clean all hose connections before joining, replacing “O” rings and gaskets, if necessary.
- Use an emergency shut-off system (“emergency shut-off” and “back check” valves) to either automatically or manually shut down the transfer in case of an unintentional release caused by a hose break or other malfunction. *The use of the emergency shut-off system does not require personnel on the tank during the transfer.*

The emergency shut-off valve is designed to be operated from a remote location. The valve may incorporate a back flow check valve and/or fusible plug or other heat activated device that will automatically close the valve in the event of fire.

The back check valve is designed to prevent backflow in a hose. In the case of a small pressure differential, it may allow some leakage in the reverse direction.

Note: NFPA 58, Standard for Storage and Handling of Liquefied Petroleum Gas, requires emergency shut-off equipment when loading and unloading tank cars of flammable gases.

- Use the appropriate personal protective equipment.
- Monitor the site with the appropriate vapor monitoring equipment.

Safety Precautions *(continued)*

- If the product is flammable or combustible, appropriate fire fighting equipment and extinguishing agents should be available, and
- If the product is flammable or combustible, control ignition sources within 15 feet of operations:
 - Do not permit smoking on site.
 - Eliminate or shut off any electrical equipment that is not intrinsically safe.
 - Shut off any internal-combustion engines that are not intrinsically safe.

Note: A gas transfer using a vapor compressor is considered a closed system. Although NFPA 77, Recommended Practice on Static Electricity, does not require grounding and bonding when loading and unloading tank cars through closed systems, it is considered a good practice to do so when conducting such operations in the field with flammables or combustibles.

Required Equipment

Tools and supplies

Minimum	Desired	
1	2	36" pipe wrench.
1	2	24" pipe wrench.
1	2	10" pipe wrench.
1	2	12" adjustable wrench.
1	2	Spanner or "J" wrench or brass hammer (appropriate for couplings on the hoses used).
2	2	1/4" pressure gauges with pressure range suitable for product being transferred.
1	1	Oxygen meter.
1	1	Explosimeter.
1	1	Armored thermometer with chain (<i>optional</i>).
1	1	Paint scraper.
1	1	Wire brush.
1	2	Rolls of pipe joint tape.
1	1	Roll of duct tape.
1	2	Spray bottle containing commercial leak detector or a solution of dishwashing soap.
6	8	25' length of rope.
1	2	Tool bag.
	1	6' copper grounding rod.
	2	6'-8' grounding straps with clamps.

Required Equipment *(continued)*

Fittings and other gas transfer equipment

Minimum	Desired	
1	1	Liquid valve outlet assembly [See Figure 5-1].
1	1	Liquid valve inlet assembly [See Figure 5-2].
1	1	Vapor valve outlet assembly [See Figure 5-3].
1	1	Vapor valve inlet assembly [See Figure 5-4].
(4)	(4)	3"-to-2" bushings (when cars are equipped with 3" valves).
(1)	(1)	2" gate valve for the discharge end of the liquid hose when transferring to a cargo tank or portable tank (for wet line operation).
(1)	(1)	Adapter to cargo tank or portable tank liquid hose.
2	4	90-degree elbows <i>(optional)</i> .
Sufficient		Lengths of liquid hose or Schedule 80 steel pipe with appropriate connectors.
Sufficient		Lengths of vapor hose or Schedule 80 steel pipe with appropriate connectors.

Required Equipment *(continued)*

Fittings and other gas transfer equipment (continued)

	Sufficient		“O” rings or gaskets for liquid and vapor hoses.
			<i>Notes:</i>
			<ul style="list-style-type: none"> • <i>Hose material, “O” rings, and fittings must be compatible with the product.</i> • <i>Hoses for liquefied petroleum gas should not be interchanged with hoses used for anhydrous ammonia.</i>
	Sufficient		1/4” nitrogen hose for purging and testing for leaks in liquid and vapor hoses (including adapters for the bleeder valves on one end and for the nitrogen regulator outlet on the other end). Hose should be able to handle pressures above that found in the tank.
	Sufficient		Nitrogen hose for emergency shut-off system (minimum operating pressure of 50 psi).
1		1	Four-way fitting for the nitrogen hose for emergency shut-off system.
1		1	Control switch for emergency shut-off system.
1		2	Nitrogen regulator, 0-300 psi.
1		2	Cylinder of nitrogen.
1		2	Liquid sight glass or flow indicator <i>(optional)</i> —use only if approved in company operating procedures.
1		1	Sufficient quantity of inert gas for transfer (cylinders, tube trailers, etc.).

Gas Transfer Using an Inert Gas

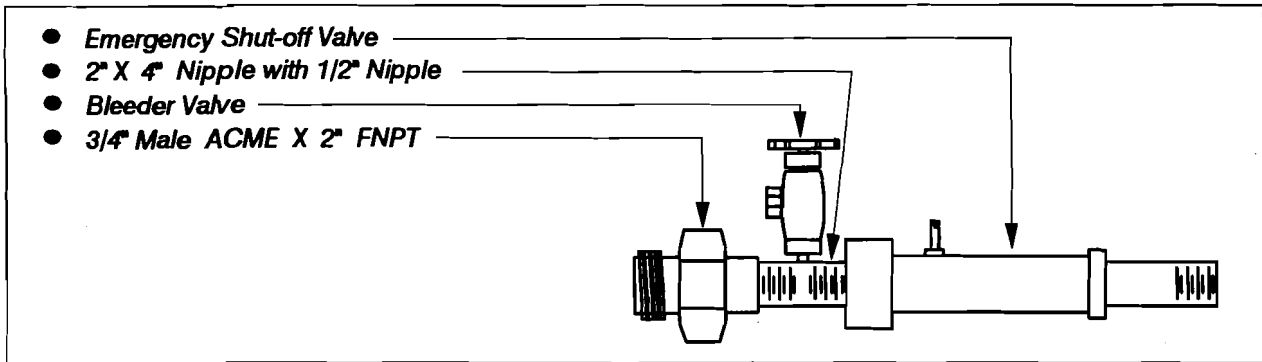

Figure 5-1: Liquid valve outlet assembly for the damaged tank car.

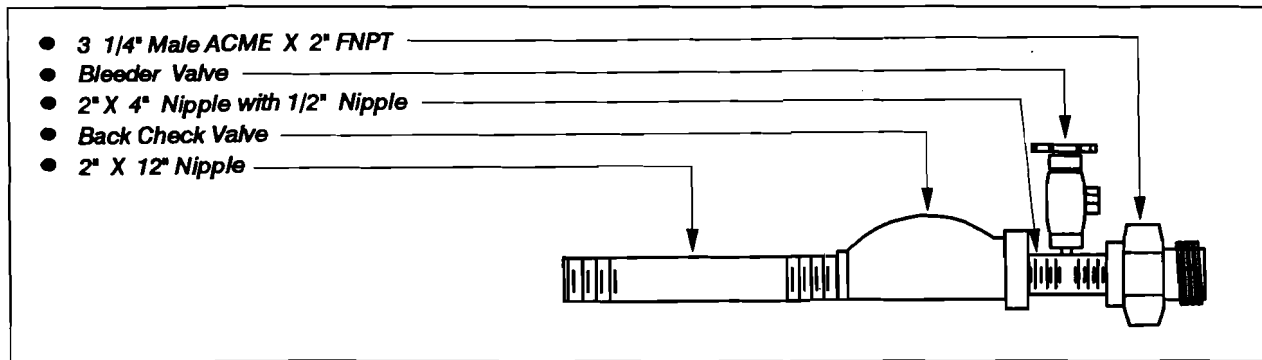

Figure 5-2: Liquid valve inlet assembly for the receiving tank.

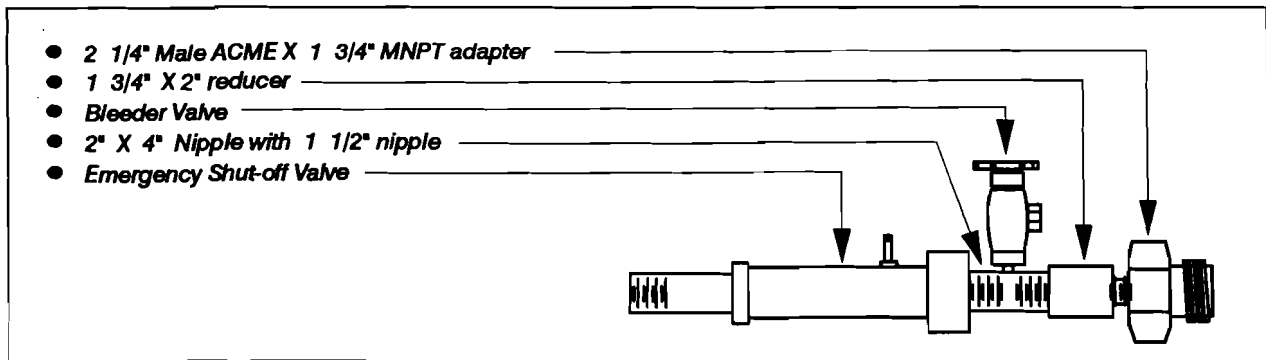

Figure 5-3: Vapor valve outlet assembly for the receiving tank.

Gas Transfer Using an Inert Gas

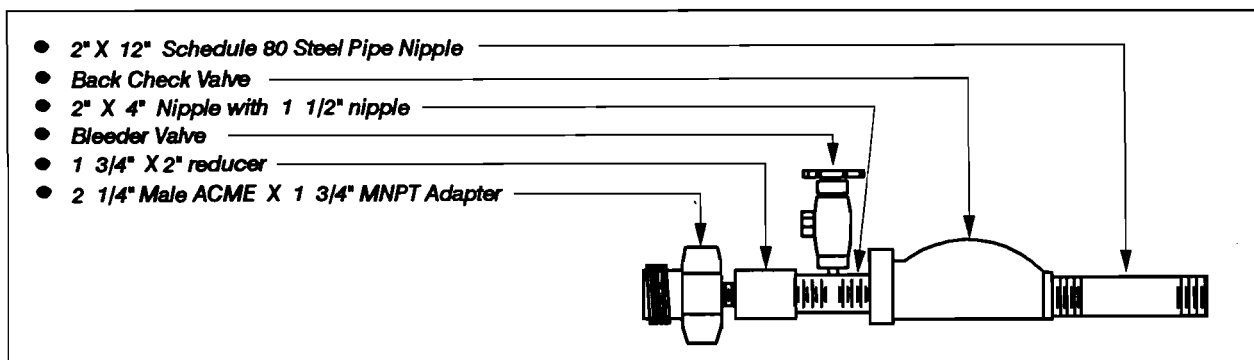

Figure 5-4: Vapor valve inlet assembly for the damaged tank car.

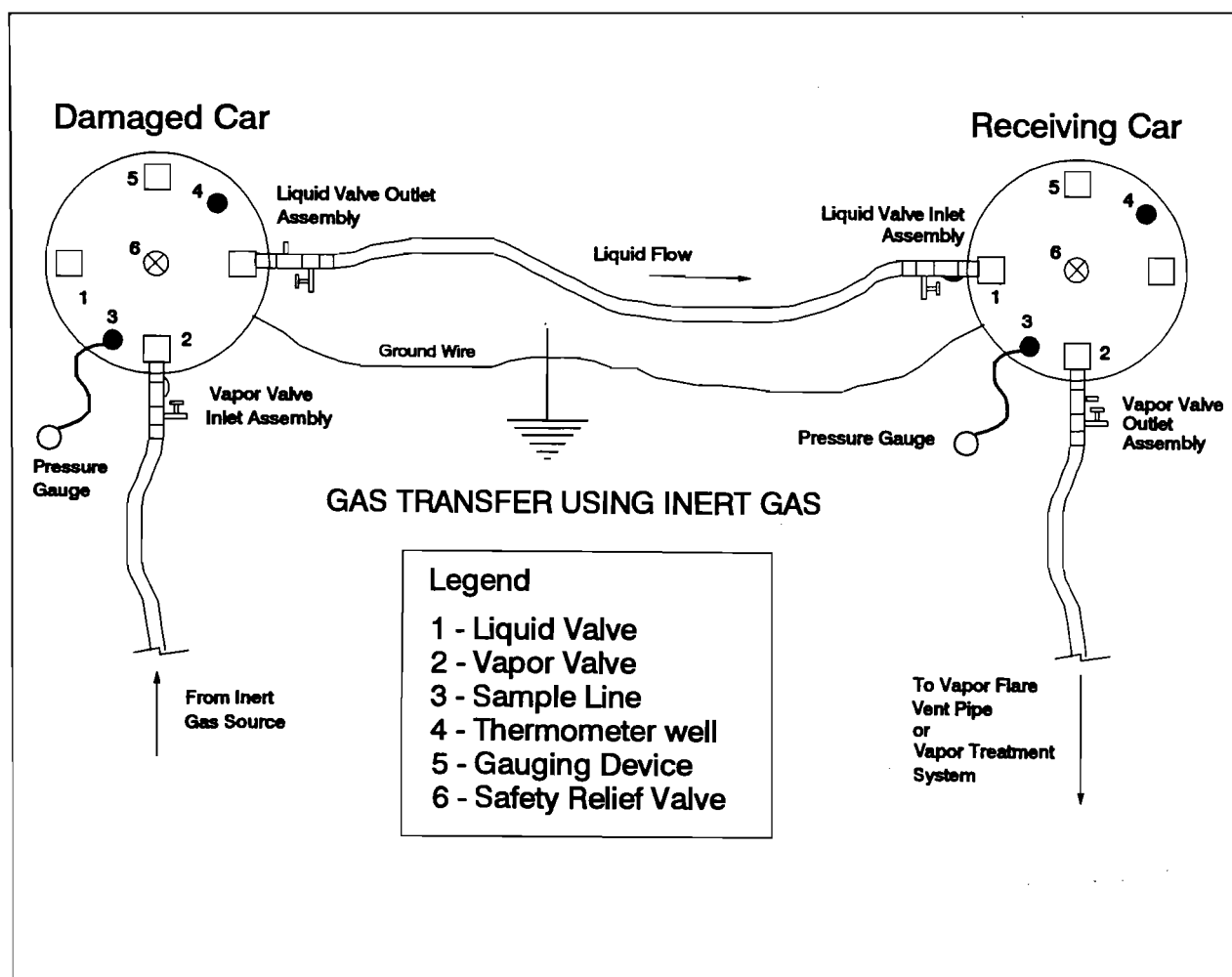

Figure 5-5: Diagram of gas transfer using an inert gas, tank car to tank car. Diagram for similar transfer from tank car to other-than-tank car should be prepared for the situation at hand.

Note: Grounding and bonding are recommended when transferring flammables or combustibles.

General Procedures

Plan the gas transfer operation

1. Determine the capacity of the damaged tank car and the amount of product it contains, then attach a pressure gauge to the sample line or other suitable fitting and determine the internal pressure in the damaged tank car.
2. Obtain a compatible receiving tank, preferably of sufficient capacity to receive the contents of the damaged tank car:
 - a. Check the receiving tank for damage.
 - b. If transferring tank car-to-tank car, verify that the receiving tank is of proper specification and has sufficient capacity to receive the contents of the damaged tank car; if not, obtain additional tanks.
 - c. Verify that any residue in the receiving tank is compatible with the product being transferred.
 - d. Attach a pressure gauge to the sample line or other suitable fitting and determine the internal pressure in the receiving tank.

Note: The receiving tank may contain a small amount of liquid product and vapor at a pressure equal to the vapor pressure at the temperature of the product. If a higher pressure is encountered in the receiving tank, that higher pressure may be from the nitrogen used to unload the previous contents.

3. Prepare a checklist of all equipment required to perform the transfer.
4. Prepare a plan for set-up, implementation, and shut-down of the transfer operation:
 - a. Diagram the location and orientation of the cars involved.
 - b. Diagram the location and orientation of equipment, gauges, hoses, and connections to be used in the transfer.
 - c. Prepare a checklist of the procedures for set-up, implementation, and shut-down of the transfer process.
5. Prepare a site safety plan.
6. Obtain the required transfer equipment.

Set up the gas transfer operation

Note: Since the procedures listed in this section are intended to cover gases in general (both flammable and nonflammable), grounding and bonding is not listed as a general requirement. Please note that grounding and bonding is recommended for flammables and combustibles. See page 60.

1. Hold a safety briefing and discuss items such as:
 - Person in charge;
 - Properties of products;
 - Signals for emergency shut-down;
 - Evacuation routes;
 - Etc.
2. Position the receiving tank and transfer equipment.
3. If the pressure in the receiving tank must be reduced to attain the desired pressure differential and the vapors cannot be put into the damaged tank car, responder should flare, vent, or transfer the vapors to another tank.
4. Connect fittings:
 - a. On the damaged tank car:
 - Clean the male pipe threads and wrap them with pipe joint tape.
Note: When necessary, clean the female threads with a pipe tap.
 - Attach the vapor valve inlet assembly (with check valve) to a vapor valve.
 - Attach the liquid valve outlet assembly (with emergency shut-off valve) to a liquid valve.
 - Position all valve assemblies with the bleeder valve outlet/inlet in a horizontal position and tighten.
 - *Optional:* If used, attach a 90-degree elbow to the liquid valve outlet assembly and tighten with the open end pointed toward the side of the car where the hoses will be attached.
 - b. On the receiving tank:
 - Clean the male pipe threads and wrap them with pipe joint tape.

Set up the gas transfer operation (continued)

Note: When necessary, clean the female threads with a pipe tap.

- Attach the liquid valve inlet assembly (with check valve) to a liquid valve.
- Attach the vapor valve outlet assembly (with emergency shut-off valve) to a vapor valve.
- Position all valve assemblies with the bleeder valve outlet/inlet in a horizontal position and tighten.
- *Optional:* If used, attach a 90-degree elbow to the liquid valve inlet assembly and tighten with the open end pointed toward the side of the car where the hoses will be attached.

5. Set up inert gas supply.
6. Set up vent pipe with a ground control valve or scrubbing equipment.
7. Attach required hoses or piping:

Note: Pipe can be substituted for hose if the damaged tank is stationary on the ground. Because of the possibility of movement, hoses should be used if tanks are on their trucks.

Caution: Clean all hoses and piping as necessary to remove any contaminants that may be present.

- a. Check for "O" rings or gaskets in all hoses and replace if missing or damaged.
- b. Connect liquid hoses directly from the liquid valve outlet assembly on the damaged tank car to the liquid valve inlet assembly on the receiving tank.
- c. Connect vapor hoses from the inert gas supply to the vapor valve inlet assembly on the damaged tank car.
- d. Connect vapor hoses from the vapor valve outlet assembly on the receiving tank to the vent pipe or scrubbing equipment.
- e. Secure the hoses with ropes to reduce strain on the valve assemblies and hose couplings.
- f. Use spanner or "J" wrench or brass hammer to tighten Acme thread couplings.

Set up the gas transfer operation (continued)

8. Purge liquid and vapor hoses and fittings and test for leaks:
 - a. Place the nitrogen cylinder adjacent to the tank car being unloaded and attach the regulator to the nitrogen cylinder.
 - b. Set nitrogen regulator to 50 psi.
 - c. Close all bleeder valves on both cars and the control valves for the vent pipe or the scrubbing equipment.
 - d. Purge the vapor hose and fittings from the receiving tank to the vent pipe or the scrubbing equipment and test for leaks (*purge only if the product is reactive with air or moisture*):
 - Attach one end of a nitrogen hose to the vapor hose bleeder valve at the receiving tank and attach the other end of the hose to the regulator on the nitrogen cylinder.
 - Open the valve on the nitrogen cylinder.
 - Open the vapor hose bleeder valve at the receiving tank.
 - Open the ground control valve for the venting pipe or the control valve for the scrubbing equipment (discharge to atmosphere).
 - Test the discharge from the ground control valve for the vent pipe or the control valve for the scrubbing equipment. *When the oxygen levels falls dramatically, the vapor hose is full of nitrogen.*
 - When the vapor hose is full of nitrogen, close the vapor hose bleeder valve at the damaged tank car, close the vapor hose bleeder valve at the receiving tank, check the hose for leaks. Correct leaks as necessary.
 - Close the valve on the nitrogen cylinder.
 - e. Test the vapor hose from the damaged tank car to the inert gas supply.
 - Open the control valve for the inert gas supply.
 - When the vapor hose is full of inert gas, close the control valve for the inert gas supply, and check the hose for leaks. Correct leaks as necessary.
 - Close the valve to the nitrogen cylinder.
 - f. Purge the liquid hose and fittings and test for leaks (*purge only if the product is reactive with air or moisture*):
 - Attach one end of a nitrogen hose to the liquid hose bleeder valve at the damaged tank car and attach the other end of the hose to the regulator on the nitrogen cylinder.

General Procedures *(continued)*

Set up the gas transfer operation (continued)

- Open the valve on the nitrogen cylinder.
 - Open the liquid hose bleeder valve at the damaged tank car.
 - Open the liquid hose bleeder valve at the receiving tank (discharge to atmosphere).
 - Test the discharge from the liquid hose bleeder valve at the receiving tank with an oxygen meter. *When the oxygen level falls dramatically, the liquid hose is full of nitrogen.*
 - When the liquid hose is full of nitrogen, close the liquid hose bleeder valve at the receiving tank, close the liquid hose bleeder valve at the damaged tank car, and check the liquid hose for leaks.
 - Close the valve on the nitrogen cylinder.
9. Set up the emergency shut-off system, if used, by connecting hoses between all components of the emergency shut-off system..

Implement the gas transfer operation

1. Determine the internal pressure in both the damaged tank car and the receiving tank again.
2. Activate the emergency shut-off system.
3. Start the product flow:
 - a. Fully open the liquid valve on the receiving tank.
 - b. Open the liquid valve on the damaged tank car one-quarter of the way, wait 30 seconds, open the valve half way, wait 30 seconds, then open the valve all the way.
Note: Throughout the transfer operation, all liquid valves should be opened fully to attain maximum flow.
4. Start the vapor flow from the receiving tank to the vent pipe or scrubbing equipment:
 - a. Slowly open the vapor valve on the receiving tank fully.
 - b. Fully open the control valve for the vent pipe or the scrubbing equipment as appropriate.
5. Start the flow of inert gas to the damaged tank car:
 - a. Fully open the control valve for the inert gas supply.
 - b. Fully open the vapor valve on the damaged tank car.
6. Verify that product is flowing from the damaged tank car by:
 - a. Looking for liquid flow in the sight glass;
 - b. Observing the flow indicator; or
 - c. Gauging the car using the gauging device (amount indicates liquid level dropping).
7. Monitor the liquid level in the receiving tank using the gauging device to verify that the tank is not being overfilled.
8. Periodically check for indications that the product flow has ceased:
 - a. Check the sight glass periodically for bubbles. Bubbles indicate the last of the liquid is being withdrawn.
 - c. Observe the flow indicator.
 - d. Watch for buckling of the liquid hose.

Shut down the gas transfer operation

1. When product ceases to flow, shut down the transfer operation:
 - a. Close the control valve for the inert gas supply.
 - b. Allow pressure to equalize.
 - c. Close the vapor valve on the damaged tank car.
 - d. Close the liquid valve on the damaged tank car.
 - e. Close the liquid valve on the receiving tank.
 - f. Close the vapor valve on the receiving tank.
 - g. Close the control valve for the vent pipe or for the scrubbing equipment as appropriate.

2. Purge hoses and/or piping:
 - a. Purge vapor hose from the receiving tank to the vent pipe or the scrubbing equipment as appropriate.
 - Adjust the regulator on nitrogen cylinder to a pressure 15 psi higher than the pressure in the damaged tank car.
 - Open the valve on the nitrogen cylinder.
 - Open the vapor hose bleeder valve at the receiving tank.
 - Open the control valve for the vent pipe or the scrubbing equipment as appropriate.

Note: Test the discharge with an oxygen meter. When the oxygen level falls dramatically, the vapor hose is full of nitrogen.
 - b. When the vapor hose is full of nitrogen:
 - Close the vapor hose bleeder valve at the receiving tank.
 - Close the valve on the nitrogen cylinder.

Shut down the gas transfer operation (continued)

c. Purge liquid hose:

- Adjust the regulator on nitrogen cylinder 15 psi higher than the pressure in the receiving tank.
- Open the valve on nitrogen cylinder.
- Open the liquid hose bleeder valve at the damaged tank car.
- Wait 30 seconds, then open the liquid valve on the receiving tank, wait 30 seconds, and close the liquid valve on the receiving tank.
- Repeat the process four times to remove as much liquid from the liquid hose as possible.
- After repeating the process four times:
 - Close the liquid valve on the receiving tank.
 - Close the liquid hose bleeder valve at the damaged tank car.
 - Close the valve on the nitrogen cylinder.
 - Open the bleeder valves to vent the nitrogen from the hose.

Caution: Some product may remain in the liquid hose after purging, therefore use caution when disassembling and lowering hoses to the ground.

3. Disassemble and clean the transfer equipment.
4. Secure cars (apply plugs in vapor, liquid, and sample line and gauging device valves and tighten with a suitable tool).

This page left blank intentionally

Section 6

Gas Transfer Using Product Vapor Pressure and Flaring

Overview

This product-removal method uses the product's vapor pressure to move the contents of a damaged or overloaded tank car into a receiving tank (e.g., a tank car, cargo tank, or portable tank). In addition, a vapor flare maintains the necessary positive pressure differential between the damaged or overloaded tank car and the receiving tank by burning off vapors in the receiving tank at the outlet of a flare pipe (see Section 8 on vapor flaring). The pressure in the receiving tank is kept as low as possible.

The gas transfer using product vapor pressure and flaring may be used when:

- The tank car tank itself is sound; however, due to bolster or other mechanical damage, the car cannot be safely mounted on its trucks and rerailed;
- The tank car tank itself is sound; however, the site conditions prevent rerailing the damaged tank car (e.g., the terrain does not permit use of cranes or other rerailing equipment);
- The tank car tank is overloaded;
- The damage to leaking valves and fittings cannot be repaired; or
- The tank car tank has been damaged to the extent that it cannot be safely rerailed and moved to an appropriate unloading point.

Note: This transfer method can be accelerated by introducing an inert gas into the damaged or overloaded tank car as the pressure drops; however, the introduction of an inert gas into a damaged tank car may increase the pressure within that car to an unacceptable level.

Preferred Conditions

To the extent possible, the following conditions should exist, or be met, before transferring gases using product vapor pressure and flaring (these conditions are considered optimal, but may not be met in all cases due to local circumstances):

- The contents are flammable;
- A delayed rupture is not likely;
- The tank is not exposed to fire;
- The tank car is in a position that will allow the transfer (e.g., excess flow check valves have not seated, or, if seated, tools are available to unseat them);
- The required liquid and/or vapor valves are accessible and operable (or the use of a hot or cold tap is feasible);
- Receiving tank(s) of the proper specification with sufficient capacity are available to receive the contents of the damaged tank car (any residue in the receiving tank[s] must be compatible with the product to be transferred);
- Suitable transfer equipment is available (*see Required Equipment list on page 79*);
- Personnel experienced in gas transfer and flaring are available; and
- Suitable precautions can be taken to protect people and property in the event of an accidental release during the transfer.

Potential Risks

The following risks may be associated with transferring gases using product vapor pressure and flaring:

- Failure of the tank or transfer equipment that could expose people, property, and the environment to the contents of the damaged tank car;
- Potential contamination of the damaged car's contents that could result in an explosion and fire or the creation of a waste material.

Safety Precautions

The following safety precautions should be taken when transferring a gas using product vapor pressure and flaring:

- Secure the car(s) from movement. Tighten the hand brakes and chock the wheels, if necessary.
- Place blue flags, if required.
- Limit site access to required personnel only.
- Perform transfer using only qualified personnel.
- Check to see that the transfer equipment is clean and appropriate for the product being transferred.
- Clean and wrap all pipe threads with pipe joint tape before making connections.
- Clean all hose connections before joining, replacing “O” rings and gaskets, if necessary.
- Use an emergency shut-off system (“emergency shut-off” and “back check” valves) to either automatically or manually shut down the transfer in case of an unintentional release caused by a hose break or other malfunction. *The use of the emergency shut-off system does not require personnel on the tank during the transfer.*

The emergency shut-off valve is designed to be operated from a remote location. The valve may incorporate a back flow check valve and/or fusible plug or other heat activated device that will automatically close the valve in the event of fire.

The back check valve is designed to prevent backflow in a hose. In the case of a small pressure differential, it may allow some leakage in the reverse direction.

Note: NFPA 58, Standard for Storage and Handling of Liquefied Petroleum Gas, requires emergency shut-off equipment when loading and unloading tank cars of flammable gases.

- Use the appropriate personal protective equipment.
- Monitor the site with the appropriate vapor monitoring equipment.

Safety Precautions *(continued)*

- If the product is flammable or combustible, appropriate fire fighting equipment and extinguishing agents should be available.
- If the product is flammable or combustible, control ignition sources within 15 feet of operations:
 - Do not permit smoking on site.
 - Eliminate or shut off any electrical equipment that is not intrinsically safe.
 - Shut off any internal-combustion engines that are not intrinsically safe.

Note: A gas transfer using product vapor under pressure and flaring is considered an open system. NFPA 77, Recommended Practice on Static Electricity, recommends grounding and bonding when loading and unloading flammables or combustibles from tank cars using open systems.

Required Equipment

Tools and supplies

Minimum	Desired	
1	2	36" pipe wrench.
1	2	24" pipe wrench.
1	2	10" pipe wrench.
1	2	12" adjustable wrench.
1	2	Spanner or "J" wrench or brass hammer (appropriate for couplings on the hoses used).
2	2	1/4" pressure gauges with pressure range suitable for product being transferred.
1	1	Oxygen meter.
1	1	Explosimeter.
1	1	Armored thermometer with chain (<i>optional</i>).
1	1	Paint scraper.
1	1	Wire brush.
1	2	Rolls of pipe joint tape.
1	1	Roll of duct tape.
1	2	Spray bottle containing commercial leak detector or a solution of dishwashing soap.
6	8	25' length of rope.
1	2	Tool bag.
1	1	6' copper grounding rod.
2	2	6'-8' grounding straps with clamps.

Required Equipment *(continued)*

Fittings and other gas transfer and flaring equipment

Minimum	Desired	
1	1	Liquid valve outlet assembly [See Figure 6-1].
1	1	Liquid valve inlet assembly [See Figure 6-2].
1	1	Vapor valve outlet assembly [See Figure 6-3].
1	1	Vapor valve inlet assembly, if using an inert gas [See Figure 6-4].
(3)	(3)	3" to 2" bushing (when cars are equipped with 3" valves).
3	3	90-degree steel elbows <i>(optional)</i> .
Sufficient		Lengths of liquid hose or Schedule 80 steel pipe with appropriate connectors.
Sufficient		Lengths of vapor hose or Schedule 80 steel pipe with appropriate connectors from the vapor line on the receiving tank to the flare stand <i>(150 feet)</i> .
Sufficient		"O" rings or gaskets for liquid and vapor hoses.
		Notes:
		<ul style="list-style-type: none"> • <i>Hose material, "O" rings, and fittings must be compatible with the product.</i> • <i>Hoses for liquefied petroleum gas should not be interchanged with hoses used for anhydrous ammonia.</i>
Sufficient		1/4" nitrogen hose for purging and testing for leaks in liquid and vapor hoses (including adapters for the bleeder valves on one end and for the nitrogen regulator outlet on the other end). Hose should be able to handle pressures above that found in the tank.

Required Equipment *(continued)*

Fittings and other gas transfer and flaring equipment (continued)

Minimum	Desired	
	Sufficient	
1	1	Nitrogen hose for emergency shut-off system (minimum operating pressure of 50 psi).
1	1	Four-way fitting for the nitrogen hose for emergency shut-off system.
1	1	Control switch for emergency shut-off system.
1	2	Nitrogen regulators, 0-300 psi.
1	2	Cylinder of nitrogen.
1	2	Liquid sight glass or flow indicator (<i>optional</i>)—use only if approved in company operating procedures.
1	1	Source of inert gas (<i>optional</i>).
1	1	Flare stack (see Figure 8-3).

Gas Transfer Using Product Vapor Pressure and Flaring

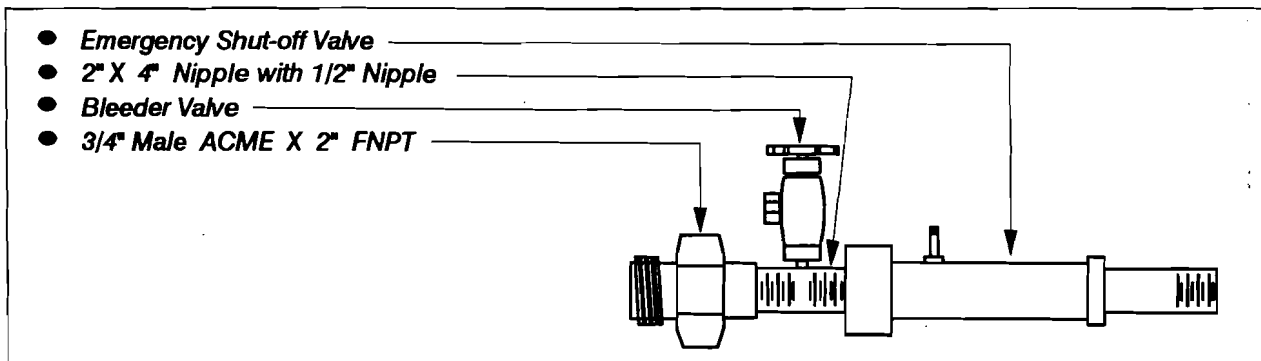

Figure 6-1: Liquid valve outlet assembly for the damaged tank car.

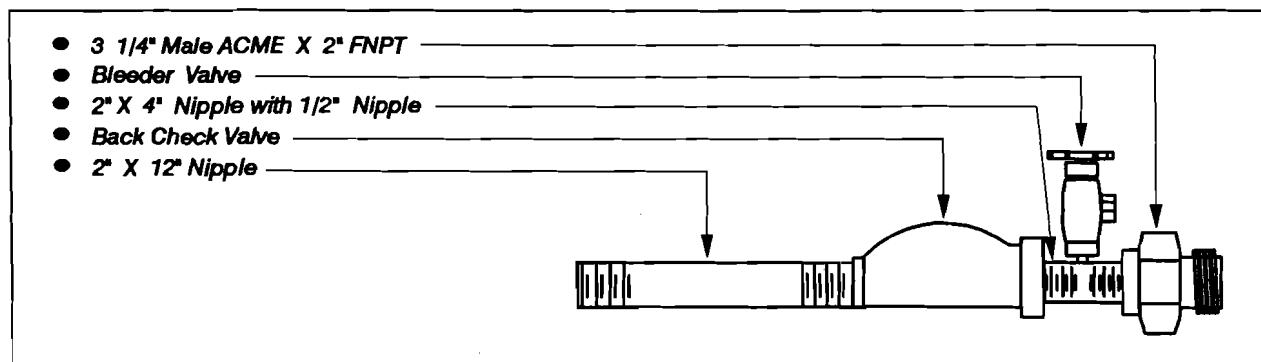

Figure 6-2: Liquid valve inlet assembly for the receiving tank.

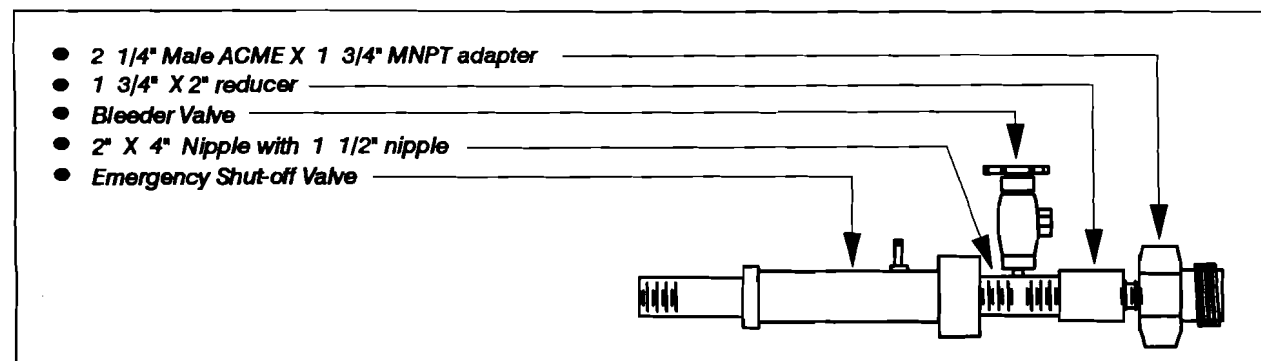

Figure 6-3: Vapor valve outlet assembly for the receiving tank.

Gas Transfer Using Product Vapor Pressure and Flaring

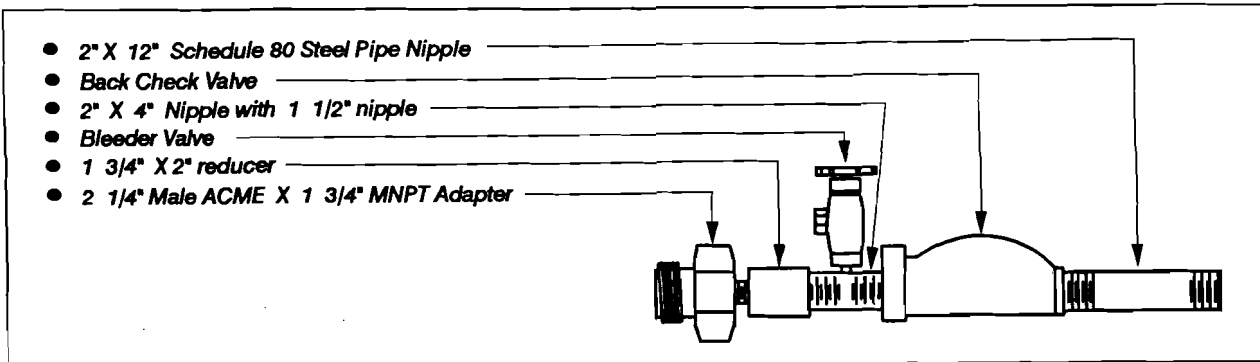

Figure 6-4: Vapor valve inlet assembly for the damaged tank car (if using an inert gas).

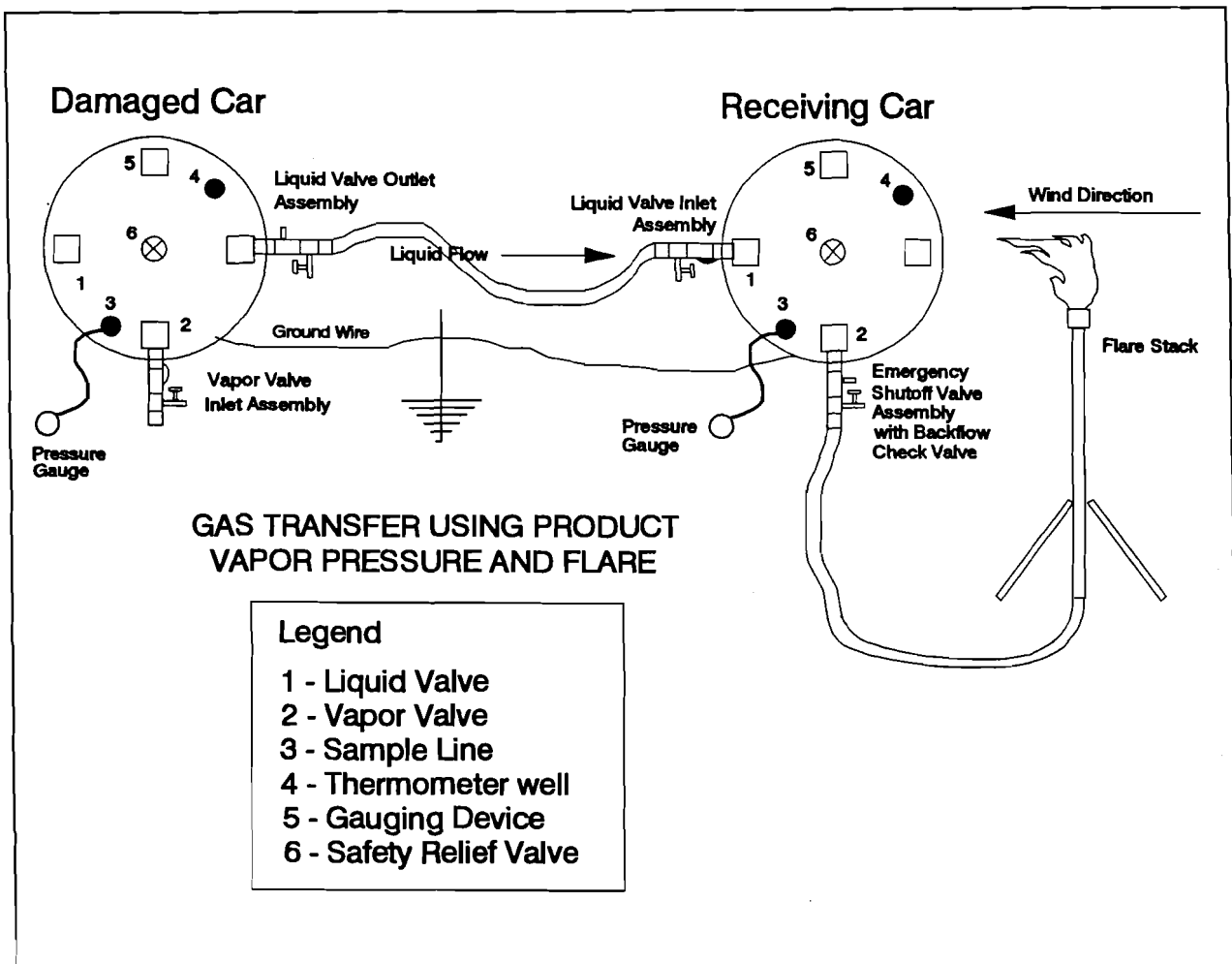

Figure 6-5: Diagram of gas transfer using vapor pressure and flaring, tank car to tank car (with optional use of inert gas). Diagram for similar transfer from tank car to other-than-tank car should be prepared for the situation at hand.

Note: Grounding and bonding is recommended when transferring flammables or combustibles.

Plan the gas transfer operation

1. Determine the capacity of the damaged tank car and the amount of product it contains, then attach a pressure gauge to the sample line or other suitable fitting and determine the internal pressure in the damaged tank car.
2. Obtain a compatible receiving tank, preferably of sufficient capacity to receive the contents of the damaged tank car:
 - a. Check the receiving tank for damage.
 - b. If transferring tank car-to-tank car, verify that the receiving tank is of the proper specification and has sufficient capacity to receive the contents of the damaged tank car; if not, obtain additional tanks.
 - c. Verify that any residue in the receiving tank is compatible with the product being transferred.
 - d. Attach a pressure gauge to the sample line or other suitable fitting and determine the internal pressure in the receiving tank.

Note: The receiving tank may contain a small amount of liquid product and vapor at a pressure equal to the vapor pressure at the temperature of the product. If a higher pressure is encountered in the receiving tank, that higher pressure may be from the nitrogen used to unload the previous contents.

3. Prepare a checklist of all equipment required to perform the transfer.
4. Prepare a plan for set-up, implementation, and shut-down of the transfer operation:
 - a. Diagram the location and orientation of the cars involved.
 - b. Diagram the location and orientation of equipment, gauges, hoses, and connections to be used in the transfer.
 - c. Prepare a checklist of the procedures for set-up, implementation, and shut-down of the transfer process.
5. Prepare a site safety plan.
6. Obtain the required transfer equipment.

Set up the gas transfer operation

1. Hold a safety briefing and discuss items such as:
 - Person in charge;
 - Properties of products;
 - Signals for emergency shut-down;
 - Evacuation routes;
 - Etc.
2. Position the receiving tank and transfer equipment.
3. Ground and bond the tanks:
 - a. Drive the grounding rod at least 3' into the ground.
 - b. Attach one end of a grounding strap to the damaged car and attach the other end to the grounding rod.
 - c. Attach one end of a grounding strap to the receiving tank and attach the other end to the grounding rod.
4. Connect fittings.
 - a. On the damaged tank car:
 - Clean the male pipe threads and wrap them with pipe joint tape.
Note: When necessary, clean the female threads with a pipe tap.
 - Attach the liquid valve outlet assembly (with emergency shut-off valve) to a liquid valve.
 - Position all valve assemblies with the bleeder valve outlet/inlet in a horizontal position and tighten.
 - *Optional:* If used, attach a 90-degree elbow to the liquid valve outlet assembly and tighten with the open end pointed toward the side of the car where the hoses will be attached.
 - b. On the receiving tank:
 - Clean the male pipe threads and wrap them with pipe joint tape.
Note: When necessary, clean the female threads with a pipe tap.
 - Attach the liquid valve inlet assembly (with check valve) to a liquid valve.

Set up the gas transfer operation (continued)

- Attach the vapor valve outlet assembly (with emergency shut-off valve) to a vapor valve.
 - Position all valve assemblies with the bleeder valve outlet/inlet in a horizontal position and tighten.
 - *Optional:* If used, attach a 90-degree elbow to the liquid valve inlet assembly and tighten with the open end pointed toward the side of the car where the hoses will be attached.
- c. Set up flare stand and ground control valve.
5. Attach required hoses or piping:
- Note: Pipe can be substituted for hose if the damaged tank is stationary on the ground. Because of the possibility of movement, hoses should be used if tanks are on their trucks.*
- Caution: Clean all hoses and piping as necessary to remove any contaminants that may be present.*
- a. Check for “O” rings or gaskets in all hoses and replace if missing or damaged.
- b. Attach the liquid and vapor hoses to both tanks:
- Connect liquid hoses directly from the liquid valve outlet assembly on the damaged tank car to the liquid valve inlet assembly on the receiving tank.
 - Connect vapor hoses from the vapor valve outlet assembly on the receiving tank to the ground control valve inlet for the flare stand, then from the ground control valve outlet to the flare stand.
- c. Secure the hoses with ropes to reduce strain on the valve assemblies and hose couplings.
- d. Use spanner or “J” wrench or brass hammer to tighten Acme thread couplings.
6. Purge liquid and vapor hoses and fittings and test for leaks:
- a. Place the nitrogen cylinder adjacent to the tank car being unloaded and attach the regulator to the nitrogen cylinder.
- b. Set nitrogen regulator to 50 psi.
- c. Close all bleeder valves on both cars.
- d. Test the vapor hose from the receiving tank to the ground control valve for leaks.

General Procedures *(continued)*

Set up the gas transfer operation (continued)

- Attach one end of a nitrogen hose to the vapor hose bleeder valve at the receiving tank and attach the other end of the hose to the regulator on the nitrogen cylinder.
 - Open the valve on the nitrogen cylinder.
 - Open the vapor hose bleeder valve at the receiving tank.
 - Open the ground control valve at the base of the flare stand (discharge to atmosphere).
 - When the vapor hose is full of nitrogen, close the vapor hose bleeder valve at the receiving tank, and check the hose for leaks. Correct leaks as necessary.
 - Close the valve on the nitrogen cylinder.
- e. Purge the liquid hose and fittings and test for leaks (*purge only if the product is reactive with air or moisture*):
- Attach one end of a nitrogen hose to the liquid hose bleeder valve on the damaged tank car and attach the other end of the hose to the regulator on the nitrogen cylinder.
 - Open the valve on the nitrogen cylinder.
 - Open the liquid hose bleeder valve at the damaged tank car.
 - Open the liquid hose bleeder valve at the receiving tank and discharge to atmosphere.
 - Test the discharge from the liquid hose bleeder valve at the receiving tank with an oxygen meter. *When oxygen level falls dramatically, the liquid hose is full of nitrogen.*
 - When the liquid hose is full of nitrogen, (1) close the liquid hose bleeder valve at the receiving tank, (2) close the liquid hose bleeder valve at the damaged tank car, (3) check the liquid hose for leaks. Correct leaks as necessary.
 - Close the valve on the nitrogen cylinder.
7. Set up the emergency shut-off system, if used, by connecting hoses between all components of the emergency shut-off system.

Implement the gas transfer operation

1. Determine the internal pressure in both the damaged tank car and the receiving tank again.
2. Activate the emergency shut-off system.
3. Start the product flow:
 - a. Fully open the liquid valve on the receiving tank.
 - b. Open the liquid valve on the damaged tank car one-quarter of the way, wait 30 seconds, open the valve half way, wait 30 seconds, then open the valve all the way.
Note: Throughout the transfer operation, all liquid valves should be opened fully for maximum flow.
4. Start the vapor flow to the flare pipe and ignite discharging vapors:
 - a. Fully open the vapor valve on the receiving tank.
 - b. Fully open the ground control valve at the base of the flare stand.
 - c. Ignite the discharging vapors.
5. Verify that product is flowing from the damaged tank car by:
 - a. Looking for liquid flow in the sight glass.
 - b. Observing the flow indicator, or
 - c. Gauging the car using the gauging device (amount indicates liquid level dropping).
6. Monitor the liquid level in the receiving tank using the gauging device to verify that the tank is not being overfilled.
7. Periodically check for indications that the product flow has ceased:
 - a. Check the sight glass periodically for bubbles. Bubbles indicate the last of the liquid is being withdrawn.
 - b. Observe the flow indicator.
 - c. Watch for buckling of the liquid hose.

Shut down the gas transfer operation

1. When liquid ceases to flow, shut down the transfer operation.
 - a. Close the liquid valve on the damaged tank car.
 - b. Close the liquid valve on the receiving tank.
 - c. Close the vapor valve on the receiving tank.

2. Purge liquid hose:
 - a. Adjust the regulator on nitrogen cylinder 15 psi higher than the pressure in the receiving tank.
 - b. Open the valve on nitrogen cylinder.
 - c. Open the liquid hose bleeder valve at the damaged tank car.
 - d. Wait 20 seconds, then open the liquid valve on the receiving tank, wait 20 seconds and close the liquid valve on the receiving tank.
 - e. Repeat the process four times to remove as much liquid from the liquid hose as possible.
 - f. After repeating the process four times:
 - Close the liquid valve on the receiving tank.
 - Close the liquid hose bleeder valve at the damaged tank car.
 - Close the valve on the nitrogen cylinder.
 - Open bleeder valve to vent the nitrogen from the hose.

Note: Some liquid may remain in the liquid hose after purging, therefore use caution when disassembling and lowering hoses to the ground.

3. Purge the vapor hose from the receiving tank to the flare stand:
 - a. Adjust the regulator on nitrogen cylinder 15 psi higher than the pressure in the receiving tank car.
 - b. Open the valve on the nitrogen cylinder.
 - c. Open the vapor hose bleeder valve at the receiving tank.
 - d. Open the ground control valve at the base of the flare stand.

Note: Since the product is flammable, test the discharge with an Explosimeter. When the Explosimeter does not pick up explosive concentrations in the discharge from the bleeder valve, the vapor hose is full of nitrogen.
 - e. Close the vapor hose bleeder valve at the receiving tank.
 - f. Close the valve on the nitrogen cylinder.

General Procedures *(continued)*

Shut down the transfer operation (continued)

3. Disassemble and clean the transfer and flaring equipment.
Note: Flare stand will be hot, therefore allow sufficient time for it to cool before disassembly.
4. Secure cars (apply plugs in vapor, liquid, sample line, and gauging device valves and tighten with a suitable tool).

Section 7

Liquid Transfer Using a Liquid Pump

Overview

This transfer method uses a liquid pump to move the contents of a damaged or overloaded tank car into a receiving tank (e.g., a tank car, cargo tank, or portable tank). The liquid pump may be supplemented by gravity, an inert gas, a vacuum (e.g., vacuum truck), or any combination thereof.

The liquid transfer using a liquid pump may be used when:

- The tank car tank itself is sound; however, due to bolster or other mechanical damage, the car cannot be safely mounted on its trucks and railed;
- The tank car tank itself is sound; however, the site conditions prevent rerailing the damaged tank car (e.g., the terrain does not permit use of cranes or other rerailing equipment);
- The tank car tank is overloaded;
- The damage to leaking valves and fittings cannot be repaired; or
- The tank car tank has been damaged to the extent that it cannot be safely railed and moved to an appropriate unloading point.

Note: The liquid pump does not increase the pressure within the damaged tank car, unless another means of creating a positive pressure differential (vapor compressor or inert gas) is used.

Preferred Conditions

To the extent possible, the following conditions should exist, or be met, before transferring liquids using a liquid pump (these conditions are considered optimal, but may not be met in all cases due to local circumstances):

- The tank is not exposed to fire—or, if the tank car tank was exposed to fire, the contents have cooled sufficiently to prevent damage to the equipment used in the transfer;
- The tank car is in a position that will allow the transfer;
- The required fittings and/or bottom outlet are accessible and operable (or the use of a hot tap is feasible);
- Receiving tank(s) of the proper specification with sufficient capacity are available to receive the contents of the damaged tank car (any residue in the receiving tank[s] must be compatible with the product to be transferred);
- Suitable transfer equipment is available (*see Required Equipment list on page 95*);
- Personnel experienced in liquid transfers are available; and
- Suitable precautions can be taken to protect people and property in the event of an accidental release during the transfer.

Potential Risks

The following risks may be associated with transferring liquids using a liquid pump:

- Failure of the tank or transfer equipment that could expose people, property, and the environment to the contents of the damaged tank car;
- Potential contamination of the damaged car's contents that could result in an explosion and fire or the creation of a waste material.

Safety Precautions

- Secure the car(s) from movement. Tighten the hand brakes and chock the wheels, if necessary.
- Place blue flags, if required.
- Limit site access to required personnel only.
- Perform transfer using only qualified personnel.
- Check to see that the transfer equipment is clean and appropriate for the product being transferred.
- Clean and wrap all pipe threads with pipe joint tape before making connections.
- Clean all hose connections before joining, replacing “O” rings and gaskets, if necessary.
- Use an emergency shut-off system (“emergency shut-off” and “back check” valves) to either automatically or manually shut down the transfer in case of an unintentional release caused by a hose break or other malfunction. *The use of the emergency shut-off system does not require personnel on the tank during the transfer.*

The emergency shut-off valve is designed to be operated from a remote location. The valve may incorporate a back flow check valve and/or fusible plug or other heat activated device that will automatically close the valve in the event of fire.

The back check valve is designed to prevent backflow in a hose. In the case of a small pressure differential, it may allow some leakage in the reverse direction.

Note: NFPA 58, Standard for Storage and Handling of Liquefied Petroleum Gas, requires emergency shut-off equipment when loading and unloading tank cars of flammable gases.

- Use the appropriate personal protective equipment.
- Monitor the site with the appropriate vapor monitoring equipment.

Safety Precautions *(continued)*

- If the product is flammable or combustible, appropriate fire fighting equipment and extinguishing agents should be available, and
- If the product is flammable or combustible, control ignition sources within 15 feet of operations:
 - Do not permit smoking on site.
 - Eliminate or shut off any electrical equipment that is not intrinsically safe.
 - Shut off any internal-combustion engines that are not intrinsically safe.

Note: A liquid transfer using a liquid pump may be considered an open system. NFPA 77 requires grounding and bonding when loading and unloading tank cars through open systems.

Required Equipment

Tools and supplies

Minimum	Desired	
1	2	36" pipe wrench.
1	2	24" pipe wrench.
1	2	12" adjustable wrench.
1	2	Spanner or "J" wrench or brass hammer (appropriate for couplings on the hoses used).
1	2	Pair of pliers.
0	1	Oxygen meter (<i>optional</i>).
1	1	Explosimeter.
1	1	Paint scraper.
1	1	Wire brush.
1	2	Rolls of pipe joint tape.
1	1	Roll of duct tape.
1	2	Spray bottle containing commercial leak detector or a solution of dishwashing soap.
6	8	25' length of rope.
1	1	6' copper grounding rod.
2	2	6'-8' grounding straps with pressure point clamps.

Required Equipment *(continued)*

Fittings and other liquid transfer equipment

Minimum	Desired	
1	2	Liquid valve outlet assembly [See Figure 7-1].
1	2	Liquid valve inlet assembly [See Figure 7-2].
1	1	Vapor valve outlet assembly [See Figure 7-3].
1	1	Vapor valve inlet assembly [See Figure 7-4].
(4)	(4)	3" to 2" bushing (when cars are equipped with 3" valves).
(1)	(1)	2" gate valve for the discharge end of the liquid hose when transferring to a cargo tank or portable tank (for wet line operation).
(1)	(1)	Adapter to cargo tank or portable tank liquid hose.
2	4	90-degree elbows <i>(optional)</i> .
Sufficient		Lengths of liquid hose or Schedule 80 steel pipe with appropriate connectors.
Sufficient		Lengths of vapor hose or Schedule 80 steel pipe with appropriate connectors.
Sufficient		"O" rings or gaskets for liquid and vapor hoses.
		<i>Note: Hose material, "O" rings, and fittings must be compatible with the product.</i>
Sufficient		1/4" nitrogen hose for purging and testing for leaks in liquid and vapor hoses (including adapters for the bleeder valves on one end and for the nitrogen regulator outlet on the other end). Hose should be able to handle pressures above that found in the tanks.
Sufficient		Nitrogen hose for emergency shut-off system (minimum operating pressure of 50 psi).

Required Equipment *(continued)*

Fittings and other liquid transfer equipment (continued)

Minimum	Desired	
1	1	Four-way fitting for the nitrogen hose for emergency shut-off system.
1	1	Control switch for emergency shut-off system.
1	2	Nitrogen regulators, 0-300 psi.
1	2	Cylinder of nitrogen.
1	2	Liquid sight glass or flow indicator <i>(optional)</i> —use only if approved in company operating procedures.
1	1	Liquid pump (powered by an explosion proof motor (air or other inert gas operated) and equipped with Schedule 80 steel pipe nipples with bleeder valves and adapters to liquid hose at the inlet and outlets.

Because of the wide range of products, valve and fitting arrangements, and situations, it is impractical to specify all of the combinations of equipment that may be used to perform a liquid transfer. Persons contemplating a liquid transfer must make their own equipment list based upon consultation with the shipper, their own analysis of the appropriate methods, and the equipment available. Other considerations include properties of the product, and of other non-metallic parts (gaskets, seals, etc.).

Liquid Transfer Using a Liquid Pump

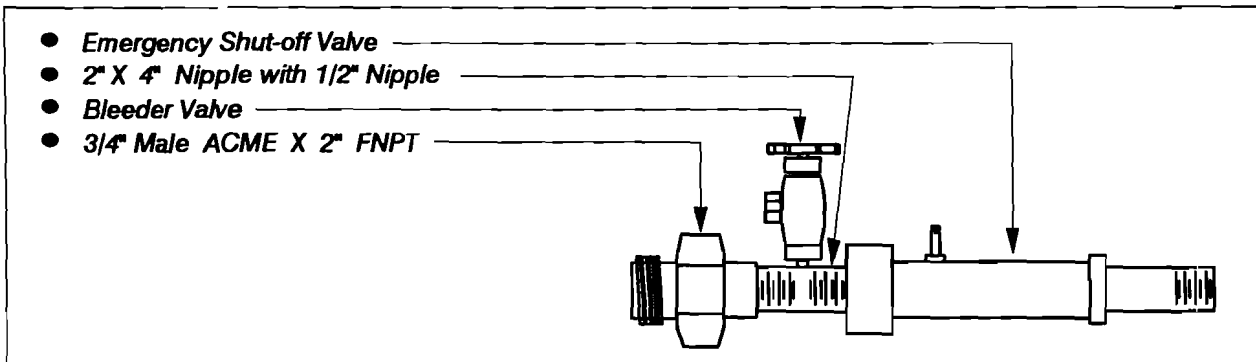

Figure 7-1: Liquid valve outlet assembly for the damaged tank car.

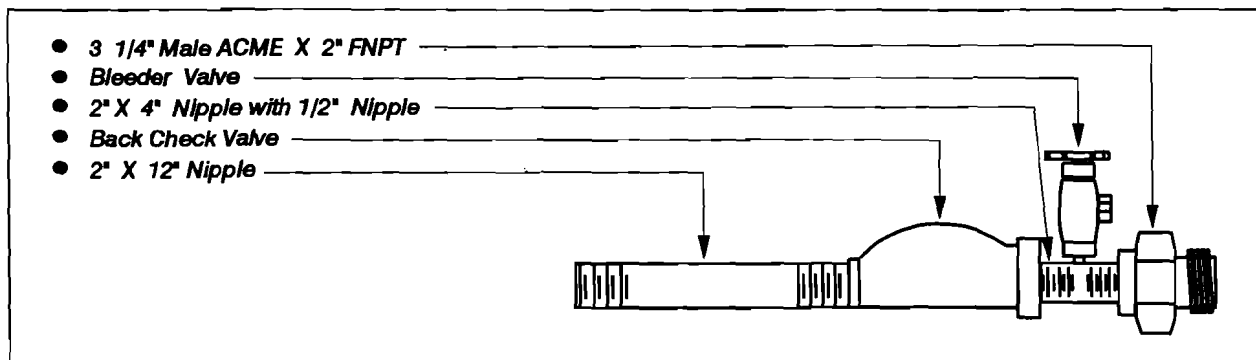

Figure 7-2: Liquid valve inlet assembly for the receiving tank.

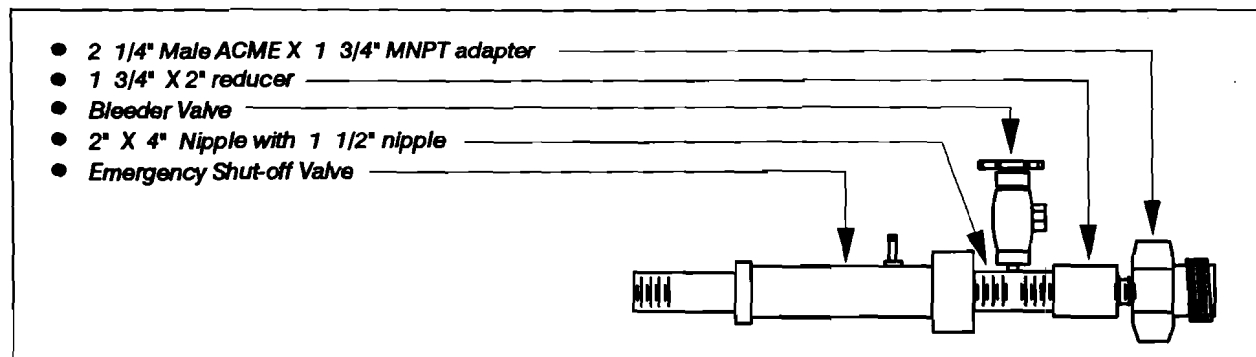

Figure 7-3: Air valve outlet assembly for the receiving tank.

Liquid Transfer Using a Liquid Pump

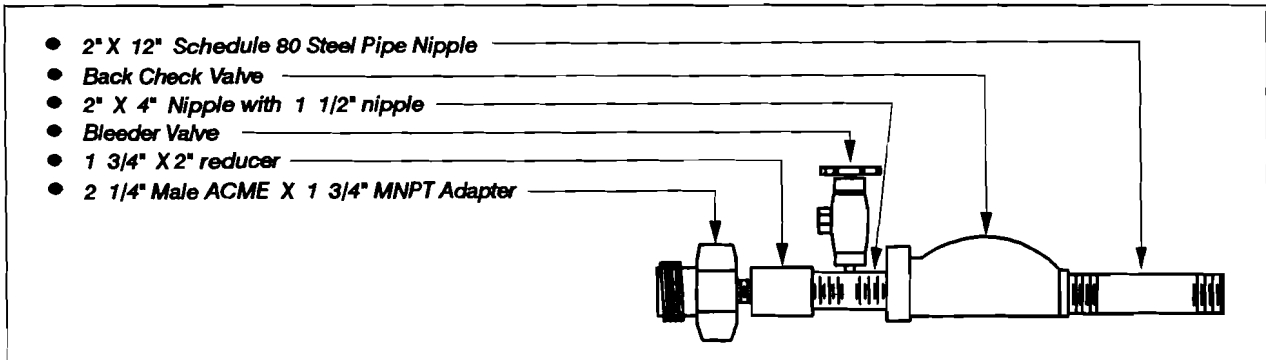

Figure 7-4: Air valve inlet assembly for the damaged tank car.

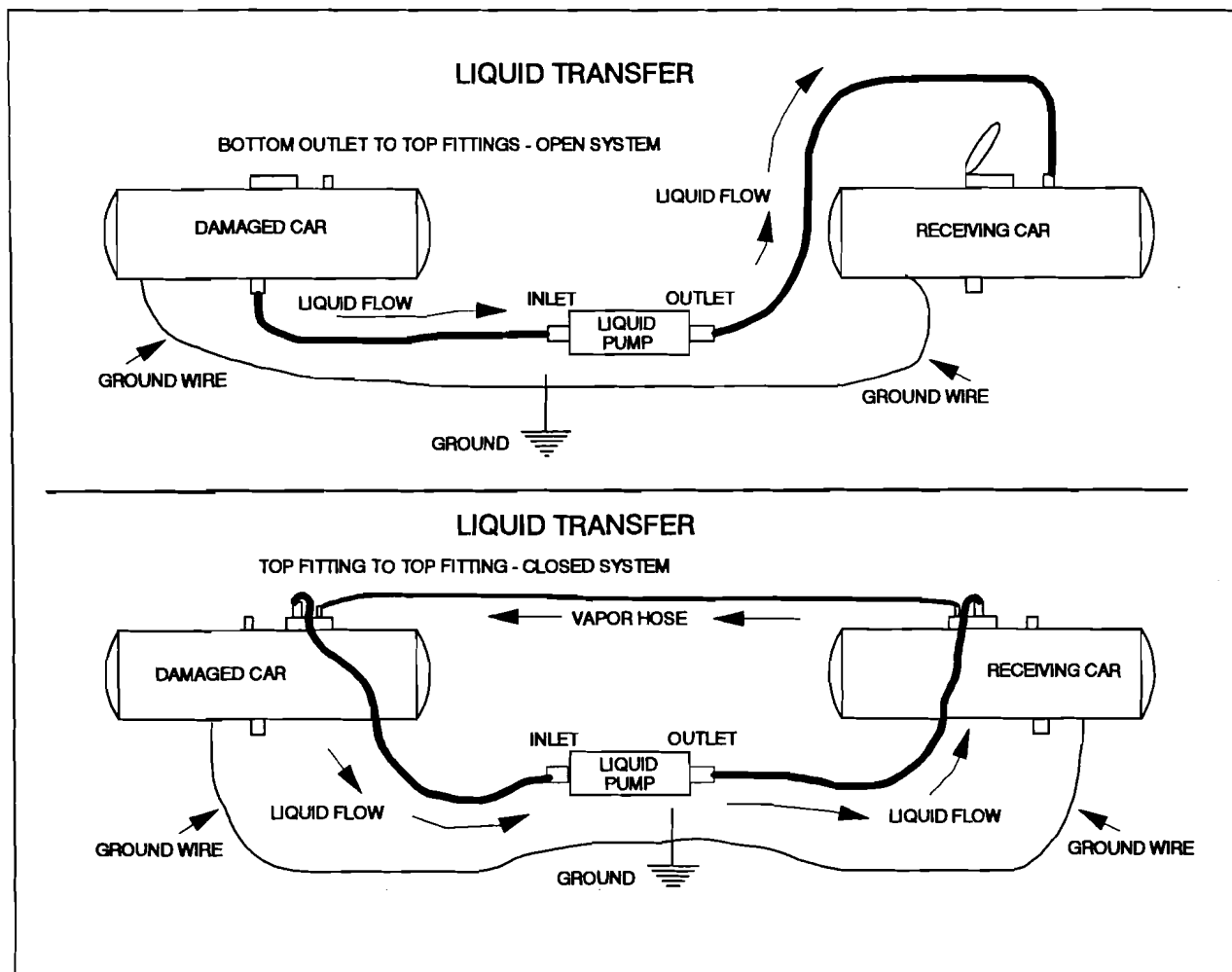

Figure 7-5: Diagram of liquid transfer using a liquid pump, tank car to tank car. Diagram of similar transfer from tank car to other-than-tank car should be prepared for the situation at hand.

Note: Grounding and bonding is recommended when transferring flammables or combustibles.

General Procedures

Plan the liquid transfer operation

1. Determine the capacity of the damaged tank car and the amount of product it contains, then attach a pressure gauge to the sample line or other suitable fitting and determine the internal pressure in the damaged tank car.
2. Obtain a compatible receiving tank, preferably of sufficient capacity to receive the contents of the damaged tank car:
 - a. Check the receiving tank for damage.
 - b. If transferring tank car-to-tank car, verify that the receiving tank is of proper specification and has sufficient capacity to receive the contents of the damaged tank car; if not, obtain additional tanks.
 - c. Verify that any residue in the receiving tank is compatible with the product being transferred.
 - d. Attach a pressure gauge to the sample line or other suitable fitting and determine the internal pressure in the receiving tank.

Note: The receiving tank may contain a small amount of liquid product and vapor at a pressure equal to the vapor pressure of the product at the temperature of the product. If a higher pressure is encountered in the receiving tank, that higher pressure may be from the nitrogen used to unload the previous contents.

3. Prepare a checklist of all equipment required to perform the transfer.
4. Prepare a plan for set-up, implementation, and shut-down of the liquid transfer operation:
 - a. Diagram the location and orientation of the cars involved.
 - b. Diagram the location and orientation of equipment, gauges, hoses, and connections to be used in the liquid transfer.
 - c. Prepare a checklist of the procedures for set-up, implementation, and shut-down of the liquid transfer process.
5. Prepare a site safety plan.
6. Obtain the required transfer equipment.

Set up the liquid transfer operation

1. Hold a safety briefing and discuss items such as:
 - Person in charge.
 - Properties of products.
 - Signals for emergency shut-down.
 - Evacuation routes.
 - Etc.
2. Position the receiving tank and transfer equipment.
3. If an open system, ground and bond the tanks:
 - a. Drive the grounding rod at least 3' into the ground.
 - b. Attach one end of a grounding strap to the damaged tank car and attach the other end to the grounding rod.
 - c. Attach one end of a grounding strap to the receiving tank and attach the other end to the grounding rod.
4. To prevent a vacuum from forming in the damaged tank car and to prevent pressure build-up in the receiving tank, either:
 - a. Connect the vapor valves on both tanks with hose, or
 - b. Open a top fitting on each tank to prevent adverse pressure effects (overpressure or vacuum).
5. Connect fittings:
 - a. On the damaged tank car:
 - Clean the male pipe threads and wrap them with pipe joint tape.
Note: When necessary, clean the female threads with a pipe tap.
 - Attach the vapor valve inlet assembly (with check valve) to an air valve.
 - Attach the liquid valve outlet assembly (with emergency shut-off valve) to a liquid valve.
 - Position all valve assemblies with the bleeder valve outlet/inlet in a horizontal position and tighten, and
 - *Optional:* If used, attach a 90-degree elbow to the liquid valve outlet assembly and tighten with the open end pointed toward the side of the car where the hoses will be attached.

Set up the liquid transfer operation (continued)

b. On the receiving tank:

- Clean the male pipe threads and wrap them with pipe joint tape.

Note: When necessary, clean the female threads with a pipe tap.

- Attach the liquid valve inlet assembly (with check valve) to a liquid valve.
- Attach the vapor valve outlet assembly (with emergency shut-off valve) to an air valve.
- Position all valve assemblies with the bleeder valve outlet/inlet in a horizontal position and tighten, and
- *Optional:* If used, attach a 90-degree elbow to the liquid valve inlet assembly and tighten with the open end pointed toward the side of the car where the hoses will be attached.

6. Attach required hoses and/or piping.

Note: Pipe can be substituted for hose if the damaged tank is stationary on the ground. Because of the possibility of movement, hoses should be used if tanks are on their trucks.

Caution: Clean all hoses and piping as necessary to remove any contaminants that may be present.

- a. Check for "O" rings or gaskets in all hoses and replace if missing or damaged.
- b. Connect liquid hoses directly from the liquid valve outlet assembly on the damaged tank car to the liquid pump inlet, then from the liquid pump outlet to a liquid valve inlet assembly on the receiving tank.
- c. Connect vapor hose from the air valve outlet assembly on the receiving tank to the air valve inlet assembly on the damaged tank car.
- d. Secure the hoses with ropes to reduce strain on the valve assemblies and hose couplings.
- e. Use spanner or "J" wrench or brass hammer to tighten Acme thread couplings.

Set up the liquid transfer operation (continued)

7. Purge liquid and vapor hoses and fittings and test for leaks:
 - a. Attach the regulator to the nitrogen cylinder and place it between the tanks.
 - b. Set nitrogen regulator to 50 psi.
 - c. Close all bleeder valves on both cars.
 - d. Purge the vapor hose and fittings and test for leaks (*purge only if the product is reactive with air or moisture*):
 - Attach one end of a nitrogen hose to the vapor hose bleeder valve at the receiving tank and attach the other end of the hose to the regulator on the nitrogen cylinder.
 - Open the valve on the nitrogen cylinder.
 - Open the vapor hose bleeder valve at the receiving tank.
 - Open the vapor hose bleeder valve at the damaged tank car (discharge to atmosphere).
 - Test the discharge from the vapor hose bleeder valve at the damaged tank car with an oxygen meter. *When the oxygen level falls dramatically, the vapor hose is full of nitrogen.*
 - When the vapor hose is full of nitrogen, (1) close the vapor hose bleeder valve at the damaged tank car, (2) close the vapor hose bleeder valve at the receiving tank, (3) check the hose for leaks. Correct leaks as necessary.
 - Close the valve on the nitrogen cylinder.
 - e. Purge the liquid hose and fittings and test for leaks (*purge only if the product is reactive with air or moisture*):
 - Attach one end of a nitrogen hose to the liquid hose bleeder valve at the damaged tank car and attach the other end of the hose to the regulator on the nitrogen cylinder.
 - Open the valve on the nitrogen cylinder.
 - Open the liquid hose bleeder valve at the damaged tank car.
 - Open the liquid hose bleeder valve at the receiving tank (discharge to atmosphere).

General Procedures *(continued)*

Set up the liquid transfer operation (continued)

- Test the discharge from the liquid hose bleeder valve at the receiving tank with an oxygen meter. *When oxygen level falls dramatically, the liquid hose is full of nitrogen.*
 - When the liquid hose is full of nitrogen, (1) close the liquid hose bleeder valve at the receiving tank, (2) close the liquid hose bleeder valve at the damaged tank car, (3) check the liquid hose for leaks. Correct leaks as necessary.
 - Close the valve on the nitrogen cylinder.
8. Set up the emergency shut-off system, if used, by connecting hoses between all components of the emergency shut-off system.

Implement the liquid transfer operation

1. Determine the internal pressure in both the damaged tank car and the receiving tank again.
2. Activate the emergency shut-off system.
3. Open valves required for pressure or vacuum relief.
4. Start flow of product from damaged tank car:
 - a. Start the vapor flow:
 - Fully open the air valve on the receiving tank.
 - Fully open the air valve on the damaged tank car.
 - b. Start liquid flow:
 - Fully open the liquid valve on the receiving tank.
 - Fully open the liquid valve on the damaged tank car.

Note: Throughout the transfer operation, all liquid valves should be opened fully to attain maximum flow.
5. Start the liquid pump.
6. Verify that product is flowing from the damaged tank car by:
 - a. Looking for liquid flow in the sight glass.
 - b. Observing the flow indicator.
 - c. Gauging the car using the gauging device (amount indicates liquid level dropping).
7. Monitor the liquid level in the receiving tank to verify that the tank is not being overfilled.
8. Periodically check for indications that the liquid flow has ceased:
 - a. Check the sight glass periodically for bubbles. Bubbles indicate the last of the liquid is being withdrawn.
 - b. Observe the flow indicator.
 - c. Watch for buckling of the liquid hose.

Shut down the liquid transfer operation

1. When product ceases to flow, shut down the transfer operation:
 - a. Turn liquid pump off.
 - b. Allow pressure to equalize.
 - c. Close the vapor valve on the receiving tank.
 - d. Close the vapor valve on the damaged tank car.
 - e. Close the liquid valve on the damaged tank car.
 - f. Close the liquid valve on the receiving tank.

2. Purge hoses and/or piping:

- a. Purge vapor hose:

- Adjust the regulator on nitrogen cylinder 15 psi above the pressure in the damaged tank car.
- Open the valve on the nitrogen cylinder.
- Open the vapor hose bleeder valve at the receiving tank.
- Open the vapor valve on the damaged tank car.
- After 20 seconds, partially open the vapor hose bleeder valve at the damaged tank.

Note: If the product is flammable, test the discharge with an Explosimeter. When the Explosimeter does not pick up explosive concentrations in the discharge from the bleeder valve, the vapor hose is full of nitrogen.

When the vapor hose is full of nitrogen:

- Close the vapor valve on the damaged tank car.
- Close the vapor hose bleeder valve at the damaged tank car.
- Close the vapor hose bleeder valve at the receiving tank.
- Close the valve on the nitrogen cylinder near the receiving tank.
- Open the bleeder valves to vent the nitrogen from the hose.

Shut down the liquid transfer operation (continued)

b. Purge liquid hose:

- Adjust the regulator on nitrogen cylinder 15 psi higher than the pressure in the receiving tank.
- Open the valve on nitrogen cylinder.
- Open the liquid hose bleeder valve at the damaged tank car.
- Wait 20 seconds, then open the liquid valve on the receiving tank, wait 20 seconds and close the liquid valve on the receiving tank.
- Repeat the process four times to remove as much liquid from the liquid hose as possible.
- After repeating the process four times:
 - Close the liquid valve on the receiving tank:
 - Close the liquid hose bleeder valve at the damaged tank car:
 - Close the valve on the nitrogen cylinder near the damaged tank car:
 - Open the bleeder valves to vent the nitrogen from the hose.

Caution: Some product will remain in the liquid hose after purging, therefore use caution when disassembling and lowering hoses to the ground.

3. Disassemble and clean the transfer equipment.
4. Secure cars (apply plugs in air, liquid, gauging device valves, and/or bottom outlet caps and tighten with a suitable tool).

This page left blank intentionally

Overview

This product-removal method involves the controlled release and burning of a flammable liquefied compressed gas from the outlet of a flare pipe. The vapor flare is used to reduce the pressure or dispose of the residual vapors in a damaged or overloaded tank car.

The vapor flaring method may be used when:

- The product cannot be safely vented to the atmosphere or quickly transferred to a receiving tank;
- The internal pressure of a tank car tank must be reduced as quickly as possible to reduce the chance of violent rupture (*this may serve as an interim measure until arrangements can be made to transfer or otherwise dispose of the contents*);
- There is a need to dispose of residual vapors in a tank car tank after the liquid has been removed; and/or
- There is a need to reduce the pressure in the receiving tank to create a positive pressure differential for a transfer method.

Preferred Conditions

To the extent possible, the following conditions should exist, or be met, before flaring vapors (these conditions are considered optimal, but may not be met in all cases due to local circumstances):

- The tank car tank contains a flammable liquefied compressed gas;
- The tank is not exposed to fire;
- The tank car is in a position that will allow vapor flaring (e.g., excess flow check valves have not seated, or, if seated, tools are available to unseat them);
- The required valves are accessible and operable (or the use of a hot tap is feasible);
- Suitable equipment for flaring vapors is available;
- Personnel experienced in vapor flaring are available;
- Suitable precautions can be taken to protect the tank car tank and the vapor hose from the heat generated by vapor flaring;
- Suitable precautions can be taken to protect people and property in the event of an accidental release during vapor flaring.

Potential Risks

The following risks may be associated with flaring vapors:

- The heat generated by flaring vapors may ignite fires or damage adjacent equipment;
- Failure of the tank, vapor hose, or other flaring equipment could expose people, property, and the environment to the contents of the tank car;
- Products of combustion may be toxic or cause environmental damage;
- The flare may be unintentionally extinguished resulting in an accumulation of vapor which may ignite; and/or
- Auto refrigeration of some products caused by flaring may result in temperatures low enough to cause embrittlement and possible failure of the tank material.

Safety Precautions

The following safety precautions should be taken when flaring vapors:

- Secure the car(s) from movement. Tighten the hand brakes and chock the wheels, if necessary.
- Place blue flags, if required.
- Ground the damaged tank car.
- Limit site access to required personnel only.
- Perform vapor flaring with only qualified personnel.
- Check to see that the flaring equipment is clean and appropriate for the product being flared.
- Clean and wrap all pipe threads with pipe joint tape before making connections.
- Clean all hose connections before joining, replacing “O” rings and gaskets, if necessary.
- Use an emergency shut-off system (“emergency shut-off” and “back check” valves) to either automatically or manually shut down the transfer in case of an unintentional release caused by a hose break or other malfunction. *The use of the emergency shut-off system does not require personnel on the tank during the transfer.*

The emergency shut-off valve is designed to be operated from a remote location. The valve may incorporate a back flow check valve and/or fusible plug or other heat activated device that will automatically close the valve in the event of fire.

The back check valve is designed to prevent backflow in a hose. In the case of a small pressure differential, it may allow some leakage in the reverse direction.

Note: NFPA 58, Standard for Storage and Handling of Liquefied Petroleum Gas, requires emergency shut-off equipment when loading and unloading tank cars of flammable gases.

- Use the appropriate personal protective equipment.
- Monitor the site with the appropriate vapor monitoring equipment.

Safety Precautions *(continued)*

- If the product is flammable or combustible, appropriate fire fighting equipment and extinguishing agents should be available.
- If the product is flammable or combustible, control ignition sources within 15 feet of operations:
 - Do not permit smoking on site.
 - Eliminate or shut off any electrical equipment that is not intrinsically safe.
 - Shut off any internal-combustion engines that are not intrinsically safe.
- All other work should be suspended during vapor flaring.

Required Equipment

Tools and supplies

Minimum	Desired	
1	1	24" pipe wrench.
1	1	12" adjustable wrench.
1	2	Spanner or "J" wrench or brass hammer (appropriate for couplings on the hoses used).
1	1	1/4" pressure gauges with pressure range suitable for product being transferred.
1	1	Explosimeter.
1	1	Armored thermometer with chain (<i>optional</i>).
1	1	Paint scraper.
1	1	Wire brush.
1	1	Pair pliers.
1	2	Rolls of pipe joint tape.
1	1	Roll of duct tape.
1	2	Spray bottle containing commercial leak detector or a solution of dishwashing soap.
1	2	25' length of rope.
1	1	6' copper grounding rod.
1	1	6'-8' grounding strap with pressure point clamps.
6	6	Fusees.

Required Equipment *(continued)*

Fittings and other flaring equipment

Minimum	Desired	
(1)	(1)	3" to 2" bushing (when cars are equipped with 3" valves).
1	1	Vapor valve outlet assembly [See Figure 8-1].
Sufficient		Lengths of vapor hose or Schedule 80 steel pipe with appropriate connectors to place the flare stack 150' away from the tank car.
Sufficient		"O" rings or gaskets for liquid and vapor hoses.
		Notes:
		<ul style="list-style-type: none"> • <i>Hose material, "O" rings, and fittings must be compatible with the product.</i> • <i>Hoses for liquefied petroleum gas should not be interchanged with hoses used for ammonia.</i>
Sufficient		1/4" nitrogen hose for purging and testing for leaks in vapor hose (including adapters for the bleeder valves on one end and for the nitrogen regulator outlet on the other end). Hose should be able to handle pressures above that found in the tank.
Sufficient		Nitrogen hose for emergency shut-off valves operation (minimum operating pressure of 50 psi).
1	1	Ground control valve.
1	1	Four-way fitting for the nitrogen hose for emergency shut-off valves.
1	1	Control switch for emergency shut-off valves.
1	2	Nitrogen regulator, 0-300 psi.
1	2	Cylinder of nitrogen.
1	1	Flare stack.

Vapor Flaring

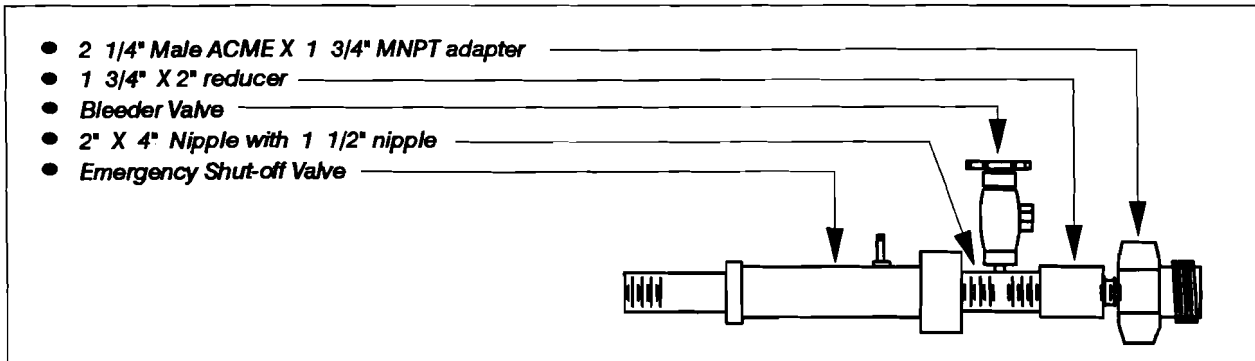

Figure 8-1: Vapor valve outlet assembly for the damaged tank car.

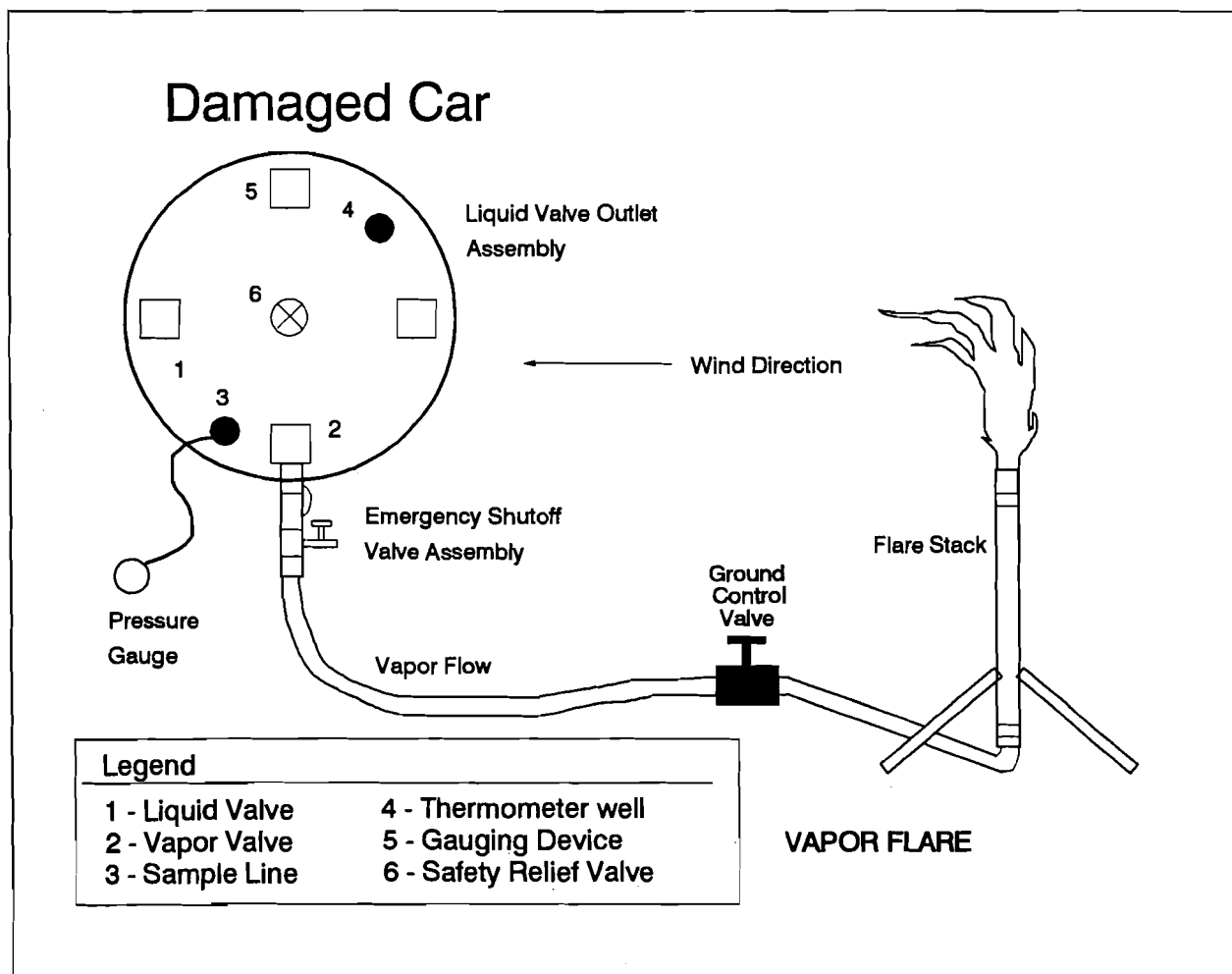

Figure 8-2: Diagram of vapor flaring operation.

Flare Stand

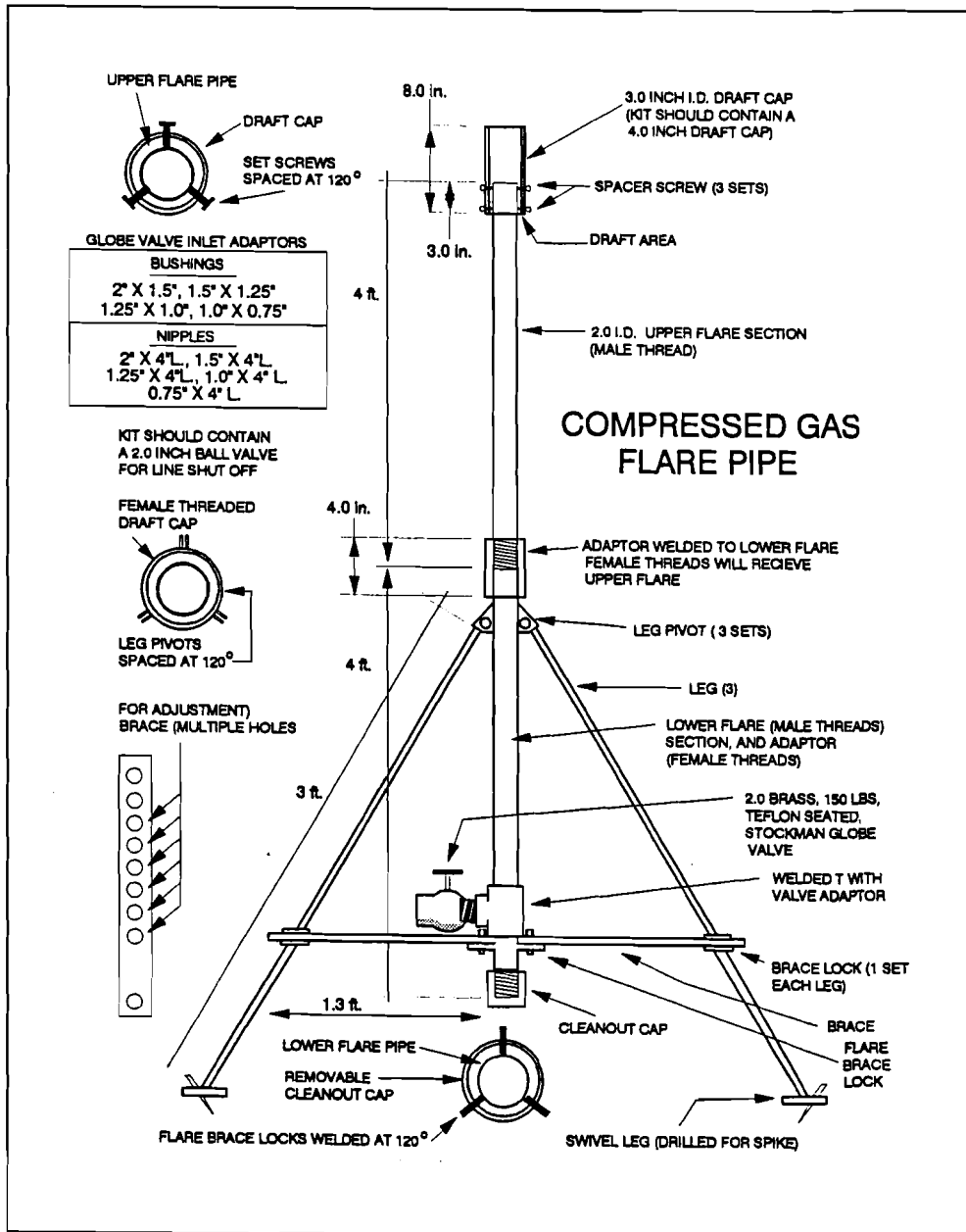

Figure 8-3: Diagram of flare stand.

General Procedures

Plan the vapor flaring operation

1. Determine the capacity of the tank car and the amount of product it contains, then attach a pressure gauge to the sample line or other suitable fitting and determine the internal pressure in the tank car.
2. Select a location for the flare stack (at least 150' upwind of the tank car). *Consider effects of changing wind direction during operation.*
3. Prepare a checklist of all equipment required to perform the flare operation.
4. Prepare a plan for set-up, implementation, and shut-down of the flare operation:
 - a. Diagram the location and orientation of the cars involved.
 - b. Diagram the location and orientation of equipment, gauges, hoses, and connections to be used in the vapor flare.
 - c. Prepare a checklist of the procedures for set-up, implementation, and shut-down of the flare operation.
5. Prepare a site safety plan.
6. Obtain the required equipment for the vapor flare operation.

Set up the vapor flaring operation

1. Hold a safety briefing and discuss items such as:
 - Person in charge.
 - Properties of products.
 - Signals for emergency shut-down.
 - Evacuation routes.
 - Etc.
2. Ground the tank car by attaching one end of a grounding strap to the tank and the other end to a grounding rod that has been driven at least 3' into the ground.
3. Connect the vapor valve outlet assembly to the tank car:
 - a. Clean the male pipe threads and wrap them with pipe joint tape.
Note: When necessary, clean the female threads with a pipe tap.
 - b. Attach the vapor valve outlet assembly (with emergency shut-off valve) to a vapor valve.
 - c. Position the vapor valve outlet assembly with the bleeder valve outlet/inlet in a horizontal position and tighten.
4. Position the flare stack:
 - a. Assemble the flare stand.
 - b. Position the ground control valve 50' from the flare stand toward the damaged tank car.
 - c. Clear burnable materials for at least 30' radius around the flare stack.
5. Attach required hoses and/or piping:
Note: Pipe can be substituted for hose if the damaged tank is stationary on the ground. Because of the possibility of movement, hoses should be used if tanks are on their trucks.

Set up the vapor flaring operation (continued)

Caution: Clean all hoses and piping as necessary to remove any contaminants that may be present.

- a. Check for “O” rings or gaskets in all hoses and replace if missing or damaged.
 - b. Connect vapor hoses from the vapor valve outlet assembly on the damaged tank car to the ground control valve inlet then from the ground control valve outlet to the flare stand.
 - c. Secure the vapor hose with rope to reduce strain on the valve assembly and hose couplings.
 - d. Use spanner or “J” wrench or brass hammer to tighten Acme thread couplings.
6. Test vapor hose and fittings for leaks:
- a. Attach the regulator to the nitrogen cylinder.
 - b. Set nitrogen regulator to 50 psi.
 - c. Test the vapor hose:
 - Attach one end of a nitrogen hose to the bleeder valve on the vapor valve outlet assembly and attach the other end to the regulator on the nitrogen cylinder.
 - Open the valve on the nitrogen cylinder.
 - Open the bleeder valve on the vapor valve outlet assembly.
 - Check the hose connections for leaks.
 - Close the valve on the nitrogen cylinder.
7. Open the ground control valve to drain the nitrogen from vapor line.
- Note: The purpose of draining the vapor hose is to ensure that, upon opening the vapor valve on the damaged tank car, a significant vapor flow velocity is attained before the vapor reaches the end of the vapor hose. This reduces the possibility of a flashback occurring in the vapor hose when the vapors are ignited.*
8. Set up the emergency shut-off system, if used, by connecting hoses and other fittings to the emergency shut-off valve.
 9. Cover any hose within 30 feet of flare stand with soil.

Implement the vapor flaring operation

1. Determine the internal pressure in the damaged tank car again.
2. Activate emergency shut-off system.
3. Attach a fusee to the end of a 5'-6' pole.
4. Ignite the fusee and place it near the opening on the flare stack.
5. Start flow of vapor from damaged tank car:
 - a. Open the vapor valve to the 1/4 to 1/2 open position.
 - b. Attempt to ignite the vapors escaping from the flare stack.

Note: If ignition does not occur immediately, close the ground control valve and repeat step 5.
 - c. After ignition, open the vapor valve fully.
6. Control the vapor flaring rate with the ground control valve.

Shut down the vapor flaring operation

1. After the flare is extinguished, close the vapor valve on the damaged tank car.
2. Purge hoses and/or piping:
 - a. Adjust the regulator on nitrogen cylinder 15 psi higher than the pressure in the damaged tank car.
 - b. Open the valve on the nitrogen cylinder.
 - c. Open the vapor hose bleeder valve.

Note: If the product is flammable, test the discharge with an Explosimeter.
 - d. Close ground control valve.
 - e. Close the valve on the nitrogen cylinder.
3. Disassemble and clean the vapor flare equipment.

Note: The flare stand will be hot. Allow sufficient time for it to cool before disassembly.
4. Secure cars (apply plugs in vapor, liquid, and sample line and gauging device valves and tighten with a suitable tool).

Overview

This product-removal method involves the controlled release and burning of liquefied flammable gases and flammable and combustible liquids from the outlet of a flare pipe. A pit is used to contain any product not completely burned.

The liquid flaring method may be used when:

- Conditions require disposal of the product on site due to contamination, polymerization, leakage, or tank damage;
- It is unsafe or impractical to rerail the car for movement; and/or
- The product cannot be safely vented to the atmosphere or quickly transferred to a receiving tank.

Preferred Conditions

To the extent possible, the following conditions should exist, or be met, before flaring liquids (these conditions are considered optimal, but may not be met in all cases due to local circumstances):

- The tank car tank contains a flammable liquid or a combustible liquid;
- A delayed rupture is not likely;
- The tank is not exposed to fire;
- The tank car is in a position that will allow liquid flaring (e.g., excess flow check valves have not seated, or, if seated, tools are available to unseat them);
- The required valves are accessible and operable (or the use of a hot tap is feasible);
- Equipment suitable for liquid flaring is available;
- Personnel experienced in liquid flaring are available;
- Suitable precautions can be taken to protect the tank car tank and the liquid hose from the heat generated by liquid flaring; and
- Suitable precautions can be taken to protect people and property in the event of an accidental release during liquid flaring.

Potential Risks

The following risks may be associated with liquid flaring:

- The fire associated with the liquid flare may be difficult to control;
- The heat generated by flaring liquids may ignite fires or damage adjacent equipment;
- Failure of the tank or liquid flaring equipment could expose people, property, and the environment to the contents of the damaged tank car;
- Products of combustion may be toxic or cause environmental damage;
- The flare may be unintentionally extinguished, resulting in an accumulation of vapor that may ignite violently; and/or
- Auto refrigeration of some products caused by flaring may result in temperatures low enough to cause embrittlement and possible failure of the tank material.

Safety Precautions

The following safety precautions should be taken when flaring liquids:

- Secure the car(s) from movement. Tighten the hand brakes and chock the wheels, if necessary.
- Place blue flags, if required.
- Ground the tank car,

Note: Liquid flaring is considered an open system. NFPA 77 requires grounding and bonding when loading and unloading tank cars through open systems.

- Limit site access to required personnel only.
- Perform transfer using only qualified personnel.
- Check to see that the transfer equipment is clean and appropriate for the product being flared.
- Clean and wrap all pipe threads with pipe joint tape before making connections.
- Clean all hose connections before joining, replacing “O” rings and gaskets, if necessary.
- Use an emergency shut-off system (“emergency shut-off” and “back check” valves) to either automatically or manually shut down the operation in case of an unintentional release caused by a hose break or other malfunction. *The use of the emergency shut-off system does not require personnel on the tank during the transfer.*

The emergency shut-off valve is designed to be operated from a remote location. The valve may incorporate a back flow check valve and/or fusible plug or other heat activated device that will automatically close the valve in the event of fire.

The back check valve is designed to prevent backflow in a hose. In the case of a small pressure differential, it may allow some leakage in the reverse direction.

Note: NFPA 58, Standard for Storage and Handling of Liquefied Petroleum Gas, requires emergency shut-off equipment when loading and unloading tank cars of flammable gases.

- Use the appropriate personal protective equipment.
- Monitor the site with the appropriate vapor monitoring equipment.

Safety Precautions *(continued)*

- If the product is flammable or combustible, appropriate fire fighting equipment and extinguishing agents should be available.
- If the product is flammable or combustible, control ignition sources within 15 feet of operations:
 - Do not permit smoking on site.
 - Eliminate or shut off any electrical equipment that is not intrinsically safe.
 - Shut off any internal-combustion engines that are not intrinsically safe.
- Suspend all other work during liquid flaring.

Required Equipment

Tools and supplies

Minimum	Desired	
1	1	24" pipe wrench.
1	1	12" adjustable wrench.
1	2	Spanner or "J" wrench or brass hammer (appropriate for couplings on the hoses used).
1	1	1/4" pressure gauges with pressure range suitable for product being transferred.
1	1	Explosimeter.
1	1	Armored thermometer with chain (<i>optional</i>).
1	1	Paint scraper.
1	1	Wire brush.
1	1	Pair pliers.
1	2	Rolls of pipe joint tape.
1	1	Roll of duct tape.
1	2	Spray bottle containing commercial leak detector or a solution of dishwashing soap.
1	2	25' length of rope.
1	1	6' copper grounding rod.
1	1	6'-8' long grounding strap with pressure point clamps.
6	6	Fusees.

Required Equipment *(continued)*

Fittings and other liquid flaring equipment

Minimum	Desired	
(1)	(1)	3" to 2" bushing (when cars are equipped with 3" valves).
1	1	Liquid valve outlet assembly [See Figure 9-1].
Sufficient		"O" rings or gaskets for liquid and vapor hoses.
Sufficient		<i>Notes: Hose material, "O" rings, and fittings must be compatible with the product.</i>
1	1	Nitrogen hose for emergency shut-off system (minimum operating pressure of 50 psi).
1	1	Ground control valve.
1	1	Four-way fitting for the nitrogen hose for emergency shut-off system.
1	1	Pushbutton for emergency shut-off system.
1	2	Nitrogen regulator, 0-300 psi.
1	2	Cylinder of nitrogen.
1	1	21' horizontal flare pipe.
1	1	Treatment system for vapors, if product is toxic.

Liquid Flaring

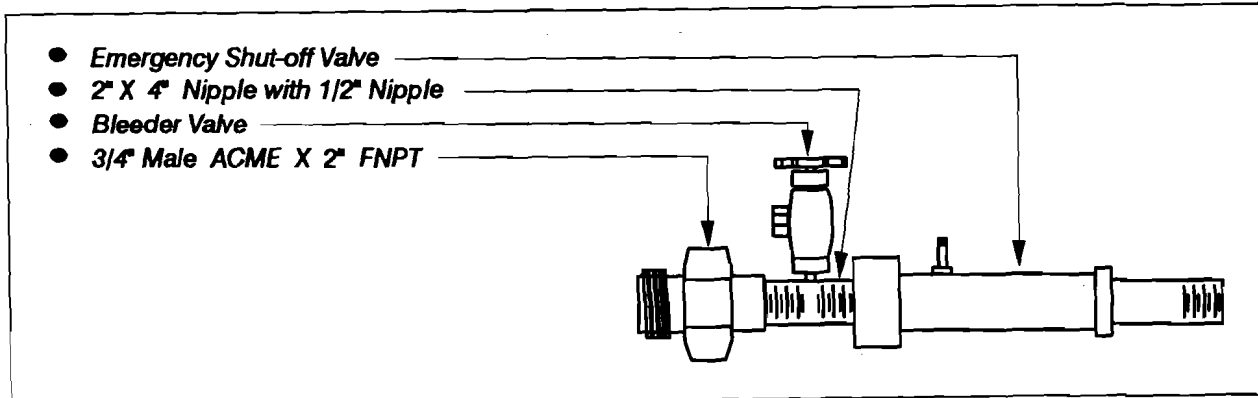

Figure 9-1: Liquid valve outlet assembly for the tank car.

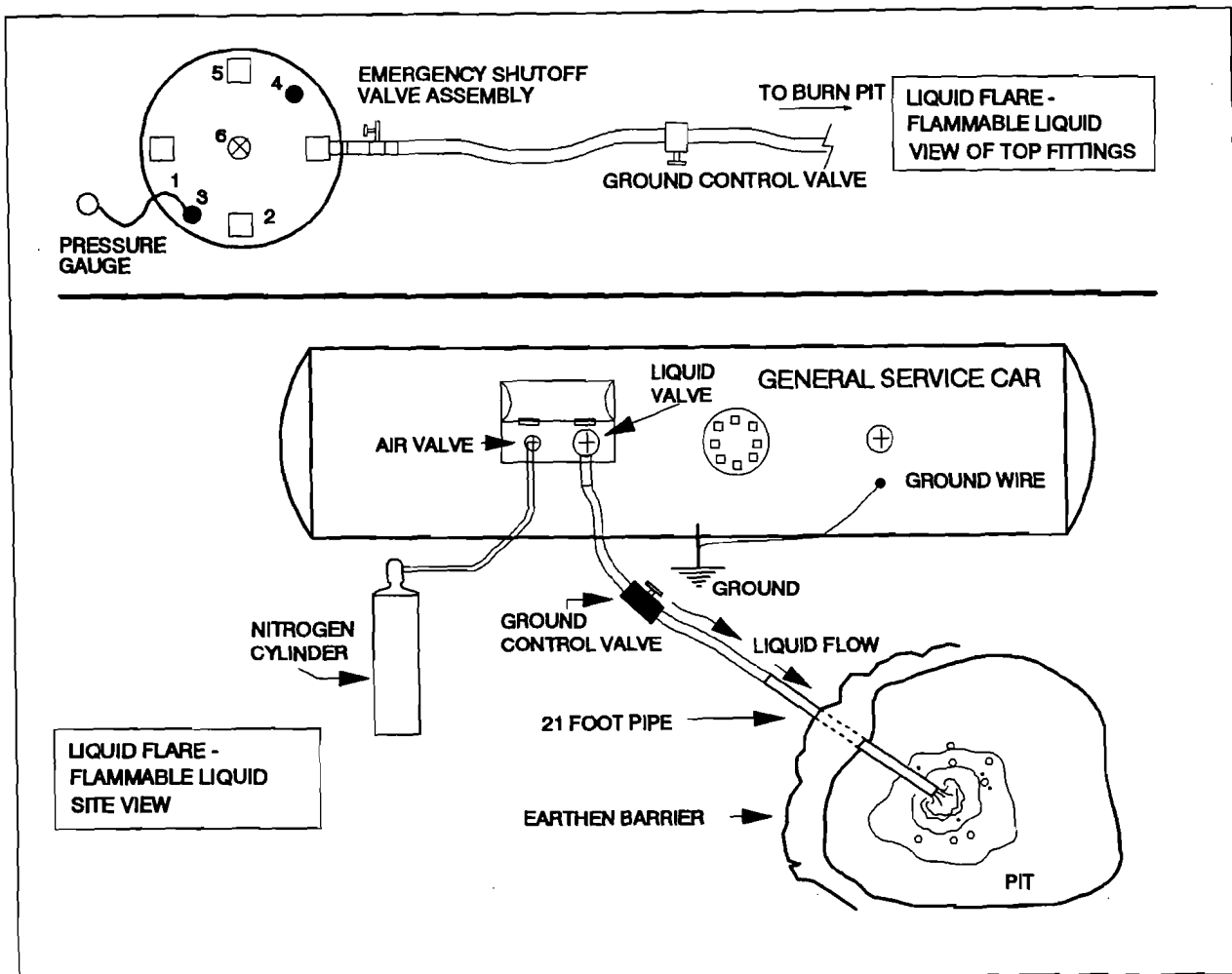

Figure 9-2: Diagram of liquid flaring operation.

General Procedures

Plan the liquid flaring operation

1. Determine the capacity of the damaged tank car and the amount of product it contains, then attach a pressure gauge to the sample line or other suitable fitting and determine the internal pressure in the car.
2. Select a location for the flare pipe (at least 150' upwind of the damaged tank car).
3. Prepare a checklist of all equipment required to perform the liquid flare operation.
4. Prepare a plan for set-up, implementation, and shut-down of the liquid flare operation:
 - a. Diagram the location and orientation of the cars involved.
 - b. Diagram the location and orientation of equipment, gauges, hoses, and connections to be used.
 - c. Prepare a checklist of the procedures for set-up, implementation, and shut-down.
5. Prepare a site safety plan.
6. Obtain the required equipment for the liquid flare.

Set up the liquid flaring operation

1. Hold a safety briefing and discuss items such as:
 - Person in charge.
 - Properties of products.
 - Signals for emergency shut-down.
 - Evacuation routes.
 - Etc.
2. Ground the tank car by attaching one end of a grounding strap to the tank and the other end to a grounding rod that has been driven at least 3' into the ground.
3. Prepare a flare area by digging a pit (20' radius, 2' deep) at least 150' from the damaged tank car. Place the excavated soil to form a barrier between the pit and the damaged tank car.
4. Position the flare pipe—clearing burnable materials for at least 100' from the pit.

Set up the liquid flaring operation (continued)

5. Connect the liquid valve outlet assembly to the damaged tank car:
 - a. Clean the male pipe threads and wrap them with pipe joint tape.
Note: When necessary, clean the female threads with a pipe tap.
 - b. Attach the liquid valve outlet assembly (with emergency shut-off valve) to a liquid valve on the tank car, and
 - c. Position the liquid valve outlet assembly with the bleeder valve outlet/inlet in a horizontal position and tighten.

6. Attach required liquid hoses and/or piping:
Note: Pipe can be substituted for hose if the damaged tank is stationary on the ground. Because of the possibility of movement, hoses should be used if tanks are on their trucks.
Caution: Clean all hoses and piping as necessary to remove any contaminants that may be present.
 - a. Check for "O" rings or gaskets in all hoses and replace if missing or damaged.
 - b. Attach liquid hoses from the liquid valve outlet assembly on the damaged tank car to the ground control valve, then from the ground control valve to the flare pipe. Place the ground control valve near the damaged tank car.
 - c. Secure the liquid hose with rope to reduce strain on the valve assembly and hose couplings.
 - d. Use spanner or "J" wrench or brass hammer to tighten Acme thread couplings.

7. Test liquid hose and fittings for leaks:
 - a. Attach the regulator to the nitrogen cylinder.
 - b. Set nitrogen regulator to 50 psi.
 - c. Attach one end of a nitrogen hose to the bleeder valve on the liquid valve outlet assembly and attach the other end to the regulator on the nitrogen cylinder.
 - d. Open the valve on the nitrogen cylinder.
 - e. Open the bleeder valve on the liquid valve outlet assembly.
 - f. Check the liquid hose connections for leaks; correct as necessary.
 - g. Close the valve on the nitrogen cylinder.

General Procedures *(continued)*

Set up the liquid flaring operation (continued)

- h. Open the ground control valve to drain the nitrogen from liquid line.

Note: The purpose of draining the liquid hose is to ensure that, upon opening the liquid valve on the damaged tank car, a significant liquid flow velocity is attained before the liquid reaches the end of the liquid hose. This reduces the possibility of a flashback occurring in the liquid hose when the liquid is ignited.

8. Set up the emergency shut-off system, if used, by connecting hoses and other fittings to the emergency shut-off valve.
9. Cover any hose from the flare pipe to the ground control valve with soil to protect it from the radiant heat of the flare.

Implement the liquid flaring operation

1. Determine the internal pressure in the damaged tank car again.
2. If the contents are near or below their boiling temperature, pressurize the damaged tank car with nitrogen.
3. Activate emergency shut-off system.
4. Place 4-6 burning fusees in the pit near the outlet of the flare pipe and light the fusees.
5. Start flow of liquid from damaged tank car by:
 - a. Opening the liquid valve to the full open position.
 - b. Opening the ground control valve to the 1/4 open position until ignition occurs.

Note: If ignition does not occur immediately, close the ground control valve and repeat step 5.
 - c. After ignition, open the ground control valve to the full open position.
6. Control the liquid flaring rate with the ground control valve.

Shut down the liquid flaring operation

1. After the flare is extinguished, close the liquid valve on the damaged tank car.
2. Cool surfaces before disassembling liquid flare equipment.
3. Purge hoses and/or piping:
 - a. Adjust the regulator on nitrogen cylinder 15 psi higher than the pressure in the damaged tank car.
 - b. Open the valve on the nitrogen cylinder.
 - c. Open the liquid hose bleeder valve.

Note: Since the product is flammable, test the discharge with an Explosimeter.
 - d. Close the liquid hose bleeder valve.
 - e. Close ground control valve.
 - f. Close the valve on the nitrogen cylinder.
4. Disassemble and clean the liquid flare equipment.
5. Secure cars (apply plugs in vapor, liquid, and sample line and gauging device valves and tighten with a suitable tool).

This page left blank intentionally

Overview

This product-removal method involves the release of the vapors of a nonflammable gas to the atmosphere. If the product is a toxic material, its vapors must be routed through a treatment system (scrubber) to detoxify the product prior to release to the atmosphere.

This product-removal method may be used when:

- The internal pressure of a tank car tank must be reduced to minimize the chance of violent rupture;
- It is necessary to reduce pressure in the receiving tank to create a positive pressure differential for transfer; and/or
- The tank car tank has been damaged to the extent that it cannot safely be rerailed and moved to an appropriate unloading point.

Preferred Conditions

To the extent possible, the following conditions should exist, or be met, before performing venting (these conditions are considered optimal, but may not be met in all cases due to local circumstances):

- The tank car contains a nonflammable gas;
- The tank car is in a position that will allow venting (e.g., excess flow check valves have not seated, or, if seated, tools are available to unseat them);
- The required valves are accessible and operable (or the use of a hot tap is feasible);
- Suitable venting equipment is available (*see Required Equipment listed on page 136*);
- A suitable treatment system is available to render the product safe for release into the atmosphere;
- Experienced venting personnel are available; and
- Suitable precautions can be taken to protect people, the environment, and property in the event of an accidental release during the venting.

Potential Risks

The following risks may be associated with venting:

- Failure of the tank or venting equipment could expose people, property, and the environment to the contents of the damaged tank car; and/or
- Auto refrigeration of some products caused by venting operation may result in temperatures low enough to cause embrittlement and possible failure of the tank material.

Safety Precautions

The following safety precautions should be taken when performing venting:

- Secure the car(s) from movement. Tighten the hand brakes and chock the wheels, if necessary.
- Place blue flags, if required.
- Limit site access to required personnel only.
- Perform venting using only qualified personnel.
- Check to see that the venting equipment is clean and appropriate for the product being vented.
- Clean and wrap all pipe threads with pipe joint tape before making connections.
- Clean all hose connections before joining, replacing “O” rings and gaskets, if necessary.
- Use an emergency shut-off system to either automatically or manually shut down the transfer in case of an unintentional release caused by a hose break or other malfunction. *The use of the emergency shut-off system does not require personnel on the tank during venting.*

The emergency shut-off valve is designed to be operated from a remote location. The valve may incorporate a back flow check valve and/or fusible plug or other heat activated device that will automatically close the valve in the event of fire.

- Use the appropriate personal protective equipment.
- Monitor the site with the appropriate vapor monitoring equipment, and adjust the venting rate as required.

Required Equipment

Tools and supplies

Minimum	Desired	
1	1	24" pipe wrench.
1	1	12" adjustable wrench.
1	2	Spanner or "J" wrench or brass hammer (appropriate for couplings on the hoses used).
1	1	Pair of water pump pliers.
2	2	1/4" pressure gauges with pressure range suitable for product being transferred.
1	1	Paint scraper.
1	1	Wire brush.
1	2	Rolls of pipe joint tape.
1	1	Roll of duct tape.
1	2	Spray bottle containing commercial leak detector or a solution of dishwashing soap.
2	2	25' length of rope.
1	1	Spool of baling wire.

Required Equipment *(continued)*

Fittings, hose, and venting equipment

Minimum	Desired	
(1)	(1)	3" to 2" bushing (when cars are equipped with 3" valves).
1	1	Vapor valve outlet assembly [See Figure 10-1].
Sufficient		21' length of Schedule 80 steel pipe with appropriate connectors.
Sufficient		"O" rings or gaskets for liquid and vapor hoses.
		Notes:
		<ul style="list-style-type: none"> • <i>Hose material, "O" rings, and fittings must be compatible with the product.</i> • <i>Hoses for liquefied petroleum gas should not be interchanged with hoses used for anhydrous ammonia.</i>
Sufficient		Nitrogen hose for emergency shut-off system (minimum operating pressure of 50 psi).
1	1	Four-way fitting for the nitrogen hose for emergency shut-off system.
1	1	Control switch for emergency shut-off system.
1	2	Nitrogen regulators, 0-300 psi.
1	1	Treatment system for vapors.

Venting

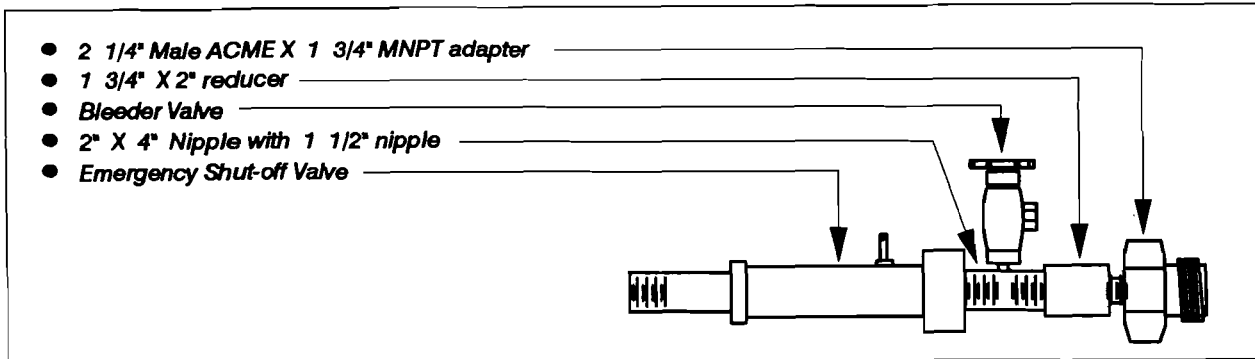

Figure 10-1: Vapor valve outlet assembly for the damaged tank car.

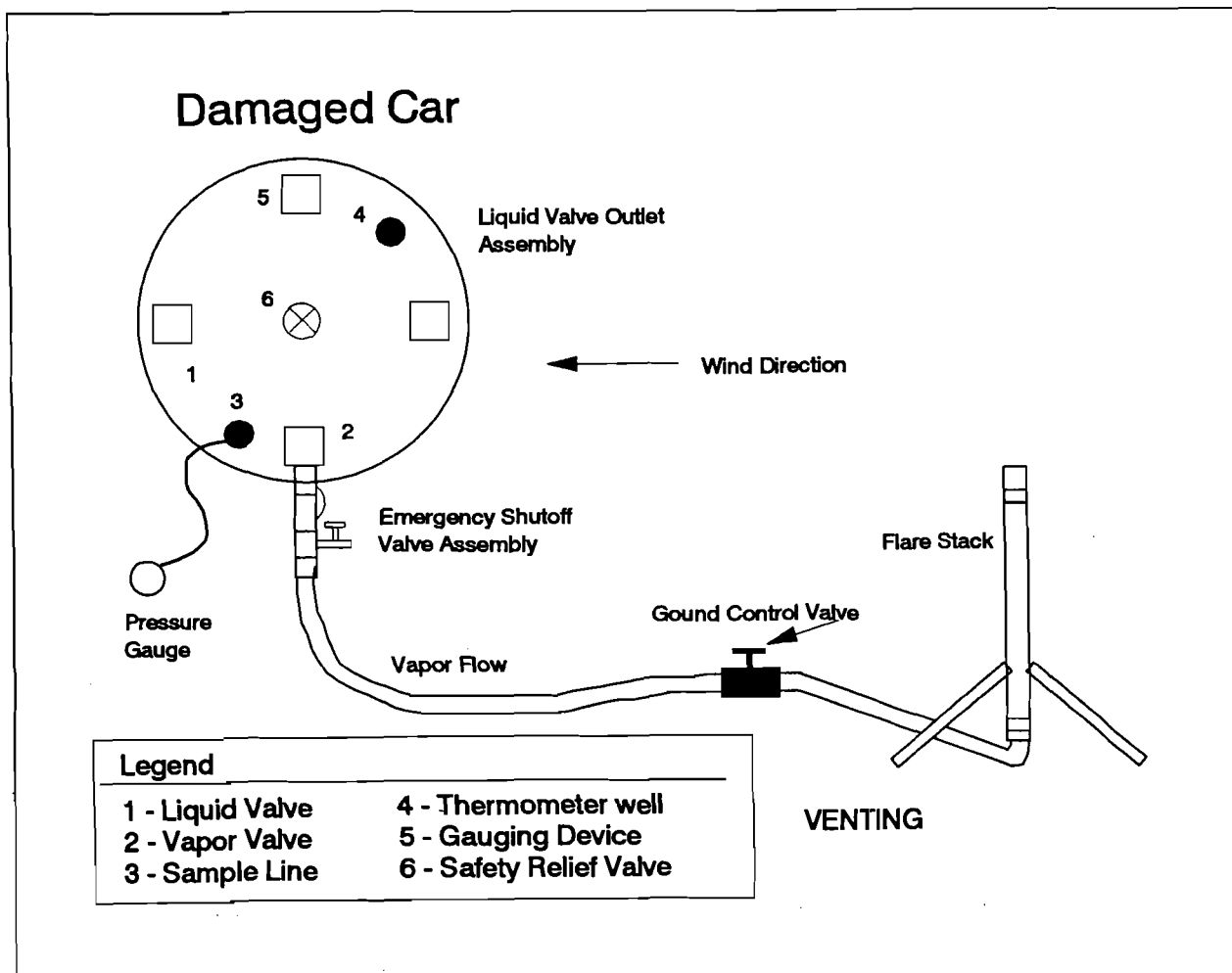

Figure 10-2: Diagram of venting operation.

General Procedures

Plan the venting operation

1. Prepare a checklist of all equipment required to perform the venting operation.
2. Prepare a plan for set-up, implementation, and shut-down of the venting operation:
 - a. Diagram the location and orientation of the cars involved.
 - b. Diagram the location and orientation of equipment, gauges, hoses, and connections to be used in the operation.
 - c. Prepare a checklist of the procedures for set-up, implementation, and shut-down of the venting operation.
3. Prepare a site safety plan.
4. Obtain the required venting equipment.

Set up the venting operation

1. Hold a safety briefing and discuss items such as:
 - Person in charge.
 - Properties of products.
 - Signals for emergency shut-down.
 - Evacuation routes.
 - Etc.
2. Connect fittings to damaged tank car:
 - a. Clean the male pipe threads and wrap them with pipe joint tape.

Note: When necessary, clean the female threads with a pipe tap.
 - b. Attach the vapor valve outlet assembly (with emergency shut-off valve) to a vapor valve.
 - *Optional:* If used, attach a 90-degree elbow to the vapor valve outlet assembly and tighten with the open end pointed with the wind.

Set up the venting operation (continued)

3. Attach required hoses and/or piping:
 - a. Check for "O" rings or gaskets in all hoses and replace if missing or damaged.
 - b. Attach vapor hose to the tank car:
 - Run vapor hose from the vapor valve outlet assembly on the damaged tank car into the vent pipe or scrubbing equipment.
 - c. Secure the hose with ropes to reduce strain on the valve assemblies and hose couplings.
 - d. Use spanner or "J" wrench or brass hammer to tighten Acme thread couplings.
4. If venting to scrubbing equipment, test the hose and fittings for leaks:
 - a. Attach the regulator to the nitrogen cylinder.
 - b. Set nitrogen regulator to 50 psi.
 - c. Close all bleeder valves.
 - d. Test for leaks:
 - Attach one end of a nitrogen hose to the vapor hose bleeder valve at the damaged tank and attach the other end of the hose to the regulator on the nitrogen cylinder.
 - Open the valve on the nitrogen cylinder.
 - Open the vapor hose bleeder valve at the damaged tank car.
 - Test the discharge from the vapor hose bleeder valve at the damaged tank car with an oxygen meter. *When the oxygen level falls dramatically, the vapor hose is full of nitrogen.*
 - When the vapor hose is full of nitrogen, close the vapor hose bleeder valve at the damaged tank car, and check the hose for leaks. Correct leaks as necessary.
 - Close the valve on the nitrogen cylinder.
5. Set up the emergency shut-off system, if used, by connecting hoses and other fittings to the emergency shut-off valve.

Implement the venting operation

1. Activate emergency shut-off system.
2. Open vapor valve on damaged tank car to start flow of product.
3. Monitor airborne concentrations of product and adjust venting as required.
4. Monitor the pressure in the damaged tank car; shut down when pressure is reduced to a desirable level.

Shut down the venting operation

1. Close the vapor valve on the damaged tank car.
2. Purge vapor hose:
 - a. Adjust the regulator on nitrogen cylinder 15 psi higher than the pressure in the damaged tank car.
 - b. Open the valve on the nitrogen cylinder.
 - d. Open the vapor hose bleeder valve on the damaged tank car.
 - e. After 20 seconds, partially open the vapor valve bleeder valve at the damaged tank.
 - g. When the vapor hose is full of nitrogen, close the vapor hose bleeder valve at the damaged tank car.
 - h. Close the vapor hose bleeder valve at the scrubbing equipment.
 - i. Close the valve on the nitrogen cylinder near the receiving tank, and
 - j. Open the bleeder valves to vent the nitrogen from the hose.
3. Disassemble and clean the transfer equipment.
4. Secure car (apply plugs in vapor, liquid, sample line, and gauging device valves and tighten with a suitable tool).

This page left blank intentionally

Overview

This product-removal method involves the placement of explosive charges to cut a hole (or holes) in a tank car tank, allowing the contents to flow into a pit for burn-off.

The vent and burn method may be used when:

- The tank car tank has been exposed to fire resulting in elevated pressure within the tank and possible tank damage;
- Conditions do not allow the safe transfer, venting, or flaring of the tank car;
- Site conditions prevent rerailing the damaged tank car (e.g., the terrain does not permit use of cranes or other rerailing equipment);
- Damage to leaking valves and fittings cannot be repaired; or
- The tank car tank has been damaged to the extent that it cannot be safely rerailed and moved to an appropriate unloading point.

Preferred Conditions

To the extent possible, the following conditions should exist, or be met, before using the vent and burn method (these conditions are considered optimal, but may not be met in all cases due to local circumstances):

- The product involved is a flammable gas, a flammable liquid or a combustible liquid;
- Other cars containing hazardous products will not be adversely affected by the operation;
- Suitable vent and burn equipment is available (*see Required Equipment listed on page 146*);
- Personnel experienced in the vent and burn method are available; and
- Suitable precautions can be taken to protect people and property in the event of an accidental release during the transfer.

Inherent Risks

The following risks are associated with the vent and burn method:

- Due to the possibility of detonation and other hazards, this method should not be attempted with some products (e.g., ethylene oxide);
- Use of improper explosive charges may result in failure of the tank;
- Failure of the vent and burn method could result in a violent rupture of the tank with injury to response personnel, exposure of the local population to the product, property damage, and damage to the environment;
- If multiple charges are required, the first charge to explode may displace the other charges from their proper positions; and/or
- Once the tank is breached, there is no control of the flow of contents.

The use of the vent and burn method is considered the last viable option for product removal because of its inherent hazards.

Safety Precautions

The following safety precautions should be taken when performing the vent and burn method:

- Limit site access to required personnel only.
- Use the appropriate personal protective equipment.
- Monitor the site with the appropriate vapor monitoring equipment.
- Evacuate on the basis of possible violent rupture or toxic cloud migration.
- Expert selection and placement of explosive charges is mandatory.
- Contact FAA to impose air traffic restrictions over the site.
- Ensure that tight coordination and liaison exists between all parties.
- If product is flammable or combustible, appropriate fire fighting equipment and extinguishing agents should be available (have standing by at the edge of the evacuation zone).
- Control ignition sources:
 - Do not permit smoking on site.
 - Eliminate or shut off any electrical equipment that is not intrinsically safe.
 - Shut off any internal-combustion engines that are not intrinsically safe.

Required Equipment

Tools and supplies

- Explosimeter.
- Appropriate explosive charges.
- Fusees.
- Incendiary grenade with provision for remote operation.
- Excavation equipment.

Vent and Burn

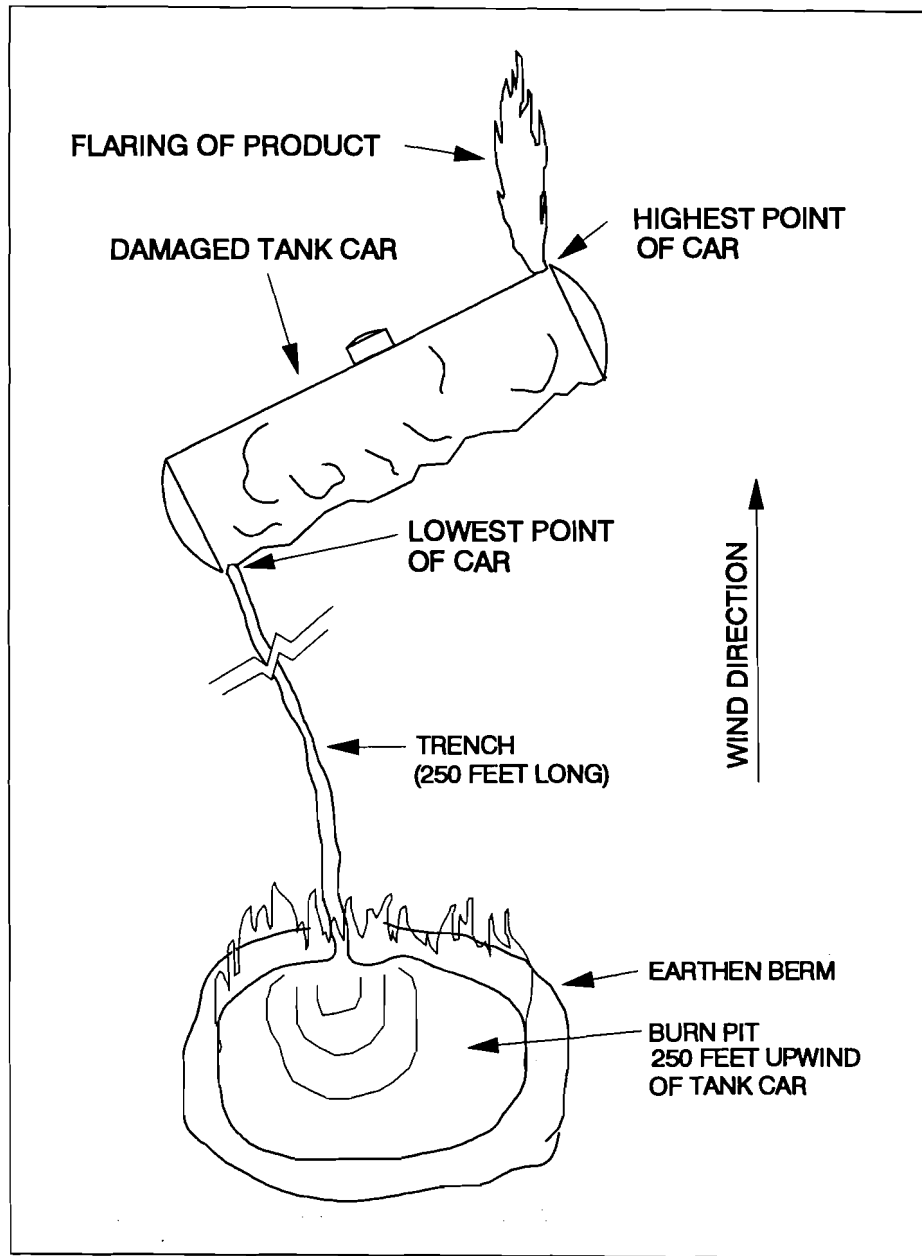

Figure 11-1: Diagram of vent and burn operation.

General Procedures

Plan the vent and burn operation

1. Determine the capacity of the damaged tank car and the amount of product it contains.
2. Select a location for the burn pit (at least 250' upwind of the damaged tank car).
3. Prepare a checklist of all equipment required to perform the vent and burn operation (*see the Required Equipment listed on page 146*).
4. Prepare a plan for set-up, implementation, and shut-down of the vent and burn operation.
5. Prepare a site safety plan.
6. Obtain the required vent and burn equipment.

Set up the vent and burn operation

1. Hold a safety briefing and discuss items such as:
 - Person in charge.
 - Properties of products.
 - Signals for emergency shut-down.
 - Evacuation routes.
 - Etc.
2. Locate an explosives expert experienced in the vent and burn operation. If possible, have the explosives expert try a shot on an empty tank car with the same type and thickness of metal before attempting the operation on the loaded car.
3. Excavate a trench from the lowest point on the damaged tank car to a pit large enough to contain the entire contents of the car.
4. Clear burnable materials for at least 100' around the pit (or have fire suppression equipment on standby).

Implement the vent and burn operation

1. Place explosives charges at the highest and lowest points on the damaged tank car.
2. Place four to six lighted fusees near the mouth of the burn pit, and place a remotely operated incendiary grenade in the bottom of the pit.
3. Detonate the charge at the highest point on the tank car.
4. After pressure has been substantially reduced in the tank (as indicated by the sound of reduced venting or reduction of flame), detonate the charge at the lowest point on the tank car.
5. If the fusees do not immediately ignite the product flowing into the pit, detonate the remotely operated incendiary grenade.

Shut down the vent and burn operation

1. After the fire in the pit has burned itself out, examine the damaged tank car to ensure that no product remains in the tank.
2. Take appropriate actions to purge any remaining vapor in the damaged tank car.
3. Ensure that the damaged tank car is safe to move by monitoring with an Explosimeter.

This page left blank intentionally

Overview

The hot tap is a technique used to gain access to a tank for the purpose of product removal. Hot tapping involves the welding of a threaded nozzle to the exterior of a tank. A valve is attached to the threaded nozzle and a hole is drilled through the tank with a specially designed drilling machine. The drilling machine is equipped with seals that prevent loss of product during the drilling operation. Hoses are attached to the valve outlet and the contents are removed from the tank using one of the product removal methods described in Sections 2 through 11.

The hot tap method may be used when:

- The tank car tank has been damaged to the extent that it cannot be safely rerailed and moved to an appropriate unloading point; and
- The existing valves on the tank car are either damaged beyond repair or inaccessible because of car position.

Note: Because of the possibility of burn-through or explosive decompression, a hot tap should not be used under any circumstances on tank car tanks containing the following products:

- Bromine;
- Chlorine;
- Cryogenic liquids;
- Elemental sulfur;
- Ethylene;
- Ethylene oxide;
- Hydrocarbons in stainless steel tanks;
- Hydrochloric acid;
- Nitric acid;
- Propylene oxide;
- Sulfuric acid.

Note: Contact the manufacturer of the tank and the product before the hot tap method is used.

Preferred Conditions

To the extent possible, the following conditions should exist, or be met, before hot tapping (these conditions are considered optimal, but may not be met in all cases due to local circumstances):

- The tank is not exposed to fire;
- The area is free of flammable vapors;
- The contents must be able to withstand the heating that occurs when a nozzle is welded to the tank without undergoing chemical reactions that could rupture the tank;
- An undamaged portion of the tank *that is in contact with the liquid phase of the product* is in a position where the response personnel can perform a hot tap;
- A welder certified by the American Society of Mechanical Engineers (ASME) is available to weld the threaded nozzle onto the tank;

Note: As a minimum, the welder should be certified in the 6G position.

- Suitable hot tap equipment is available (*see Required Equipment listed on page 154*);
- Personnel experienced in hot tap procedures are available; and
- Suitable precautions can be taken to protect people and property in the event of an accidental release during the transfer.

Potential Risks

The following risks may be associated with a hot tap:

- Failure of the installed valve or nozzle (including the weld) could expose people, property, and the environment to the contents of the damaged tank car;
- A chemical reaction initiated by the welding process could cause the tank to release of its contents;
- The tensile strength of the tank metal could be reduced by mistakenly performing the hot tap in the vapor space of the tank (due to an inadequate heat sink);
- Contents of the tank car could be lost when the drilling machine is removed due to metal shavings from the tapping operation being lodged in the control valve.

Safety Precautions

The following safety precautions should be taken when hot-tapping tank cars:

- Secure the car(s) from movement. Tighten the hand brakes and chock the wheels, if necessary.
- Place blue flags, if required.
- Limit site access to required personnel only.
- Perform hot tap using only qualified/experienced personnel.
- Use welder who is ASME-certified in the 6G position.
- Do not hot tap the following products: bromine, chlorine, cryogenic liquids, elemental sulfur, ethylene, ethylene oxide, hydrocarbons in stainless steel tanks, hydrochloric acid, nitric acid, propylene oxide, or sulfuric acid.
- Check to see that the hot tap equipment is clean and appropriate for the product being transferred.
- Clean and coat all pipe threads with pipe dope before making connections.
- Pressure test the auxiliary nozzle for leaks with nitrogen before starting drilling operation.
- Use the appropriate personal protective equipment.
- Monitor the site with appropriate vapor monitoring equipment.
- If product is flammable or combustible, appropriate fire fighting equipment and extinguishing agents should be available.
- If product is flammable or combustible, control ignition sources within 15' of operations:
 - Do not permit smoking on site.
 - Eliminate or shut off any electrical equipment that is not intrinsically safe.
 - Shut off any internal-combustion engines that are not intrinsically safe.
- Have welder make a minimum of three practice welds in the same position and on the same thickness of plate as he or she will actually be working on.

Required Equipment

Tools and supplies

Number	
1	Mechanical shear, nibbler, or cutting torch to cut through jacket if tank car tank is jacketed.
1	Scrapers, wire brushes, and sandpaper to remove sprayed-on thermal protection, paint, rust, or scale from outside of tank surface.
1	Hot tap machine (drilling machine) (<i>see Figure 12-1</i>).
3	6,000 psi couplings with threaded ends, cut in half to yield six half couplings.
2	2" diameter pipe nipples (6" long, Schedule 80 with NPT on both ends).
2	2" ball valve, stainless steel.
1	Tube pipe dope.
1	Spray bottle containing commercial leak detector or a solution of dishwashing soap.
1	1/4" pressure gauges with pressure range suitable for the contents of the tank car tank.
1	Cylinder nitrogen (or compatible inert gas).
1	Nitrogen regulator, 0-500 psi.
Sufficient	Nitrogen hose for pressure test.

Hot Tap

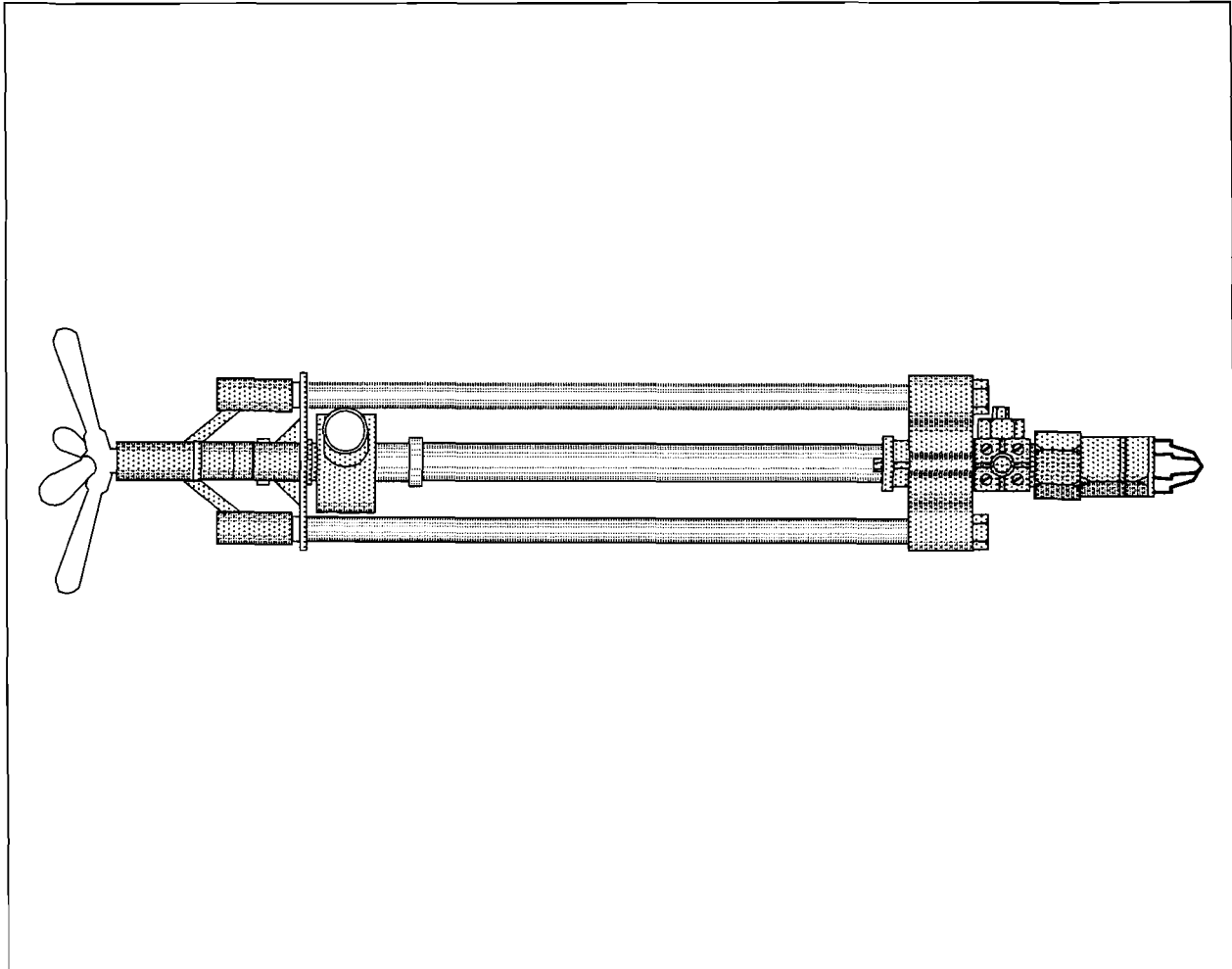

Figure 12-1: Diagram of hot tap drilling machine.

General Procedures

Plan the hot tap operation

1. Determine the capacity of the damaged tank car and the amount of product it contains, then attach a pressure gauge to the sample line or other suitable fitting and determine the internal pressure in the car.
2. Prepare a checklist of all equipment required to perform the hot tap.
3. Prepare a plan for set-up, implementation, and shut-down of the hot tap operation.
 - a. Diagram the location and orientation of the cars involved.
 - b. Diagram the location and orientation of equipment, gauges, hoses, and connections to be used in the hot tap operation.
 - c. Prepare a checklist of the procedures for set-up and implementation of the hot tap operation.
4. Prepare a site safety plan.
5. Obtain the required hot tap equipment.

Set up the hot tap operation

1. Hold a safety briefing.
2. Locate willing ASME welder certified in the 6G position.
 - a. Have welder make a minimum of three practice welds from the same position welder will be working in to actually weld the threaded nozzle in place (preferably on the same type and thickness of material).
 - b. Excavate a pit for the welder to work in, if necessary.

Implement the hot tap operation

1. Determine the internal pressure in both the damaged tank car and the receiving tank again.
2. Weld 6,000 psi coupling to tank with threaded end pointed outward.
3. Attach 6" nipple to welded coupling.
4. Attach liquid valve, in full open position, to pipe nipple.
5. Attach hot tap machine to liquid valve outlet.
6. Test equipment (coupling, liquid valve, and hot tap machine seals) for leaks:
 - a. Attach nitrogen hose to hot tap machine bleeder valve.
 - b. Set regulator on nitrogen cylinder to 500 psi (pressure tank cars) or 100 psi (for non-pressure tank cars).
 - c. Open nitrogen cylinder valve.
 - d. Open hot tap machine bleeder valve.
 - e. Check for leaks. Correct leaks as necessary.
7. Drill through tank using hot tap machine.
8. Withdraw the drill bit and close the liquid valve.

Note: The bit should be withdrawn carefully so that the steel plug is removed with the bit.
9. Remove the hot tap machine.
10. Attach liquid hoses.
11. Proceed with product-removal method (transfer, flaring, or venting operation).

This page left blank intentionally

Appendix A **Symposium Attendees**

AAR/TTC Staff

P. K. Lana, former Manager, Hazardous Material Training
K. G. Elder, Instructor, Hazardous Material Training
R. S. Marshall, former Instructor, Hazardous Material Training
J. V. Barbari, Firefighter/EMT, Hazardous Material Training
D. V. Davis, former Instructor, Hazardous Material Training
M. S. Horn, former Instructor, Hazardous Material Training
M. N. McCulloch, former Instructor, Hazardous Material Training
Gary Sammonds, former Test Engineer, Transportation Test Center

Attendees

D. C. Anderson, Response Manager, Guardian Company, Bear, DE.
H. L. Bart, Manager, Hazardous Materials Control, Southern Pacific Transportation Company, Houston, TX
C. D. Bossard, Rail Safety Coordinator, Amoco Oil Company, Chicago, IL
S. D. Buser, Director Hazardous Materials, CSX Transportation Company, Jacksonville, FL
E. D. Cannon, Trooper, Colorado State Patrol, Pueblo, CO.
H. L. Cox, former Manager Hazardous Materials, CSX Transportation Company, Jacksonville, FL
L. F. Flynn III, Laboratory Service Specialist, BASF Corporation, Geismar, LA.
D. W. Fredbeck, Director Hazardous Materials, Chicago & North Western Transportation Company, Chicago, IL
W. Groce, President, Groce Laboratories Inc, Greer, SC.
W. E. Halley, Manager, Hazardous Materials Control, Chicago & North Western Transportation Company, Chicago, IL
Capt. L. Henderson, Kentucky State Police, Frankfort, KY.
M. B. Henry, Manager Hazardous Materials, Burlington Northern Railroad, Overland Park, KS.
E. K. Hunter, General Car Foreman, Burlington Northern Railroad, Lincoln, NE.
J. D. Jarvis, Senior Inspector, Bureau of Explosives, Escondido, CA.

Symposium Attendees *(continued)*

S. Kaplan, Director, Operations, National Transportation Agency, Ottawa, ON, Canada.

H. F. Keepers, Director-Safety, Railroad Commission of Texas, Austin, TX

L. L. Lusher, former Manager Emergency Response, Union Carbide, Charleston WV.

P. A. Marbut, Assistant Director-Safety, Soo Line Railroad Company, Minneapolis, MN

A. D. Maty, Chief Inspector, AAR Bureau of Explosives, Kansas City, MO

A. C. McDougall, Special Commodities Officer, Canadian National Rail, Winnipeg, MB, Canada

S. McMahan, Distribution Specialist, Union Carbide, Charleston, WV.

J. R. McNally, Manager Hazardous Materials, Conrail, Philadelphia, PA.

J. J. O'Driscoll, President, Jody Inc. & Associates, Atlanta, GA.

J. E. Orr, former Engineer-Materials, CP Rail, Montreal, PQ, Canada

F. C. Rickert, Senior Transportation Representative and Energy Projects, Shell Oil Company, Houston, TX

M. P. Stehly, Director Environmental Quality, Atchison Topeka & Santa Fe Railway Co., Chicago, IL

Subcommittee Rosters

Transfer

Symposium Attendees

S. D. Buser
E. D. Cannon
H. L. Cox
L. F. Flynn
W. E. Halley
J. D. Jarvis
P. A. Marbut
F. C. Rickert

Staff

K. G. Elder
M. S. Horn

Symposium Attendees *(continued)*

Flaring

Symposium Attendees

C. D. Bossard

W. Groce

M. B. Henry

H. F. Keepers

J. J. O'Driscoll

Staff

D. V. Davis

M. N. McCulloch

Venting

Symposium Attendees

E. D. Cannon

L. F. Flynn

D. W. Fredbeck

L. Henderson

J. D. Jarvis

P. A. Marbut

J. J. O'Driscoll

T. E. Orr

M. P. Stehly

Staff

K. G. Elder

M. S. Horn

Hot Tapping

Symposium Attendees

H. L. Bart

D. W. Fredbeck

W. E. Halley

E. K. Hunter

H. F. Keepers

Staff

D.V. Davis

Symposium Attendees *(continued)*

Vent and Burn

Symposium Attendees

D. C. Anderson

C. D. Bossard

W. Groce

L. Henderson

S. Kaplan

L. L. Lusher

S. McMahan

J. J. O'Driscoll

Staff

M. N. McCulloch

J. V. Barbari