



NATIONAL TRANSPORTATION SAFETY BOARD  
**Investigative Hearing**

Norfolk Southern Railway general merchandise freight train 32N  
derailment with subsequent hazardous material release and fires,  
in East Palestine, Ohio, on February 3, 2023

<b>GROUP</b>	<b>E</b>
<b>EXHIBIT</b>	
22	

Agency / Organization

**FRA**

Title

**FRA CFR 49 Part 215 Appendix D**

---

This content is from the eCFR and is authoritative but unofficial.

---

**Title 49 - Transportation**

**Subtitle B - Other Regulations Relating to Transportation**

**Chapter II - Federal Railroad Administration, Department of Transportation**

## Part 215 Railroad Freight Car Safety Standards

### Subpart A General

- § 215.1 Scope of part.
- § 215.3 Application.
- § 215.5 Definitions.
- § 215.7 Prohibited acts.
- § 215.9 Movement of defective cars for repair.
- § 215.11 Designated inspectors.
- § 215.13 Pre-departure inspection.
- § 215.15 Periodic inspection.

### Subpart B Freight Car Components

#### § 215.101 Scope.

#### Suspension System

- § 215.103 Defective wheel.
- § 215.105 Defective axle.
- § 215.107 Defective plain bearing box: General.
- § 215.109 Defective plain bearing box: Journal lubrication system.
- § 215.111 Defective plain bearing.
- § 215.113 Defective plain bearing wedge.
- § 215.115 Defective roller bearing.
- § 215.117 Defective roller bearing adapter.
- § 215.119 Defective freight car truck.

#### Car Bodies

- § 215.121 Defective car body.

#### Draft System

- § 215.123 Defective couplers.
- § 215.125 Defective uncoupling device.
- § 215.127 Defective draft arrangement.
- § 215.129 Defective cushioning device.

### Subpart C Restricted Equipment

- § 215.201 Scope.
- § 215.203 Restricted cars.

### Subpart D Stenciling

- § 215.301 General.
- § 215.303 Stenciling of restricted cars.
- § 215.305 Stenciling of maintenance-of-way equipment.

## Appendix A to Part 215

### Railroad Freight Car Components

*Appendix B to Part 215 [Reserved]*

### **Appendix C to Part 215**

FRA Freight Car Standards Defect Code

### **Appendix D to Part 215**

Pre-departure Inspection Procedure

## **PART 215 - RAILROAD FREIGHT CAR SAFETY STANDARDS**

**Authority:** 49 U.S.C. 20103, 20107; 28 U.S.C. 2461 note; and 49 CFR 1.89.

**Source:** 44 FR 77340, Dec. 31, 1979, unless otherwise noted.

### **Subpart A - General**

#### **§ 215.1 Scope of part.**

This part prescribes minimum Federal safety standards for railroad freight cars.

#### **§ 215.3 Application.**

- (a) Except as provided in paragraphs (b) and (c) of this section, this part applies to each railroad freight car in service on:
  - (1) Standard gage track of a railroad; or
  - (2) Any other standard gage track while the car is being operated by, or is otherwise under the control of, a railroad.
- (b) Sections 215.15 and 215.303 of this part do not apply to any car:
  - (1) Owned by a Canadian or Mexican Railroad; and
  - (2) Having a Canadian or Mexican reporting mark and car number.
- (c) This part does not apply to a railroad freight car that is:
  - (1) Operated solely on track inside an industrial or other non-railroad installation; or
  - (2) Used exclusively in dedicated service as defined in § 215.5(d) of this part; or
  - (3) Maintenance-of-way equipment (including self-propelled maintenance-of-way equipment) if that equipment is not used in revenue service and is stenciled in accordance with § 215.305 of this part.
  - (4) Operated in a passenger train and that is inspected, tested, maintained, and operated pursuant to the requirements contained in part 238 of this chapter.

*[44 FR 77340, Dec. 31, 1979, as amended at 65 FR 41305, July 3, 2000]*

#### **§ 215.5 Definitions.**

As used in this part:

- (a) **Break** means a fracture resulting in complete separation into parts;
- (b) **Cracked** means fractured without complete separation into parts, except that castings with shrinkage cracks or hot tears that do not significantly diminish the strength of the member are not considered to be “cracked”;
- (c) **Railroad freight car** means a car designed to carry freight, or railroad personnel, by rail and includes a:
  - (1) Box car;
  - (2) Refrigerator car;
  - (3) Ventilator car;
  - (4) Stock car;
  - (5) Gondola car;
  - (6) Hopper car;
  - (7) Flat car;
  - (8) Special car;
  - (9) Caboose car;
  - (10) Tank car; and
  - (11) Yard car.
- (d) **Dedicated service** means the exclusive assignment of cars to the transportation of freight between specified points under the following conditions:
  - (1) The cars are operated -
    - (i) Primarily on track that is inside an industrial or other non-railroad installation; and
    - (ii) Only occasionally over track of a railroad;
  - (2) The cars are not operated -
    - (i) At speeds of more than 15 miles per hour; and
    - (ii) Over track of a railroad -
      - (A) For more than 30 miles in one direction; or
      - (B) On a round trip of more than 60 miles;
  - (3) The cars are not freely interchanged among railroads;
  - (4) The words “Dedicated Service” are stenciled, or otherwise displayed, in clearly legible letters on each side of the car body;
  - (5) The cars have been examined and found safe to operate in dedicated service; and
  - (6) The railroad must -
    - (i) Notify the FRA in writing that the cars are to be operated in dedicated service;
    - (ii) Identify in that notice -

- (A) The railroads affected;
  - (B) The number and type of cars involved;
  - (C) The commodities being carried; and
  - (D) The territorial and speed limits within which the cars will be operated; and
- (iii) File the notice required by this paragraph not less than 30 days before the cars operate in dedicated service;
- (e) **In service** when used in connection with a railroad freight car, means each railroad freight car subject to this part unless the car:
- (1) Has a “bad order” or “home shop for repairs” tag or card containing the prescribed information attached to each side of the car and is being handled in accordance with § 215.9 of this part;
  - (2) Is in a repair shop or on a repair track;
  - (3) Is on a storage track and is empty; or
  - (4) Has been delivered in interchange but has not been accepted by the receiving carrier.
- (f) **Railroad** means all forms of non-highway ground transportation that run on rails or electromagnetic guideways, including
- (1) commuter or other short-haul rail passenger service in a metropolitan or suburban area, and
  - (2) high speed ground transportation systems that connect metropolitan areas, without regard to whether they use new technologies not associated with traditional railroads. Such term does not include rapid transit operations within an urban area that are not connected to the general railroad system of transportation.
- (g) **State inspector** means an inspector who is participating in investigative and surveillance activities under section 206 of the Federal Railroad Safety Act of 1970 (45 U.S.C. 435).

[44 FR 77340, Dec. 31, 1979, as amended at 45 FR 26710, Apr. 21, 1980; 54 FR 33228, Aug. 14, 1989]

## § 215.7 Prohibited acts.

Any person (an entity of any type covered under 1 U.S.C. 1, including but not limited to the following: a railroad; a manager, supervisor, official, or other employee or agent of a railroad; any owner, manufacturer, lessor, or lessee of railroad equipment, track, or facilities; any independent contractor providing goods or services to a railroad; and any employee of such owner, manufacturer, lessor, lessee, or independent contractor) who violates any requirement of this part or causes the violation of any such requirement is subject to a civil penalty of at least \$1,052 and not more than \$34,401 per violation, except that: Penalties may be assessed against individuals only for willful violations, and, where a grossly negligent violation or a pattern of repeated violations has created an imminent hazard of death or injury to persons, or has caused death or injury, a penalty not to exceed \$137,603 per violation may be assessed. Each day a violation continues shall constitute a separate offense. See FRA's website at www.fra.dot.gov for a statement of agency civil penalty policy.

[53 FR 28599, July 28, 1988, as amended at 53 FR 52925, Dec. 29, 1988; 63 FR 11620, Mar. 10, 1998; 69 FR 30593, May 28, 2004; 72 FR 51196, Sept. 6, 2007; 73 FR 79701, Dec. 30, 2008; 77 FR 24419, Apr. 24, 2012; 81 FR 43109, July 1, 2016; 82 FR 16132, Apr. 3, 2017; 83 FR 60746, Nov. 27, 2018; 84 FR 23734, May 23, 2019; 84 FR 37072, July 31, 2019; 86 FR 1757, Jan. 11, 2021; 86 FR 23253, May 3, 2021; 87 FR 15867, Mar. 21, 2022; 88 FR 1126, Jan. 6, 2023]

## § 215.9 Movement of defective cars for repair.

- (a) A railroad freight car which has any component described as defective in this part may be moved to another location for repair only after the railroad has complied with the following:
  - (1) A person designated under § 215.11 shall determine:
    - (i) That it is safe to move the car; and
    - (ii) The maximum speed and other restrictions necessary for safely conducting the movement;
  - (2)
    - (i) The person in charge of the train in which the car is to be moved shall be notified in writing and inform all other crew members of the presence of the defective car and the maximum speed and other restrictions determined under paragraph (a)(1)(ii) of this section.
    - (ii) A copy of the tag or card described in paragraph (a)(3) of this section may be used to provide the notification required by paragraph (a)(2)(i) of this section.
  - (3) A tag or card bearing the words “bad order” or “home shop for repairs” and containing the following information, shall be securely attached to each side of the car -
    - (i) The reporting mark and car number;
    - (ii) The name of the inspecting railroad;
    - (iii) The inspection location and date;
    - (iv) The nature of each defect;
    - (v) Movement restrictions;
    - (vi) The destination for shopping or repair; and
    - (vii) The signature of a person designated under § 215.11.
- (b)
  - (1) The tag or card required by paragraph (a)(3) of this section may only be removed from the car by a person designated under § 215.11 of this part.
  - (2) A record or copy of each tag or card attached to or removed from a car shall be retained for 90 days and, upon request, shall be made available within 15 calendar days for inspection by FRA or State inspectors.
  - (3) Each tag or card removed from a car shall contain a notification stating the date, location, reason for its removal, and the signature of the person who removed it from the car. These recordkeeping requirements have been approved by the Office of Management and Budget in accordance with the Federal Reports Act of 1942.

- (c) Movement of a freight car under paragraph (a) of this section may be made only for the purpose of effecting repairs. If the car is empty, it may not be placed for loading. If the car is loaded, it may not be placed for unloading unless unloading is consistent with determinations made and restrictions imposed under paragraph (a)(1) of this section and -
  - (1) The car is consigned for a destination on the line of haul between the point where the car was found defective and the point where repairs are made; or
  - (2) Unloading is necessary for the safe repair of the car.
- (d) Nothing in this section authorizes the movement of a freight car subject to a Special Notice for Repairs unless the movement is made in accordance with the restrictions contained in the Special Notice.

[44 FR 77340, Dec. 31, 1979; 45 FR 26710, Apr. 21, 1980]

### § 215.11 Designated inspectors.

- (a) Each railroad that operates railroad freight cars to which this part applies shall designate persons qualified to inspect railroad freight cars for compliance with this part and to make the determinations required by § 215.9 of this part.
- (b) Each person designated under this section shall have demonstrated to the railroad a knowledge and ability to inspect railroad freight cars for compliance with the requirements of this part and to make the determinations required by § 215.9 of this part.
- (c) With respect to designations under this section, each railroad shall maintain written records of:
  - (1) Each designation in effect; and
  - (2) The basis for each designation.

[45 FR 26710, Apr. 21, 1980]

### § 215.13 Pre-departure inspection.

- (a) At each location where a freight car is placed in a train, the freight car shall be inspected before the train departs. This inspection may be made before or after the car is placed in the train.
- (b) At a location where an inspector designated under § 215.11 is on duty for the purpose of inspecting freight cars, the inspection required by paragraph (a) of this section shall be made by that inspector to determine whether the car is in compliance with this part.
- (c) At a location where a person designated under § 215.11 is not on duty for the purpose of inspecting freight cars, the inspection required by paragraph (a) shall, as a minimum, be made for those conditions set forth in appendix D to this part.
- (d) Performance of the inspection prescribed by this section does not relieve a railroad of its liability under § 215.7 for failure to comply with any other provision of this part.

[45 FR 26710, Apr. 21, 1980]



## § 215.15 Periodic inspection.

- (a) After June 30, 1980, a railroad may not place or continue in service a freight car that has not received an initial periodic inspection in accordance with 49 CFR 215.25, as in effect on October 6, 1976 (41 FR 44044), unless -
  - (1) The car is a high utilization car built or reconditioned after December 31, 1977; or
  - (2) The car is a non-high utilization car built or reconditioned after December 31, 1971.
- (b) A freight car that has received an initial periodic inspection under paragraph (a) of this section shall be stenciled to so indicate in accordance with 49 CFR 215.11 and appendix C of this part, as in effect on October 6, 1976 (41 FR 44044). This stenciling need not be retained on the car after June 30, 1981.
- (c) As used in this section, "high utilization car" means a car -
  - (1) Specifically equipped to carry trucks, automobiles, containers, trailers, or removable trailer bodies for the transportation of freight; or
  - (2) Assigned to a train that operates in a continuous round trip cycle between the same two points.

## Subpart B - Freight Car Components

### § 215.101 Scope.

This subpart contains safety requirements prohibiting a railroad from placing or continuing in service a freight car that has certain defective components.

#### SUSPENSION SYSTEM

### § 215.103 Defective wheel.

A railroad may not place or continue in service a car, if -

- (a) A wheel flange on the car is worn to a thickness of  $\frac{7}{8}$  of an inch, or less, at a point  $\frac{3}{8}$  of an inch above the tread of the wheel;
- (b) The height of a wheel flange on the car, from the tread to the top of the flange, is  $1\frac{1}{2}$  inches, or more;
- (c) The thickness of a rim of a wheel on the car is  $\frac{11}{16}$  of an inch, or less;
- (d) A wheel rim, flange, plate, or hub area on the car has a crack or break;
- (e) A wheel on the car has a chip or gouge in the flange that is  $1\frac{1}{2}$  inches in length and  $\frac{1}{2}$  inch in width, or more;
- (f) A wheel on the car has -
  - (1) A slid flat or shelled spot that is more than  $2\frac{1}{2}$  inches in length; or
  - (2) Two adjoining flat or shelled spots each of which is more than two inches in length;
- (g) A wheel on the car shows evidence of being loose such as oil seepage on the back hub or back plate;

- (h) A wheel on the car shows signs of having been overheated as evidenced by a reddish brown discoloration, to a substantially equal extent on both the front and the back face of the rim, that extends on either face more than four inches into the plate area measured from the inner edge of the front or back face of the rim; or,
- (i) A wheel on the car has been welded unless the car is being moved for repair in accordance with § 215.9 of this part.

[44 FR 77340, Dec. 31, 1979, as amended at 50 FR 13382, Apr. 4, 1985]

### § 215.105 Defective axle.

A railroad may not place or continue in service a car, if -

- (a) An axle on the car has a crack or is broken;
- (b) An axle on the car has a gouge in the surface that is -
  - (1) Between the wheel seats; and
  - (2) More than one-eighth inch in depth;
- (c) An axle on the car, used in conjunction with a plain bearing, has an end collar that is broken or cracked;
- (d) A journal on the car shows evidence of overheating, as evidenced by a pronounced blue black discoloration; or
- (e) The surface of the plain bearing journal on the axle, or the fillet on the axle, has -
  - (1) A ridge;
  - (2) A depression;
  - (3) A circumferential score;
  - (4) Corrugation;
  - (5) A scratch;
  - (6) A continuous streak;
  - (7) Pitting;
  - (8) Rust; or
  - (9) Etching.

### § 215.107 Defective plain bearing box: General.

A railroad may not place or continue in service a car, if the car has -

- (a) A plain bearing box that does not contain visible free oil;
- (b) A plain bearing box lid that is missing, broken, or open except to receive servicing; or
- (c) A plain bearing box containing foreign matter, such as dirt, sand, or coal dust, that can reasonably be expected to -

- (1) Damage the bearing; or
- (2) Have a detrimental effect on the lubrication of the journal and the bearings.

**§ 215.109 Defective plain bearing box: Journal lubrication system.**

A railroad may not place or continue in service a car, if the car has a plain bearing box with a lubricating pad that -

- (a) Has a tear extending half the length or width of the pad, or more;
- (b) Shows evidence of having been scorched, burned, or glazed;
- (c) Contains decaying or deteriorated fabric that impairs proper lubrication of the pad;
- (d) Has -
  - (1) An exposed center core (except by design); or
  - (2) Metal parts contacting the journal; or
- (e) Is -
  - (1) Missing; or
  - (2) Not in contact with the journal.

**§ 215.111 Defective plain bearing.**

A railroad may not place or continue in service a car, if the car has a plain bearing -

- (a) That is missing, cracked, or broken;
- (b) On which the bearing liner -
  - (1) Is loose; or
  - (2) Has a broken out piece; or
- (c) That shows signs of having been overheated, as evidenced by -
  - (1) Melted babbitt;
  - (2) Smoke from hot oil; or
  - (3) Journal surface damage.

**§ 215.113 Defective plain bearing wedge.**

A railroad may not place or continue in service a car, if a plain bearing wedge on that car is -

- (a) Missing;
- (b) Cracked;
- (c) Broken; or
- (d) Not located in its design position.

### § 215.115 Defective roller bearing.

- (a) A railroad may not place or continue in service a car, if the car has -
  - (1) A roller bearing that shows signs of having been overheated as evidenced by -
    - (i) Discoloration; or
    - (ii) Other telltale signs of overheating such as damage to the seal or distortion of any bearing component;
  - (2) A roller bearing with a -
    - (i) Loose or missing cap screw; or
    - (ii) Broken, missing, or improperly applied cap screw lock; or
  - (3) A roller bearing with a seal that is loose or damaged, or permits leakage of lubricant in clearly formed droplets.
- (b)
  - (1) A railroad may not continue in service a car that has a roller bearing whose truck was involved in a derailment unless the bearing has been inspected and tested by:
    - (i) Visual examination to determine whether it shows any sign of damage; and
    - (ii) Spinning freely its wheel set or manually rotating the bearing to determine whether the bearing makes any unusual noise.
  - (2) The roller bearing shall be disassembled from the axle and inspected internally if -
    - (i) It shows any external sign of damage;
    - (ii) It makes any unusual noise when its wheel set is spun freely or the bearing is manually rotated;
    - (iii) Its truck was involved in a derailment at a speed of more than 10 miles per hour; or
    - (iv) Its truck was dragged on the ground for more than 200 feet.
  - (3) Each defective roller bearing shall be repaired or replaced before the car is placed back in service.

[44 FR 77340, Dec. 31, 1979, as amended at 45 FR 26711, Apr. 21, 1980]

### § 215.117 Defective roller bearing adapter.

A railroad may not place or continue in service a car, if the car has a roller bearing adapter that is -

- (a) Cracked or broken;
- (b) Not in its design position; or
- (c) Worn on the crown of the adapter to the extent that the frame bears on the relief portion of the adapter, as shown in the figure below (see figure 1).

### § 215.119 Defective freight car truck.

A railroad may not place or continue in service a car, if the car has -

- (a) A side frame or bolster that -
  - (1) Is broken; or
  - (2) Has a crack of  $\frac{1}{4}$  of an inch or more in the transverse direction on a tension member;
- (b) A truck equipped with a snubbing device that is ineffective, as evidenced by -
  - (1) A snubbing friction element that is worn beyond a wear indicator;
  - (2) A snubber wear plate that is loose, missing (except by design), or worn through;
  - (3) A broken or missing snubber activating spring; or

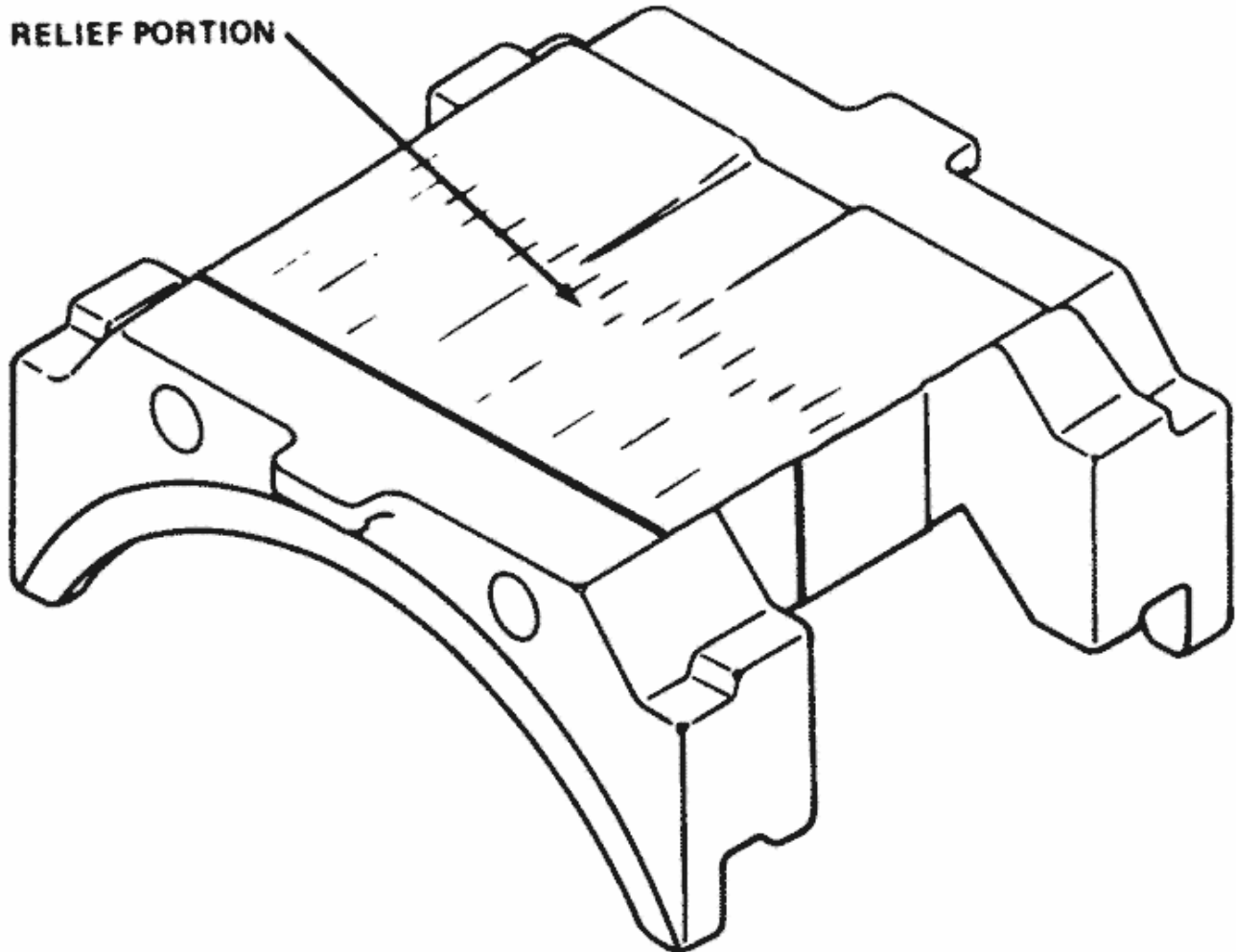

**FIGURE 1**

- (4) Snubber unit that is broken, or in the case of hydraulic units, is broken or leaking clearly formed droplets of oil or other fluid.
- (c) A side bearing in any of the following conditions:
  - (1) Part of the side bearing assembly is missing or broken;
  - (2) The bearings at one end of the car, on both sides, are in contact with the body bolster (except by design);

- (3) The bearings at one end of the car have a total clearance from the body bolster of more than  $\frac{3}{4}$  of an inch; or
- (4) At diagonally opposite sides of the car, the bearings have a total clearance from the body bolsters of more than  $\frac{3}{4}$  of an inch;
- (d) Truck springs -
  - (1) That do not maintain travel or load;
  - (2) That are compressed solid; or
  - (3) More than one outer spring of which is broken, or missing, in any spring cluster;
- (e) Interference between the truck bolster and the center plate that prevents proper truck rotations; or
- (f) Brake beam shelf support worn so excessively that it does not support the brake beam.

#### CAR BODIES

### § 215.121 Defective car body.

A railroad may not place or continue in service a car, if:

- (a) Any portion of the car body, truck, or their appurtenances (except wheels) has less than a  $2\frac{1}{2}$  inch clearance from the top of rail;
- (b) The car center sill is:
  - (1) Broken;
  - (2) Cracked more than 6 inches; or
  - (3) Permanently bent or buckled more than  $2\frac{1}{2}$  inches in any six foot length;
- (c) The car has a coupler carrier that is:
  - (1) Broken;
  - (2) Missing;
  - (3) Non-resilient and the coupler has a type F head.
- (d) After December 1, 1983, the car is a box car and its side doors are not equipped with operative hangers, or the equivalent, to prevent the doors from becoming disengaged.
- (e) The car has a center plate:
  - (1) That is not properly secured;
  - (2) Any portion of which is missing; or
  - (3) That is broken; or
  - (4) That has two or more cracks through its cross section (thickness) at the edge of the plate that extend to the portion of the plate that is obstructed from view while the truck is in place; or
- (f) The car has a broken sidesill, crossbearer, or body bolster.

[44 FR 77340, Dec. 31, 1979, as amended at 47 FR 53737, Dec. 29, 1982]

DRAFT SYSTEM

**§ 215.123 Defective couplers.**

A railroad may not place or continue in service a car, if -

- (a) The car is equipped with a coupler shank that is bent out of alignment to the extent that the coupler will not couple automatically with the adjacent car;
- (b) The car has a coupler that has a crack in the highly stressed junction area of the shank and head as shown in the figure below (see figure 2).
- (c) The car has a coupler knuckle that is broken or cracked on the inside pulling face of the knuckle.
- (d) The car has a knuckle pin or knuckle thrower that is:
  - (1) Missing; or
  - (2) Inoperative; or
- (e) The car has a coupler retainer pin lock that is -

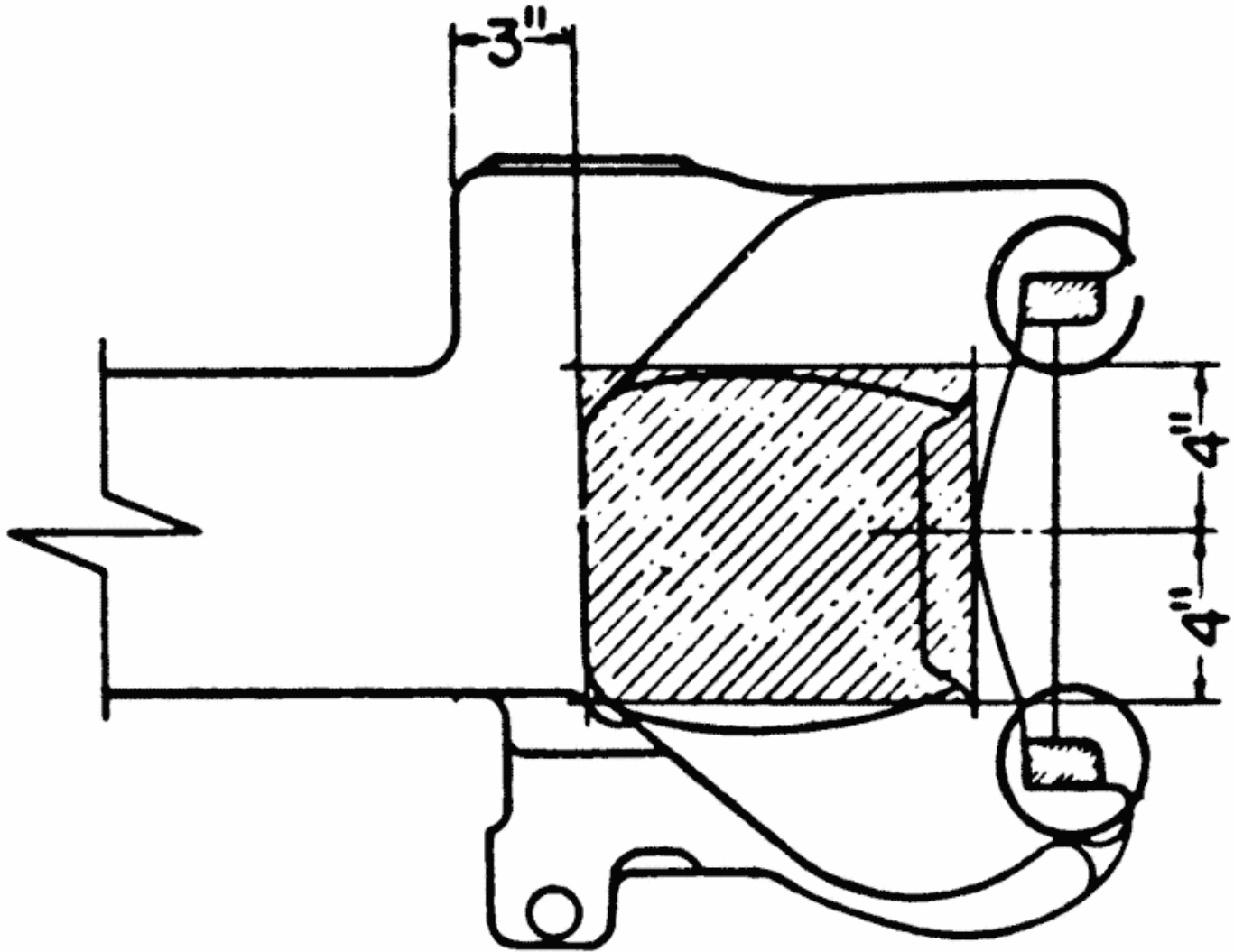

Figure 2

- 
- (1) Missing; or
  - (2) Broken; or
  - (f) The car has a coupler with any of the following conditions:
    - (1) The locklift is inoperative;
    - (2) The coupler assembly does not have anticreep protection to prevent unintentional unlocking of the coupler lock; or
    - (3) The coupler lock is -
      - (i) Missing;
      - (ii) Inoperative;



- (iii) Bent;
- (iv) Cracked; or
- (v) Broken.

### § 215.125 Defective uncoupling device.

A railroad may not place or continue in service a car, if the car has an uncoupling device without sufficient vertical and lateral clearance to prevent -

- (a) Fouling on curves; or
- (b) Unintentional uncouplings.

### § 215.127 Defective draft arrangement.

A railroad may not place or continue in service a car, if -

- (a) The car has a draft gear that is inoperative;
- (b) The car has a broken yoke;
- (c) An end of car cushioning unit is -
  - (1) Leaking clearly formed droplets; or
  - (2) Inoperative;
- (d) A vertical coupler pin retainer plate -
  - (1) Is missing (except by design); or
  - (2) Has a missing fastener;
- (e) The car has a draft key, or draft key retainer, that is -
  - (1) Inoperative; or
  - (2) Missing; or
- (f) The car has a missing or broken follower plate.

### § 215.129 Defective cushioning device.

A railroad may not place or continue in service a car if it has a cushioning device that is -

- (a) Broken;
- (b) Inoperative; or
- (c) Missing a part -

unless its sliding components have been effectively immobilized.

## Subpart C - Restricted Equipment

## § 215.201 Scope.

This subpart contains requirements restricting the use of certain railroad freight cars.

## § 215.203 Restricted cars.

- (a) This section restricts the operation of any railroad freight car that is -
  - (1) More than 50 years old, measured from the date of original construction;
  - (2) Equipped with any design or type component listed in appendix A to this part; or
  - (3) Equipped with a Duryea underframe constructed before April 1, 1950, except for a caboose which is operated as the last car in a train.
- (b) A railroad may not place or continue in service a railroad freight car described in paragraph (a) of this section, except under conditions approved by the Federal Railroad Administrator.
- (c) A railroad may petition the Administrator to continue in service a car described in paragraph (a) of this section. Each petition shall be
  - (1) Be submitted not less than 90 days before the car is to be operated;
  - (2) Be submitted; and
  - (3) State or describe the following:
    - (i) The name and principal business address of the petitioning railroad.
    - (ii) The name and address of the entity that controls the operation and maintenance of the car involved.
    - (iii) The number, type, capacity, reporting marks, and car numbers of the cars, their condition, status, and age measured from the date of original construction.
    - (iv) The design, type component, or other item that causes the car to be restricted.
    - (v) The maximum load the cars would carry.
    - (vi) The maximum speed at which the cars would be operated.
    - (vii) That each car has been examined and found to be safe to operate under the conditions set forth in the petition.
    - (viii) The territorial limits within which the cars are to be operated and the name of each railroad that will receive the cars in interchange.

[44 FR 77340, Dec. 31, 1979, as amended at 74 FR 25172, May 27, 2009]

## Subpart D - Stenciling

### § 215.301 General.

The railroad or private car owner reporting mark, the car number, and built date shall be stenciled, or otherwise displayed, in clearly legible letters and numbers not less than seven inches high, except those of the built date which shall not be less than one inch high:

- (a) On each side of each railroad freight car body; and
- (b) In the case of a tank car, in any location that is visible to a person walking at track level beside the car.

### § 215.303 Stenciling of restricted cars.

- (a) Each restricted railroad freight car that is described in § 215.205(a) of this part shall be stenciled, or marked -
  - (1) In clearly legible letters; and
  - (2) In accordance with paragraphs (b) and (c) of this section.
- (b) The letter "R" shall be -
  - (1) Placed immediately below or to the right of the car number;
  - (2) The same color as the reporting mark; and
  - (3) The same size as the reporting mark.
- (c) The following terms, to the extent needed to completely indicate the basis for the restricted operation of the car, shall be placed on the car following the symbol "R" in letters not less than one inch high:
  - (1) Age.
  - (2) Coupler.
  - (3) Draft.
  - (4) Bearings.
  - (5) Truck.
  - (6) Underframe.
  - (7) Wheels.
  - (8) Yoke.

### § 215.305 Stenciling of maintenance-of-way equipment.

- (a) Maintenance-of-way equipment (including self-propelled maintenance-of-way equipment) described in § 215.3(c)(3) shall be stenciled, or marked -
  - (1) In clearly legible letters; and
  - (2) In accordance with paragraph (b) of this section.
- (b) The letters "MW" must be -
  - (1) At least 2 inches high; and
  - (2) Placed on each side of the car.

[44 FR 77340, Dec. 31, 1979, as amended at 45 FR 26711, Apr. 21, 1980]

## Appendix A to Part 215 - Railroad Freight Car Components

List of components whose use is restricted by § 215.203 of this part.

A. Air brakes:

The "K" type.

B. Axles:

1. Former AAR alternate standard tubular type.
2. Axle with letters "RJ" stamped on the end of the journal.

C. Couplers:

1. AAR type "D", top or bottom operated.
2. AAR type "E" with 5" by 7" shank.

D. Draft arrangement:

1. Miner FR-16 and FR-19-F draft gears.
2. Farlow draft attachment.

E. Plain journal bearings:

Cartridge type.

F. Roller bearings:

1. Nippon Sieko Kabushiki Kaish (NSK) size 6<sup>1</sup>/<sub>2</sub>" by 12" (marked "AAR 11").
2. Hyatt cylindrical bearing, all sizes (marked "AAR 2").
3. SKF "Piggybacker" spherical roller, size 6" by 11" (marked "AAR 7").

G. Trucks:

1. Arch bar type.
2. Truck with cast steel pedestal side frame, short wheel base, and no bolster.

H. Truck bolsters:

1. A bolster with one of the following pattern numbers listed according to manufacturer:

A.S.F.	Dresser (Symington)	Birdsboro	Lenoir car works
21183-B	BO 5234	1458	CS-184.
		1468	
21183-N	BO 5263	1471	CS-611.
	BO 7076		
21648-C	BO 7076-A		
22056-E	BO 7115		

2. Bolster cast before 1927.
3. Bolster without an identification mark or pattern number.

I.

1. Truck side frames:

A side frame with one of the following pattern numbers listed according to manufacturer:

A.S.F.	National castings	Buckeye	Dominion
7273	33793-1B	3-1776	TF-5100
7323		F-420	
21362 (cast prior to June 1941)			

Pittsburgh steel foundry	Scullin steel	Bettendorf	Canadian steel foundry
31673	42-CS-180	UT 456	26565
4-1862			
3-1674	4665		
4-2045	4770		
12897	4942		
12921	5220		
21263	5364		
	5364-C		
	5364-E		
	5811-A		
	5869-B		
	6577-A		

2. Side frame cast before 1927.
3. Side frame without an identification mark or pattern number.
4. Side frame with an "I", "T", or "L" section compression or tension member.

J. Wheels:

1. Cast iron wheel.
2. Cast steel wheel marked "AAR X-2."
3. Southern cast steel wheel manufactured before May 7, 1958.
4. Griffin, three-riser cast steel wheel, ball rim design, 70-ton capacity.
5. Griffin, three-riser cast steel wheel, two-wear, 70- and 50-ton capacity, 33 inch, (marked X-5 or CS-2).
6. Wrought steel wheel manufactured before 1927, as indicated by marking on wheel.
7. Cast steel wheel marked AAR X-4.
8. Davis cast steel wheel.
9. One-wear, 70-ton Southern (ABEX) U1 cast steel wheels dated May 7, 1958 through December 31, 1969.

- A. Wheels dated May 7, 1958, to January 1, 1964, are marked with the symbol "70T" cast on the back of the wheel plate; they are not marked "U-1."
- B. Wheels dated January 1, 1964 through December 31, 1969, are marked with the symbols "CJ-33" and "U-1" or "70T" and "U-1" cast on the back of the wheel plate.

K. Yokes:

- 1. Riveted type.
- 2. Keyless type.
- 3. Vertical key type.

## Appendix B to Part 215 [Reserved]

## Appendix C to Part 215 - FRA Freight Car Standards Defect Code

The following defect code has been established for use by FRA and State inspectors to report defects observed during inspection of freight cars. The purpose of the code is to establish a uniform language among FRA, States, and the railroad industry that will facilitate communication, recordkeeping, and statistical analyses. The code may not be substituted for the description of defects on bad order tags affixed to cars being moved for repair under § 215.9. However, it may be used to supplement that description.

## Index

### General

215.009 Improper Movement of Defective Cars.

215.011 Designation of Qualified Persons.

215.013 Failure to Perform a Pre-departure Inspection.

215.015 Failure to Complete Initial Periodic Inspection as Required.

### Freight Car Components

### Suspension System

215.103 Defective Wheel.

215.105 Defective Axle.

215.107 Defective Plain Bearing Box: General.

215.109 Defective Plain Bearing Box: Journal Lubrication System.

215.111 Defective Plain Bearing.

215.113 Defective Plain Bearing Wedge.

215.115 Defective Roller Bearing.

215.117 Defective Roller Bearing Adapter.

215.119 Defective Freight Car Truck.

## **Car Bodies**

215.121 Defective Car Body.

## **Draft System**

215.123 Defective Couplers.

215.125 Defective Uncoupling Device.

215.127 Defective Draft Arrangement.

215.129 Defective Cushioning Device.

## **Restricted Equipment**

215.203 Restricted Cars.

## **Stenciling**

215.301 Improper Stenciling.

215.303 Improper Stenciling of Restricted Cars.

215.305 Improper Stenciling of Maintenance-of-Way Equipment.

## **Description of Defects**

215.009 Failure to meet conditions for movement of defective cars for repairs.

215.011 Designation of Qualified Persons.

(A)

- (1) Railroad fails to designate persons qualified to inspect freight cars;
- (2) Persons designated does not have knowledge and ability to inspect freight cars for compliance with the requirements of this part.

(B) Railroad fails to maintain written record of:

- (1) Each designation in effect;
- (2) The basis for this designation.

215.013 Failure to perform pre-departure inspection.

215.015 Periodic Inspection.

(A) Railroad fails to perform the periodic inspection as required by June 30, 1980 on:

- (1) High utilization car built prior to December 31, 1977;
- (2) Non-high utilization car built prior to December 31, 1971;

(B) A freight car improperly stenciled for periodic inspection.

215.103 Defective Wheel.

(A)

- (1) Flanges  $\frac{7}{8}$ " or less at  $\frac{3}{8}$ " above the tread;
- (2) Flanges  $\frac{13}{16}$ " or less at  $\frac{3}{8}$ " above the tread;
- (3) Flanges  $\frac{3}{4}$ " or less at  $\frac{3}{8}$ " above the tread;

(B)

- (1) Flange is  $1\frac{1}{2}$ " or more from the tread to top of flange;
- (2) Flange is  $1\frac{5}{8}$ " or more from the tread to top of flange;
- (3) Flange is  $1\frac{3}{4}$ ".

(C)



- (1) Rim thickness is  $1^{1/16}$ " or less;
- (2) Rim thickness is  $5/8$ " or less;
- (3) Rim thickness is  $9/16$ " or less;
- (D) Wheel cracked or broken in:
  - (1) rim,
  - (2) flange,
  - (3) plate or
  - (4) hub area.
- (E) Wheel chip or gouge in flange:
  - (1)  $1^{1/2}$ " length and  $1/2$ " in width or more;
  - (2)  $1^{5/8}$ " length and  $5/8$ " in width or more;
  - (3)  $1^{3/4}$ " in length and  $3/4$ " in width or more.
- (F) Wheel has slid flat spot or shelled spot:
  - (1)  $2^{1/2}$ " in length or more;
  - (2) Has two adjoining flat spots each of which is 2" in length or greater;
  - (3) A single flat spot 3" in length or more;
  - (4) Has two adjoining flat spots one of which is at least 2" in length and the other is  $2^{1/2}$ " or greater.
- (G) Has a loose wheel.
- (H) Overheated with discoloration extending: (1) More than 4"; (2)  $4^{1/2}$ " or more.
- (I) A welded wheel on car that is not moving for repairs.

215.105 Defective Axle.

- (A) Cracked or broken:
  - (1) Cracked 1' or less;

- (2) Cracked greater than 1";
- (3) Broken or cracked with visible separation of metal.

(B) Gouge between wheel seats more than  $\frac{1}{8}$ " in depth:

(C) Broken or cracked end collar on plain bearing axle.

(D) Overheated journal.

(E) Surface of plain bearing journal or fillet has

- (1) ridge,
- (2) depression,
- (3) circumferential score,
- (4) corrugation,
- (5) scratch,
- (6) continuous streak,
- (7) pitting,
- (8) rust, (9) etching.

215.107 Defective plain bearing box.

(A)

(1) Does not contain visible free oil;

(2) A journal box with dry pad.

(B) Lid is missing, broken or open except to receive service.

(C) Box has foreign matter that will damage bearing or prevent lubrication.

215.109 Defective plain bearing box: journal lubrication system.

(A) Pad torn half the length or width.

(B) Scorched, burned or glazed.

- (C) Contains decaying or deteriorated fabric.
- (D) Has exposed core except by design of metal parts in contact with journal.
- (E)
  - (1) Missing;
  - (2) Not in contact with journal.

215.111 Defective plain bearing.

- (A) Missing, cracked or broken.
- (B)
  - (1) Bearing lining is loose;
  - (2) Broken out piece.
- (C) Overheated as evidenced by:
  - (1) Melted babbit;
  - (2) Smoke from hot oil;
  - (3) Journal surface damaged.

215.113 Defective plain bearing wedge.

- (A) Missing.
- (B) Cracked.
- (C) Broken.
- (D) Not located in design position.

215.115 Defective roller bearing.

- (A)
  - (1) Overheated;
  - (2) Loose or missing cap screw;

- (3) Roller bearing seal loose or damaged permitting loss of lubricant;
- (4) Two or more missing cap screws.

(B)

- (1) Failure to inspect if involved in derailment;
- (2) Failure to disassemble if required under this part;
- (3) Failure to repair or replace defective roller bearings.

215.117 Defective roller bearing adapter.

- (A) Cracked or broken.
- (B) Not in design position.
- (C) Worn excessively as shown on Figure 1 in relief portion.

215.119 Defective freight car trucks.

(A)

- (1) Side frame or bolster broken;
- (2) Cracked  $\frac{1}{4}$ " or more in transverse direction on tension member;
- (3) Cracked 1" or more in transverse direction on tension member.

(B) Has ineffective snubbing devices.

(C)

- (1) Missing or broken side bearing;
- (2) Side bearing in contact except by design;
- (3) Excessive side bearing clearance at one end of car;
- (4) Excessive side bearing clearance on opposite sides at diagonal ends of car.

(D)

- (1) Has truck springs that will not maintain travel or load;

- (2) Truck springs that are compressed solid;
- (3) Has two springs broken in a cluster;
- (4) Has three or more springs broken.
- (E) Truck bolster and center plate interference preventing rotation.
- (F) Has broken beam shelf supports worn so that shelf will not support beam.

215.121 Defective car body.

- (A) Improper clearance - less than  $2\frac{1}{2}$ " from top of rail.
- (B) Center sill is:
  - (1) Broken;
  - (2) Cracked more than 6";
  - (3) Bent or buckled more than  $2\frac{1}{2}$ " in any 6-foot length.
- (C) Coupler carrier is:
  - (1) Broken;
  - (2) Missing;
  - (3) Non-resilient when used with coupler with F head.
- (D) Car door not equipped with operative safety hangers.
- (E) If center plate:
  - (1) Any portion missing;
  - (2) Broken or cracked as defined in this part.
- (F) Broken side sills, crossbars or body bolster.

215.123 Defective couplers.

- (A) Coupler shank bent.
- (B) Coupler cracked in highly stressed area of head and shank.

- (C) Coupler knuckle broken.
- (D) Coupler knuckle pin or knuckle throw:
  - (1) Missing;
  - (2) Inoperative.
- (E) Coupler retainer pin lock:
  - (1) Missing;
  - (2) Broken.
- (F)
  - (1) Coupler locklift is inoperative;
  - (2) No anti-creep protection;
  - (3) Coupler lock is
    - (i) missing,
    - (ii) inoperative,
    - (iii) bent,
    - (iv) cracked or (v) broken.

215.125 Defective uncoupling device.

- (A) Fouling on curve.
- (B) Unintentional uncoupling.

215.127 Defective draft arrangement.

- (A) Draft gear inoperative.
- (B) Broken yoke.
- (C) End of car cushioning unit:
  - (1) Leaking;

(2) Inoperative.

(D) Vertical coupler pin retainer plate:

(1) Missing;

(2) Has missing fastener.

(E) Draft key or key retainer:

(1) Inoperative;

(2) Missing.

(F) Follower plate missing or broken.

215.129 Defective cushioning device unless effectively immobilized.

(A) Broken.

(B) Inoperative.

(C) Missing parts.

215.203 Operating a restricted car, except under conditions approved by FRA.

## Stenciling

215.301 Failure to stencil car number and built date on freight car as required.

215.303 Failure to stencil restricted car as required.

215.305 Failure to stencil maintenance-of-way equipment as required.

## Appendix D to Part 215 - Pre-departure Inspection Procedure

At each location where a freight car is placed in a train and a person designated under § 215.11 is not on duty for the purpose of inspecting freight cars, the freight car shall, as a minimum, be inspected for the imminently hazardous conditions listed below that are likely to cause an accident or casualty before the train arrives at its destination. These conditions are readily discoverable by a train crew member in the course of a customary inspection.

1. Car body:

(a) Leaning or listing to side.

(b) Sagging downward.

- (c) Positioned improperly on truck.
  - (d) Object dragging below.
  - (e) Object extending from side.
  - (f) Door insecurely attached.
  - (g) Broken or missing safety appliance.
  - (h) Lading leaking from a placarded hazardous material car.
2. Insecure coupling.
  3. Overheated wheel or journal.
  4. Broken or extensively cracked wheel.
  5. Brake that fails to release.
  6. Any other apparent safety hazard likely to cause an accident or casualty before the train arrives at its destination.

*[45 FR 26711, Apr. 21, 1980, as amended at 73 FR 79701, Dec. 30, 2008]*