



NATIONAL TRANSPORTATION SAFETY BOARD

Investigative Hearing

Norfolk Southern Railway general merchandise freight train 32N
derailment with subsequent hazardous material release and fires,
in East Palestine, Ohio, on February 3, 2023

GROUP	C
EXHIBIT	
10	

Agency / Organization

Norfolk Southern Railway

Title

**Railroad
Emergency Response Planning Guide**

March 2019



RAILROAD EMERGENCY RESPONSE PLANNING GUIDE



Item #882037 (Rev. 3/19)

March 2019

Norfolk Southern Railway Company
Safety & Environmental Department
1200 Peachtree Street, NE – Box 13
Atlanta, GA 30309

About NORFOLK SOUTHERN



19,500 ROUTE MILES
across 22 STATES & D.C.



MAKING CONNECTIONS

Norfolk Southern (NYSE: NSC) has served the freight transportation needs of America for nearly two centuries, connecting businesses and communities to the marketplaces of the world — creating jobs, supporting economies, and transporting goods on safe, environmentally friendly rail.

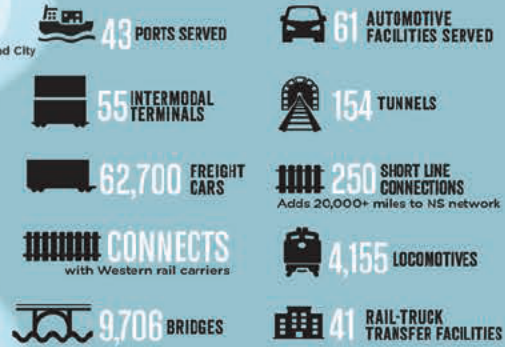

← GATEWAY CITIES TO WESTERN CARRIERS

DELIVERING FOR AMERICAN INDUSTRY AND CONSUMERS

NS trains transport auto parts and finished vehicles, lumber to build homes, coal to generate electricity and manufacture steel, food on grocery store shelves, grain for poultry and livestock farmers, and a host of other products essential to households, businesses, and industries.

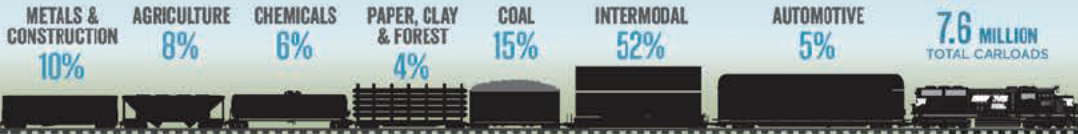

SUPPORTING ECONOMIES & COMMUNITIES

Economic Impact



Business Magnet

ATTRACTING ECONOMIC GROWTH



Extensive Network Reaches Over

50% OF U.S. POPULATION MANUFACTURING & ENERGY CONSUMPTION

Greener for the Globe

RAIL'S ENVIRONMENTAL ADVANTAGES



Safety is our No. 1 Priority

COMMUNITY EDUCATION & OUTREACH



WHEN YOU SEE TRACKS, THINK TRAIN!
EXPECT A TRAIN ON ANY TRACK AT ANY TIME.



Charitable Giving

NS FOUNDATION | 2013-2017



2017 DATA

CONNECT WITH NS



Norfolk Southern Corp. | www.nscorp.com
3 Commercial Place, Norfolk, Va. 23510
Report emergencies | 800-453-2530



TABLE OF CONTENTS

Section	Page
1.0 INTRODUCTION.....	1
2.0 PREVENTION.....	2
3.0 PREPAREDNESS.....	3
3.1 Coordination with Norfolk Southern Staff.....	4
3.2 Hazardous Material Traffic.....	5–6
3.3 Training and Exercises.....	7–8
Operations Awareness & Response (OAR).....	7
3.4 Local Norfolk Southern Rail Lines.....	8
3.5 Grade Crossings.....	8–9
3.6 Rail Crossing Locator Mobile Application.....	9
4.0 RESPONSE.....	10
4.1 Incident Levels (I, II, III).....	10
4.2 Unified Incident Command System.....	11
4.3 Notification Procedures.....	12
4.4 Norfolk Southern Response Resources.....	13
4.5 External Response Resources.....	13
4.6 Air Monitoring and Modeling.....	14
4.7 Local Resources.....	14
4.8 Special Considerations.....	15
4.8.1 Tunnels.....	15
4.8.2 Bridges.....	16
4.8.3 Radioactive.....	17
4.8.4 Pipelines.....	18
4.8.5 Other Railroad Right of Way Issues.....	18
4.8.6 Passenger Trains.....	18
4.8.7 Petroleum Crude Oil.....	19–20
4.8.8 Ethanol.....	21–22
4.8.9 Tank Cars.....	22–25
4.8.10 Tank Car Safety Features.....	26–27
5.0 RECOGNITION & IDENTIFICATION.....	28
5.1 Rail Tank Car Markings.....	28–29
5.1.1 Tank Car Specification Stencil.....	30
5.2 Shipping Papers.....	31
5.2.1 Shipping Paper Information.....	31

TABLE OF CONTENTS *(continued)*

5.2.2	Freight Train Consist.....	32
5.2.2a	Intermodal Train Consist.....	33
5.2.3	Position-In-Train Document.....	34
5.2.4	Rail Car Waybill Examples.....	35–36
5.3	Placarding and Hazard Classes.....	37
5.3.1	UN/DOT Hazard Classes.....	37
5.3.2	Placarding Chart.....	38–39
5.4	Emergency Response Guidebook.....	40
5.5	AskRail® Mobile Application.....	40–41
5.6	Association of American Railroads “Field Guide to Tank Cars”.....	42
6.0	APPENDICES.....	43
6.1	Railroad Safety Checklist (Guidelines).....	43–44
6.2	Railroad Equipment.....	45–51
6.2a	Railroad Intermodal Equipment.....	52
6.3	Tank Cars Valves & Fittings.....	53–58
6.4	Freight Railroad Security.....	58
6.5	NS Media Contacts.....	59
6.6	Online Sources of Information.....	60
6.7	Glossary of Chemical Terms.....	61–64
6.8	Acronyms.....	65–66

Hazardous Materials Pocket Response Guide

NS Hazardous Materials Group — Territory Map

Back Cover — NS Police Communications Center Number

EXHIBITS

EXHIBIT 1	Norfolk Southern Emergency Response Personnel.....	4
EXHIBIT 2	Norfolk Southern 2018 HazMat Traffic — Top 25 Commodities.....	5
EXHIBIT 3	Form to Request Hazardous Materials Flow Information.....	6
EXHIBIT 4	External Response Resources.....	13
EXHIBIT 5	Sample Norfolk Southern Freight Train Consist.....	32
EXHIBIT 6	Notice of Rail Cars & Intermodal Units Containing Hazardous Materials.....	34
EXHIBIT 7	Sample Norfolk Southern Loaded Waybill.....	35
EXHIBIT 7A	Sample Norfolk Southern Residue Waybill.....	36
EXHIBIT 8	UN/DOT Hazard Classes and Divisions.....	37

1.0 INTRODUCTION

The Norfolk Southern Emergency Response Planning Guide has been developed by Norfolk Southern Railway Company (Norfolk Southern) to assist local emergency response organizations in their efforts to plan for and respond to railway related incidents. It is also designed to be utilized as a reference resource, and hand-out to supplement training programs presented by Norfolk Southern to the emergency response community.

Because this Guide is designed to augment the local response plan(s), it is purposely brief to cover only the key information that would be needed by planners and response organizations if an incident involving Norfolk Southern should occur. The Guide is subdivided into four main sections, addressing Prevention, Preparedness, Response, and Recognition & Identification. Appendices are included which contain other pertinent railroad information. Important components of the Planning Guide include:

- Phone numbers and points of contact in the event of a Norfolk Southern related incident;
- Notification procedures in the event of a hazardous materials incident;
- Information on how to identify ownership of local rail lines;
- Information pertaining to monitoring and air dispersion modeling;
- Bridge and Tunnel incident considerations;
- Hazardous materials shipping paper descriptions and examples;
- Rail car placarding requirements and sources of additional information on hazardous materials and hazard identification;
- Additional resources available to Norfolk Southern and the Local Emergency Planning Committees (LEPCs) in the event of an incident;
- Training and emergency response exercise opportunities available from Norfolk Southern.

The information will assist local planners to prepare for and respond to any potential rail incident or emergency. This Plan is also designed to provide responders with accurate and efficient access to Norfolk Southern staff and resources, so that the necessary local and private resources can be engaged should the need arise.

2.0 PREVENTION

Accident and incident prevention are the primary focus and challenge of Norfolk Southern's hazardous materials program, with the goals of minimizing risks to the community, and maximizing employee and transportation safety and protection of the environment. These goals are accomplished throughout Norfolk Southern through a strict program of effective employee training, regulatory and rule compliance, and risk assessment. In addition, Norfolk Southern has a dedicated maintenance program designed to ensure ongoing proper maintenance of the operating system infrastructure. This includes frequent inspections and upgrades to rail equipment and track. In addition, Norfolk Southern coordinates with the shipper following any rail incident to ensure against reoccurrence of the situation and controlling factors.

Each day thousands of shipments of hazardous materials move by rail throughout the United States. While 99.998 percent of these shipments reach destination without issue, incidents involving rail cars do occur.

The U.S. Railroad industry had made great strides in improving the safety of the transportation of hazardous materials over the last three decades. The industry has taken many steps to improve its safety culture by taking initiatives such as daily job briefings, and communicating with dispatchers regarding the number of hand brakes applied, the tonnage and length of the train or vehicle, the grade and terrain features of the track, any relevant weather conditions, and the type of equipment being secured. Operating and maintaining equipment is only part of the task of ensuring the successful movement of freight from Point A to Point B. Railways maintain comprehensive security programs to protect goods from damage and theft. Measured in ton-miles, about 40 percent of U.S. freight volume moves by rail — more than any other transportation mode. Thanks to their significant investment in technology, processes, and infrastructure, railroads are ready to move even more of this freight securely and safely.

3.0 PREPAREDNESS

The primary goal of transporting hazardous materials is to move each and every shipment in a timely manner from origin to destination safely and without incident. In the event of a hazardous materials incident, the goal becomes to (1) effectively prevent injuries, (2) minimize property damage, and (3) safeguard against significant environmental impact.

Preplanning and preparedness are essential to achieving timely and effective incident response. An effective state of preparedness is accomplished through good emergency planning and training, comprehensive emergency response exercises, and the performance of regular evaluations of the effectiveness of response plans.

To better facilitate emergency preparedness activities with local communities, Norfolk Southern is an active participant in the TRANSCAER® Program (Transportation Community Awareness and Emergency Response). TRANSCAER® is a nationwide community outreach program designed to address community concerns about the transportation of hazardous materials through planning and cooperation. The program provides assistance for communities to develop and evaluate their emergency response plans for hazardous materials transportation incidents.

Norfolk Southern encourages local emergency management and response groups to incorporate this Guide into their own plans and take the opportunity to preplan at the Norfolk Southern facilities in their area of responsibility. Local emergency response personnel should familiarize themselves with the layout and operation of Norfolk Southern properties in their area.

For information about TRANSCAER® efforts at the local level, or to obtain information about training opportunities with Norfolk Southern for their community, local planners may contact the Norfolk Southern Safety & Environmental Department, Attention: System Manager, Hazardous Materials, 1200 Peachtree Street, NE - Box 13, Atlanta, GA 30309, email HMTraffic@nscorp.com.

3.1 Coordination with Norfolk Southern Staff

Norfolk Southern has a staff of hazardous materials and environmental professionals who can respond as necessary to any incident or emergency. These personnel are strategically located throughout the Norfolk Southern Operating System and are available to assist company personnel and emergency responders in the mitigation of emergency situations.

Our hazardous materials and environmental personnel have a variety of response tools and resources available for use in an emergency. These personnel will work with other company officials and the local incident command personnel to ensure safe and efficient handling of the incident.

A map of the Norfolk Southern Operating System, is included inside the back cover of this Guide, and contact information for NS Emergency Response staff is provided in **Exhibit 1**. NS Emergency Response staff can also be contacted 24 hours a day, 7 days a week, and 365 days a year by calling the NS Police Communications Center (PCC) at 1-800-453-2530.

EXHIBIT 1			
Norfolk Southern Emergency Response Personnel			
NORFOLK SOUTHERN HAZARDOUS MATERIALS GROUP			
Name	Title	Location	EMAIL
D. L. Schoendorfer	System Manager Hazardous Materials	Atlanta, GA	David.Schoendorfer@nscorp.com
R. C. Wood	Asst. System Manager Hazardous Materials	Atlanta, GA	Robert.Wood2@nscorp.com
NORTHERN REGION			
R. S. Deutsch	Regional Manager Hazardous Materials	Pittsburgh, PA	Scott.Deutsch@nscorp.com
C. D. Burch	Hazardous Materials Compliance Officer	St. Louis, MO	Cristofer.Burch@nscorp.com
S. C. Gould	Hazardous Materials Compliance Officer	Allentown, PA	Scott.Gould@nscorp.com
J. E. Lerner	Hazardous Materials Compliance Officer	Elkhart, IN	John.Lerner@nscorp.com
SOUTHERN REGION			
P. B. Williams	Regional Manager Hazardous Materials	Roanoke, VA	Paul.Williams2@nscorp.com
J. W. Hahn	Hazardous Materials Compliance Officer	Charlotte, NC	Justin.Hahn@nscorp.com
G. D. Rudner	Hazardous Materials Compliance Officer	Birmingham, AL	Glen.Rudner@nscorp.com
J. M. Bryan III	Hazardous Materials Compliance Officer	Chattanooga, TN	James.Bryan@nscorp.com
NORFOLK SOUTHERN ENVIRONMENTAL OPERATIONS GROUP			
Name	Title	Location	Office Phone
B. A. Naranjo	System Manager Environmental Operations	Atlanta, GA	404-582-3595
C. M. Hunsicker	Asst. System Manager Env. Operations	Pittsburgh, PA	412-893-7242
NORTHERN REGION			
T. S. Carpenter	Regional Manager Environmental Operations	Roanoke, VA	540-524-5183
W. B. Salley	Engineer Environmental Operations	St. Louis, MO	314-679-1853
R. J. Scoble	Engineer Environmental Operations	Bellevue, OH	419-483-1450
VACANT	Facilities Engineer Environmental Operations	Altoona, PA	814-949-1235
SOUTHERN REGION			
D. M. Patten	Regional Manager Environmental Operations	Chattanooga, TN	865-521-1594
Adam Motsinger	Engineer Environmental Operations	Charlotte, NC	704-378-3841
R. N. Williams	Engineer Environmental Operations	Atlanta, GA	404-529-2109

3.2 Hazardous Material Traffic

Data on the common types of hazardous materials being transported through local communities are useful for local emergency planners in developing effective and realistic emergency response plans. In general, the types of hazardous materials transported by rail through local communities do not vary significantly from the national average. The typical variance may be in the ordering of the “Top 25” products that are transported through various communities (**Exhibit 2**). To request Hazardous Material Traffic information for your jurisdiction, see **Exhibit 3**.

EXHIBIT 2 Norfolk Southern 2018 HazMat Traffic — Top 25 Commodities			
RANK	PROPER SHIPPING NAME	UN ID #	HAZARD CLASS
1	FAK* — Hazardous Materials	N/A	N/A
2	Alcohol, N.O.S.	UN 1987	3
3	Liquefied Petroleum Gas	UN 1075	2.1
4	Petroleum Crude Oil	UN 1267	3
5	Elevated Temperature Liquid	UN 3257	9
6	Sodium Hydroxide Solution	UN 1824	8
7	Butane	UN 1011	2.1
8	Env. Haz. Substance, N.O.S.	UN 3082	9
9	Hydrocarbons, Liquid, N.O.S.	UN 3295	3
10	Sulphur, Molten	NA 2448	9 / 4.1
11	Sulphuric Acid	UN 1830	8
12	Chlorine	UN 1017	2.3
13	Combustible Liquid, N.O.S.	NA 1993	CL
14	Isobutane	UN 1075	2.1
15	Hydrochloric Acid	UN 1789	8
16	Phosphoric Acid Solution	UN 1805	8
17	Propylene, Not Odorized	UN 1077	2.1
18	Phenol, Molten	UN 2312	6.1
19	Fuel Oil	UN 1993	CL
20	Ethyl Alcohol Solutions	UN 1170	3
21	Methanol	UN 1230	3
22	Sodium Chlorate	UN 1495	5.1
23	Potassium Hydroxide Solution	UN 1814	8
24	Carbon Dioxide, Refrigerated Liquid	UN 2187	2.2
25	Methyl Methacrylate Monomer	UN 1247	3

2018 — TOTAL HAZMAT SHIPMENTS = 600,982

Top 25% represents **81.21%** of total shipments

*FAK = Freight of **All Kinds**

3.2 Hazardous Material Traffic (continued)

The document below is available via download from the following site:

<http://www.joinnsoar.com/pdf/ns-hazmat-traffic-request-form.docx>

<http://www.joinnsoar.com/pdf/ns-hazmat-traffic-request-form.pdf>

EXHIBIT 3
Form to Request Hazardous Materials Flow Information



REQUEST FOR HAZARDOUS MATERIALS COMMODITY FLOW INFORMATION

Organization Requesting Information: _____

Contact Person: _____

Phone Number: _____

E-Mail Address: _____

Mailing Address: _____

(Street Address)

(City, State, Zip)

Geographical Description of Area for Study: _____

By signing below I acknowledge and agree to the terms set forth by Norfolk Southern Railway Company (NSRC) for use and dissemination of the NSRC Hazardous Materials Commodity Flow Information. NSRC considers this information to be restricted information of a security sensitive nature. I thus affirm and agree that the information provided by NSRC in this report will be used solely for and by bona fide emergency planning and response organizations for the expressed purpose of emergency and contingency planning. This information will not be distributed publicly in whole or in part without the expressed written permission of NSRC.

(Signature of person requesting commodity flow information)

Return completed form and a letter on official stationery requesting the information to:

HMTraffic@nscorp.com

(For NSRC Use Only)

Initials of person responsible for approval: _____ YES _____ NO Date: _____

Hazardous Materials Service Support:

Date Request Received: _____

Time Period Covered: _____

Date Report Sent: _____

Report sent via: E-Mail U.S. Mail

3.3 Training and Exercises

Operations Awareness & Response (OAR)

At Norfolk Southern, safety is our number one priority. Operation Awareness & Response (OAR), was launched in 2015 to educate the public about the economic importance of the safe movement of hazardous materials by rail and to connect emergency first responders in Norfolk Southern communities with information and training resources.

The goal of OAR is to strengthen relationships with the first responders across the NS network. Norfolk Southern has been providing safety training for emergency responders through community outreach programs such as TRANSCAER® for years. OAR will build on those efforts focusing on closer relationships with local and state agencies, increased training opportunities (classroom, web-based, and on-line resources), table-tops drills and participation in full-scale exercises, and providing better resources for emergency responders such as the AskRail® mobile app that allows the first responders to use their mobile phones to look up commodity and response information on shipments. The OAR program also includes a continued commitment to providing emergency responders high-level training at the Security and Emergency Response Training Center (SERTC) in Pueblo, Co. In April 2016, Norfolk Southern unveiled a brand new safety train, with a dedicated locomotive, specially equipped classroom box cars, and several tanks cars for additional hands-on training along our lines.

Join OAR

Sign up to receive the latest OAR news, training schedules, as well as industry emergency response updates. Don't worry: we won't send you endless emails, just a quarterly newsletter with all of the information included. Just go to: <http://www.joinnsoar.com/join-oar.html>.

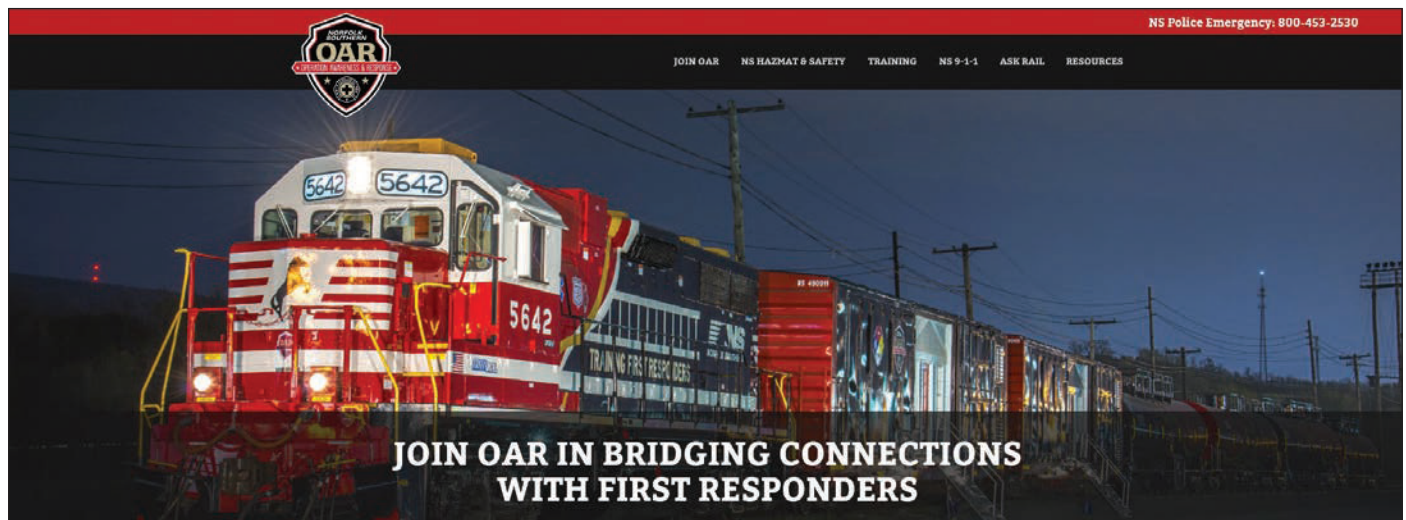

3.3 Training and Exercises *(continued)*

Regular training and emergency response exercises help to facilitate safe and efficient operations during response. Norfolk Southern has emergency response plans in place to control and remediate hazardous materials incidents and to minimize the damage caused by them. However, due to the nature of the railroad network, Norfolk Southern recognizes that local emergency response personnel, such as firefighters, Emergency Medical Technicians (EMTs), and police will most likely be the first to arrive at the scene of a hazardous materials incident. Therefore, the best developed plans in place throughout the Norfolk Southern Operating System will not be 100% effective unless an efficient incident response capability is maintained by local communities along the right-of-way.

In response to this need, Norfolk Southern is an active participant in the TRANSCAER® initiative. A portion of this program includes training for fire departments and other local emergency response organizations. Norfolk Southern works with Local Emergency Planning Committees (LEPCs) to coordinate participation in exercises and regularly conducts two levels of emergency preparedness exercises: tabletop exercises and full-scale exercises. Tabletop exercises are designed to have the participants practice problem solving, generate discussion, and resolve questions about handling an incident, through the tabletop analysis of various incident scenarios. Full scale exercises test emergency procedures using props and equipment in the field, and tests emergency response plans, via the enactment of a full response to a mock incident.

3.4 Local Norfolk Southern Rail Lines

It is important for local emergency planners to familiarize themselves with the local rail lines to know the ownership of the line and potential access routes for emergency response vehicles. As part of its grade crossing safety program, Norfolk Southern has posted a telephone hotline number (1-800-946-4744), along with the Federal Railroad Administration (FRA) unique Crossing Identification Number (shown on next page) at each Norfolk Southern crossing. This program allows people to report malfunctions in crossing safety devices to Norfolk Southern, but can also be used by emergency responders to identify Norfolk Southern rail lines in the event of a railroad incident. **A listing of the railroad crossings within a community can be obtained by contacting the Police Communications Center (PCC) (1-800-453-2530).**

3.5 Grade Crossings

All NS Railroad incidents, including situations that could affect **PUBLIC SAFETY** or the **SAFE MOVEMENT of TRAINS**, should be reported to the NS Railroad Police Communications Center located in Atlanta, GA at **1-800-453-2530** or the number noted on the Emergency Notification Sign. This could include a stuck or stalled vehicle on a crossing, accidents at or near a crossing, or any event or situation taking place in which close clearance of train traffic may be a safety factor. If a NS train needs to be stopped, remain on the line with the Police Communications Center (PCC) specialist until you are assured that this is accomplished. It is important to communicate to the NS Police the DOT crossing number (shown in bottom portion of sign) so that the specific road crossing can be quickly identified. Also, include the city, state and location of the incident.

3.5 Grade Crossings (continued)



Crossing Identification Number

At each PUBLIC road crossing there is a post mounted sign, as shown above, identifying the railroad name, the DOT crossing number, and the emergency telephone number. The reflective sign is the size of a vehicle license. Each PRIVATE road crossing is identified by the “Private Crossing” sign shown below on the right. The crossing identification number, the name of the railroad, and the emergency telephone number will be shown on a sticker, like the one shown in the center below, located on the reverse of the stop sign mounted above the “Private Crossing” sign.

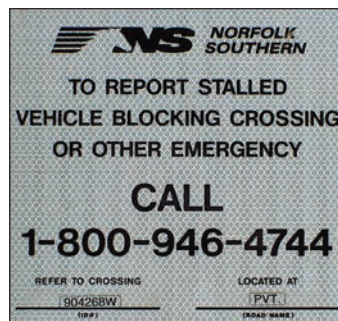

3.6 Rail Crossing Locator Mobile Application



The Rail Crossing Locator was developed by the Federal Railroad Administration to provide users with access to the highway-rail grade crossing database and map features from a mobile device. The tool allows users to locate crossings by USDOT Crossing ID, address or geo-location; access inventory records submitted by states and railroads; and view accident history. Users can also select from multiple base map features and identify railroad crossings by special characteristics. The information accessed in the mobile application is derived from the Safety Data website using information submitted by States and Railroads. While this is an effective tool, please use the Emergency Notification System (ENS) information and contact number during an emergency situation. The Crossing Locator App is currently available for your Apple and Android Devices.

<https://itunes.apple.com/us/app/rail-crossing-locator/id643005214?mt=8>

<https://play.google.com/store/apps/details?id=gov.dot.fra.RailCrossing>

4.0 RESPONSE

Norfolk Southern will respond to all known hazardous material incidents that occur in the course of transportation over the Norfolk Southern Railway system. Norfolk Southern's primary objectives at the scene of a hazardous materials incident are to:

- Protect life and health;
- Protect property and the environment;
- Cooperate with and assist governmental authorities; and
- Comply with local, state, and federal regulations.

4.1 Incident Levels (I, II, III)

Norfolk Southern has developed an internal incident level response system based upon the designation of hazardous materials incidents as either Level I (Low Hazard), Level II (Medium Hazard), or Level III (High Hazard) Incidents. Incident response Levels are determined on a variety of hazard assessment criteria, which include:

- Nature of Commodity or Hazard Class
- Leak Severity (Amount Released)
 - Location of Release (Valve versus Tank Failure)
 - Accessibility of Response Equipment to Leaking Car
 - Ease of Containment (Can Release Be Readily Stopped?)
- Potential Threat to Life or Safety (Including Public Drinking Water Supply)
- Fire/Explosion Potential
- Potential Environmental Impact to Water (Including Pipes, Drains, and Ditches), Land, and Air
- Container Integrity (Transloading Required?)
- Tank Car Derailment Status (Upright versus On Side)
- Oil Discharge (Locomotive Spills)

4.2 Unified Incident Command System

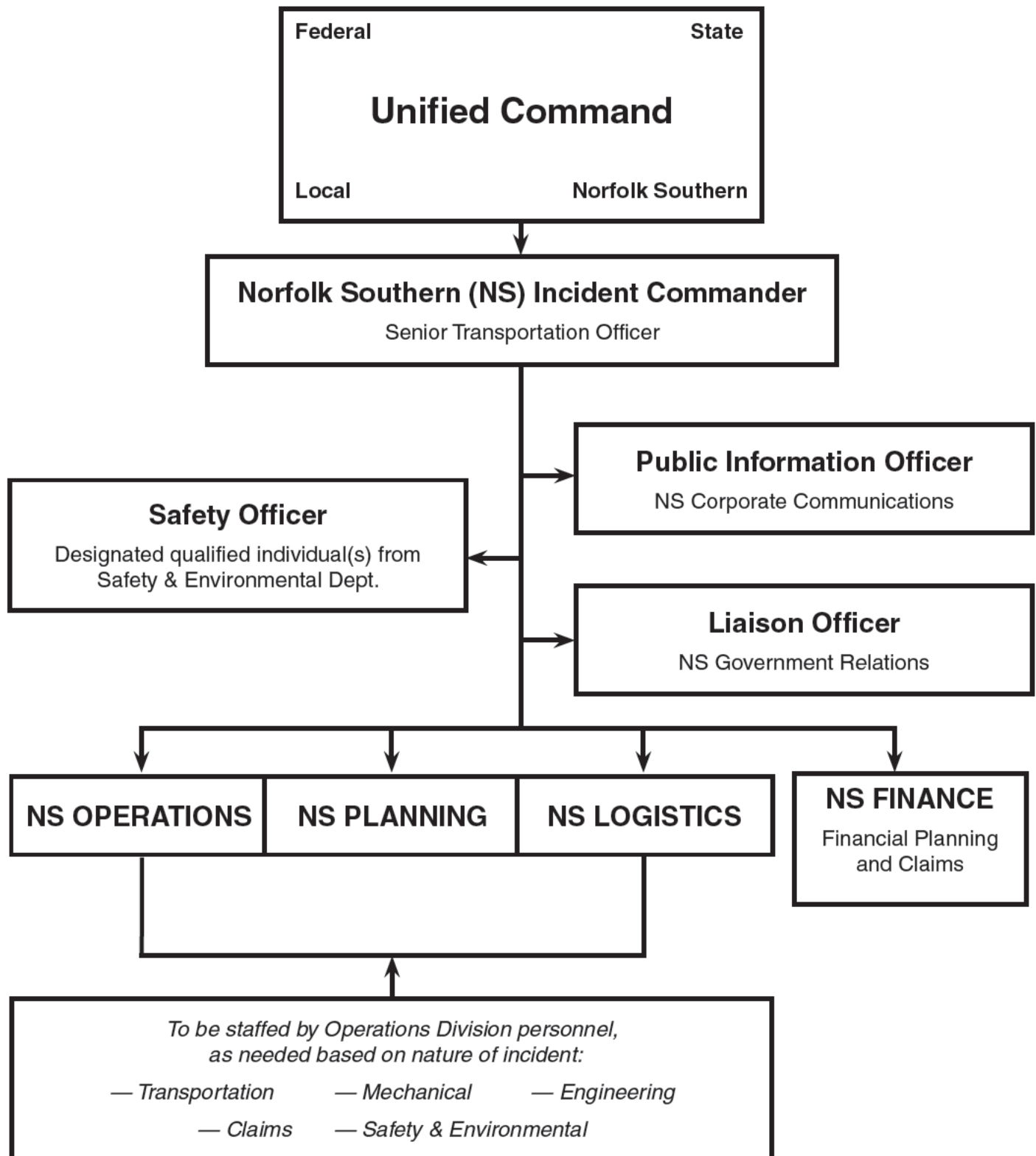

4.3 Notification Procedures

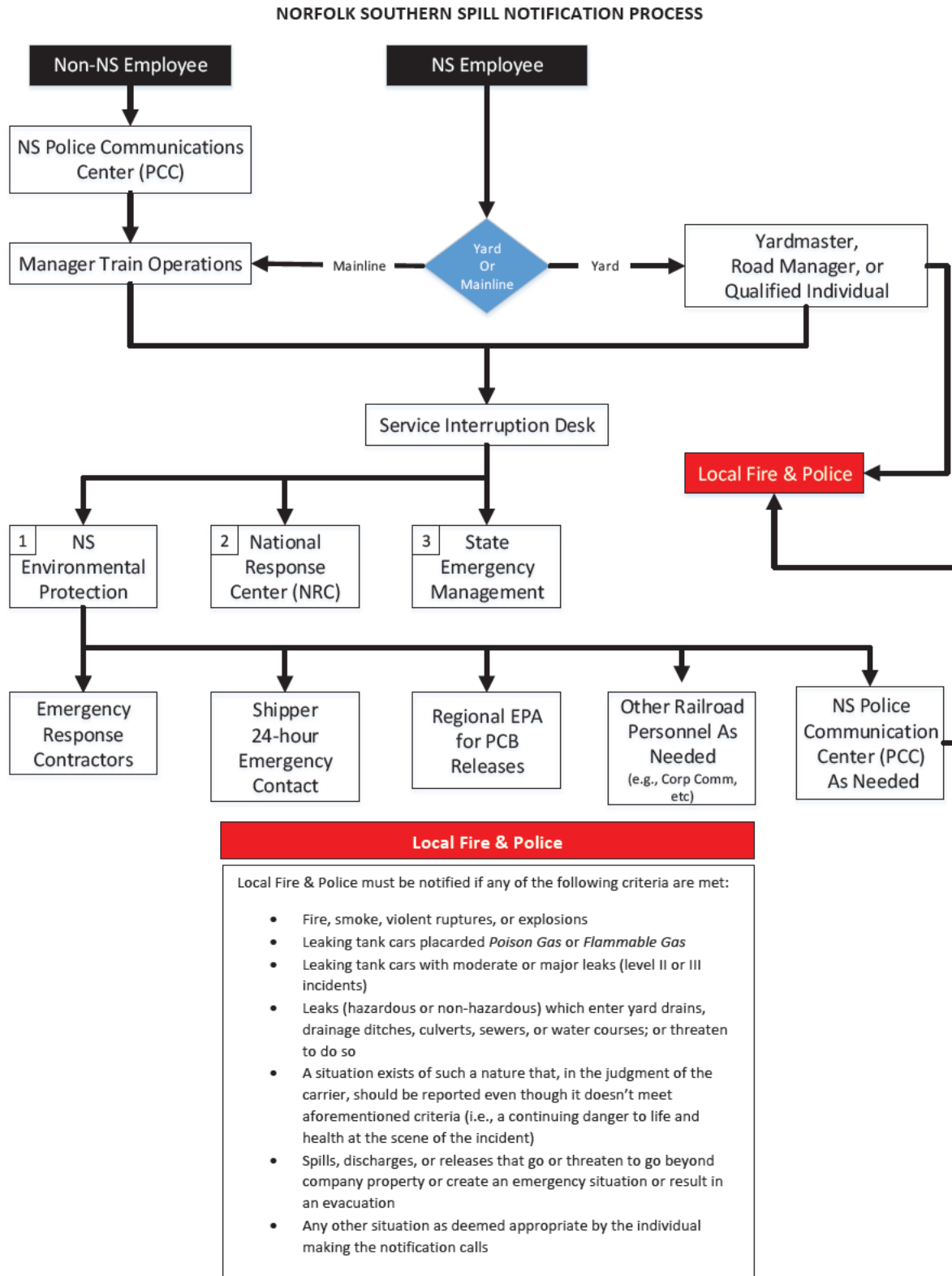

4.4 Norfolk Southern Response Resources

In the case of most derailments or spills, local responders do not have the equipment or expertise to handle large spill cleanup or railroad re-railing operations. Norfolk Southern recognizes its role in providing this specialized expertise and equipment to mitigate an incident. Norfolk Southern maintains standing contracts and agreements with various suppliers of these services.

Examples of these contractors are provided below.

- Railroad re-railing and wreck response contractors provide heavy equipment such as cranes, off track lifting equipment, heavy earth moving equipment, and the operators and ground crews to lift and re-rail damaged rail cars and locomotives.
- Emergency response (HazMat) contractors provide vacuum equipment, pumping equipment, and cargo tanks for the recovery of spilled products.
- Containers and heavy equipment are available for recovery of solid materials.
- Personnel are trained and equipped with all levels of protective equipment for operations in close proximity to spilled products, and leak and spill control equipment to contain product from leaking containers.
- Environmental recovery contractors provide technical expertise in the on-site remediation or removal of contaminated water, soil, or debris from the incident site.
- Industrial hygiene and public health contractors provide technical expertise and equipment to perform on-site and off-site soil, air, and water sampling. These contractors are also used to develop work and exclusion zones, and to document any exposures.

Norfolk Southern's internal resources include:

- Transportation, Mechanical, and Engineering Departments;
- Safety & Environmental Department;
- Railroad Police;
- Damage Prevention;
- Casualty Claims Offices;
- NS Law Department & Risk Management Department; and
- Public Relations Department.

4.5 External Response Resources

There are several private and governmental organizations capable of providing emergency response assistance in the event of emergencies involving hazardous materials.

EXHIBIT 4 External Response Resources	
Organization	Telephone Number
CHEMTREC	800-424-9300
U.S. Coast Guard, National Response Center (NRC)	800-424-8802
Nuclear Regulatory Commission	301-951-0550
Department of Energy	202-586-8100
U.S. Environmental Protection Agency	<By Region>

4.6 Air Monitoring and Modeling

In the aftermath of a chemical transportation accident, time and accurate information are critically important to saving lives and resources. To help incident commanders more competently assess the impact of a gas, water or land release on a community along Norfolk Southern lines, we use a network of specialized contractors with state-of-the-art plume modeling technology which is used to protect many of the world's largest industrial plants and their surrounding communities from the consequences of a chemical release.

Properly relating information to the general public is extremely important both before and after an emergency occurs. To assist in this effort, as well as gathering toxicological and chemical information, Norfolk Southern has retained the services of contractors with modeling experience to operate the new technology systems, if the need arises.

4.7 Local Resources

Norfolk Southern is a rail transportation company. In general, NS does not maintain resources such as fire-fighting or water supply equipment, emergency medical personnel or medical transport services, command posts and canteens, or large-scale communications equipment.

During an emergency operation, Norfolk Southern relies upon local emergency officials to provide these types of resources. The senior or designated Norfolk Southern official will coordinate with the local Incident Commander to obtain these local resources. Local resources will remain under the control of the local authority.

NS does maintain foam trailers strategically located across the system to assist when the need arises.

Norfolk Southern Foam Trailer Locations

Locations – UPDATED 01/2019

NS NORFOLK SOUTHERN
One line. Infinite possibilities.

4.8 Special Considerations

4.8.1 Tunnels

Special Considerations Unique to Tunnel Incidents

An incident in a tunnel involving a release of hazardous materials may create a greater risk than one in an open area. Toxic vapors are not readily dissipated and may displace air normally available for breathing. Fire may consume the air available for breathing leading to an oxygen deficient atmosphere.

Extreme care must be taken not to introduce additional hazards into the tunnel. The generation of a hazardous atmosphere from gasoline or diesel powered equipment, welding or burning fumes, chemical agents, and/or illuminating equipment may multiply the hazards already present.

Following is a list of additional factors to consider when responding to a rail incident inside a tunnel:

- Air monitoring — initial survey and continuous during response.
- Use of SCBA or respirator as determined by air monitoring results.
- Possible high temperatures due to presence of fire.
- Structural failure due to initial impact or fire/chemical damage.
- Tunnel lining type — stone, timber, steel, concrete or combination.
- Access points — portals, ventilation shafts, emergency exits, and inspection manways.
- Variation in track grade may produce a chimney effect.
- Tunnel length, curvature, gradient, height and width should be determined.
- Visibility may be limited or non-existent due to smoke, soot, chemical vapors.
- Communications may be difficult or impossible using radios or cell phones.
- Communication and lighting devices should be intrinsically safe.
- A personnel log must be kept of all people entering and exiting the tunnel.
- Ventilation units may be beneficial to remove fumes and vapors, however may also cause spreading of plume and fueling a fire.
- Foam generators may be an effective tool for fighting a tunnel fire.
- Determine presence of electric, gas, water, fiber optic and pipeline utilities.
- Best alternative may be to seal the tunnel and smother the fire.
- Communication between the ends of the tunnel, especially, to control entry.

Norfolk Southern has developed a Tunnel Emergency Action Plan which includes a detailed list with specifications for all tunnels on the system.

4.8.2 Bridges

Special Considerations Unique to Bridge Related Incidents

Response to emergency situations on elevated structures creates distinct challenges due to the possibility of excessive heights and lengths along with the various building materials used in the construction of a span. Open, closed or non-existent deck walkways must be navigated with extreme caution, as some structures are not designed for pedestrian traffic.

Railroad and emergency response personnel must consider employee and public safety first priority followed by environmental concerns.

Various possible scenarios may exist when responding to an incident involving an elevated structure. Emergency responders must consider a bridge may span over populated areas, streets or highways, waterways, or other railroad right of ways. Coordination with responders and railroad representatives concerning conditions at location of incidents is imperative.

If passenger rail service is involved, any injured persons or those in need of special assistance (the very young, old and/or disabled) should be located, and assistance shall be provided to the maximum extent possible under the given circumstances.

Following is a list of additional factors to consider when responding to a rail incident on an elevated structure:

- Determine accessibility issues and required special assistance.
- Consider need for the U.S. Coast Guard, helicopter, and high level rescue team.
- Consider impact on area dwellings and places of businesses.
- Consider closing and rerouting public and private access routes.
- Consider closing and rerouting navigable waterway traffic.
- Consider need for specially equipped boats, barges and emergency seafaring equipment.
- Consider need for downstream pollution control measures.
- Notify downstream communities of possible impacts.
- Notify other rail carriers whose movements may be impacted.
- Consider structural damage due to fire or derailed equipment.
- Identify critical systems (electric, communications, water, sewer, pipeline, etc.) present.
- Consider industrial hygiene issues (air monitoring, lead paint on steel structures).

Additional hazards associated with bridges may include areas with limited natural airflow. Airborne chemical concentrations may become elevated in these areas.

4.8.3 Radioactive

Special Considerations for Radioactive Material Incidents

Response to incidents involving radioactive material involves specialized equipment and trained personnel. Local emergency responder's primary consideration will be safely isolating the scene (controlling access) and preventing the spread of material to protect the public and minimize environmental impact.

This section describes initial response actions a first responder should take when arriving at the scene of a transportation incident involving radioactive material. The DOT Emergency Response Guidebook should be used to help make informed decisions about the types of hazards involved and the initial precautions to take in an emergency.

The U.S. Department of Energy will provide qualified emergency response personnel to provide assistance in minimizing hazards to the public from any radiological emergency regardless of magnitude or source. Their telephone number is (202) 586-8100. DOE uses a regional approach in providing assistance ranging from advice and consultation to actual response by specially equipped and trained teams of product specialists.

The following is a list of additional factors to consider when responding to a rail incident involving a radioactive material:

- Notify federal, state and local radiological control agencies.
- Do not enter the scene unless necessary to evacuate, administer first aid or rescue victims.
- Minimize the time in the incident area.
- Maintain as much distance as possible from the radioactive material package.
- Do not touch damaged packages or spilled material.
- Use available material for shielding whenever possible.
- Isolate the area to minimize exposure and reduce the spread of material.
- Alert local medical facilities that possible contaminated patients may be transported.
- Consider gross decontamination if a release has occurred.

Norfolk Southern has developed a Radioactive Shipment Emergency Action Plan which includes a detailed description of emergency response activities associated with an incident involving radioactive materials.

4.8.4 Pipelines

Many railroad rights-of-way contain underground pipelines which transport hazardous materials. These pipelines may be in a common right-of-way, in a parallel right-of-way, or actually cross the right-of-way and run under the tracks. Typical pipeline commodities include natural gas, liquefied petroleum gas, gasoline, kerosene, diesel fuel and other petroleum products.

A railroad incident which results in a derailment, requires heavy equipment operations in the right-of-way, or otherwise disturbs the right-of-way has the potential of damaging underground pipelines. Derailed cars and locomotives can directly impinge on a pipeline. Loads imposed on a pipeline from a derailed train or cleanup equipment, or striking the pipeline with digging equipment can result in immediate or future failure. Therefore, the presence of underground pipelines carrying hazardous materials must always be considered when responding to a rail incident.

Following is a list of additional factors to consider when responding to a rail incident which may be adjacent to a pipeline:

- Look for posted pipeline markers and warning signs.
- Identify and notify the pipeline owner/operator.
- Determine the commodity transported through the pipeline.
- Determine if the pipeline may have been breached.
- Look for pools of liquid, hissing sounds, odors indicating a release.
- Leave the area immediately if a release is discovered.
- Do not touch, breathe, or make contact with vapors or liquids.
- Do not light a match, start an engine, use a telephone, switch lights on/off.
- Notify local emergency responders through 911 system.
- Warn others in the area and restrict access.

Pipeline operators have their own emergency response protocols when notified of possible damage to one of their lines. Immediate identification and notification of the pipeline operator is very important to minimize any release.

4.8.5 Other Railroad Right of Way Issues

In addition to pipelines, there may also be fiber optic cables or other buried communication lines. These lines are usually marked with signs on posts. To be certain, always check with the railroad Engineering Department before digging on any right of way.

4.8.6 Passenger Trains

Special Considerations for Passenger Train Incidents

At many locations, passenger rail entities operate commuter and passenger trains on NS owned and operated tracks. When operating on NS, these trains are under the operational control of an NS train dispatcher. In the event of an emergency involving a passenger train, NS officials will coordinate with emergency response personnel, and the passenger rail entity officials to manage the passengers and mitigation of the emergency. Notifications of the incident will be essentially the same as for other emergency situations. NS, in conjunction with officials from the passenger railroad, will respond to an incident to provide needed services and resources.

Passenger service on NS is primarily operated by AMTRAK and any incidents should be reported immediately to the NS Police Communications Center at 1-800-453-2530. NS Police will contact AMTRAK.

Further information regarding AMTRAK and passenger train emergency planning is available online at www.amtrak.com.

4.8.7 Petroleum Crude Oil

SUMMARY OF CRUDE BY RAIL

Today, oil has been discovered and produced from the earth in large quantities by drilling companies using new technologies and then transported to refineries, where it is treated and transported once again to residential and industrial consumers. The primary method for transporting that crude oil is still pipeline; however, pipelines do not reach many of the refineries that take the product to the next step from the newly found and developed reserves. Therefore, the railroad industry has become a key transporter of the crude oil due to its flexibility in moving the product from the fields such as the Williston Basin (Bakken) and Niobrara (Colorado) to its final destination. The transportation of oil is a highly specialized operation which requires coordination among the various levels of the supply chain.

Railroads have continuously strived to further improve the safety of moving crude oil by rail. In 2011, the rail industry in coordination with shippers and tank car owners voluntarily adopted new standards for tank car construction that requires cars used to transport crude oil or ethanol to have thicker tanks, head shields, top fitting protection and bottom outlet handle protection. The rail industry formally petitioned federal regulators in 2011 to toughen existing standards for new tank cars which became HM 251 in 2015.

Crude Oil Basics



Crude can be a dark thick liquid, a light colored thin liquid, or somewhere in between. The vapors are heavier than air and will generally contain hydrogen sulfide (H₂S). Crude oil can have a petroleum-like odor or sulfur odor. The material is flammable.

Crude is usually referred to as “sweet” or “sour”. Sweet crude has less than 0.05% sulfur in it while sour crude will have a greater quantity. Sour crude tends to have the distinctive “rotten egg” smell because of the presence of hydrogen sulfide, which is a colorless, flammable, extremely hazardous gas. With continuous low-level exposure, or at high concentrations, a person loses his/her ability to smell the gas even though it is still present (olfactory fatigue). Therefore, do NOT rely on your sense of smell to indicate the continuing presence of hydrogen sulfide or to warn of hazardous concentrations. In addition, hydrogen sulfide is a highly flammable gas and gas/air mixtures can be explosive. Hydrogen sulfide is both an irritant and a chemical asphyxiant with effects on both oxygen utilization and the central nervous system. Effects can occur within a few breaths, and possibly a single breath.

4.8.7 Petroleum Crude Oil *(continued)*

Different crudes have a wide range of compounds and significant variations in BTU content. Flashpoint and boiling points vary, hence DOT packing group may vary by source / shipment. Flashpoint can be lower than gasoline or higher than diesel fuel. Crude transported in tank cars in the same train can originate from a variety of wells and the industry has found that characteristics of the crude in each car can vary greatly even when loaded at the same place. Even crude produced from wells within the same field can vary significantly. In the event of a release do not assume you know the properties, contact the shipper, get a Safety Data Sheet (SDS), read it carefully, conduct air monitoring and take the proper precautions.

“LIGHT” BAKKEN CRUDE

This crude is generally lighter crude both in color and specific gravity. It contains higher levels of benzene, butane, and light aromatics, which could build up vapor pressure in the tank car.

Flash point will be very low, comparable to gasoline in most cases. Material floats on water and will penetrate into ground readily.

“HEAVY” CANADIAN TAR SANDS CRUDE

This crude is heavier both in appearance and specific gravity. It contains lower levels of benzene and light ends, but more tars and related materials. Material is heated to load and unload from tank cars so it will flow.

Flash point will be higher range, comparable to diesel fuel in most cases but could be lower. Material penetrates the ground slowly. This crude will initially float but may form “tar balls” that sink.

Responding to Incidents

Refer to Guide 128 in the Emergency Response Guidebook.

Without limiting guidance in the ERG, the following are typical measures to be taken. Do not attempt offensive actions unless the resources are available to stop the flow of product, extinguish the fires, and maintain a foam blanket throughout the operation. **DO NOT RUSH IN!**

Tank cars of Bakken crude oil that have been exposed to pool fires have failed in less than 30 minutes. Firefighting operations should be done with remote operations using large volumes of water. Cool non-jacketed cars to prevent a sudden failure of the tank but take precautions to prevent, dam, or contain runoff. Non-jacketed cars generally fail before jacketed cars in pool fires, but conditions can vary. If no fire, monitor for LEL, VOC, H₂S, etc. before entry. Be aware vapors can travel and are heavier than air. They will flow to low lying areas and may accumulate in confined areas. Air monitoring is extremely important. Crude Oil is **FLAMMABLE** regardless of origin! Regardless of its viscosity, crude oil will flow downhill.

If crude oil is leaking from a tank car and NOT on fire, some factors to consider are:

- Conduct constant air monitoring for flammability and hazardous constituents. Are vapors accumulating in low lying areas?
- Can flow be stopped or directed? Be prepared to dam, dike, or divert flow.
- Are there drains or underground pathways that the crude can enter?
- Is there a waterway, creek, river, pond, etc., that the flowing material can reach?

A reference document for responding to crude oil derailments has been developed by DOT’s Pipeline and Hazardous Material Safety Administration (PHMSA). The Commodity Preparedness and Incident Management Reference Sheet for Petroleum Crude Oil can be found on PHMSA’s website at www.phmsa.dot.gov under Training and Outreach.

4.8.8 Ethanol

SUMMARY OF ETHANOL BY RAIL

Since the beginning of the twentieth century, the United States and the world have become a motorized society. Most families either own an automobile or rely on motorized transportation on a daily basis. For the past 100 years, the primary automotive fuel has been a byproduct of crude oil. Opposite from the European community, who focused on diesel engines for light-duty and passenger vehicles, the United States automobile industry, has predominantly produced gasoline-powered vehicles. The heavy-duty or off-road larger vehicles and equipment are generally being powered by diesel. Both gasoline and diesel are hydrocarbons (composed of hydrogen and carbon) derived from crude oil.

The nature and characteristics of hydrocarbon fuels are familiar to virtually everyone involved in fire protection today since gasoline and diesel are so widely used and incidents are common occurrences. However, as a result of public policy toward foreign oil supplies and other mandates, ethanol-blended fuels are a substantial component of the U.S. motor fuel market. Today, ethanol is blended into nearly all unleaded gasoline and is sold virtually from coast-to-coast and border-to-border. The bio-fuels industry, in general, is expected to significantly contribute to the nation's motor fuel supply. The ethanol industry has grown rapidly. Consumers in the United States use more than 140 billion gallons of gasoline per year, and nearly all of that is blended with ethanol.

History of Ethanol-Blended Fuels

Ethanol for use as a transportation fuel has been steadily growing since the 1980s. As production grew, ethanol was added to gasoline supplies to replace the octane enhancer's lead, benzene, toluene, and xylene as they were being removed from the gasoline supply due to toxicity concerns. The Clean Air Act of 1990 further increased the market share for ethanol-blended fuel due to mandated usage of oxygenated fuels in reformulated gasoline (RFG) in certain areas of the United States to help reduce carbon monoxide emissions. RFG refers to extensive changes in gasoline properties that reduce emissions of volatile and toxic organic compounds in ozone non-attainment areas. Fuel oxygenates, such as ethanol, add chemical oxygen to the fuel, which promotes more complete combustion thereby lowering CO emissions. Hydrocarbon exhaust emissions are also often reduced. Today, ethanol is the most widely used oxygenate for RFG. Ethanol has a blending octane of 113 and is widely used in creating regular octane gasoline from sub-octane base stocks or raising regular octane fuels to the mid-octane level. This addition of ethanol to gasoline to boost octane is an alternative to more severe refining operations making ethanol one of the most cost effective octane enhancers available to the refiner and blender today. As of 2015, the United States denatured fuel ethanol production capacity has grown to over 15 billion gallons.

EPA approved an increased concentration of ethanol, E15, for use in conventional gasoline powered vehicles in 2011. E15 can be used in light duty cars, trucks and SUVs model year 2001 and newer and for use in all flexible fuel vehicles (FFVs). Vehicles older than 2001, small engines, boats and motorcycles were not approved to use E15. Higher ethanol-blended fuels are growing in use. An example of this type of fuel is Ethanol Flex-Fuels (51–85% ethanol by volume).

4.8.8 Ethanol (continued)

Common Ethanol Blends and Ethanol-Blended Fuels

Ethanol — 100% volume is produced and marketed as undenatured/neutral, beverage alcohol. Denatured fuel ethanol is ethanol that has been denatured with 2–5% unleaded gasoline. This blend is also known as E95-E98 or fuel alcohol. Denatured fuel ethanol is one of the top freight rail commodities in the United States. Ethanol-blended fuels may include blends of gasoline and ethanol in any ratio, but at present there are three common ethanol-blended fuels. Most common is E10, a 90% gasoline/10% ethanol blend and available nationwide. EPA has approved E15, a 85% gasoline/15% ethanol blend for use in 2001 and newer vehicles. You will also find Ethanol Flex-Fuels in the market place which range from E51-E85, this fuel is sold for use in flexible-fuel vehicles (FFVs) only.

4.8.9 Tank Cars

Tank cars ordered after October 2011, known as CPC-1232 cars, have top valves in a strong protective housing (similar to a pressure car), 1/2-inch thick head shields (half height on non-jacketed cars, generally full height on jacketed cars), and tanks at least 1/2-inch on non-jacketed cars. The railroads and shippers voluntarily instituted these enhanced safety standards.

In 2015 the DOT mandated changes to the construction of rail tank cars that were transporting High Hazard Flammables. These flammables included most notably Crude Oil and Ethanol. The “high-hazard flammable trains” (HHFTs) were defined by the DOT as “a continuous block of 20 or more tank cars loaded with a flammable liquid or 35 or more tank cars loaded with a flammable liquid dispersed through a train.” The railroad industry developed a new specification tank car. The DOT-117 tank cars are designed primarily for the transportation of Class 3 (flammable liquid) materials. Specification DOT/TC-117A100W tanks are required to be constructed of AAR TC-128 Grade B, normalized carbon steel, with a minimum thickness of 9/16-inch. The tank test pressure is 100 psig, with a bursting pressure of 500 psig. Class-117 tank cars must have a tank head puncture resistance system consisting of full-height head shields at least 1/2-inch thick and a thermal protection system covered by a metal jacket of not less than 11 gauge (approximately 1/8-inch) thick (tank insulation is optional). A reclosing pressure relief device and top fittings must be protected. If equipped with a bottom outlet, the operating handle must be removed before movement, or the valve must be designed with a protection safety system to prevent unintended actuation during train accident scenarios.

Timeline for Retrofit of General Service Tanks Cars in U.S.			
Crude Oil Service		Ethanol	
Car Types	US Retrofit Deadline	Car Types	US Retrofit Deadline
Non-Jacketed DOT-111's	January 1, 2018	Non-Jacketed DOT-111's	May 1, 2023
Jacketed DOT-111's	March 1, 2018	Jacketed DOT-111's	May 1, 2023
Non-Jacketed CPC-1232's	April 1, 2020	Non-Jacketed CPC-1232's	July 1, 2023
Jacketed CPC-1232's	May 1, 2025	Jacketed CPC-1232's	May 1, 2025
Other Flammable Liquids - Packing Group I		Other Flammable Liquids - Packing Group II or III	
Car Types	US Retrofit Deadline	Car Types	US Retrofit Deadline
Non-Jacketed DOT-111's	May 1, 2025	Non-Jacketed DOT-111's	May 1, 2029
Jacketed DOT-111's	May 1, 2025	Jacketed DOT-111's	May 1, 2029
Non-Jacketed CPC-1232's	May 1, 2025	Non-Jacketed CPC-1232's	May 1, 2029
Jacketed CPC-1232's	May 1, 2025	Jacketed CPC-1232's	May 1, 2029

4.8.9 Tank Cars (continued)



Placards for Crude Oil



Placards for Ethanol

EXISTING DESIGN: DOT-111 rail tank car used to transport flammable liquids

- About 92,000 DOT-111s are in use; these must be retrofitted or replaced within eight years

- Railroads generally don't own tank cars; most are leased by oil companies or other firms moving products by rail

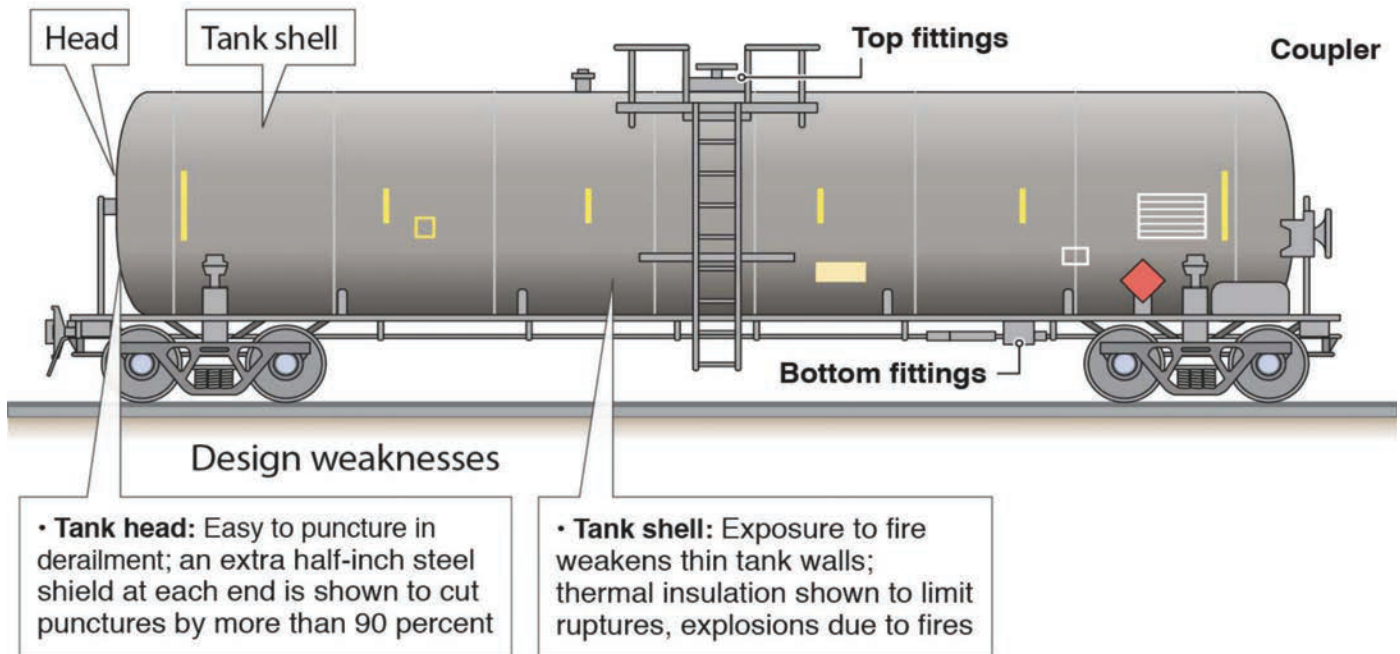

4.8.9 Tank Cars (continued)



Non-jacketed CPC-1232 tank car



Jacketed CPC-1232 tank car



Typical arrangement found in the protective housing on the CPC-1232 and DOT-117 cars.

4.8.9 Tank Cars (continued)

Designing a Safer Flammable Liquids Train

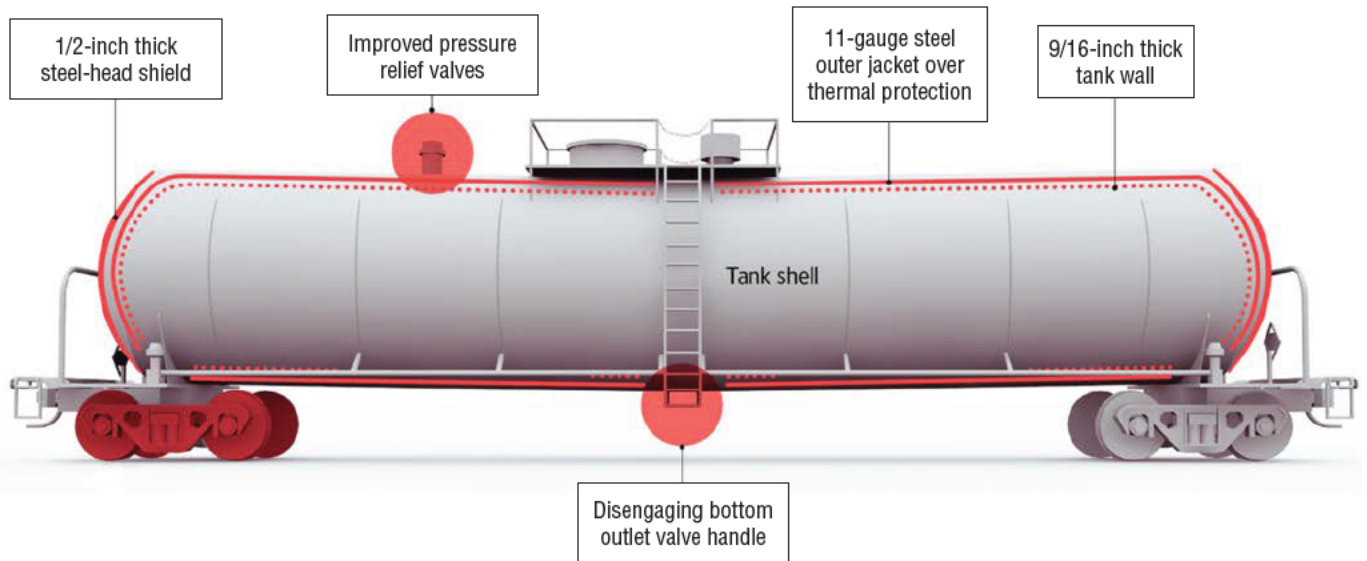

DOT-117 BOV valve and removable handle

4.8.10 Tank Car Safety Features

There are several safety features that are required on tank cars to protect the tank and its fittings from damage in the event of an accident.

Emergency responders should be aware of these safety features and how they can provide safety during an incident.

Double Shelf Couplers

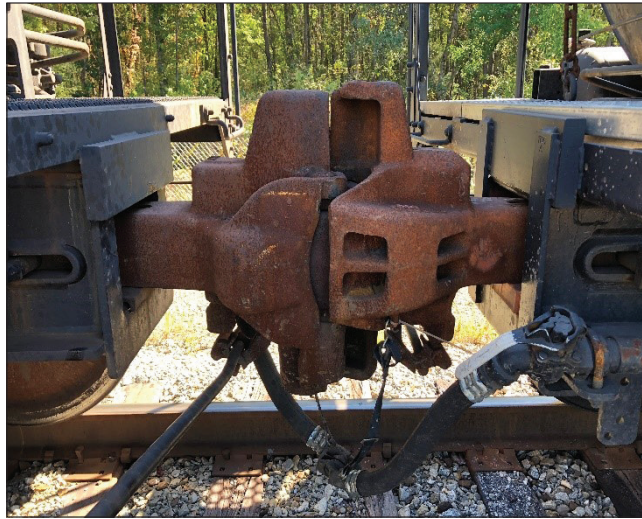

Tank cars are equipped with double shelf couplers which are designed to prevent an override situation causing head ruptures and punctures.

Head Shields



Tank cars that transport specified products must have a head shield that is intended to prevent the puncture of the tank head in the event of a derailment. This is accomplished by either an exterior mounted 1/2-inch plate at both ends of a car or a full head shield as part of the construction.

4.8.10 Tank Car Safety Features (continued)

Bottom Discontinuity Protection System (Skid Protection)



Bottom fittings protection may be accomplished by mounting the valve operating mechanism inside the tank and/or protective skids applied to the bottom of the tank. Continuation of the valve assembly below the tank shell or skid must be designed so that it will fail without damaging the valve, causing a release of product.

Top Fitting Protective Housing



Pressure tank cars are required to have a protective housing bolted to the pressure plate. Some general service tank cars may be equipped with a protective housing similar to those used on pressure tank cars to provide additional protection for the valves and fittings.

Pressure Relief Devices

PRDs are fittings designed to relieve the internal pressure within a tank car above a specified value that may result from abnormal conditions or from normal pressure increases during transportation (pressure relief device is synonymous with safety relief device).

In general, there are two categories of PRDs:

1. Reclosing devices, such as pressure relief valves (PRVs).
2. Non-reclosing devices (rupture disc devices) commonly called safety vents.

Thermal Protection

Pressure tank cars transporting Class 2 materials and general service DOT117 tank cars must be equipped with a thermal protection or insulation system that provides sufficient thermal resistance so that there will be no release of any lading, except through the PRD, when subjected to a pool fire for 100 minutes or a torch fire for 30 minutes.

5.0 RECOGNITION & IDENTIFICATION

5.1 Rail Tank Car Markings

Location of Key Stenciling

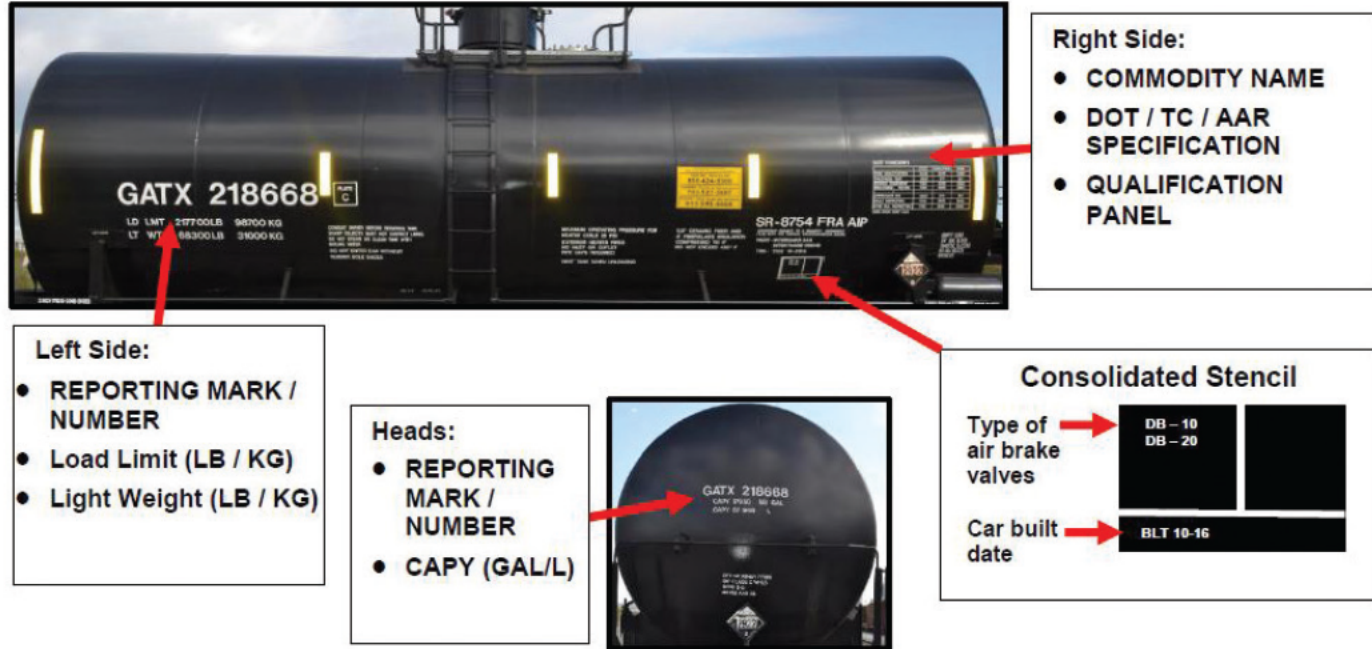

Photos courtesy of Norfolk Southern Railway Company

Rail Car Markings and Stenciling

Car Initial and Number (Reporting Mark) — Series of letters and numbers (4–7) used by the railroads to identify rail cars and their contents. This is similar license plate on a car. Letter prefix often indicates the owner/shipper of the car (e.g. TILX = Trinity). “X” indicates car is not owned by the RR. The reporting mark will be found on the side of the car on the left side and on the ends of the car. Additionally some shippers place markings on the bottom and top surface.

Commodity Name — The DOT requires that certain hazardous materials have their name stenciled on the side of the tank car.

Placards — Square-On-Point display that indicates the Primary and possibly Secondary hazard of the product present. The UN ID number may be displayed in the center of the placard or on an orange panel. The DOT Hazard Class number is displayed in the bottom corner of the placard.

Placards, Markings, and Identification Numbers

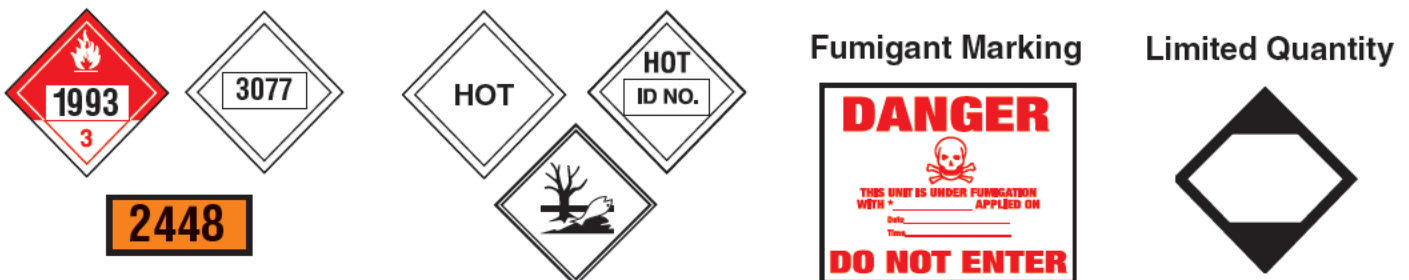

5.1 Rail Tank Car Markings (continued)

Tank Car Orientation

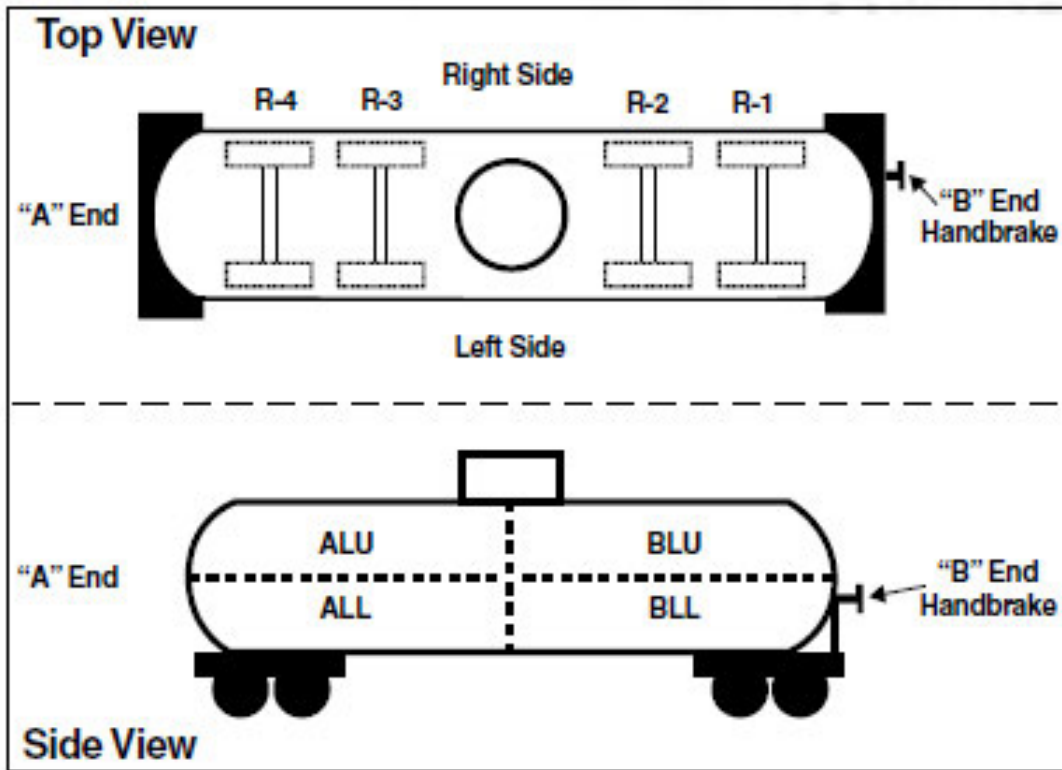

5.1.1 Tank Car Specification Stencil

The specification is stenciled on the side of car. A typical entry could be 111A100W1:

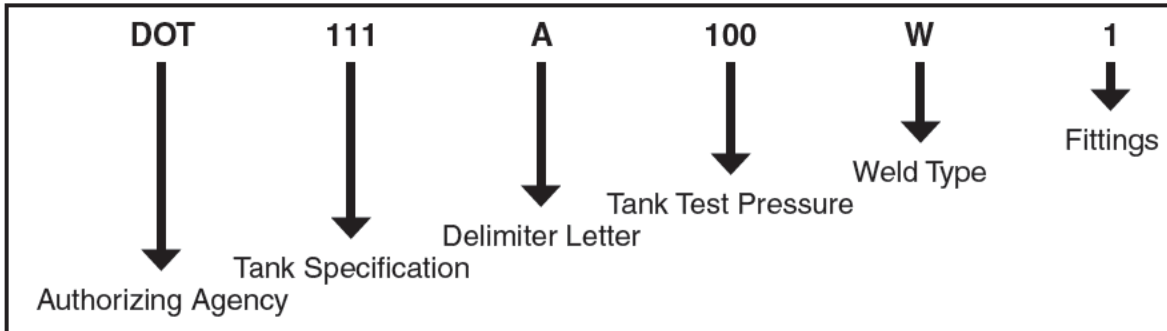

Authorizing Agencies

- AAR — Association of American Railroads
- CTC — Canadian Transport Commission
- DOT — US Department of Transportation
- TC — Transport Canada

Tank Specification

- General Service
111, 115, 117
- Pressure Tanks
105, 112, 114, 120

Delimiter Letter

- A — No special feature
- S — Equipped with head puncture protection
- T — Thermal protection & head protection
- J — Jacketed with Thermal protection & head protection
- P — Existing nonpressure tank car that meets performance standards for a Class-117A
- R — Existing nonpressure tank car that has been retrofitted to conform to the prescribed retrofit or Class-117A performance standards

Tank Test Pressure

Hydrostatic test pressure (not the Burst Pressure)

Weld Type

- W — Fusion Welded tank
- If constructed of other than carbon steel will be indicated by letters AL

Fittings

Indicates allowed fittings, linings, etc., as shown in chart:

Fittings	Insulation	Bottom Outlet	Bottom Washout	Other
1	Optional	Optional	Optional	
2	Optional	Prohibited	Optional	
3	Required	Optional	Optional	
4	Required	Prohibited	Prohibited	
5	Optional	Prohibited	Prohibited	Lined
6	Optional	Optional	Optional	
7	Optional	Prohibited	Prohibited	

5.2 Shipping Papers

During any incident involving the railroad it is extremely important to understand the paperwork is the key to identification. The Engineer and/or Conductor are required to have the shipping papers “Consist” available and also they must be updated when they pick up or drop off cars.

It is also important to understand that they cannot surrender these documents to the responder. They must maintain these documents and can only surrender them to the Senior Transportation Officer upon arrival at the incident. However, the responder may make copies and in today’s technology driven world, can take photographs using a smart phone or other device. Additionally copies can also be obtained from the NS Police Communication Center and NS HazMat personnel.

5.2.1 Shipping Paper Information

What They Tell You as an Emergency Responder

Car Initials and Numbers: One of the most important pieces of information to obtain in order to access information on the car’s contents.

Load or Empty: The shipping paper will indicate if the car is loaded or contains a residue.

Shipper and Consignee: Shipper area will show who shipped the car and where it originated; Consignee area will show who is receiving the shipment and the destination.

ID Number: Indicates the 4-digit UN (United Nations) or NA (North American) identification number.

Proper Shipping Name: DOT name of the hazardous material.

Hazard Class: Shows the appropriate hazard class or division number of product (refer to **Exhibit 8**). A secondary hazard class may be shown for Domestic moves, however they are required internationally

Packing Group: A grouping of hazardous materials indicating relative severity of a material within its hazard class. Required except for classes 2 or 7 or ORMD’s. PG I or I shown using roman numerals, great danger; PG II or II, medium danger; PG III or III minor danger.

Quantity: The shipping paper will indicate how much product is being shipped, if loaded.

Emergency Response Phone Number: 24 hour phone numbers supplied by the shipper.

Toxic Inhalation Hazard/Poison Inhalation Hazard (TIH/PIH): indicates certain gases or liquids that cause health problems if inhaled.

Hazard Zone: Applies to TIH/PIH materials. Zones are A through D, with A being most toxic

Reportable Quantity: The letters “**RQ**”, where required indicate that the material is also classified as a hazardous substance and that a release of the hazardous material, over a specified amount, necessitates notifying the National Response Center.

Standard Transportation Commodity Code (STCC): A number assigned by railroads for the specific product being shipped. STCC’s begin with the numbers “49” for HazMat or “48” for Haz Waste. These STCC’s are often referred to as Hazardous Materials Response Codes (HMRC).

Marine Pollutant: Release of the product into a waterway will harm the environment.

Limited Quantity: LTD QTY, a product with a labeling and packaging exception.

5.2.2 Freight Train Consist

EXHIBIT 5
This Train Contains The Following "Key Train" Hazardous Materials Loads:

	IN	SET-OUT/PICK-UP
	TRAIN	
* POISON INHALATION HAZARD COMMODITIES	0	
* OTHER LOADED HAZMAT CARS OR IM TANKS	2	
* TOTALS	2	

CARS IN THIS CONSIST COUNT FROM FRONT TO REAR

HAZARDOUS CONSIST FOR TRAIN 41KB430
 DEPARTED KANKAKEE IL

PAGE 01 OF ____

PRINTED 02/01/2019 11:00 AM

ON DUTY: _____

OFF DUTY: _____

CARS SET OUT

SEQ	INIT	NUMBER	L/E	DEST/OFFJCT	NXRD	TON	CONSIGNEE	STCC	TYPE	TIME	TRACK	LINE
000	NS	E08578	E			000						
000	NS	E08026	E			000						
001	CNWX	111804	L	TOLEDO OH		109	ANDERSON	0113310	C113			
002	CNWX	110103	L	TOLEDO OH		112	ANDERSON	0113310	C113			
003	CR	369236	L	TOLEDO OH		104	ACME	2099511	R410			
004	CR	369254	L	TOLEDO OH		098	ACME	2099511	R410			
005	CR	369171	L	TOLEDO OH		102	ACME	2099511	R410			
006	CR	369319	L	TOLEDO OH		104	ACME	2099511	R410			
007	AM	002517	L	TOLEDO OH		101	ACME	2099511	A346			
008	NS	463472	L	TOLEDO OH		124	BESTPROD	2621115	A632			

UNLOAD AS PLACARDED

PLACE FOR UNLOADING AS PLACARDED.

009	GATX	016254	L	TOLEDO OH		135	MESTERESIN	4921598	T106			
-----	------	--------	---	-----------	--	-----	------------	---------	------	--	--	--

ENDORSED AS HAZARDOUS MAT

1 TNK

 * HAZARDOUS *
 * MATERIALS *

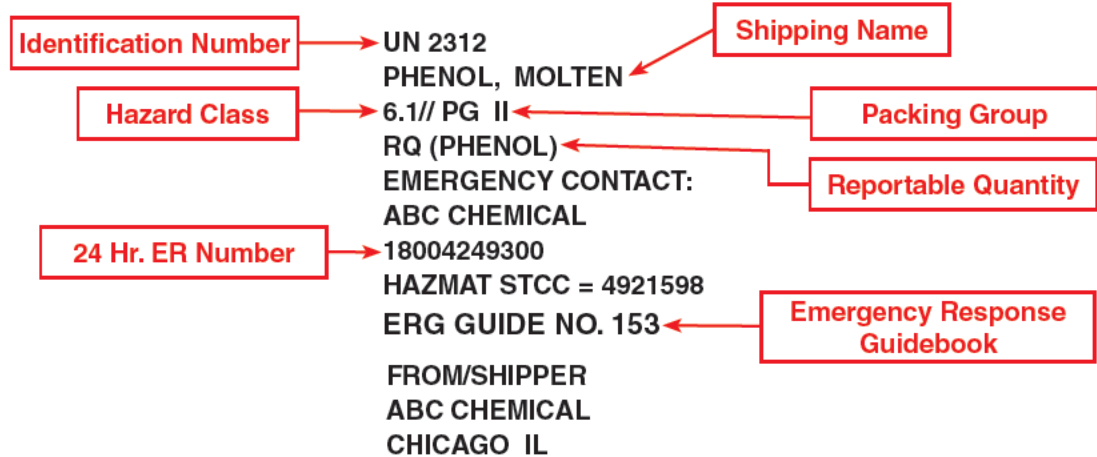

5.2.2a Intermodal Train Consist

Because of the trailers/containers on the rail cars, the Train Consists for Intermodal Trains are slightly different from other freight trains. The trailers or containers are listed after the rail car.

Position in Train	Rail Car	
Trailer		

<p>005 TTAX 556852 L ATLANTA GA 093 UNIPARSE 4950150 Q752 _____</p> <p>ENDORSED AS HAZARDOUS MAT</p> <p>***** 0</p> <p>* HAZARDOUS * * MATERIALS * TOFC FLATCAR</p> <p>***** SEE INDIVIDUAL WAYBILLS</p> <p>HAZMAT STCC: 4950150</p> <p>TO/CONSIGNEE: FROM/SHIPPER: UNITED PARCEL SERVICE INC UNITED PARCEL SERVICE INC ATLANTA GA HODGKINS IL</p>	<p>UPSZ 871373 L ATLANTA GA 022 UNIPARSE 4950150 Z249 _____</p> <p>ENDORSED AS HAZARDOUS MAT</p> <p>***** 1 TRL</p> <p>* HAZARDOUS * * MATERIALS * 4 PCS 16 LT UN 1262 OCTANES 3//PGII</p> <p>EMERGENCY CONTACT: CONTRACT# 000ABC (800) 424-9300</p> <p>1 PCS 12 QT UN 1133 ADHESIVES 3//PGII</p> <p>EMERGENCY CONTACT: ABQ Chemical 000ABC (800) 424-9300</p> <p>1 PCS 15 LT UN 1219 ISOPROPANOL 3//PGII</p> <p>EMERGENCY CONTACT: XYZ Distiller (800) 255-3924</p>	<div style="border: 1px solid red; padding: 5px; width: fit-content;"> <p>Three different commodities in this trailer.</p> </div>
<p>TO/CONSIGNEE: UNITED PARCEL SERVICE HODGKINS IL</p> <p>REAZ 216654 L ATLANTA GA REDZ 234512 L ATLANTA GA TIPZ 227798 L ATLANTA GA UPSU 621226 L ATLANTA GA</p>	<p>FROM/SHIPPER: UNITED PARCEL SERVICE INC</p> <p>022 UNIPARSE 4611110 Z276 _____ 022 UNIPARSE 4611110 Z256 _____ 022 UNIPARSE 4611110 Z278 _____ 022 UNIPARSE 4611110 U249 _____</p>	

Four other trailers and containers on same flat

5.2.3 Position-In-Train Document

EXHIBIT 6 Notice of Rail Cars & Intermodal Units Containing Hazardous Materials											
Train #:		41KB430		Location:		KANKAKEE IL		02/01/2019		11:00AM	
<p>The following rail cars & intermodal units containing hazardous materials are located in your train. They must be positioned in your train in accordance with the train placement chart. Revision columns are to be used to make placement changes en route.</p>											
INIT	NUMBER	L E	CONTAINER INIT NUMBER		L E	COMMENT	I.D. NO.	TRAIN POSITION	REVISION 1ST 2ND 3RD		
GATX	016254	L	_____	_____	—	_____	2312	009	_____	_____	_____
LTCX	001610	E	_____	_____	—	_____	1951	016	_____	_____	_____
CELX	023148	E	_____	_____	—	_____	1173	021	_____	_____	_____
UTLX	200801	E	_____	_____	—	_____	1301	022	_____	_____	_____
UTLX	201183	E	_____	_____	—	_____	1301	023	_____	_____	_____
UTLX	202872	L	_____	_____	—	_____	1090	028	_____	_____	_____
<p><i>Below reflects changes after a delivery to an industry:</i></p>											
INIT	NUMBER	L E	CONTAINER INIT NUMBER		L E	COMMENT	I.D. NO.	TRAIN POSITION	REVISION 1ST 2ND 3RD		
GATX	016254	L	_____	_____	—	_____	2312	009	_____	_____	_____
LTCX	001610	E	_____	_____	—	_____	1951	016	_____	12	_____
CELX	023148	E	_____	_____	—	_____	1173	021	_____	17	_____
UTLX	200801	E	_____	_____	—	_____	1301	022	_____	18	_____
UTLX	201183	E	_____	_____	—	_____	1301	023	_____	19	_____
UTLX	202872	L	_____	_____	—	_____	1090	028	_____	23	_____

5.2.4 Rail Car Waybill Examples

**EXHIBIT 7
Loaded Waybill**

```

***** 555 - NORFOLK SOUTHERN - 555
* HAZARDOUS * HAZARDOUS SER 2074567066 IMAGE ID E9083115492283
* MATERIALS * * MEMO WAYBILL *
***** EDI-BOL MERCHANDISE WAYBILL
***** REPRINT*****
AOC 02/01/2019 03:06A W01

GATX 16254 T135 PLATE B CAR 66'03" 02/01/2019 394277
T
B

72712 TOLEDO OH 11089 CHICAGO IL
55555 ATLANTA AOC GA
NS S 802-0708 1250610019
PBW CHEMICAL
855 2ND STREET S W
SUITE 3990
CHICAGO IL

DLS RESINS 02-01-19 00:06 0005170
1801 E. SEPULVEDA BLVD.
TOLEDO OH

1250610019
PBW CHEMICAL
855 2ND STREET S W
SUITE 3990
CHICAGO IL

SEAL 1 - 89922

PREPAID NO SHIPPER WEIGHT AGREEMENT

240,798
105,400
135,398

4921598

1CAR OSA 149398 MEMO WAYBILL
UN 2312 REVENUE WAYBILL WILL BE MAILED
PHENOL, MOLTEN TRANSMITTED TO DESTINATION ROAD
6.1//PG II BY ATLANTA REVENUE ACCOUNTING OFC
RQ (PHENOL)
ERG 153
(CARBOLIC ACID)
EMERGENCY CONTACT:
ABC CHEMICAL
8004249300
HAZMAT STCC=4921598
GATX 16254 GAL CP= 24698
    
```

5.2.4 Rail Car Waybill Examples (continued)

**EXHIBIT 7A
Residue Waybill**

***** 555 - NORFOLK SOUTHERN - 555
 * HAZARDOUS * HAZARDOUS SER 2068132154 IMAGE ID D01599H23Q3700
 * MATERIALS *

EMPTY WAYBILL
 *****REPRINT*****

GATX 16254 T135 PLATE B CAR 66'03" 02/01/2019 394277
 T
 B

VERSION 1 EDI

72712 TOLEDO OH 11089 CHICAGO IL
 55555 ATLANTA AOC GA
 S 802-0708 1250610019

NS PBW CHEMICAL
 855 2ND STREET S W
 SUITE 3990
 CHICAGO IL

02-01-19 00:06 0005170

DLS RESINS
 1801 E. SEPULVEDA BLVD.
 TOLEDO OH

1250610019

SEAL 1 - 89922 PBW CHEMICAL
 855 2ND STREET S W
 SUITE 3990
 CHICAGO IL

PREPAID NO

SHIPPER WEIGHT AGREEMENT

240,798
 105,400
 135,398

4921598

1CAR OSA

RESIDUE LAST CONTAINED
 UN 2312
 PHENOL, MOLTEN
 6.1//PG II
 RQ (PHENOL)
 ERG 153

(CARBOLIC ACID)

EMERGENCY CONTACT:
 ABC CHEMICAL
 8004249300
 HAZMAT STCC=4921598
 GATX 16254 GAL CP= 24698

5.3 Placarding and Hazard Classes

















The Code of Federal Regulations (CFR), 49 CFR Part 172, prescribes that square-on-point shaped placards must be placed on the outside of certain bulk container rail cars carrying hazardous materials, or residues of such materials. Placards must also be placed on the exterior of some intermodal containers carrying amounts of hazardous materials in excess of certain regulatory thresholds. Placards can tell the responder the DOT hazard class involved and thus provide a general idea of the hazards present and preliminary response requirements. Keep in mind that many materials possess characteristics of more than one hazard class, and therefore hazard class information should generally not be used independently. Check shipping paper for more details.

5.3.1 UN/DOT Hazard Classes

























Hazardous materials are classified according to their chemical and/or physical properties. There is one worded class and nine numeric classes, some of which may be divided into divisions. A hazardous material is assigned to only one class, even if it meets the definition of more than one hazard class. **Exhibit 8** lists the hazard classes and divisions.

EXHIBIT 8	
Hazard Classes and Divisions	
Numbered Classes and Divisions	
1 — Explosives	<ul style="list-style-type: none"> 1.1 — Explosive with mass explosion hazard 1.2 — Explosive with projection hazard 1.3 — Explosive with predominantly fire hazard 1.4 — Explosive with no significant blast hazard 1.5 — Very insensitive explosive; blasting agent 1.6 — Extremely insensitive detonating substance
2 — Gases	<ul style="list-style-type: none"> 2.1 — Flammable gas 2.2 — Non-flammable, nonpoisonous (nontoxic) compressed gas 2.3 — Gas poisonous (toxic) by inhalation
3 — Flammable Liquids	
4 — Flammable Solids and Reactive Solids/Liquids	<ul style="list-style-type: none"> 4.1 — Flammable solid 4.2 — Spontaneously combustible material 4.3 — Dangerous when wet material
5 — Oxidizers and Organic Peroxides	<ul style="list-style-type: none"> 5.1 — Oxidizer 5.2 — Organic peroxide
6 — Poisonous (Toxic) Materials and Infectious Substances	<ul style="list-style-type: none"> 6.1 — Poisonous (toxic) material 6.2 — Infectious substance
7 — Radioactive Materials	
8 — Corrosive Materials	
9 — Miscellaneous Hazardous Materials	
Worded Classes	
Combustible Liquid	

5.3.2 Placarding Chart

Placards for Hazardous Materials by Hazard Class		
Class 1 (Explosives)		
 Division 1.1 (Explosive with Mass Explosion Hazard)	 Division 1.2 (Explosive with Projection Hazard)	 Division 1.3 (Explosive with Predominantly a Fire Hazard)
 Division 1.4 (Explosive with no Significant Blast Hazard)	 Division 1.5 (Very Insensitive Explosive)	 Division 1.6 (Extremely Insensitive Explosive)
Class 2 (Gases)		
 Division 2.1 (Flammable Gas)	 Division 2.1 (Flammable Gas in cryogenic form in DOT-113 Tank Car)	 Division 2.2 (Non-flammable Gas)
 Division 2.3 Zone A (Poison Gas)	 Division 2.3 Other than Zone A (Poison Gas)	<p style="text-align: center;">International Placard</p> <div style="display: flex; justify-content: space-around;">   </div> <p>NOTE: The word "TOXIC" can be used in place of the word "POISON."</p> <p>May appear in conjunction with U.S. "POISON" GAS Placard (INHALATION HAZARD CLASS 2) on Canadian or International Shipments.</p>
 Oxygen	 Anhydrous Ammonia Canadian Only	
Class 3 (Flammable Liquids)	Class 3 (Combustible Liquids)	
 Class 3 (Flammable Liquid)	 Class 3 (Combustible Liquid)	

5.3.2 Placarding Chart (continued)

Placards for Hazardous Materials by Hazard Class		
Class 4 (Flammable Solids & Reactive Solids/Liquids)		
  Division 4.1 (Flammable Solid)	  Division 4.2 (Spontaneously Combustible)	  Division 4.3 (Dangerous When Wet Material)
Class 5 (Oxidizers & Organic Peroxides)		
  Division 5.1 (Oxidizer)	  Division 5.2 (Organic Peroxide)	
Class 6 (Poisonous Materials)		
  Division 6 1 Zone A [Poison or Toxic Inhalation Hazard (PIH or TIH)]	  Division 6.1 Zone B [Poison or Toxic Inhalation Hazard (PIH or TIH)]	
  Division 6.1 PGI [Other than Poison or Toxic Inhalation Hazard (PIH or TIH)], PGII, or PGIII	 Division 6.1 PGIII	NOTE: The word "TOXIC" can be used in place of the word "POISON."
Class 7 (Radioactive Materials)  Class 7 (Radioactive Material)	Class 8 (Corrosive Materials)   Class 8 (Corrosive Material)	Class 9 (Miscellaneous Hazardous Materials)   Class 9 (Miscellaneous Hazardous Material)
Mixed Load	Limited Quantity Marks	Marine Pollutant Marking
 U.S.	 Canadian	

5.4 Emergency Response Guidebook

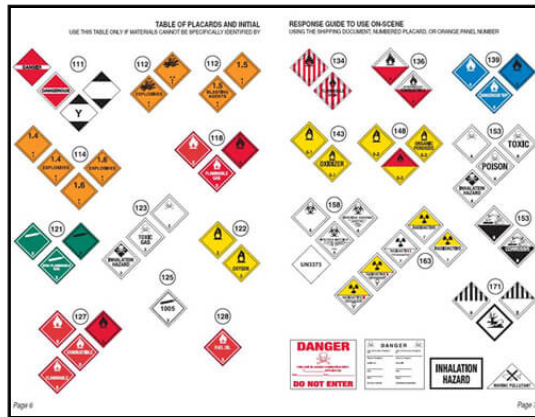
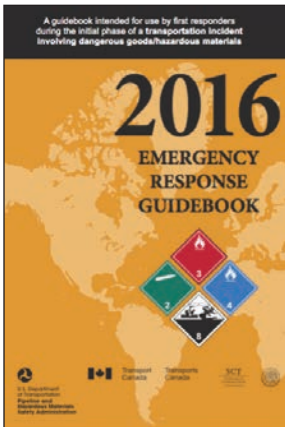

ID No.	Guide Name of Material	ID No.	Guide Name of Material
1205 128	Kerosene	1262 128	Isobutane
1206 127	Ketones, liquid, n.s.s.	1262 128	Octanes
1229 131	Mercaptan mixture, liquid, flammable, poisonous, n.s.s.	1263 128	Paint (flammable)
1229 131	Mercaptan mixture, liquid, flammable, toxic, n.s.s.	1263 128	Paint (oxidizing material) (flammable)
1229 131	Mercaptan, liquid, flammable, poisonous, n.s.s.	1264 128	Paraldehyde
1229 131	Mercaptan, liquid, flammable, toxic, n.s.s.	1265 128	Isopentane
1229 131	Mercaptan, liquid, flammable, toxic, n.s.s.	1265 128	n-Pentane
1229 128	Methylacrylate	1265 128	Pentanes
1310 131	Methanol	1305 127	Petroleum products, with flammable solvents
1320 131	Methyl alcohol	1307 128	Petroleum crude oil
1321 128	Methyl acetate	1308 128	Petroleum distillates, n.s.s.
1331 131	Methylmethyl acetate	1309 128	Petroleum products, n.s.s.
1334 127	Methylol	1310 128	Oil, petroleum
1335 128	Methylamine, aqueous solution	1310 128	Petroleum oil
1337 128	Methylsilylate	1312 128	Pinol oil
1339 128	Methylchlorosulfonate	1314 128	n-Propanol
1339 131	Methylchlorosulfonate	1314 128	Normal Propyl alcohol
1340 128	Methylchlorosulfonate	1314 128	Propyl alcohol, normal
1343 128	Methyl formate	1315 128	Propionalsdehyde
1343 131	Methyl formate	1316 128	n-Propyl acetate
1344 127	Methyl isobutyl ketone	1317 128	Monopropylene
1344 127P	Methyl isopropyl ketone, stabilized	1317 128	Propylamine
1344 128	Methyl propyl ketone	1318 128	1-Chloropropane
1344 127	Methyl propyl ketone	1319 128	Propyl chloride
1345 128	Methyl ethyl ketone	1319 128	1,2-Dichloropropane
1346 128	Methyl propyl ketone	1319 128	Dichloropropane
1347 128	Methyl methacrylate monomer, stabilized	1319 128	Propylene dibromide
1347 128	Methyl methacrylate monomer, unstabilized	1320 127P	Propylene oxide
1348 127	Methyl methacrylate, stabilized	1321 129	Propyl formate
1348 127	Methyl methacrylate, unstabilized	1322 129	Pyridine
1349 127	Nitromethane	1326 127	Stearic acid

The Emergency Response Guidebook contains general emergency response information for hazardous materials incidents. To use the guides (orange bordered pages), you must know either the DOT 4-digit identification number (yellow bordered pages), the proper shipping name (blue bordered pages), or the placard affixed to the car. The Emergency Response Guidebook also contains initial isolation and protective action distances (green bordered pages) for specific commodities.

This guidebook will assist responders in making initial decisions enroute or upon arriving at the scene of a hazardous materials incident. It should not be considered as a substitute for emergency response training, knowledge or sound judgment. The ERG does not address all possible circumstances that may be associated with a hazardous materials incident. It is primarily designed for INITIAL RESPONSE at a hazardous materials incident occurring on a highway or railroad.

5.5 AskRail® Mobile Application

The [AskRail mobile application](#) is a collaborative effort among the emergency response community, all Class I railroads and Railinc. The app provides more than 25,000 first responders — from all 50 states and eight Canadian provinces — with immediate access to accurate, timely data about the type of hazardous materials a railcar is carrying so they can make an informed decision about how to respond to a rail emergency.

AskRail serves emergency responders who arrive first to the scene of a rail emergency and who need to know the identity and location of railcars carrying hazardous materials. Through an easy-to-use mobile interface, emergency responders can query the contents of a railcar with a simple railcar ID search to see if a car is carrying hazardous material and, if so, what that material is.

With AskRail, emergency responders have immediate, secure access to accurate, critical data, sourced from railroads, that can help them make informed decisions and determine the next steps in their incident response. By performing an AskRail query on a railcar, emergency responders can view data such as:

- Loaded or empty status
- UN/NA ID for identifying hazardous materials
- Proper shipping name (PSN) for a railcar's contents
- Hazard class for the railcar's contents
- Train consist
- Railroad name
- Emergency contact information for all seven Class I railroads and Amtrak

5.5 AskRail® Mobile Application (continued)

AskRail also includes a list of the 125 hazardous materials most commonly shipped by rail and integrates information from the Pipeline and Hazardous Materials Safety Administration’s Emergency Response Guidebook (ERG).

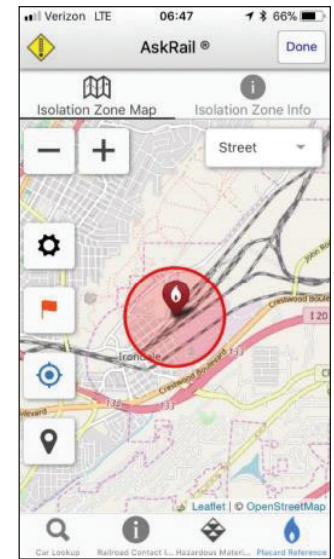
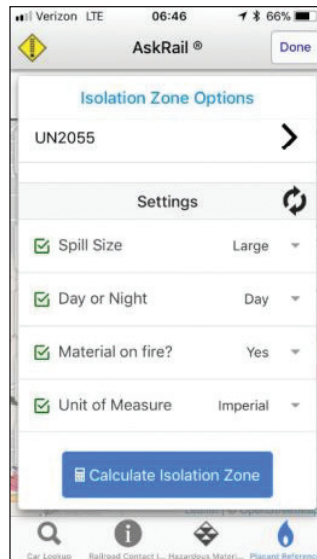
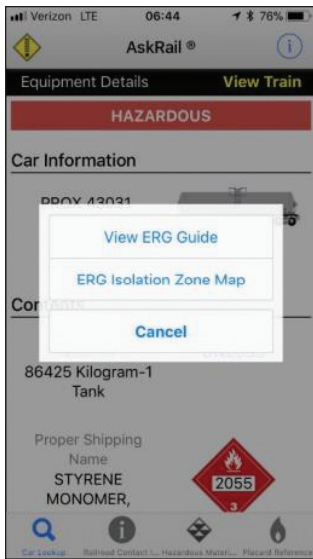
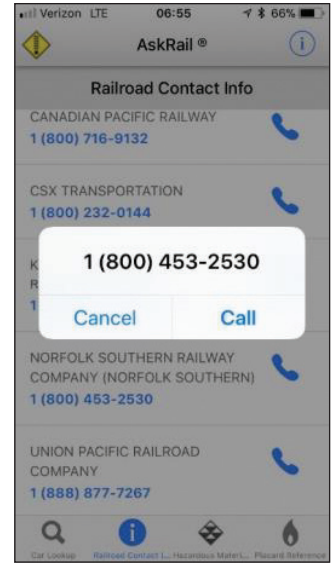
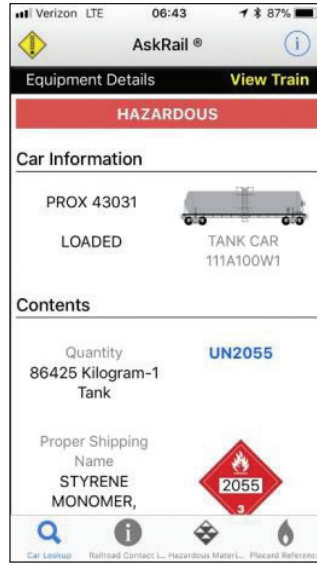
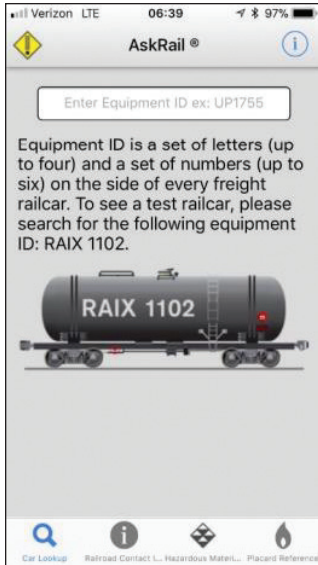

5.6 Association of American Railroads “Field Guide to Tank Cars”

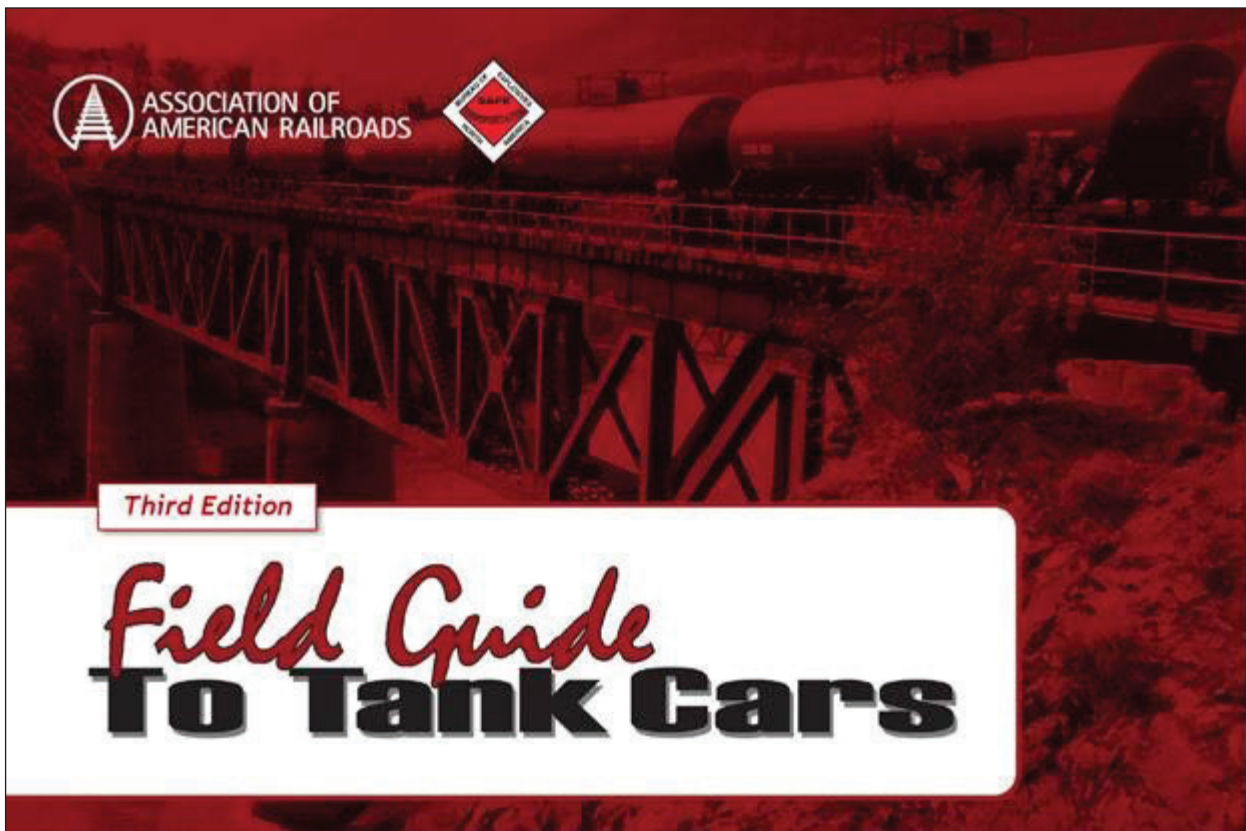

Field Guide to Tank Cars is intended to be used by emergency responders and others involved with rail-road tank cars. It provides information on the types, safety systems, stenciling, and markings of tank cars utilized to transport regulated (hazardous materials/dangerous goods) and nonregulated commodities.

For free download of the “AAR Field Guide to Tank Cars” go to:

<http://www.joinnsoar.com/pdf/2017-field-guide-for-tank-cars.pdf>

6.0 APPENDICES

6.1 Railroad Safety Checklist (Guidelines)

Walking near or across tracks:

Before attempting to walk or work on railroad property, tell the railroad you are there! Before entering a rail yard, responders should be aware that freight cars may be rolling freely and some locomotives are not manned during switching operations and are controlled remotely. Just because you can see the cab of a locomotive that is running does not mean that it is occupied and the operator can see you. The operator could be up to a half mile away from the locomotive. These remote control locomotives will have flashing yellow lights when being operated in “remote” mode. Exercise extreme caution and give yourself plenty of room when crossing tracks occupied by a remote control locomotive.

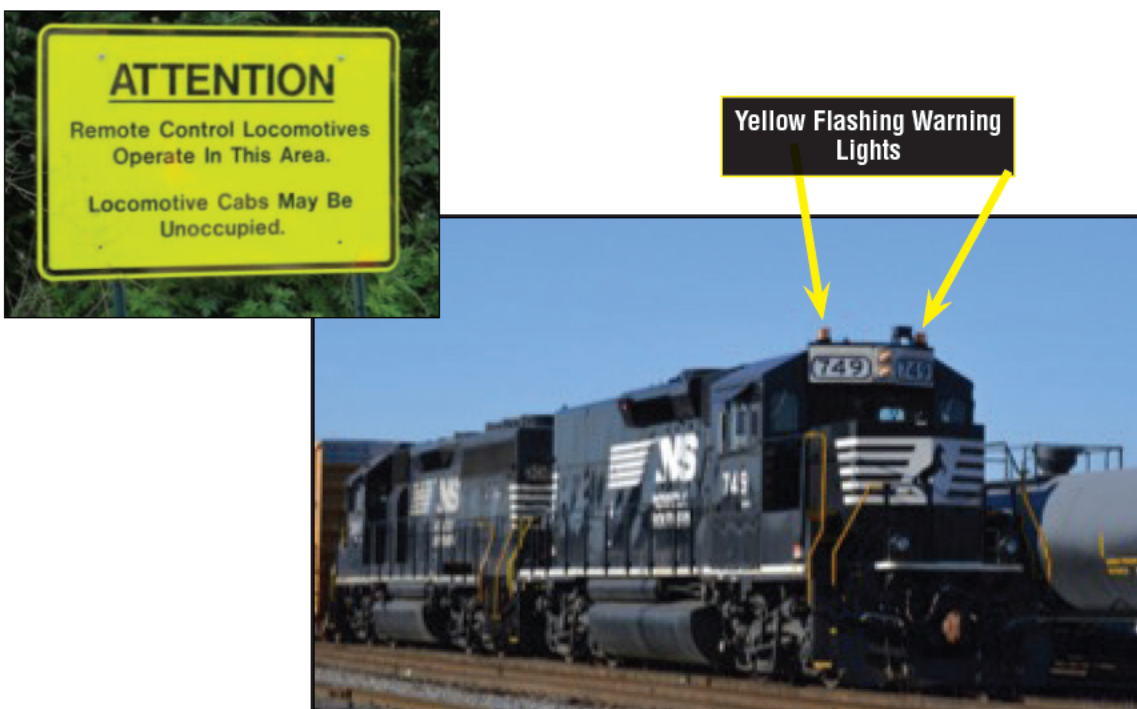

The walking surface (ballast) is uneven and difficult to walk on; be careful! If possible, cross only at a grade crossing which provides a better walking surface.

If you must cross tracks, stay at **least 10 feet** from the ends of equipment and look both ways; be sure no equipment is moving toward you. When near any track, expect a train to move in either direction at any time. Cross tracks at a 90 degree angle to maximize the field of vision. Make this move as quickly as possible so as to avoid being in the track any longer than necessary.

Don't cross tracks near switches or any other movable track structure, and never step on rails or other parts of the structure which may be slippery.

Ensure there is 50 feet of clearance between two pieces of standing equipment (while maintaining 25 feet of personal clearance from either side before attempting to cross between them).

Perform a job briefing with employees to review any necessary safeguards for the task to be performed.

6.1 Railroad Safety Checklist (Guidelines) *(continued)*

Fouling (obstructing) the track or dragging hoses across tracks:

Never climb on, over or under rail equipment unless the cars are chocked or have had the handbrakes applied and is being protected by railroad personnel.

Position yourself or equipment at least 25 feet away from the nearest rail. If you and your equipment are within 4 feet of the nearest rail, there is immediate danger of being struck either by equipment or material carried by rail cars. If you find that you must obstruct the track, then you must contact the railroad (via the Police Communications Center) and receive positive verification from the railroad that it is safe to do so.

Be careful when you must cross more than one track, parallel tracks may belong to two different companies or be under control of two different employees of the same company.

Stopping a train:

Because of the weight of trains, request a train to stop by contacting the employee in charge of the movement by telephone well in advance if possible (Chief Dispatcher, Yardmaster).

In an emergency, give a STOP signal to the train crew. Move your hand, flag, flashlight, or flare (anything **RED**) back and forth horizontally, at right angles to the track until acknowledged by a short blast of the locomotive horn or other response from the train crew. **A train may require more than a mile to stop, so make sure you plan for adequate stopping distance.** In the event of an emergency, place warning personnel 2 miles in both directions to signal train and protect personnel that may be working in the right of way.

Driving across tracks:

Cross only at grade crossings, heed all crossing-warning devices and remember: only the vehicle driver can prevent a crossing collision.

Attendance and Securement:

The Federal Railroad Administration (FRA) has issued special instructions stating:

“Anytime emergency responders have been on, under, or between rail equipment, the equipment must not be left unattended until an inspection for proper securement is performed by a qualified railroad employee.”

6.2 Railroad Equipment

Today freight railroads rely primarily on the diesel electric locomotives to move freight trains throughout North America. The locomotive's sheer size, its horsepower, and the electrical voltages it uses deserve a great deal of respect and some very careful action from emergency responders. It is no ordinary vehicle, and response to an incident involving a locomotive is much more complicated than that of other vehicle emergencies. The modern locomotive weighs 230 tons; is approximately 73 feet long, 15 feet high, and 10 feet wide; and produces up to 6,000 horsepower. It is a rolling electrical substation with a 74-volt starter system and may have 600 volts direct current (DC) or 30,000 volts alternating current (AC) or both when running.

The diesel fuel carried by these locomotives can range **between 1,000 and 7,000 gallons** as well as other fluids including a weak borate solution which dyes the water pink and is environmentally benign (200 gallons) for the cooling system, lubricating oil (up to 400 gallons) and sulfuric acid for the battery banks.

The electrical power that is generated is directed to the traction motors which applies torque to the axles through gear boxes that make up the drive assembly. This drive assembly, including the traction motors, can have the fields reversed to be used as part of the braking system when the locomotive is moving downgrade or slowing the train to a stop. The excess energy generated, when these motors are reversed, is known as dynamic braking. The dynamic braking grids that are located on the upper part of the locomotive, can become extremely hot during braking operations and may glow red. They may even be hot enough to melt and cause a fire.

6.2 Railroad Equipment (continued)

- Locomotives:**
- ❖ Diesel Fuel Tanks — up to 7,000 gallons
 - ❖ Electrical — 600 volts DC, 220 Volts AC
 - ❖ Lube Oil — up to 410 gallons
 - ❖ Coolant — up to 380 gallons
 - ❖ Battery Acid — up to 50 gallons
 - ❖ Compressed Air

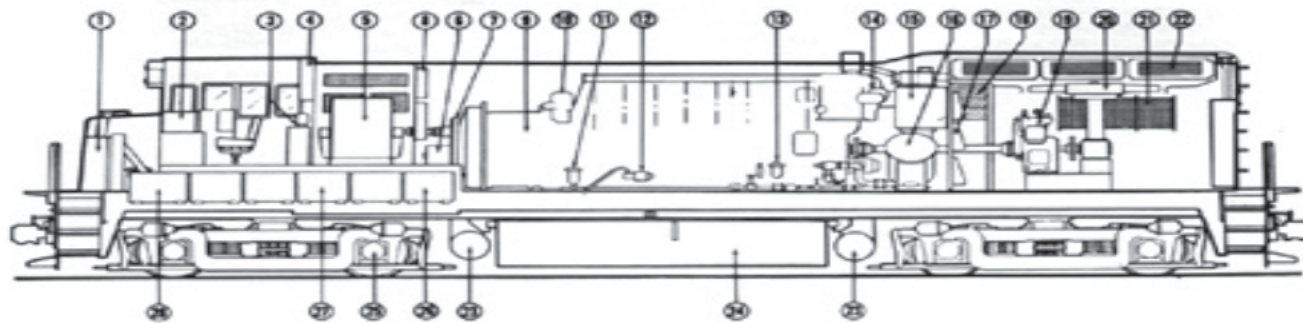
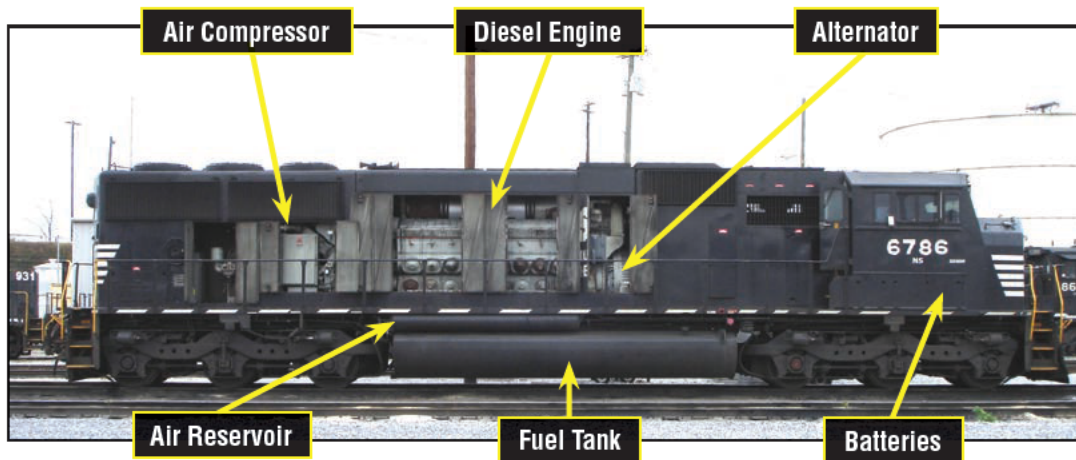

Fig. 22-B U MODEL LOCOMOTIVE

- | | | | |
|------------------------------------|-----------------------------|---|--|
| 1. Sand box | 9. Traction alternator | 18. Engine primary air cleaners | 25. Axle generator (one per axle) |
| 2. Operating air brake controls | 10. Engine control governor | 19. Air compressor | 26. Batteries (right side) |
| 3. Water cooler | 11. Fuel strainer | 20. Radiator fan | 27. Air-brake compartment (right side) |
| 4. Engine control panel | 12. Fuel booster pump | 21. Dynamic-brake grids (when equipped) | 28. Control compartment (left side) |
| 5. Equipment blower | 13. Lube-oil fill | 22. Radiator | |
| 6. Auxiliary generator (left side) | 14. Turbocharger | 23. Air reservoir | |
| 7. Traction-alternator gear case | 15. Water-storage tank | 24. Fuel tank | |
| 8. Power rectifier panels | 16. Lube-oil filter | | |
| | 17. Oil-bath air filters | | |

6.2 Railroad Equipment (continued)

Emergency Fuel Shutoff Locations



In an emergency, such as a fire, involving a locomotive, there are three locations that the emergency fuel cutoff may be found. The emergency fuel cutoffs are located on either side of the locomotive on the side frame rail just above the fuel tank and will be in the cab on the back wall. Each location will be clearly marked with a red button and label stating, "EMERGENCY FUEL CUTOFF". By pressing and holding any of these buttons, it will shut off the fuel supply to the diesel engine and shutting it down within seconds.

It is also recommended that the electrical systems be isolated and make the systems as energy free as possible. This can be accomplished by entering the cab, based on whether it is safe to do so, then opening the door marked "Battery Switch" and disengage the knife switch located behind the door. Please be aware that AC locomotives will have large capacitor banks that will still be energized, even if the battery isolation switch is open.



If a fire situation still exists, utilize a dry chemical extinguisher. **Do not use water on locomotive fires as there is high voltage.** If the fire is a crankcase explosion or turbo fire, isolate, evacuate, protect exposures, withdraw and allow the fire and fuels to consume themselves.

6.2 Railroad Equipment *(continued)*

Freight Cars

The various types of freight cars include:

- ❖ Tank Car
- ❖ Box Cars
- ❖ Mechanical Refrigerator Cars
- ❖ Covered Hopper Car
- ❖ Open Top Hopper Car
- ❖ Gondola
- ❖ Flat Car
- ❖ Automobile Carrier
- ❖ Intermodal Double-Stack Well Car



Pressure Tank Cars

Currently there are approximately 87,280 or 20% of the tank car fleet

Pressure Tank Car

- ❖ Protective housing
- ❖ No visible valves
- ❖ No bottom outlet
- ❖ Usually has a jacket, headshield, and insulation
- ❖ Double Shelf Couplers
- ❖ Transports Compressed Liquefied gases and TIH Products

General Service Tank Car

- ❖ Valves may be visible on top
- ❖ May have bottom outlet
- ❖ May have a jacket and insulation
- ❖ Shelf Couplers
- ❖ Transports liquid or semi-solid materials
- ❖ Transports both HazMat and Non-HazMat



General Service Tank Cars

Currently there are approximately 345,925 or 80% tank car fleet

6.2 Railroad Equipment (continued)



Cryogenic Tank Cars

Currently there are approximately 750 — less than .3% tank car fleet

Cryogenic Tank Car

- ❖ Valve Box on side of tank or at end
- ❖ May have valves/vents extended from box to top of car
- ❖ Products with temps less than -130°

Box Cars

- ❖ Can transport many materials in small packages
- ❖ May be insulated

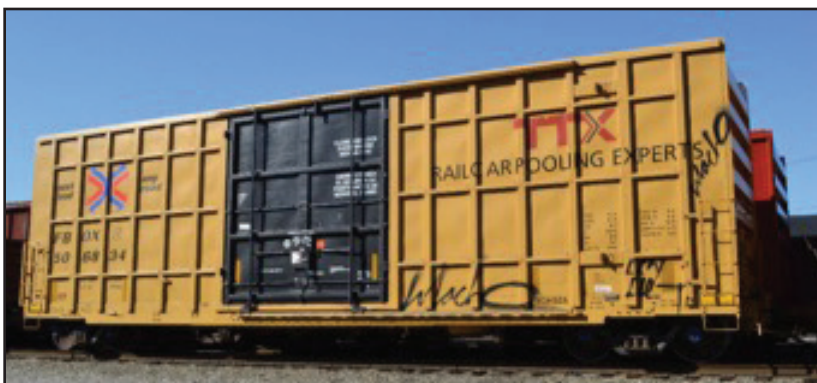

Mechanical Refrigerator Cars

- ❖ Refrigeration unit
- ❖ Fuel tank
- ❖ Battery with acid
- ❖ Ignition source

6.2 Railroad Equipment *(continued)*



Covered Hopper

Dry commodities like:

- ❖ Flour
- ❖ Grain
- ❖ Fertilizer (oxidizer)
- ❖ Cement
- ❖ Plastic Pellets

Open Top Hopper

Dry commodities:

- ❖ Stone
- ❖ Coal

Seldom carries hazardous materials.



Gondola

- ❖ Scrap metal
- ❖ Pipe
- ❖ Contaminated soil/waste

Hazardous material loads usually have a cover.

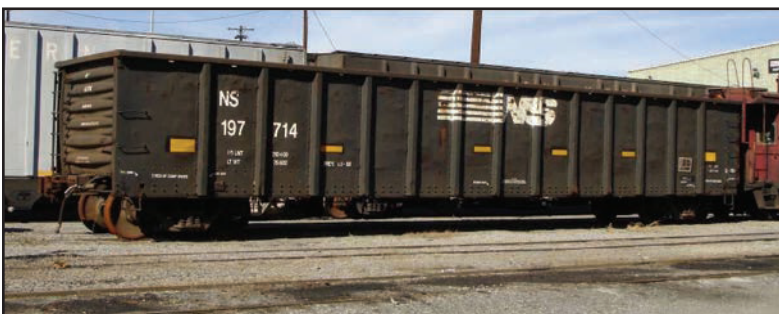

6.2 Railroad Equipment (continued)



Flat car

- ❖ Lumber
- ❖ Pipe
- ❖ Machinery

The car may have bulkheads or be equipped to carry autos, containers or trailers.

Auto carrier

May have up to 18 Automobiles

Danger from:

- ❖ Fuel
- ❖ Battery acid
- ❖ Air Bag inflators
- ❖ Refrigerants



Trailer on Flat Car or TOFC

6.2a Railroad Intermodal Equipment

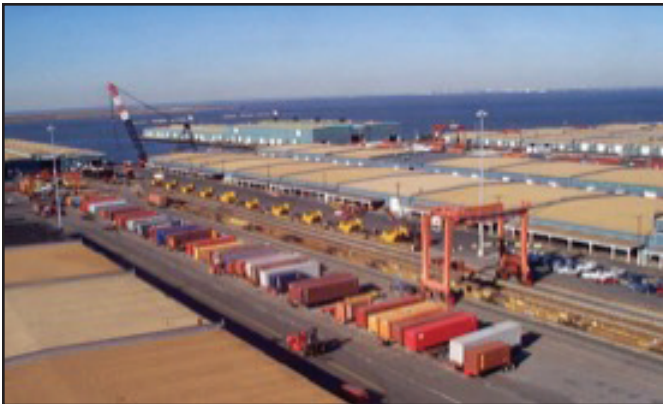

Intermodal Loading

Five platform
Double-Stack Car



Intermodal Tanks transport a wide range of commodities. The most common types have a capacity of 6,000 gallons.

Side View



Rear View



6.3 Tank Cars Valves & Fittings



MANWAY



Vacuum Relief Valve

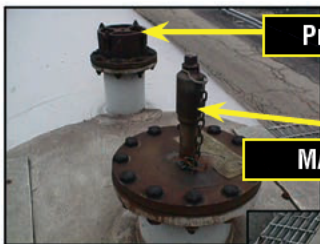

Pressure Relief Device (PRD)

MAGNETIC GAUGING DEVICE

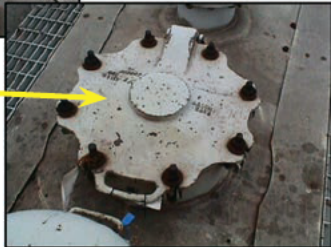

MANWAY

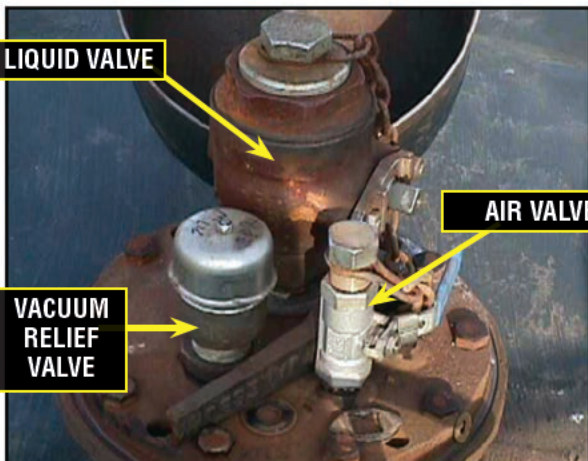
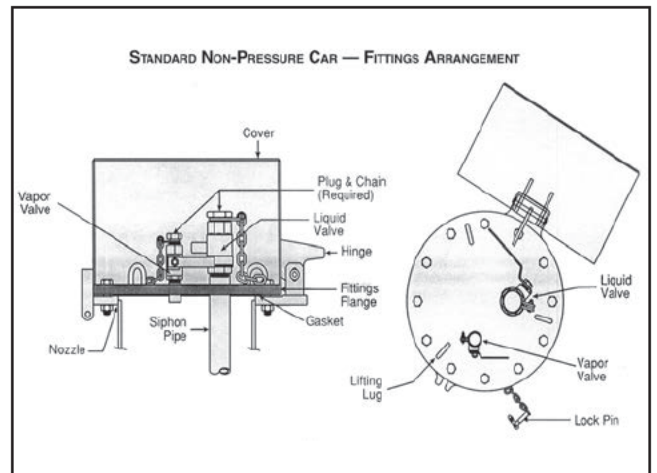

LIQUID VALVE

AIR VALVE

VACUUM RELIEF VALVE

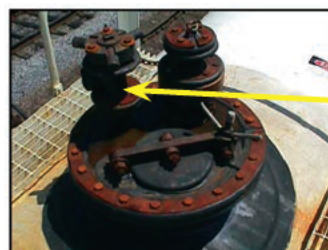

Acid Fittings

Safety Vent/Air Line



Liquid Line

Fill Hole

6.3 Tank Cars Valves & Fittings (continued)

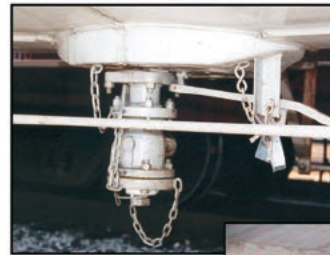
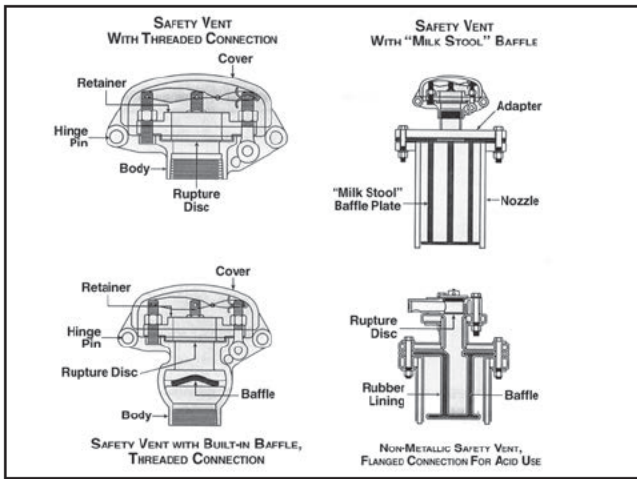

Internal Bottom Outlet Valves



Auxiliary Valve

DOT-117 Protective Housing with Valves



Kelso Klincher One Bolt Manway

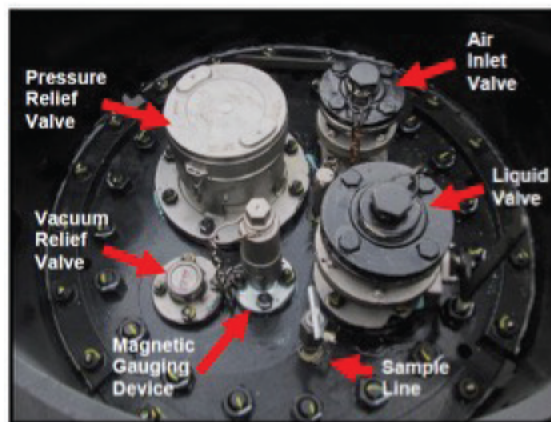

6.3 Tank Cars Valves & Fittings (continued)

Pressure Tank Cars



6.3 Tank Cars Valves & Fittings (continued)

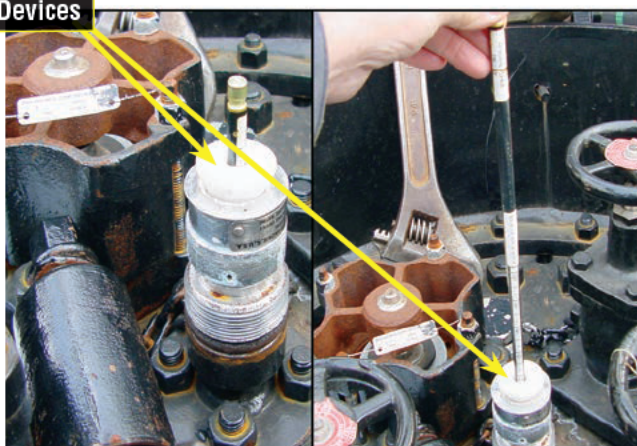
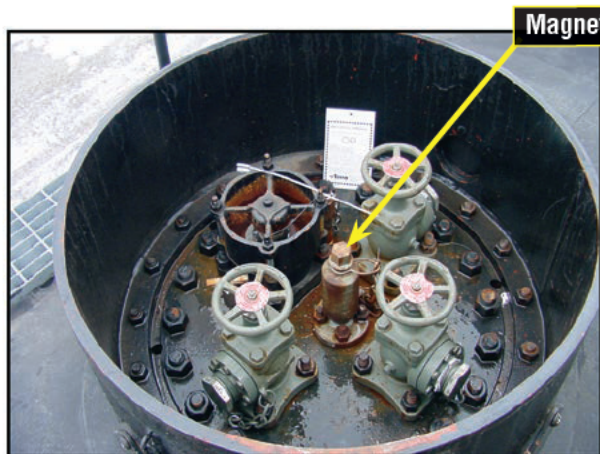
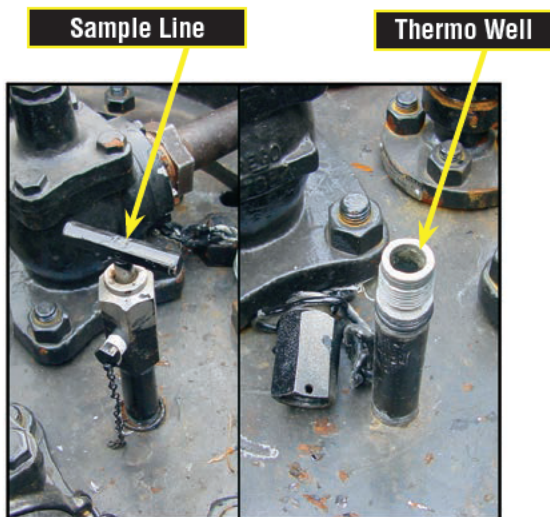

6.3 Tank Cars Valves & Fittings (continued)

Chlorine Fittings



Chlorine Angle Valve



Chlorine Safety Relief Device



COMBINATION SAFETY RELIEF DEVICE

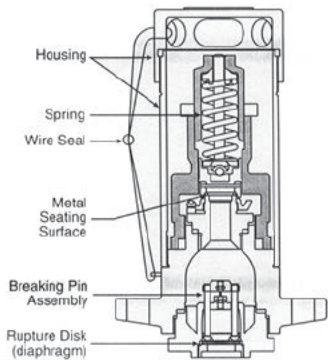

New valve arrangement for Chlorine and other service

6.3 Tank Cars Valves & Fittings (continued)

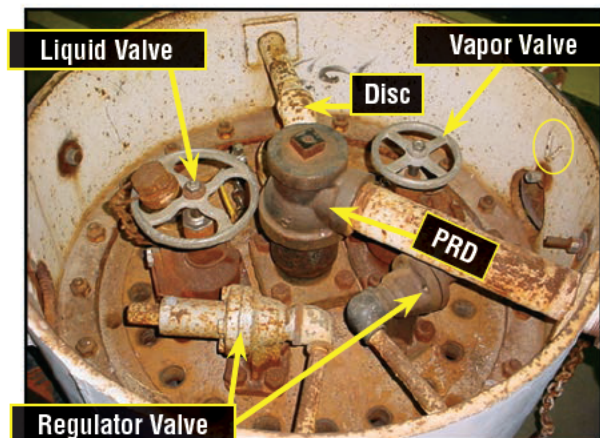
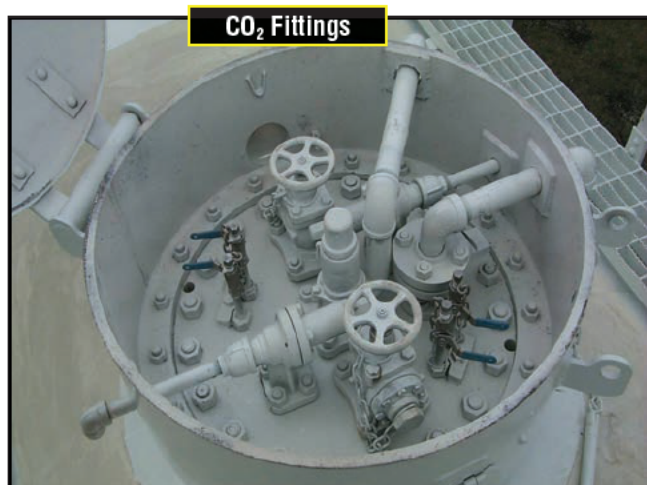

6.4 Freight Railroad Security

America's railroads have a long history of emphasizing security and law enforcement issues. The tragic events of September 11, 2001 have brought a significant amount of attention to the issue of the security of hazardous materials and military shipments in transportation. At Norfolk Southern and throughout the rail industry in the United States and Canada, much has been done to identify potential targets and develop appropriate countermeasures to minimize the potential opportunity of hazardous materials being transported by rail becoming viable terrorists targets.

National Security Effort

The nation's railroads, through an effort initiated by the Board of Directors of the Association of American Railroads (AAR), are in close regular contact with the U.S. Department of Homeland Security (DHS), Transportation Security Administration (TSA), Federal Bureau of Investigation (FBI), U.S. Department of Defense (DoD), United States Coast Guard (USCG) and the security and intelligence office of the U.S. Department of Transportation (DOT). Additionally, the AAR has a 24/7 Operations Center, the Railway Alert Network (RAN) to coordinate all freight railroad security actions with federal intelligence agency actions and plans.

Commitment and Vigilance

Norfolk Southern remains deeply committed to the safe transportation of hazardous materials by rail. We also recognize that now, more than ever, this also means maintaining high levels of security.

As we move forward and deal with these potentially serious threats within our country, we ask your assistance in being vigilant and reporting any unusual persons or activities on or near railroad property. Any unusual activities involving Norfolk Southern property should be reported to the Norfolk Southern Police Communications Center (PCC) at 1-800-453-2530.

PLEASE NOTE: The back cover of this book also contains the Norfolk Southern Police Communications Center phone number and can be copied and used as a notice to be posted at each 911, Communications, Dispatch, Emergency Medical Services (EMS) and Police Centers in areas served by Norfolk Southern Railway.

6.5 NS Media Contacts

Norfolk Southern procedures provide that communications with the media should be addressed through the local Incident Command System (ICS) by a Public Information Officer (PIO).

If a member of the media requests information from Norfolk Southern or seeks to talk with a NS public information representative, such requests/queries will be coordinated through Norfolk Southern's corporate communications main office: unless their representative is present at an incident site.

For Media Inquiries Concerning Norfolk Southern please contact:

**Norfolk Southern Corporate Communications
1-757-629-2717**

**After Hours
1-800-453-2530**

6.6 Online Sources of Information

American Chemistry Council — www.americanchemistry.com
American Short Line & Regional Railroad Association — www.aslrra.org
AMTRAK — www.amtrak.com
AskRail® — www.askrail.us/
Association of American Railroads — www.aar.org
Center for Toxicology and Environmental Health — www.cteh.com
CANUTEC (Canadian Transport Emergency Centre) — www.tc.gc.ca/canutec
CHEMTREC (Chemical Transportation Emergency Center) — www.chemtrec.com
Chlorine Institute — https://www.chlorineinstitute.org
ERG 2016 Online — http://www.phmsa.dot.gov/staticfiles/PHMSA/DownloadableFiles/Files/Hazmat/ERG2016.pdf
ERG 2016 Mobile — http://www.phmsa.dot.gov/hazmat/erg-mobile-app
Federal Emergency Management Agency — www.fema.gov
Federal Railroad Administration — www.fra.dot.gov
LEPC/SERC Net — www.rtk.net/LEPC
National Oceanic & Atmospheric Administration — www.noaa.gov
National Safety Council — www.nsc.org
National Transportation Safety Board — www.nts.gov
Norfolk Southern Corporation — www.nscorp.com
Operation Awareness & Response (OAR) — www.joinnsoar.com
Right-to-Know Network (searchable government databases) — www.rtk.net
TRANSCAER® — http://transcaer.teknicks.com
Transport Canada — www.tc.gc.ca/rail/menu.htm
Transportation Technology Center, Inc., Security and Emergency Response Training Center — www.aar.com
U.S. Department of Transportation — www.dot.gov
U.S. Environmental Protection Agency — www.epa.gov
U.S. Fire Administration (National Fire Academy) — www.usfa.fema.gov
U.S. National Response Team (Oil & HazMat Response) — www.nrt.org
U.S. Coast Guard — www.uscg.mil

6.7 Glossary of Chemical Terms

ACID

Any chemical which undergoes dissociation in water with the formation of hydrogen ions. Acids have a corrosive effect on metals and may cause severe tissue burns. Acids turn litmus paper red and have a pH value of 0 to 6.

ALKALI

Any chemical substance that in water solution is bitter and is irritating or caustic to skin and mucous membranes, turns litmus paper blue and has a pH value greater than 7.0. Alkalis are also referred to as bases. They may have a corrosive effect on metals and cause severe tissue burns.

APPEARANCE

A description of a substance at normal room temperature and normal atmospheric conditions. Appearance includes the color, size, and appearance.

ASKRAIL®

AskRail is a free mobile application that provides immediate access to accurate, near real-time information about railcars carrying hazardous materials on a train. It serves emergency responders who arrive first to the scene of a rail incident and helps them make informed decisions about how to respond to a rail incident

AUTO-IGNITION TEMPERATURE

The temperature at which a closed, or nearly closed container must be heated in order that a flammable liquid, when introduced into the container, will ignite spontaneously or burn.

BONDING

The interconnecting of two objects by means of a clamp and bare wire. Its purpose is to equalize the electrical potential between the objects to prevent a static discharge when transferring a flammable liquid or gas from one container to another. The conductive path is provided by the clamps which make contact with the charged object and a low resistance flexible cable which allows the charge to equalize.

COMBUSTIBLE LIQUID

As defined by DOT as any liquid having a flash point at or above 141°F (60.5°C), but below 200°F (93°C), except any mixture having components with flash points of 200°F (93°C) or higher, the total volume of which makes up ninety-nine percent (99%) or more of the total volume of the mixture.

CORROSIVE

As defined by DOT, a corrosive material is a liquid or solid that causes visible destruction or irreversible alterations in human skin tissue at the site of contact. In case of leakage from its packaging — a liquid that has a severe corrosive rate on steel. Two common examples are sodium hydroxide and sulfuric acid.

EXPLOSIVE

A chemical that causes a sudden, almost instantaneous release of pressure, gas, and heat when subjected to sudden shock, pressure or high temperature.

6.7 Glossary of Chemical Terms (continued)

FLAMMABLE LIQUID

As defined by DOT is any liquid having a flash point below 141°F (60.5°C), except any mixture having components with flash points of 100°F (37.8°C) or higher, the total of which make up ninety-nine percent (99%) or more of the total volume of the mixture.

FLAMMABLE SOLID

A solid, other than a blasting agent or explosive that is liable to cause fire through friction, absorption of moisture, spontaneous chemical change or retained heat from manufacturing processing, or which can be ignited readily and when ignited burns so vigorously and persistently as to create a serious hazard.

FLASH POINT

The temperature at which a liquid will give off enough flammable vapor to ignite if an ignition source is present.

HAZARDOUS MATERIALS

Hazardous materials are defined as *“a substance or material which the Secretary of Transportation has determined to be capable of posing an unreasonable risk to health, safety, and property when transported in commerce.”*

The term “hazardous material” includes hazardous substances, hazardous wastes, elevated temperature materials (HOT or MOLTEN), and marine pollutants.

IGNITABLE

Capable of being set afire.

IMPERVIOUS

A material that does not allow another substance to pass through or penetrate it.

INCOMPATIBLE

Materials which could cause a dangerous reaction from direct contact with one another.

INSULATION

A material used to maintain the temperature of the lading contain in a tank car. It may be made from fiberglass, rock wool, foam, cork, etc.

LC₅₀

(Lethal Concentration - 50) is the concentration of a material in air which causes the death of 50% (one half) of a group of test animals. The material is inhaled over a set period of time, usually 1 or 4 hours and is usually measured in parts per million.

LD₅₀

(Lethal Dose - 50) means a dose of a substance when ingested, injected, or applied to skin produces death in 50% (one half) of a population of experimental animals. It is usually expressed as milligrams per kilogram (mg/kg) of body weight.

6.7 Glossary of Chemical Terms (continued)

LOWER EXPLOSIVE LIMIT (LEL)

Lowest concentration (percentage) of a gas or vapor in air capable of producing a flash of fire in presence of an ignition source (arc, flame, heat). Concentrations lower than LEL are 'too lean' to burn. Also called lower flammable limit (LFL).

ORGANIC PEROXIDE

Any organic (carbon-containing) compound having two oxygen atoms joined together (-O-O-). Organic peroxides can be severe fire and explosion hazards.

OXIDIZER

A compound that spontaneously evolves oxygen either at room temperature or under slight heating. DOT defines it as a material that may, generally by yielding oxygen, cause or enhance the combustion of other materials. Chlorate, permanganate, and nitrate compounds are examples of oxidizers.

POISON (TOXIC)

A material that can cause short and/or long term systemic health problems and possibly death, through inhalation, ingestion, or absorption.

POISON INHALATION HAZARD (PIH) OR TOXIC INHALATION HAZARD (TIH)

A DOT designation for gases and certain high vapor pressure liquids which, through the inhalation of small amounts, can cause severe health effects and even death.

POLYMERIZATION

Polymerization is a chemical reaction in which one or more small molecules combine to form larger molecules. Some materials are shipped with an inhibitor (or stabilizing agent) to delay polymerization and are limited in the amount of time they can be in transportation. A hazardous polymerization occurs when a reaction occurs (due to loss of inhibitor, contamination, or exposure to heat) at a rate which releases large amounts of energy in a confined space such as a tank car.

PYROPHORIC

Any liquid or solid that will spontaneously ignite in air at or below a temperature of 130°F (54.5°C).

REACTIVITY

The tendency of a substance to undergo chemical reaction with the release of energy. Undesirable effects — such as pressure buildup, heat, formation of noxious, toxic, corrosive, or flammable by-products may occur because of the reactivity of a substance to heating, burning, direct contact with other materials or conditions in use or storage.

REDUCING AGENT

A reducing agent is a chemical or substance which combines with oxygen or loses electrons to the reaction. In a reduction reaction (which always occurs simultaneously with an oxidation reaction) the reducing agent is the chemical or substance which combines with oxygen or loses electrons in the reaction.

6.7 Glossary of Chemical Terms *(continued)*

SOLUBILITY IN WATER

A term expressing the percentage of a material (by weight) that will dissolve in water at ambient temperature. Solubility information can be useful in determining spill cleanup methods and fire-extinguishing agents and methods for a material. Terms used to express solubility are:

Negligible.....	< 0.1%
Slight.....	0.1 to 1.0%
Moderate	1 to 10%
Appreciable	More than 10%
Complete.....	Soluble in all proportions

SPECIFIC GRAVITY

The weight of a material compared to the weight of an equal volume of water; an expression of the density of the material. Example: if a volume of a material weighs 8 pounds, and an equal volume of water weighs 10 pounds, the material is said to have a specific gravity of 0.8. Materials with a specific gravity of less than 1.0 will float on water. Materials with a specific gravity greater than 1.0 will sink to the bottom. Most (but not all) flammable liquids have a specific gravity of less than 1.0 and (if not soluble) will float on water.

SPONTANEOUSLY COMBUSTIBLE

A material that ignites as a result of retained heat from processing, or which will oxidize to generate heat and ignite, or which absorbs moisture to generate heat and ignite.

TOXIC (POISON)

A solid, liquid, paste, or semi-solid substance which is known (or presumed on the basis of animal testing) to be as toxic to humans as to afford a hazard to health during transportation. Exposure can cause short and/or long term systemic health problems and possibly death, through inhalation, ingestion, or absorption.

UPPER EXPLOSIVE LIMIT (UEL)

Highest concentration (percentage) of a gas or vapor in air capable of producing a flash of fire in presence of an ignition source (arc, flame, heat). Concentrations higher than UEL are 'too rich' to burn. Also called upper flammable limit (UFL).

VAPOR DENSITY

The weight of a vapor or gas compared to the weight of an equal volume of air; an expression of the density of the vapor or gas. Materials lighter than air have vapor densities less than 1.0. Materials heavier than air have vapor densities greater than 1.0. The vapors from materials with vapor densities greater than 1.0 are likely to migrate to low lying areas — along or under floors, in sumps, sewers and manholes, in trenches and ditches — where they may create fire or health issues or displace oxygen.

WATER REACTIVE

A chemical that reacts with water to release a gas that is either flammable or presents a health hazard.

6.8 Acronyms

ACC	American Chemistry Council
AAR	Association of American Railroads
BNSF	Burlington Northern Santa Fe Railroad
CFR	Code of Federal Regulations
CHEMTREC	Chemical Transportation Emergency Center
CIA	Central Intelligence Agency
CN	Canadian National Railroad
CP	Canadian Pacific Railroad
CR	Conrail
CSXT	CSX Transportation, Inc.
DHS	Department of Homeland Security
DOD	United States Department of Defense
DOT	United States Department of Transportation
EBS	Emergency Broadcast System
EMS	Emergency Medical Services
EPA	United States Environmental Protection Agency
ERG	Emergency Response Guidebook
FBI	Federal Bureau of Investigation
FEC	Florida East Coast Railway
FEMA	Federal Emergency Management Agency
FRA	Federal Railroad Administration
GST	General Superintendent Transportation
HAZMAT	Hazardous Material
HAZWOPER	Hazardous Waste Operations and Emergency Response
HMERP	Hazardous Materials Emergency Response Plan
HMRC	Hazardous Materials Response Code
ICS	Incident Command System
KCS	Kansas City Southern Railroad
LEPC	Local Emergency Planning Committee

6.8 Acronyms *(continued)*

NA	North America
NENA	National Emergency Number Association
NIMS	National Incident Management System
NRC	National Response Center
NS	Norfolk Southern Railway Company
NTSB	National Transportation Safety Board
OAR	Operation Awareness & Response
OSHA	Occupational Safety and Health Administration
PCC	Norfolk Southern's Police Communications Center
PIH	Poison Inhalation Hazard (synonymous with TIH)
PIO	Public Information Officer
RQ	Reportable Quantity
SCBA	Self-Contained Breathing Apparatus
SDS	Safety Data Sheets
STB	Surface Transportation Board
STCC	Standard Transportation Commodity Code
STRACNET	Strategic Rail Corridor Network
TIH	Toxic Inhalation Hazard (synonymous with PIH)
TRANSCAER®	Transportation Community Awareness and Emergency Response
TSA	Transportation Security Administration
UN	United Nations
UP	Union Pacific Railroad
USCG	United States Coast Guard

POLICE AND EMERGENCY RESPONDERS HAZARDOUS MATERIALS POCKET RESPONSE GUIDE























TO USE THIS GUIDE — review this side for general recommendations when you are first on scene at a HazMat incident.

REVIEW SIDE 2 — for a brief description of the types of hazards and example materials associated with each of the U.S. DOT placards.

1. Immediately notify dispatcher that you are involved in a possible hazardous materials accident. Provide the following minimum information about the incident:
 - THE EXACT LOCATION
 - TYPE OF VEHICLE INVOLVED
 - INITIAL PRESENCE OF HAZARDOUS MATERIALS (PLACARDS, PANELS, etc.)
 - PRESENCE OF FIRE, SPILLED LIQUIDS, OR VAPOR LEAKS
 - KNOWN INJURIES
 - DO NOT ATTEMPT TO RESCUE INJURED OR RETRIEVE DOCUMENTATION UNTIL SITUATION IS ASSESSED.
2. Note the type of placards and numbers present. If possible, look for rectangular orange panels and note number. These numbers are UN/NA numbers and will aid in the identification of the contents.
3. Carefully observe the incident before approaching. Be alert to signs of leakage such as sounds of escaping gas, evidence of liquid leak, odd smells, vapor clouds.
4. Approach accident scene from the upwind side. Do not park in the potential path of leaking materials. **DO NOT DRIVE INTO VAPOR CLOUDS. Remember, VEHICLES ARE AN IGNITION SOURCE.**
5. Initially isolate the accident scene for a radius of 250 feet to allow room for response personnel. If cargo involved in fire or fire probable evacuate to a radius of 500 feet to allow firefighters additional working clearance. Adjust distances as conditions warrant.
6. **DO NOT USE FLARES** in the vicinity of the incident, flammable vapors may be present.
7. Prohibit traffic from passing through the incident. Do not allow bystanders to congregate around the incident.
8. Note wind direction. Note if material is running into sewers, waterways, ditches. If possible, estimate the quantity of material leaking. Pass this information to your dispatcher or responding fire units.
9. When isolating accident scene, give priority to removing persons from oncoming smoke or vapor.
10. Do not step in pools of liquid or any unfamiliar material. Avoid contact with any chemical material.
11. Do not open trailers of hazardous cargo. Trailers may contain hazardous vapors or loose cargo which may cause death or injury.

NOTE: Liquid oxygen may mix with asphalt to create a highly shock sensitive explosive. Do not contact liquid oxygen contaminated asphalt under any circumstances, it may detonate even under foot. Completely isolate contaminated asphalt.

POLICE AND EMERGENCY RESPONDERS HAZARDOUS MATERIALS POCKET RESPONSE GUIDE

	<p>CLASS 1 (EXPLOSIVES) — Liable to detonation under appropriate circumstances such as fire or shock. Usually stable if not involved in fire or not moved. Do not handle unless trained and equipped. <i>Division 1.1</i> — Mass Explosion Hazard, <i>Division 1.2</i> — Explosion Hazard with Fragmentation, <i>Division 1.3</i> — Radiant Heat and/or Violent Burning Hazard, No Blast Hazard, <i>Division 1.4</i> — Small Hazard of Ignition or Initiation During Transport, <i>Division 1.5</i> — Mass Explosion Hazard But Very Insensitive, <i>Division 1.6</i> — Extremely Insensitive with No Mass Explosion Hazard.</p>	
	<p>DIVISION 2.1 (FLAMMABLE GAS) — Compressed gasses which are flammable. May also be toxic or corrosive. Vapors may travel considerable distance to a source of ignition and flash back to the source. Many of these gasses are heavier than air and will tend to spread close to ground level. <i>Examples:</i> Propane, Butane, and welding gasses such as Acetylene.</p>	
	<p>DIVISION 2.2 (NON-FLAMMABLE GAS) — Compressed gasses which are not flammable. May also be corrosive or toxic. These gasses may suffocate by oxygen displacement. While not flammable, some of these gasses may support and even accelerate a fire. High pressure containers can rocket or throw shrapnel if exposed to fire or ruptured. <i>Examples:</i> Anhydrous Ammonia, Compressed Air, Nitrogen, Argon, Carbon Dioxide.</p>	
	<p>DIVISION 2.3 (POISON GAS) — Extremely toxic compressed gas or high vapor pressure liquid. Even low level exposure to vapors or fumes may result in serious injury or death. May be flammable and/or corrosive as well. <i>Examples:</i> Chlorine, Hydrocyanic Acid, Phosgene, Ethylene Oxide.</p>	
	<p>CLASS 3 (FLAMMABLE and COMBUSTIBLE LIQUIDS) — One of the most common hazardous materials classifications including gasoline, some alcohols, paints, thinners, etc. May be toxic and corrosive as well. <i>Flammable liquids</i> evolve vapors which will generally ignite readily when exposed to an ignition source. Some of these vapors may be harmful. <i>Combustible liquids</i> will burn but require some effort to ignite. They do not meet the criteria for any other hazard class and range from paint thinners to heating oils. They are not regulated in shipping containers of 110 gallons or less.</p>	
	<p>CLASS 4 (FLAMMABLE SOLIDS) — This Class includes materials which are <i>FLAMMABLE SOLIDS</i> (Division 4.1), <i>SPONTANEOUSLY COMBUSTIBLE MATERIAL</i> and <i>PYROPHORIC LIQUIDS</i> (Division 4.2), and <i>DANGEROUS WHEN WET</i> (Division 4.3). These materials are liable through friction, contact with air, water, or by self heating, to ignite and burn with great intensity or produce flammable gasses. Many are toxic if taken internally such as through contaminated food, contaminated cigarettes, or water. Usually highly reactive and if involved in a fire may burst their containers. <i>Examples:</i> Phosphorus Sodium Metal, Calcium Carbide.</p>	
	<p>CLASS 5 (OXIDIZERS and ORGANIC PEROXIDES) — Very reactive with wood, oils, fuels, paper, or any organic material, to generate heat, ignite or explode. Will promote and accelerate fires to the point of possible explosion. Will react with skin and clothing. Usually does not present a vapor hazard unless reacting or involved in a fire. On heating may decompose explosively. <i>Examples:</i> Hydrogen Peroxide, Potassium Permanganate, Ammonium Perchlorate, Dry Chlorine for swimming pools, some fertilizers.</p>	
	<p>CLASS 6 (POISONOUS MATERIAL) — Toxic liquids or solids. Not highly flammable, but may be mixed in oil carriers. Not severely corrosive. Primarily toxic by skin contact or ingestion. May be toxic by inhalation of vapors or dust if dust is airborne or material is on fire. May be extremely poisonous and if exposure occurs death may result very quickly. <i>Examples:</i> Arsenic, Sodium Cyanide, Strychnine, and many pesticides.</p>	
	<p>CLASS 7 (RADIOACTIVE) — Emits harmful radiation which cannot be detected without specialized instruments. High level materials are packed in such strong packages that leakage is a very low possibility. Medical materials are often shipped in small lead vessels. Low level wastes include debris contaminated with small amount of radioactive material. These include such items as clothing, paper, tools, etc. Do not contact these materials or handle broken packages.</p>	
	<p>CLASS 8 (CORROSIVE) — Acids or bases which may be in liquid or solid form. They will attack a variety of metals and will produce severe damage to skin on contact. May react with other materials such as water to evolve heat and gasses. In a violent reaction, acids or bases may produce a large volume of corrosive vapors which may spread a considerable distance. <i>Examples:</i> Hydrochloric Acid, Sulfuric Acid, and Caustic Soda.</p>	
	<p>CLASS 9 (Miscellaneous Hazardous Materials) — Materials which do not fit another hazard class such as those which have an anesthetic, noxious, or other similar property which could affect a flight crew; or hazardous substances or hazardous wastes which do not meet the definition of another hazard class or division. <i>Examples:</i> Acetaldehyde Ammonia, PCB's, Sodium Chromate.</p> <p>Indicates a Mixed load of Hazardous Materials on board.</p> <p>Limited Quantity — Labels are for use on the shipment of dangerous goods packaged in limited quantities.</p> <p>Regulations allow the use of a label with printed UN number on packages in place of displaying the proper shipping name.</p>	

NS Hazardous Materials Group – Territory Map

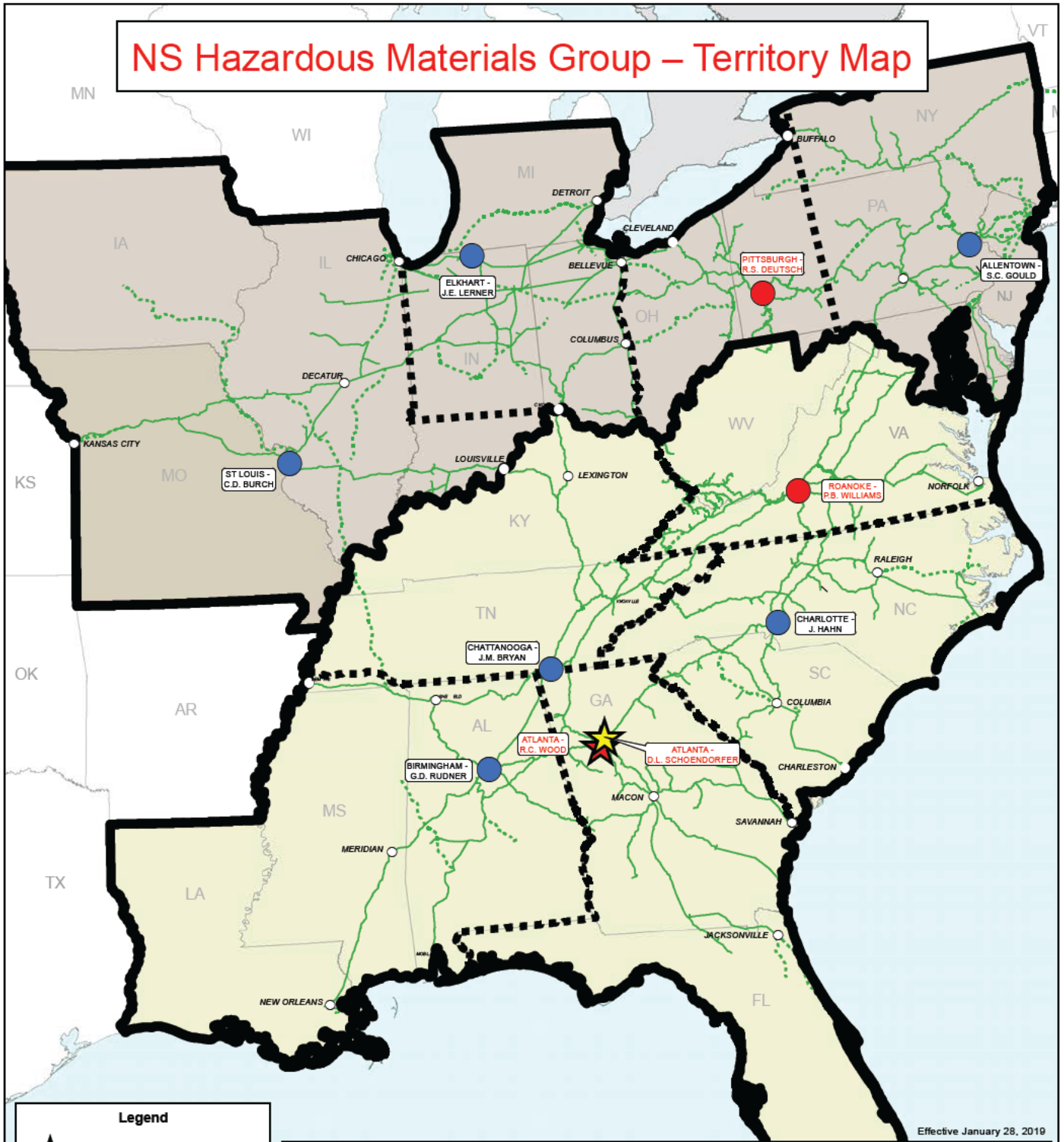

Effective January 28, 2019

Legend

-  System Manager Hazardous Materials
-  Asst. System Manager Hazardous Materials
-  Regional Manager Hazardous Materials
-  Hazardous Materials Compliance Officer
-  Northern Region
-  Southern Region

NS HAZARDOUS MATERIALS GROUP				
NAME	TITLE	LOCATION	OFFICE	CELL
D.L. Schoendorfer	System Manager Hazardous Materials	Atlanta, GA	404-582-3762	
R.C. Wood	Asst. System Manager Hazardous Materials	Atlanta, GA	404-529-2242	
NORTHERN REGION				
R.S. Deutsch	Regional Manager Hazardous Materials	Pittsburgh, PA	412-893-7142	
J.E. Lerner	Hazardous Materials Compliance Officer	Elkhart, IN	574-296-2215	
S.C. Gould	Hazardous Materials Compliance Officer	Allentown, PA	717-541-2203	
C.D. Burch	Hazardous Materials Compliance Officer	St Louis, MO	314-679-1714	
SOUTHERN REGION				
P.B. Williams	Regional Manager Hazardous Materials	Roanoke, VA	540-524-6942	
G.D. Rudner	Hazardous Materials Compliance Officer	Birmingham, AL	205-451-4787	
J.M. Bryan	Hazardous Materials Compliance Officer	Chattanooga, TN	423-697-1547	
J.W. Hahn	Hazardous Materials Compliance Officer	Charlotte, NC	704-378-3788	

**FOR INCIDENTS / EMERGENCIES
INVOLVING NORFOLK SOUTHERN
TRACK OR EQUIPMENT**

CALL THE NORFOLK SOUTHERN*

PCC POLICE
COMMUNICATIONS CENTER

1-800-453-2530

** Open 24 hours!*



NS NORFOLK
SOUTHERN

®