

# **Best Practices Guide**

**for**

## **Maintaining Exhaust System Turbocharger to Tailpipe V-band Couplings / Clamps**

Reference:

JASC 8100 Exhaust Turbine System (reciprocating)  
JASC 8120; Exhaust Turbocharger

**April 2018**

## TABLE OF CONTENTS

1.0 INTRODUCTION .....	1
1.1 Objective .....	1
1.2 Scope.....	1
1.2.1 Installations (typical) .....	1
1.2.2 Turbochargers (typical) .....	6
2.0 COUPLING & CLAMP DESIGN.....	8
3.0 INSTALLATION [Refer to Section 1.2.1 and Figures 1, 7, 9-14, 16 & 17].....	14
3.1 Methods.....	14
3.2 Tips & Hints.....	20
4.0 INSPECTIONS .....	21
4.1 Installed Inspection - Coupling/Clamp Installed .....	21
4.2 Uninstalled Inspection - Coupling/Clamp In-hand.....	24
5.0 UNSATISFACTORY CONDITIONS.....	26
6.0 REPETITIVE INSPECTION & LIFE-LIMITING .....	27
7.0 V-BAND COUPLING & CLAMP FAILURES.....	29
7.1 Spot-welded, Multi-segment, Coupling Failures Encountered.....	29
7.2 Single-piece, Clamp Failures Encountered.....	33

## LIST OF FIGURES

Figure		Page
1	Multi-segment, V-band Coupling	9
2	Multi-segment, V-band Couplings	9
3	Spot-welded, Multi-segment, V-band Couplings	10
4	Spot-welded, Multi-segment, V-band Couplings	11
5	Spot-welded, Multi-segment, V-band Couplings	11
6	Riveted, Multi-segment, V-band Coupling	12
7	Single-piece, V-band Clamp	13
8	Single-piece, V-band Clamp	14
9	Typical Turbocharger Exhaust Exit Flange to Tailpipe Interface	15
10	Typical Installation of Tailpipe and Coupling on Exhaust Exit Flange	17
11	Coupling & Clamp Installation Clearances	18
12	Multi-segment Coupling Safety Wired	19
13	Multi-segment Coupling Safety Wired	19
14	Multi-segment, V-band Coupling	23
15	Multi-segment, V-band Coupling	23
16	Single-piece, V-band Clamp	24
17	Typical Turbocharger to Tailpipe Interface Area	25
18	Spot-welded, 2-segment, Coupling with Quick Release Latch	29
19	Same Coupling Above Magnified	29
20	Spot-welded, 3-segment, Coupling	30
21	Spot-welded, Multi-segment, Coupling	30
22	Spot-welded, 3-segment, Coupling	31
23	Same Coupling Above Magnified	31
24	Spot-welded, 3-segment, Coupling	32
25	Same Coupling Above Magnified	32
26	Single-piece Clamp	33
27	Single-piece Clamp	33

## **1.0 INTRODUCTION**

### **1.1 Objective**

This Best Practices Guide presents a summary of one of the recommendations developed during the national V-band Coupling/Clamp Working Group effort. It was driven by the General Aviation Joint Steering Committee (GAJSC) System Component Failures – Power Plant (SCF-PP) working group initiative to investigate the continued failures of turbocharger exhaust to tailpipe V-band coupling/clamps. This guide presents the “best practices” necessary to ensure airplanes equipped with turbocharged reciprocating engines fitted with turbocharger to tailpipe V-band coupling/clamps, remain in their original type design configuration. It will also help to effectively manage the risk associated with the use of V-band coupling/clamps in this application.

### **1.2 Scope**

The national V-band Coupling/Clamp Working Group examined a wide range of products and configurations in developing this Best Practice Guide. The scope of the working group effort included:

- A history of V-band coupling/clamp failures dating from the 1970’s
- Approximately 18,000 applicable aircraft in the existing fleet
- At least eight turbocharged reciprocating engine-powered aircraft currently in production
- Single and multi-engine airplanes & single engine rotorcraft from:
  - Commander Aircraft
  - Enstrom Helicopter
  - Mooney Aircraft
  - Piper Aircraft
  - Textron Aviation, Inc. (formerly Cessna & Beechcraft)
- Turbocharged reciprocating engines from:
  - Continental Motors
  - Lycoming Engines
- Type certificated (TC) products
- Supplemental type certificated (STC) products
- Multiple Original Equipment Manufacturers (OEM) of V-band coupling/clamps
- Parts Manufacturing Approval (PMA) replacement V-band coupling/clamps

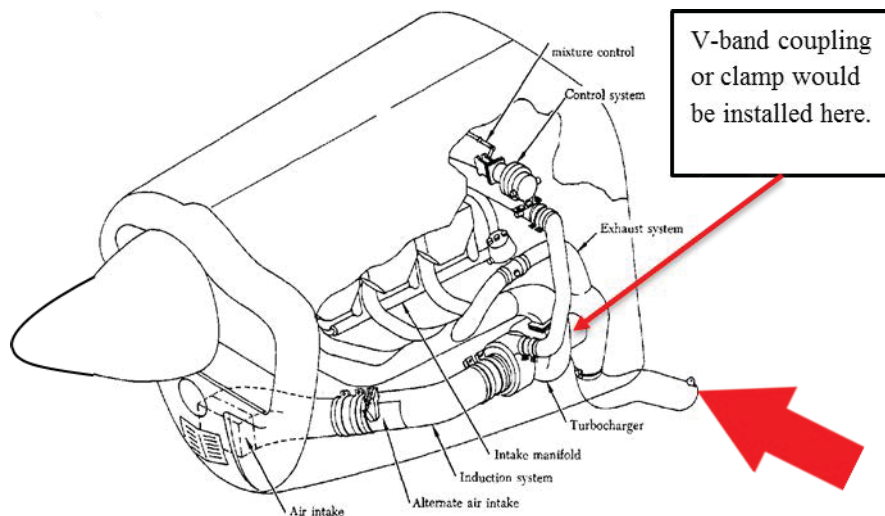
#### **1.2.1 Installations (typical)**

The specific focus area of this Best Practice Guide are those V-band couplings and clamps used at the turbocharger exhaust exit to exhaust tailpipe interface only. However, the installation and inspection recommendations herein may be applicable to any V-band coupling or clamp in any aircrafts exhaust system. The photographs and diagrams on the following pages present a very small sample of the various configurations that exist in the make/model of aircraft equipped with turbocharged reciprocating engines.

Below is a single engine airplane with engine cylinder exhaust ports located at the bottom of each cylinder. The upper cowl is open and a lower access panel is removed. As you can see the turbocharger in this application is not readily visible nor is the V-band coupling/clamp. The Design Approval Holder (DAH) also incorporated heat protection features in their type design to prevent exhaust heat from impinging on the surrounding area. The heat protection features typically include a set of sheet metal heat shields or fireproof foil type insulation in the form of a blanket or a combination thereof. The heat protection features that are a necessity also work well to obscure visibility of the turbocharger, and V-band coupling/clamps. The large red arrow denotes the tailpipe.



The diagram below depicts the turbocharger installation for the airplane above and the LH-side of the exhaust system. Notice none of the type design required heat protection features are shown installed. This is a typical retractable landing gear, single turbocharged engine airplane. The large red arrow denotes the tailpipe. The other arrow points to where the V-band coupling/clamp should be found. The V-band coupling/clamp in this application would not be readily visible during a pre-flight type inspection.



Another turbocharged single engine airplane, with engine cylinders with bottom exhaust ports is depicted below. The cowling has been removed. You can't see the turbocharger clearly with the lower cowling installed. The large red arrow denotes the tailpipe which is connected directly to the turbocharger exhaust exit flange just up and aft on the tailpipe. The tailpipe V-band coupling/clamp is not visible below. As you can see by the installation, the turbocharger in this application is not readily visible without a significant amount of maintenance activity, nor is the V-band coupling/clamp. In other words, this coupling /clamp installation would also not be readily accessible for pre-flight inspection.



In the two examples above, the interface to the turbocharger housing is such that the coupling partly resides within the turbochargers envelope. Seeing the turbocharger side of the coupling during inspection is not readily accomplished, even with a mirror and bright light. Turbochargers installed low on the engine (4 or 8 o'clock) like the two above make pre-flight viewing almost impossible. Inspection and maintenance of the turbocharger and tailpipe also have additional challenges, especially on retractable landing gear airplanes with non-removable lower cowlings and fixed structures.

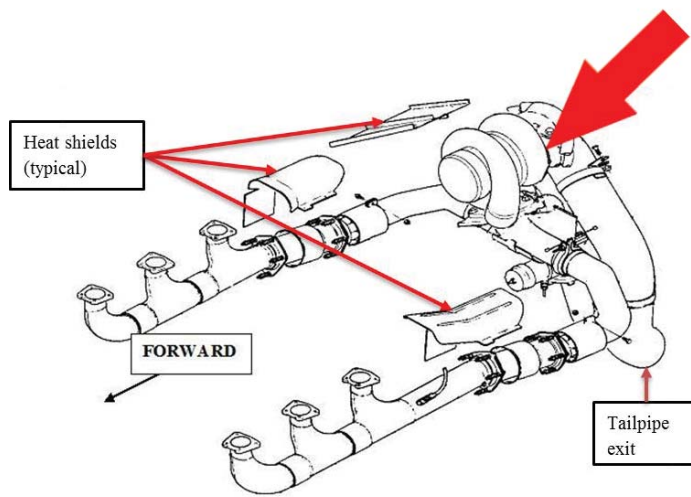
On the next page is a twin turbocharged engine airplane with an engine with top exhaust ports. The lower red arrow denotes the large tailpipe, and the circular housing just inboard of the tailpipe is the turbocharger which in this application is under a heat insulation blanket. The upper blue arrow points to the threaded end of the T-bolt of the multi-segment V-band coupling attaching the tailpipe to the turbocharger. On this type of turbocharger installation, you may see more of the turbocharger and heat protection features when the cowling is removed for an annual/100-hr. inspection. However, even then one would be hard pressed to find a crack anywhere along the multi-segment, V-band coupling, V-retainer inner surface when installed.



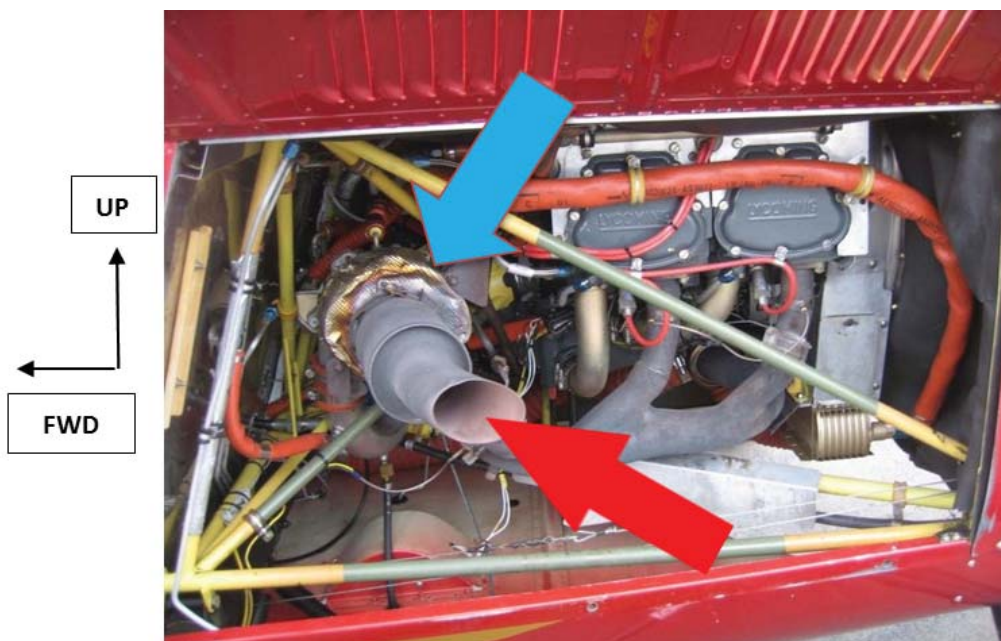
Another twin engine airplane, this one with engine cylinders incorporating bottom exhaust ports is depicted below. The lower red arrow denotes the large tailpipe entrance. The circular housing just inboard of the tailpipe is the turbocharger under a heat shield and insulation blanket, denoted by the upper blue arrow.



Below is a diagram of a typical full exhaust system for a twin engine airplane utilizing engine cylinders with bottom exhaust ports. The large red arrow would be the tailpipe coupling or clamp location. Some of the heat protection features are also shown therein.



And finally, depicted below is a turbocharged engine used in a rotorcraft application with a LH forward turbocharger installation. The engine has cylinders with bottom exhaust ports. The hinged upper cowling door is open. The lower red arrow denotes the tailpipe/muffler assembly which is connected directly to the turbocharger exhaust exit flange just inboard of the muffler body on the tailpipe. The upper blue arrow points to the tailpipe multi-segment, V-band coupling just in front of the turbocharger heat insulation blanket. This type of installation may allow a very good pre-flight inspection of the tailpipe and coupling.





### 1.2.2 Turbochargers (typical)

The photograph below is a typical new or freshly overhauled turbocharger assembly. The red arrow denotes the turbocharger exhaust exit flange where the tailpipe mates and is subsequently secured via a V-band coupling/clamp which is not shown in the photograph below. The tailpipe is attached to that flange on the RH cast iron side of the assembled turbocharger. The coupling that is shown below on the LH side of the turbocharger is used in this application to attach the compressor housing side of the turbocharger, which is not part of this Best Practice Guide. You will note that the exit flange is flush or already within the cast iron housings envelope. The upstream area of the exit flange is even further within that envelope. This is typical of the standard turbocharger found on many legacy aircraft products.



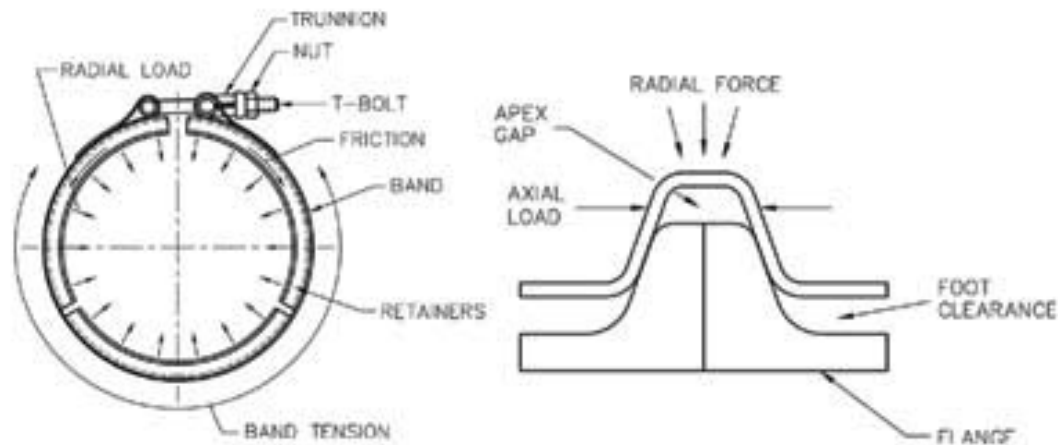
Another turbocharger assembly is depicted on the next page (looking at the exhaust end on the bench). This version has the tailpipe (with a wastegate pipe and valve installed) installed on the turbocharger exhaust exit with a V-band coupling. The tailpipe is denoted by the upper red arrow and the multi-segment, V-band coupling is denoted by the lower blue arrow. Finally, even with the turbocharger assembly on the bench, a thorough inspection of the V-band coupling as installed is difficult. It is unlikely that one would be able to assess the interior of the coupling in hopes of finding a crack that lurks in a V-retainer inner radius on the coupling



As can be seen above in the variety of installation configurations and turbocharger assemblies, the turbocharger to tailpipe interface and V-band coupling/clamp are not readily visible. Unfortunately, the necessary heat protection features of the DAH type design (i.e. insulation blankets and heat shields) work well to obscure visibility of the turbocharger and V-band coupling/clamp and removal of those features has its own concerns. The interface to the turbocharger housing is also such that the coupling/clamp resides within the turbochargers cast iron housing envelope. Seeing the backside of the installed coupling/clamp is not readily accomplished, even with a bright light and mirror, and viewing the interior of the V-retainers is impossible. Therefore, it is understandable how things might be missed during an installation inspection. There are also valid concerns that come with the repetitive removal of the coupling/clamp which were not foreseen. However, that is to be expected anytime significant inspection or maintenance is accomplished, and that alone should not preclude anyone from performing a thorough inspection of the V-band coupling/clamp.

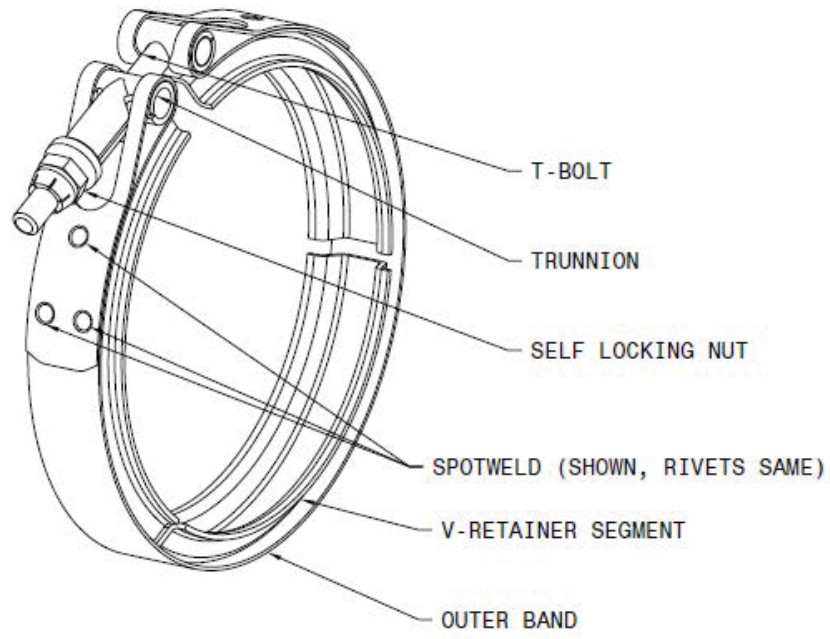
## 2.0 COUPLING & CLAMP DESIGN

All turbocharger exhaust tailpipe V-band couplings or clamps are intended to couple and retain the exhaust tailpipe to the turbocharger housing, exhaust exit flange. The exhaust tailpipe V-band coupling/clamp does this by converting the radial load of the coupling band tension or clamp body to an axial load on the flanges due to the wedging action of the 'V' retainer segments or clamp body itself, as shown below.

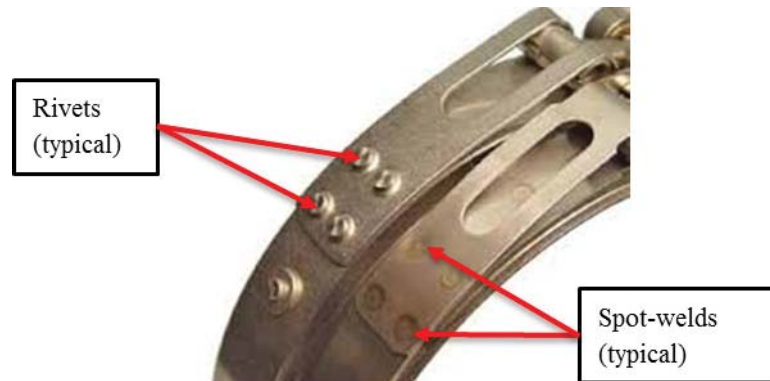


There are two types of exhaust tailpipe V-band coupling and one type of V-band clamp used to join the exhaust tailpipe to the turbocharger exhaust exit flange. The two types of V-band couplings are spot-welded, multi-segment V-band couplings and riveted, multi-segment V-band couplings. The one type of V-band clamp is called a single-piece V-band clamp. There are very distinct differences between the types and their installations are not interchangeable per the applicable aircraft, engine or part Design Approval Holder (DAH), unless FAA approved. The following briefly explains the distinct differences in couplings and clamps.

Multi-Segment, V-band *Couplings* come in two varieties: spot-welded and riveted (aka; collared fastener). The two varieties typify the method of joining of the outer flat band to the inner V-retainer segments, and all other metal-to-metal joints on the coupling. In this application, the couplings come in either two or three segment varieties. The segments are the number of V-retainer segments, which are attached to the outer band via spot-welds or rivets. Materials used throughout are various stainless steel alloys or Inconel's. The single-piece T-bolt may be straight or have a manufactured bend at the 'T' head by design. Couplings may also have a quick release latch to capture the T-bolt head. The self-locking nut is typically a high temperature steel alloy that is often silver coated. The self-locking nut is all-metal and the locking feature is a mechanical interference type with no polymer inserts. Couplings typically do not use washers under the nut as the trunnion housing is formed flat to act as a washer surface for the nut. Refer to Figures 1 thru 6 on the following pages.



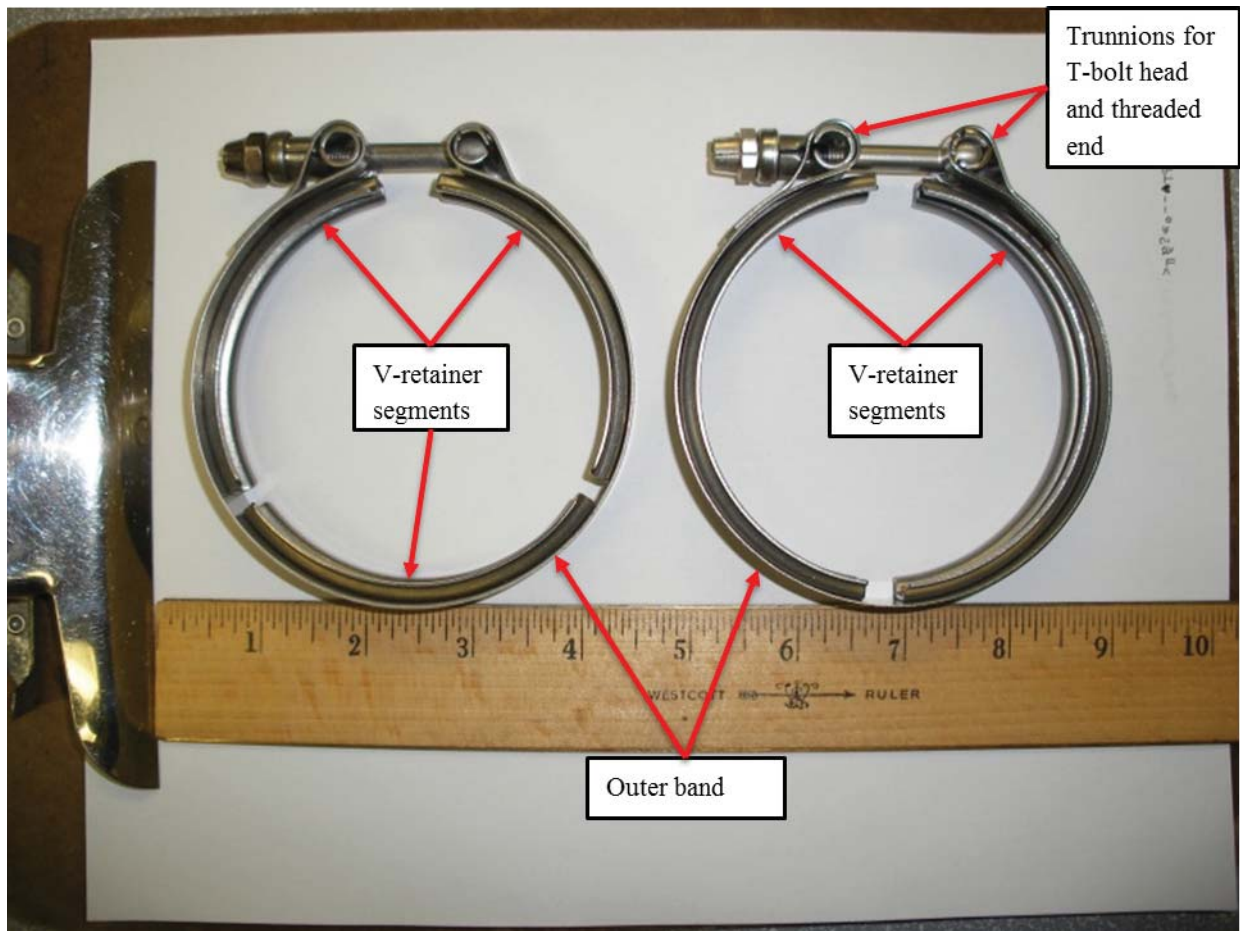
**Figure 1**  
**Multi-Segment, V-band Coupling**  
**3-segment**



**Figure 2**  
**Multi-Segment, V-band Couplings**  
**LH riveted (aka, collared fastener) & RH spot-welded**

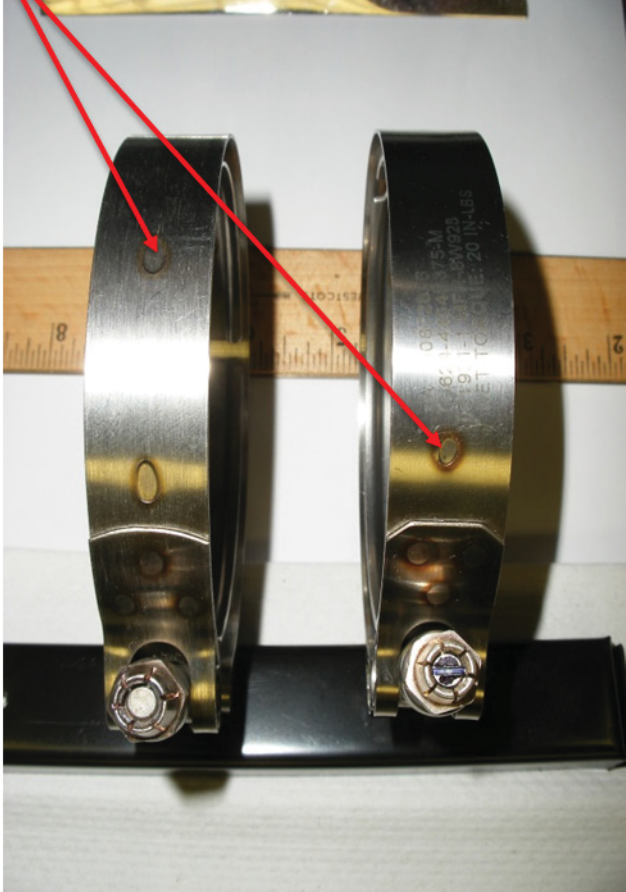
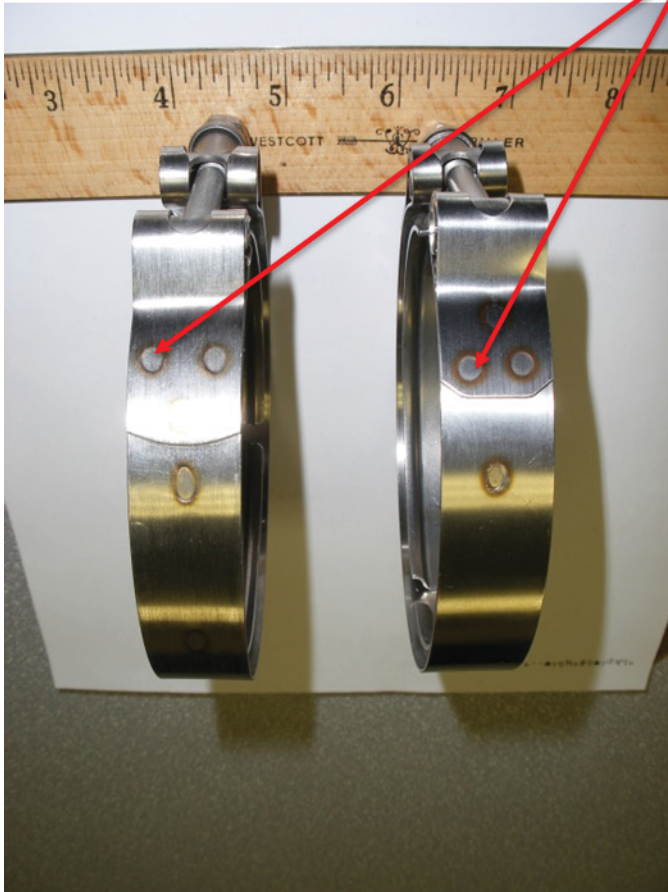
Although not as widely used as the spot-welded, multi-segment V-band couplings, riveted (aka; collared fastener) multi-segment, V-band couplings are approved on various make/model aircraft. A riveted coupling is almost identical with the exception of spot-welds being replaced with a similar number of rivets or collared fasteners to join the materials. Refer to Figure 1, 2, and 6.

**NOTE:** Spot-welded and riveted couplings may look identical in all respects except the manufacturing method and may come in the exact same size and flange configuration as a similar spot-welded or riveted coupling. However, the couplings may or may not be legally interchangeable without an aircraft, engine or part FAA approval at the DAH level. Likewise, for a single-piece clamp versus any coupling type, these are also not interchangeable unless FAA approved in some manner as identified above.



**Figure 3**  
**Spot-Welded, Multi-Segment, V-band Couplings**  
**3-segment LH                      2-segment RH**  
**3.750-inch size**

Spot-welds (typical)  
Rivets would be in similar  
locations



**Figure 4**  
View looking at T-bolt head trunnion end

**Figure 5**  
View looking at lock-nut trunnion end

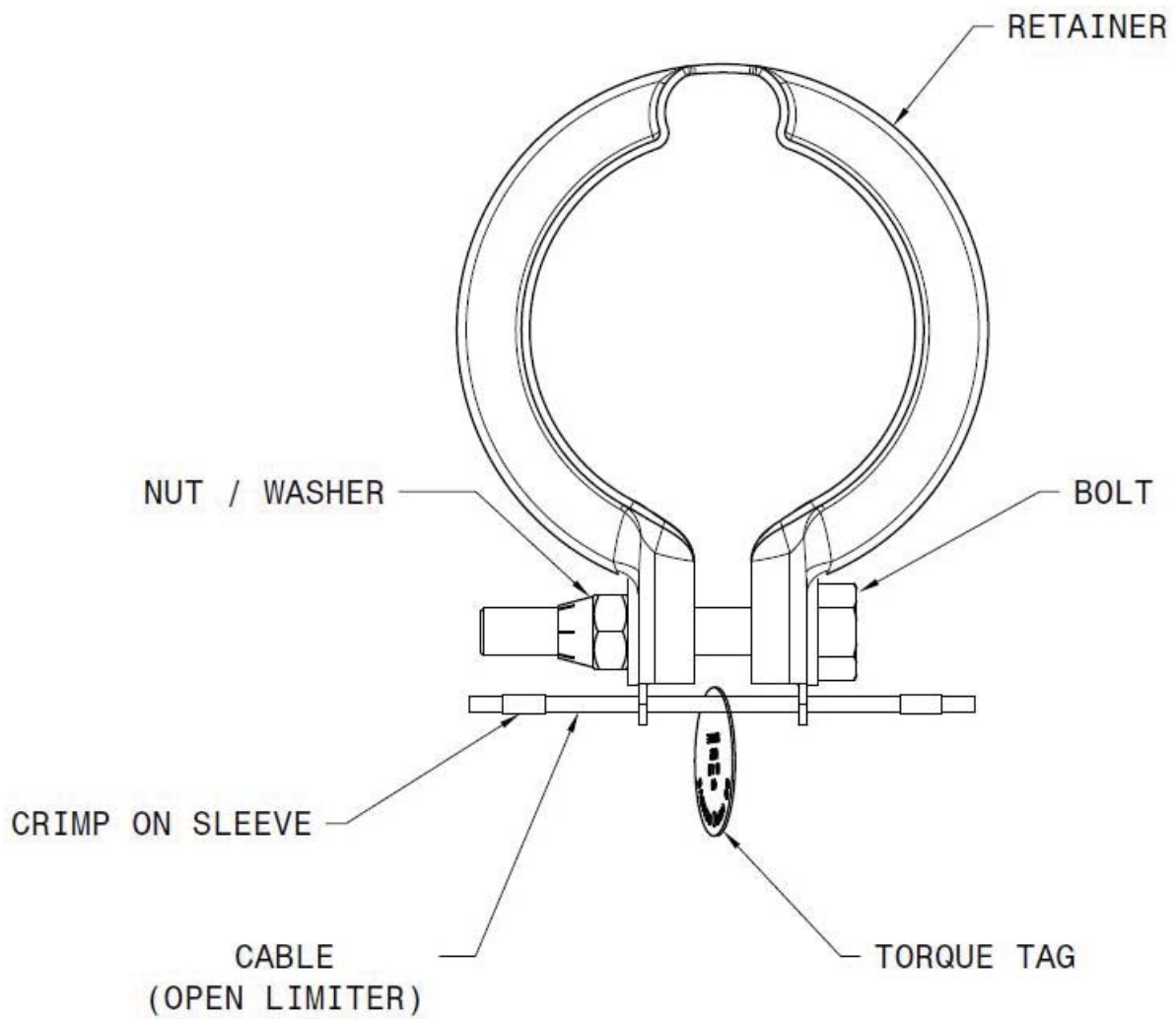
**Spot-Welding, Multi-Segment, V-band Couplings**

3.750-inch size



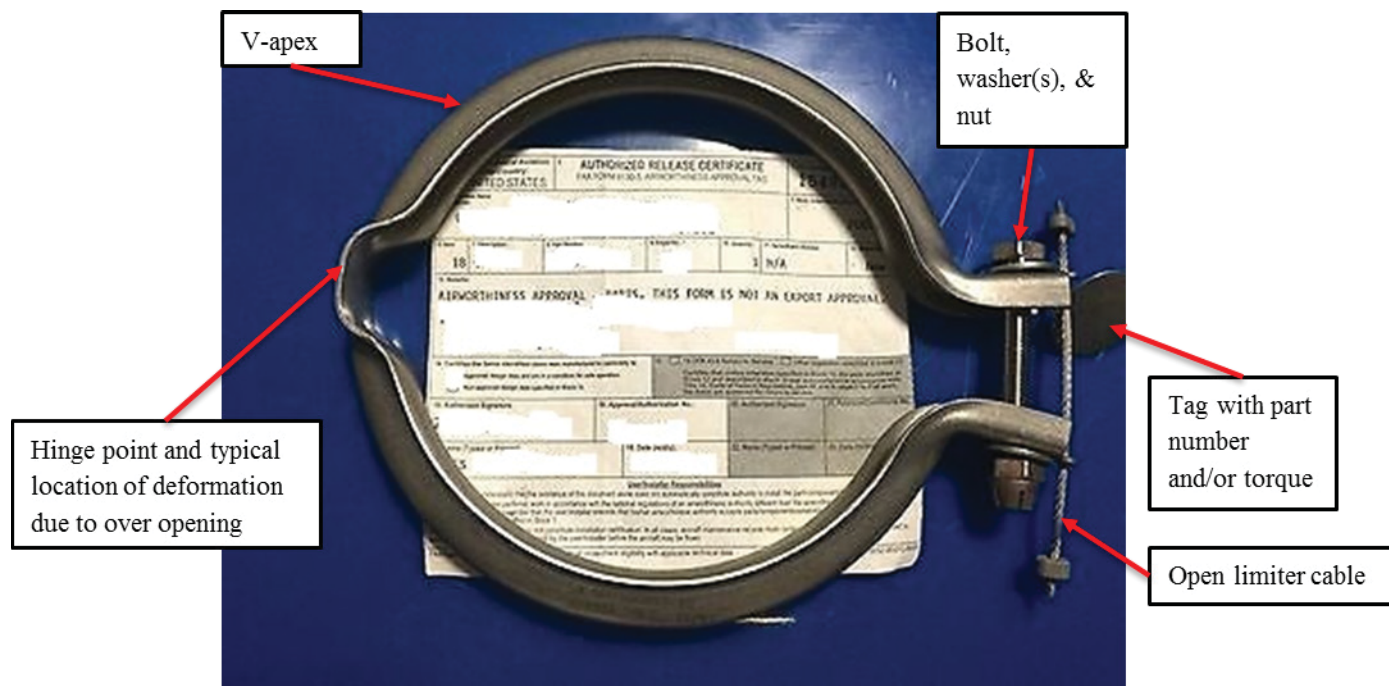
**Figure 6**  
**Riveted (aka, Collared Fastener), Multi-Segment, V-band Coupling, 3-Segment,**  
**Unknown size**

Single-Piece, V-band *Clamps* are stamped and roll formed from one single-piece of base material. Materials used throughout are various stainless steel alloys or Inconel's. The single-piece straight (only) bolt is a stainless steel alloy. The self-locking nut is typically a high temperature steel alloy that is often silver coated. The self-locking nut is all-metal and the locking feature is a mechanical interference type with no polymer inserts. There is typically one washer under the bolt head and one washer under the nut on these clamps. They also typically come with a cable across the open end which acts as an open limiter. Installed on that cable there can be a tag with torque and/or part number and a pair of crimped on sleeves to limit opening. Lack of the cable, torque tag and/or crimp(s) (if applicable to the p/n) that appear replaced should make the clamp suspect. Refer to Figure 7 and 8.



**Figure 7**  
**Single-Piece, V-band Clamp**





**Figure 8**  
**Single-Piece, V-band Clamp**

**NOTE:** As noted above for multi-segment couplings, single-piece clamps may come in the exact same size and flange configuration and may look identical in all respects. However, clamps and any type of coupling may or may not be legally interchangeable without an aircraft, engine or part FAA approval at the DAH level.

### **3.0 INSTALLATION [Refer to Section 1.2.1 and Figures 1, 7, 9-14, 16 & 17]**

#### **3.1 Methods**

The specific focus area of this Best Practice Guide are those V-band couplings and clamps used at the turbocharger exhaust exit to exhaust tailpipe interface only. However, the installation recommendations herein may be applicable to any V-band coupling or clamp in any aircrafts exhaust system.

#### **CAUTION**

SUBSTITUTION OF A COUPLING/CLAMP PART NUMBER, AND/OR TYPE (SPOT-WELDED, RIVETED, OR SINGLE-PIECE) FOR ANOTHER COUPLING OR A CLAMP OR VICE VERSA IS NOT ALLOWED WITHOUT A SPECIFIC FAA APPROVAL FROM THE DAH.

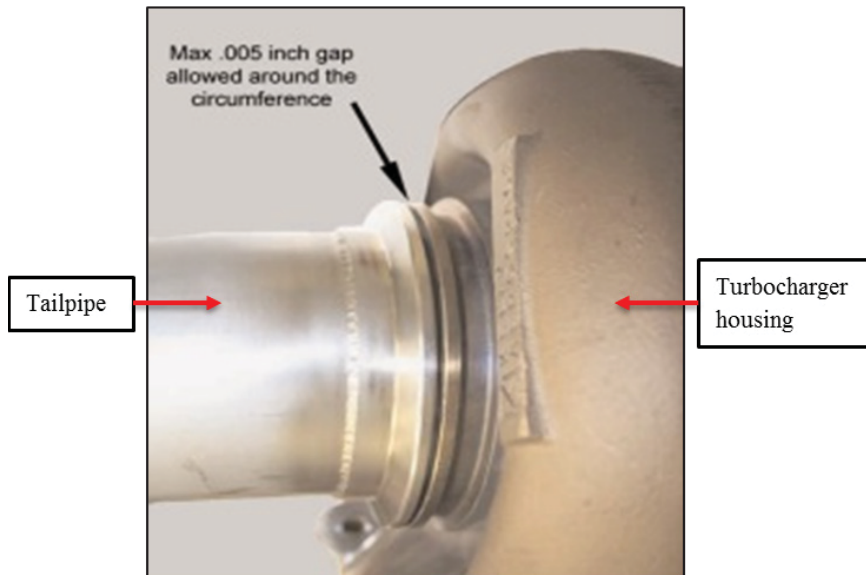
#### **CAUTION**

NO SERVICE LIFE EXTENSION SHOULD BE PERMITTED, AND NO SERVICE LIFE EXTENSIONS ARE ALLOWED WHEN MANDATED BY AIRWORTHINESS DIRECTIVE (AD) WITHOUT AN FAA APPROVED ALTERNATE METHOD OF COMPLIANCE (AMOC) TO THE SPECIFIC AD. ALSO CHECK THE AIRWORTHINESS LIMITATIONS.

### **WARNING**

CRACKS AS WELL AS INCORRECT ASSEMBLY OR INSTALLATION OF THE TURBOCHARGER EXHAUST SYSTEM CAN ADVERSELY AFFECT ENGINE OPERATION, OR RESULT IN RELEASE OF HOT AND TOXIC GASES, WHICH CAN CAUSE DAMAGE TO NEARBY COMPONENTS, SYSTEMS OR A FIRE.

Inspect the turbocharger exhaust exit flange and the exhaust tailpipe flange interfaces for any un-flat (0.005 in. or greater) or wavy condition, corrosion, pitting, scaling or deposits (not easily removed) and correct per the manufacturer's recommendations. Refer to Figure 9.



**Figure 9**

**Typical turbocharger exhaust exit flange to tailpipe interface**

### **CAUTION**

USE CARE TO SUPPORT THE ENTIRE EXHAUST SYSTEM DURING INSTALLATION. DO NOT FORCE, PRY, OR BEND COMPONENTS DURING FINAL ALIGNMENT TO PREVENT DAMAGE TO THE PARTS.

### **CAUTION**

THE SELF LOCKING NUT MUST HAVE A RUNNING TORQUE OF 1.8 TO 30.0 INCH-LBS. THE NUT SHOULD BE CAPABLE OF MULTIPLE ON-OFF CYCLES (MAXIMUM 10). HOWEVER, THAT IS VERY DEPENDENT ON THE NUT AND BOLT CONDITION(S), DEPOSITS, CONTAMINATION, ETC.

- a. Conduct the installation when the engine is cool.
- b. Prior to installation, ensure the coupling/clamp and attaching hardware is free from any physical damage to include but not limited to; cracks, gouges, tears, bulges and fractures.
- c. Prior to installation, ensure the tailpipe and turbocharger exhaust exit flange are free from cracks, warps, gouges, nicks, grease dirt or deposits, including all weld areas. Refer to Figures 9 & 17.

### **CAUTION**

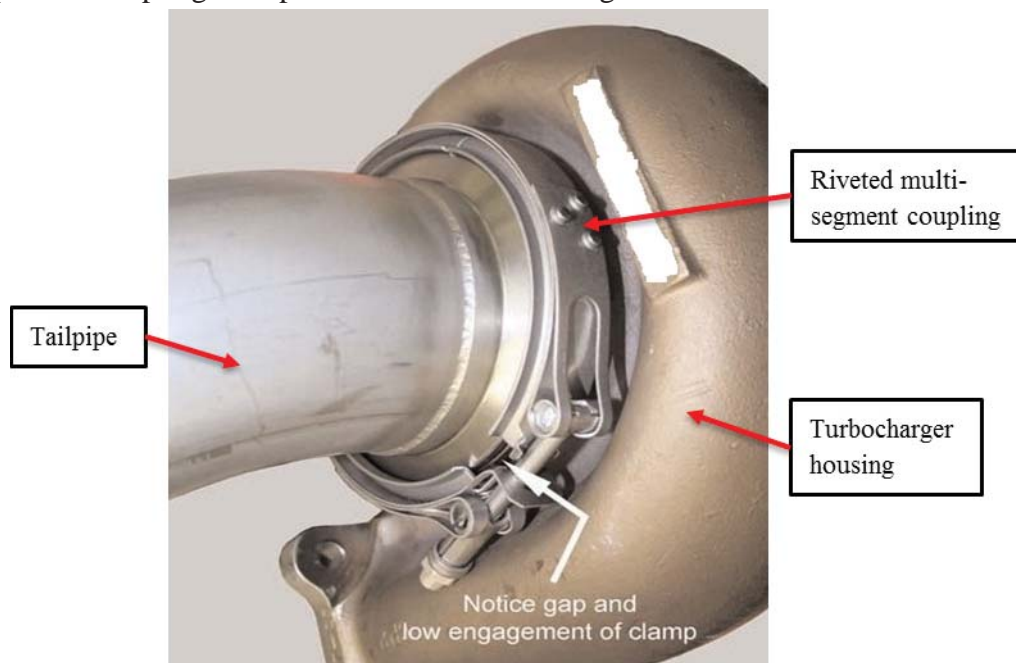
WHEN INSTALLING EXHAUST SYSTEM COMPONENTS, INITIALLY TIGHTEN HARDWARE FASTENERS FINGER-TIGHT. ENSURE ALL COMPONENTS ARE ALIGNED PROPERLY BEFORE APPLYING FINAL TORQUE TO FASTENERS.

- d. Assemble all tailpipe and interface exhaust components (i.e.; wastegate), hangers and supports loosely in order to receive final torque.

### **CAUTION**

DURING ANY INSTALLATION, DO NOT TWIST OR OPEN THE COUPLING/CLAMP MORE THAN NECESSARY BECAUSE OVER-OPENING OR EXCESSIVE FLEXING CAN LEAD TO PHYSICAL DAMAGE, INEFFECTIVE SEALING AND EXHAUST GAS LEAKAGE. DO NOT OVER STRETCH OR OPEN BY PULLING THE SIDES APART ON ANY COUPLING/CLAMP.

- e. Assemble the tailpipe exhaust flange on to the turbocharger exhaust flange, with a new gasket if applicable per the DAH type design configuration or current Instructions for Continued Airworthiness (ICA). Carefully twist the coupling/clamp over the flanges as if to follow the flanges as a nut would on a screw thread. Refer to Figure 10.
- f. Ensure alignment of tailpipe flange and turbo exhaust exit flange with no gaps (maximum 0.005 in.), prior to coupling/clamp installation. Refer to Figure 9 & 10.



**Figure 10**

**Typical installation of tailpipe and V-band coupling on turbocharger exhaust flange**

### **CAUTION**

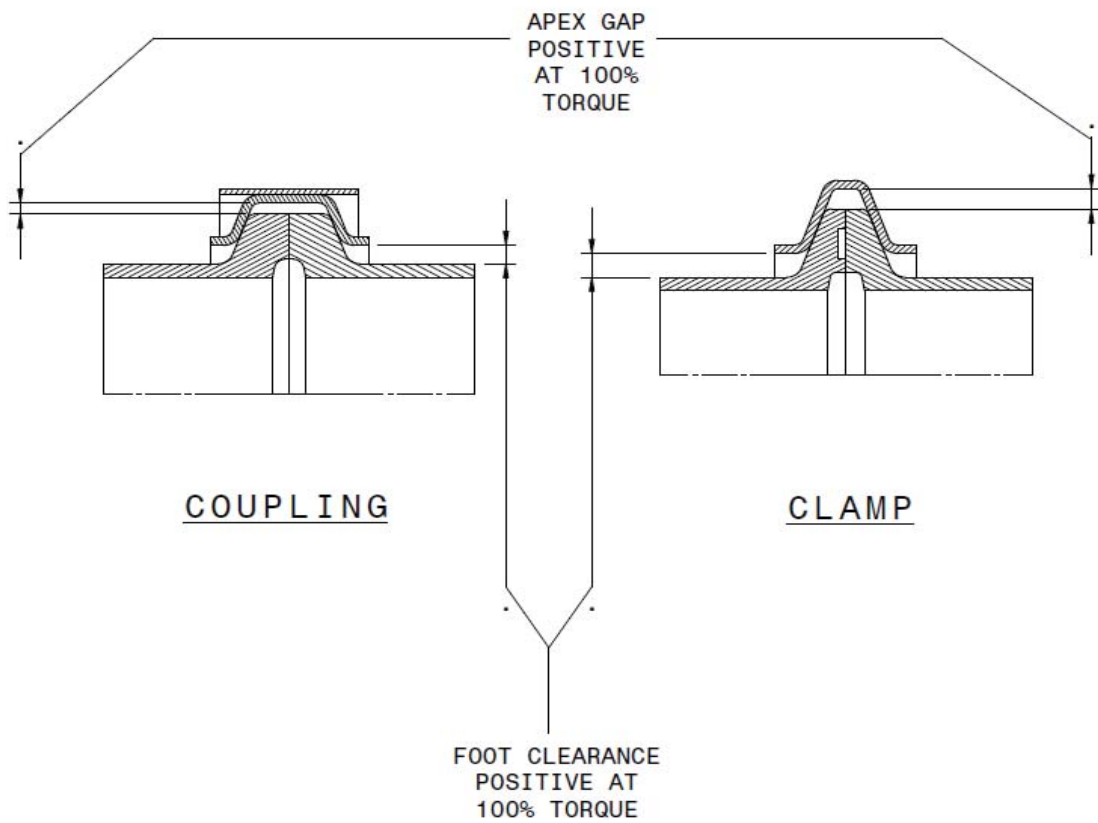
WE DON'T RECOMMEND THE USE OF POWERED TOOLS. HOWEVER, IF USING A POWERED DEVICE TO INSTALL THE LOCKNUT DO NOT INSTALL AT GREATER THAN 120 RPM. EXCESSIVE NUT INSTALLATION SPEED CAN CAUSE THREAD DAMAGE AND INCORRECT FINAL TORQUE.

- g. Preload 50-70% of total V-band coupling/clamp required final torque value, then if possible, lightly tap (not trying to deform) the coupling/clamp around the periphery with a soft faced mallet to ensure proper seating and even distribution of clamping stress. Do not rely on tightening alone for proper coupling/clamp seating.

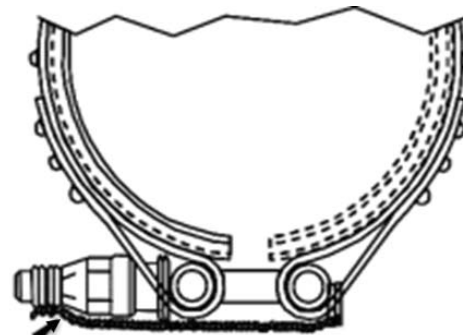
### **CAUTION**

THE COUPLING/CLAMP AT THE TURBOCHARGER EXHAUST EXIT FLANGE MUST BE CORRECTLY ALIGNED TO THE TAILPIPE FLANGE. **DO NOT USE THE V-BAND COUPLING/CLAMP TO BRING THE EXHAUST COMPONENTS INTO ALIGNMENT.** INCORRECT ALIGNMENT OF THE COUPLING/CLAMP IS AN INDICATION THAT THE EXHAUST SYSTEM IS NOT CORRECTLY INSTALLED. IF THE COUPLING/CLAMP DOES NOT ALIGN, ADJUST THE EXHAUST SYSTEM COMPONENTS UNTIL THE COUPLING/CLAMP IS IN CORRECT ALIGNMENT. A SLIGHT ADJUSTMENT TO THE TURBOCHARGER ORIENTATION MAY ALSO PERMIT CORRECT COUPLING/CLAMP ALIGNMENT.

- h. Make sure there are no gaps at other exhaust system connections and all exhaust system components are correctly aligned before the final torque of all the exhaust system hardware.
- i. Refer to the applicable DAH ICA's and their latest revisions for correct torque requirements for all exhaust system V-band coupling/clamps.
- j. Ensure the turbocharger exhaust exit flange and exhaust tailpipe flanges are aligned, and then apply final, total 100% torque. Do not over-torque in an attempt to get things to fit together. If at 100% torque tailpipe fit is incorrect, disassemble the exhaust system as needed to determine the cause of the problem and correct it prior to proceeding with the installation.
- k. Check the coupling V-retainer and clamp V-band apex gap and foot clearances. At full torque, a positive clearance must be maintained throughout to prevent the coupling/clamp from bottoming out on the flanges before the required loading has been achieved. Refer to Figure 11.
- l. We recommend safety wire (minimum 0.032 in. stainless steel) per acceptable methods the bolt head to the nut end trunnion of the coupling as applicable to preclude opening of the coupling if the bolt or nut loosens, fails, or separates from the mating fastener after installation. Refer to Figures 12 & 13.
- m. Properly install and torque as applicable the remaining exhaust system components, support clamps, hangers, and associated hardware.

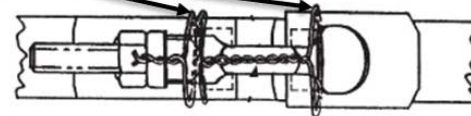


**Figure 11**  
Coupling & Clamp Installation Clearances



**Figure 12**  
Multi-Segment, Coupling Safety Wired

Safety wire



**Figure 13**  
Multi-Segment, Coupling Safety Wired

- n. After a coupling/clamp is installed/reinstalled and fully torqued, verify there is space between each V-retainer coupling segment, or verify there is space between both ends of a clamp. If there is no space between the V-retainer segment ends or clamp ends, a new coupling/clamp should be installed prior to further flight. Refer to Figures 14 & 16.
- o. After a coupling/clamp is installed/reinstalled and fully torqued, check the coupling V-retainer and clamp V-band apex gap and foot clearances. A positive clearance must be maintained throughout to prevent the coupling/clamp bottoming out on the flanges. If there is no clearance in either location, a new coupling/clamp should be installed prior to further flight. Refer to Figure 11.
- p. Relocate or reinstall any systems, cowling or access panels that have been previously removed.
- q. After installation of any coupling/clamp, conduct an engine ground run with a full heating and cool down cycle and recheck the torque of the coupling/clamp after the engine has cooled. Adjust as necessary per Section 3.
- r. Anytime a coupling/clamp is replaced with a new coupling/clamp, a record should be made in the maintenance records to include date of installation, the Time-In-Service (TIS) of the new coupling/clamp, manufacturer and part number.
- s. Recheck the torque on any new or re-installed coupling/clamp after 25 hours TIS.

### 3.2 Tips & Hints

The following is a summary of some good do's and don'ts for V-band coupling/clamp installation:

- a. Installation and fitment of components which are all new is often much better than a mix of old or worn components and new components.
- b. Always minimize gaps and misalignment and align exhaust components prior to installation.
- c. Soft-fit all components (including support brackets and clamps) loosely to assist in proper alignment and tailpipe support to preclude pre-loading the coupling/clamp inadvertently.
- d. Do not attempt to align things using the coupling/clamp alone, get assistance from someone.
- e. Ensure all required seals or gaskets as applicable (per the DAH ICA's) are airworthy and in their proper position.
- f. Ensure the self-locking nuts are still serviceable and retain their locking capability, otherwise replace them.
- g. Minimize opening, twisting or cycling of the coupling/clamp at any time.
- h. Use of a hi-temp, nickel based, anti-seize compound on all interfaces may assist in the initial installation process.
- i. Properly seat the coupling/clamp evenly around its circumference while tightening up exhaust installation fasteners (tailpipe, supports, hanger, etc.).
- j. If accessible, a tap around the circumference with a soft mallet while tightening may help seat the coupling/clamp
- k. Apply the proper torque as defined by the DAH Instructions for Continued Airworthiness.
- l. More torque and subsequent over-torque is not better and will lead to deformation of the coupling/clamp and reduced service life.
- m. In marine or saltwater environments or operations, be sure to include the V-band coupling/clamp in your airplane/engine washes and enhanced inspection programs.
- n. If using blast media for cleaning a coupling/clamp, use only blast media that is non-abrasive, non-ablative and non-peening when cleaning any coupling/clamp per approved or acceptable methods.

## 4.0 INSPECTIONS

The specific focus area of this Best Practice Guide are those V-band couplings and clamps used at the turbocharger exhaust exit to exhaust tailpipe interface only. However, the inspection recommendations herein may be applicable to any V-band coupling or clamp in any aircrafts exhaust system.

### **WARNING**

NEVER USE HIGHLY FLAMMABLE SOLVENTS ON ENGINE EXHAUST SYSTEMS. NEVER USE A WIRE BRUSH OR ABRASIVES TO CLEAN EXHAUST SYSTEMS. DO NOT USE ETCH TOOLS, GRAPHITE LEAD PENCIL, OR SCRIBE TO APPLY AN IDENTIFIER MARK ON EXHAUST PIPES. USE A NON-GRAPHITE MARKER.

### **CAUTION**

DURING ANY INSPECTION OR REMOVAL, DO NOT TWIST OR OPEN THE COUPLING/CLAMP MORE THAN NECESSARY BECAUSE OVER-OPENING OR EXCESSIVE FLEXING CAN LEAD TO PHYSICAL DAMAGE. DO NOT OVER STRETCH OR OPEN BY PULLING SIDES APART ON ANY COUPLING/CLAMP.

If the coupling/clamp is removed, inspect the turbocharger exit flange and the tailpipe flange interfaces for any un-flat (0.005 in. or greater) or wavy condition, corrosion or deposits (not easily removed) and correct per the manufacturer's recommendations. Refer to Figure 9.

### **4.1 Installed Inspection - Coupling/Clamp Installed**

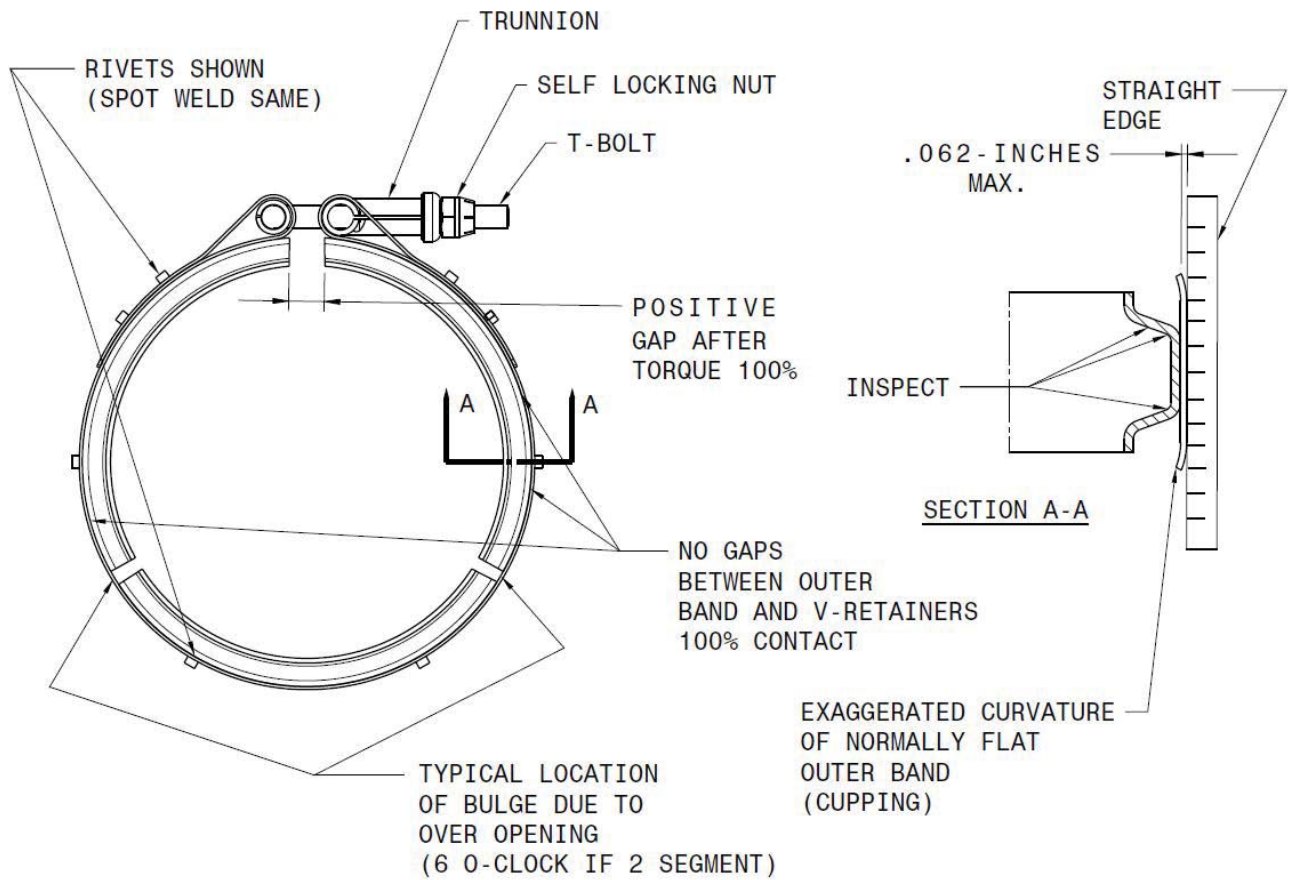
[Refer to Sections 1.2.1 and 5, and Figures 1 through 17]

The goal of the inspections is to find any of the Unsatisfactory Conditions presented in Section 5. These procedures do not require removal of the coupling/clamp, unless an Unsatisfactory Condition as defined in Section 5 is found or perceived to exist on any installed coupling/clamp. Conduct the inspection when the engine is cool.

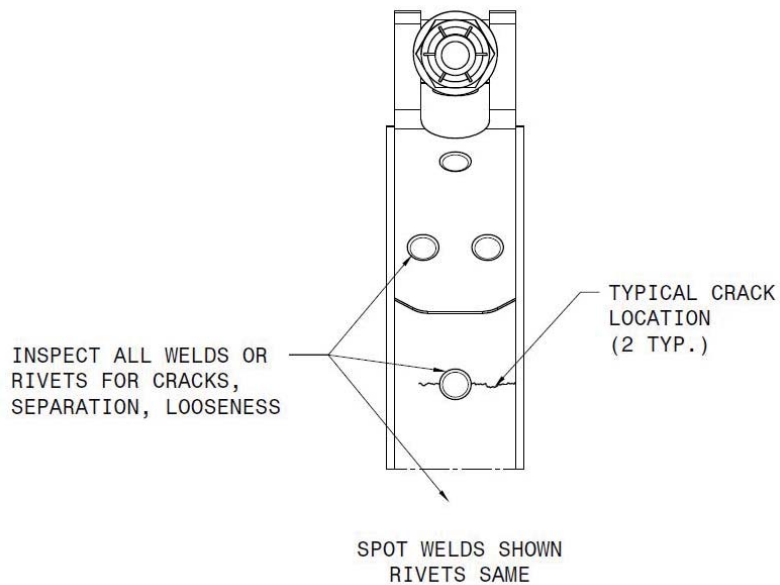
- a. First, inspect the turbocharger, tailpipe, and surrounding area in the as-received, installed condition. An inspection of the installed turbocharger area and surroundings may reveal Unsatisfactory Condition(s) or other issues with the installation such as sooting, signs of overheating, etc., that may be lost after a cleaning.
- b. Remove any access panels or engine cowling as necessary to gain access and visibility to the installed turbocharger and tailpipe.
- c. Remove any heat shields, insulation blankets, and any other readily removable exhaust system components that facilitate a better view of the exhaust tailpipe installation.
- d. Loosen and/or relocate or remove any other systems that may impede your ability to inspect the tailpipe V-band coupling/clamp.
- e. First check the installed torque of the self-locking nut to be sure it is to type design per the DAH ICA's and ensure there is no free-play in the coupling/clamp as received. If not torqued



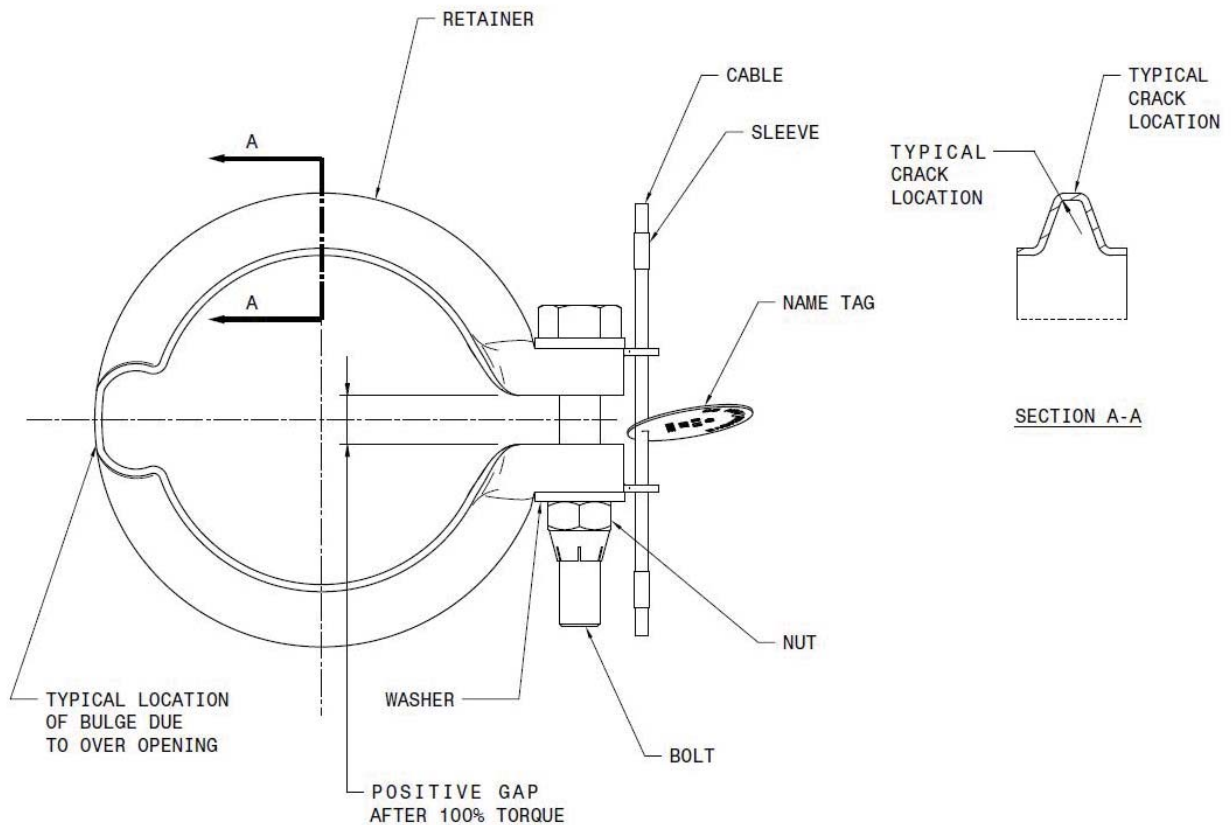
- properly, this may explain movement at the tailpipe to turbocharger interface and potential wear marks on the V-retainers or V-band clamp body itself when the coupling/clamp is removed. This check may also reveal the condition of the self-locking nut and its ability to remain self-locking. If in doubt, about the nuts capability, replace the nut.
- f. Use a bright light and mirror to inspect the areas that cannot be seen directly. Refer to Section 1.2.1 and Figures 14-17, 19, 21-23, 26, & 27. Pay particular attention to and carefully inspect the hard-to-see areas where the tailpipe attaches to the turbocharger exhaust exit flange. Inspect surrounding area for signs of exhaust stains, sooting or other evidence of exhaust leakage. These are grounds for removing the coupling/clamp and performing the Uninstalled Inspection per Section 4.2 herein.
  - g. Thereafter, if required, clean engine exhaust components per acceptable or approved methods using acceptable or approved materials. Pay particular attention to the outer band (flat) of a multi-segment V-band coupling, specifically at or near any spot-weld or rivet, and the outer surface of the V-band on a single-piece clamp. Refer to Figures 14-17, 19, 21-23, 26 & 27.
  - h. With the coupling/clamp properly torqued, visually inspect looking for any Unsatisfactory Condition as defined in Section 5. Refer to Figures 11, 14, 16 & 17.



**Figure 14**  
**Multi-Segment, V-band Coupling**



**Figure 15**  
**Multi-Segment, V-band Coupling**



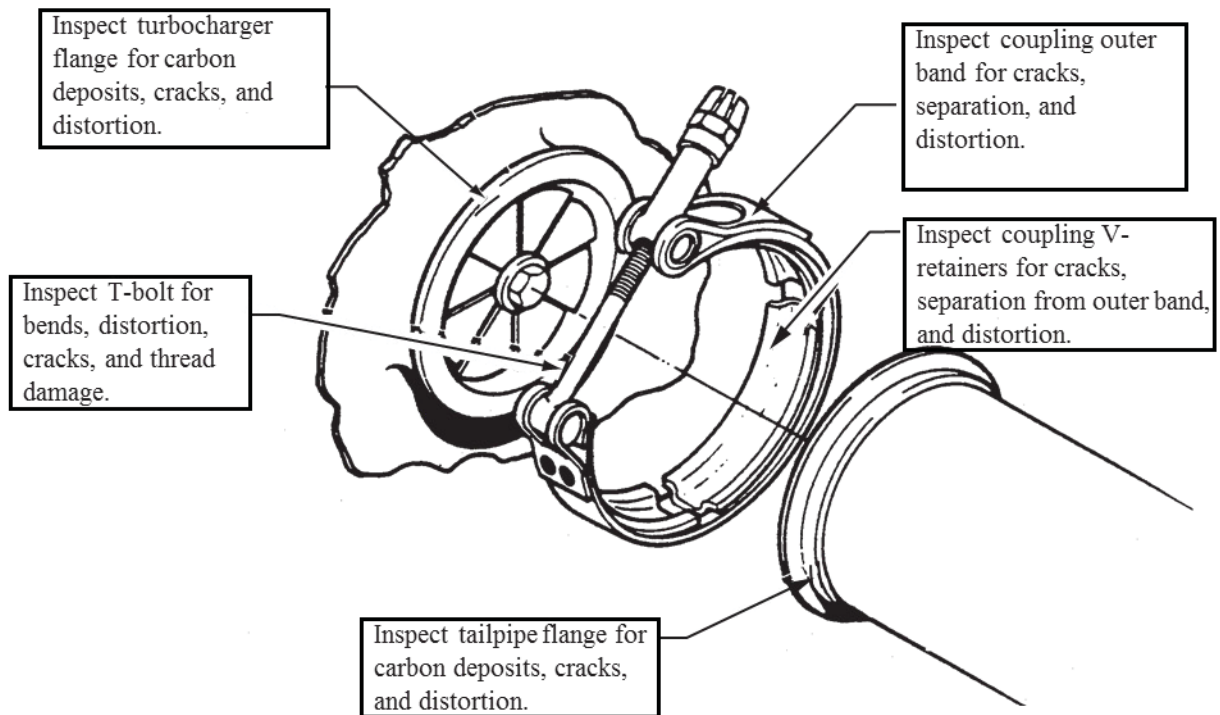
**Figure 16**  
**Single-Piece, V-band Clamp**

**4.2 Uninstalled Inspection - Coupling/Clamp In-hand**

[Refer to Figures 1-8, 14-17, 19, 21-23, & 25-27.]

The goal of the inspections is to find any of the Unsatisfactory Conditions presented in Section 5. If the coupling/clamp has been removed for any reason, perform the following more detailed Uninstalled Inspection:

- a. Hereafter, if required, clean engine exhaust components per acceptable or approved methods using acceptable or approved materials. Pay particular attention to the outer band (flat) of a multi-segment V-band coupling, specifically at or near any spot weld or rivet, and the outer surface of the V-band on a single-piece V-band clamp. Refer to Figures 4-6, 14-16, 19, 21-23, 26 & 27.
- b. Use a 10X magnifier and bright lighting, backlighting may also be useful. Refer to Figures 14-17, 19, 21-23 & 25-27. Pay particular attention to the spot-welds or riveted areas on multi-segment couplings and the outer surface of the V-band on single-piece V-band clamps and areas that are initially hard to get to or see as installed, as these may have been neglected in prior inspections and may harbor problems.



**Figure 17**  
**Typical Turbocharger to Tailpipe Interface Area**

- c. Visually inspect the coupling outer band for flatness using a straight edge. Lay the straight edge across the width of the outer band. The gap between the straight edge and the band must be less than 0.062 inches. Refer to Figure 14.
- d. With the T-bolt in the 12 o'clock position, visually inspect the coupling for the attachment of the outer band to the V-retainer coupling segments. Inspect for gaps between the outer band and the V-retainer coupling segments at or in between any spot-weld or rivet that holds the outer band to the V-retainers. Placing the light source on the backside of the coupling may make this assessment easier. Refer to Figure 14 & 15.
- e. Visually inspect the interior of the coupling V-retainers and the single-piece clamp V-band for indications of the exhaust flanges bottoming out in the V-apex of either. Refer to Figures 14, 16 & 25.
- f. Visually inspect the inner bend radii of the coupling V-retainer segments or clamp V-band for cracks. Inspect the radii throughout the length of the segments and clamp. Back-lighting may assist here. Refer to Figures 14, 16 & 25-27.
- g. Visually inspect the outer band and the V-retainer ends of a coupling or the V-band of any clamp opposite the bolt location (6 o'clock) for physical damage (i.e. distortion, creases, bulging, or cracks). Refer to Figures 14 & 16.

## 5.0 UNSATISFACTORY CONDITIONS

The following are definitions of Unsatisfactory Conditions for exhaust V-band couplings and clamps:

- a. Crack in the coupling outer band (flat) material, potentially at or near a spot-weld or rivet. Refer to Figures 1, 2, 4, 5, 6, 15, 19, 21, & 22.
- b. Cupping, bowing or crowning of the coupling outer band beyond 0.062 inches in depth. Refer to Figures 14, 19, 20 & 22.
- c. Crack in any coupling V-retainer segment interior or exterior surface, e.g. at corner radii. Refer to Figures 14 & 25.
- d. Looseness, separation of the outer band to V-retainer segment(s) at any spot-weld or rivet. Refer to Figures 14 & 15.
- e. Less than 100% contact (i.e. gaps) between the V-retainer segments and the outer band at or between spot-welds or rivets on a coupling. Refer to Figures 14.
- f. Crack in the clamp V-band exterior or interior surface along the V-apex, around the perimeter. Refer to Figures 16, 26 & 27.
- g. Clamp open limiter cable (if applicable to the specific part number of clamp) missing or detached. Refer to Figures 7, 8 & 16.
- h. Clamp part number and/or torque tag (if applicable to the specific part number of clamp) missing or detached. Refer to Figures 7, 8 & 16.
- i. Contact of the V-retainer segments ends or clamp ends at any location (e.g. bolt area). Refer to Figures 14 & 16.
- j. Lack of positive clearance at either the apex gap or foot clearance locations at full torque. Refer to Figure 11.
- k. Bolt shank bent, bowed, or deformed (not at the T-bolt head end, as there are some which are manufactured with a slight angle to it.)
- l. Bolt threads damaged or missing.
- m. Self-locking nut thread damage or a nut that has lost self-locking capability and can be installed without preload (i.e. less than a minimum running torque of 1.80 inch-lb.).
- n. Peening (flattening, curling) of material on the V-retainer segment ends or clamp ends from contact with each other, at any location (e.g. bolt area). Refer to Figures 14 & 16.
- o. Corrosion that is not easily removed with a polymer abrasive pad from any component of the coupling/clamp.
- p. Pitting of any component of the coupling/clamp base material.
- q. Permanent deformity to include, but not limited to, out of round, bowed or wavy condition (un-flat), twisted, and/or re-formed by any method.
- r. Physical damage to any coupling/clamp component to include but not limited to; cracks, gouges, notches, tears, bulges, bumps, fractures.
- s. Any repairs or any indications of past repairs.
- t. Unapproved hardware or any material or hardware substitution.

**NOTE:** It is understood that many of the unsatisfactory conditions above may not be readily accessed with the coupling/clamp installed. If coupling/clamp condition is suspect for *any* reason, you should always remove the coupling/clamp for a more detailed examination.

## 6.0 REPETITIVE INSPECTION & LIFE-LIMITING

### CAUTION

IF THERE EXISTS AN AIRWORTHINESS DIRECTIVE AGAINST THE PRODUCT WHICH ESTABLISHES A LIFE-LIMIT AND/OR REPETITIVE INSPECTION INTERVAL, THAT MANDATE TAKES PRECEDENCE OVER THE INFORMATION HEREIN, UNLESS APPROVED BY AMOC TO THE SPECIFIC AD. ALSO CHECK THE AIRWORTHINESS LIMITATIONS.

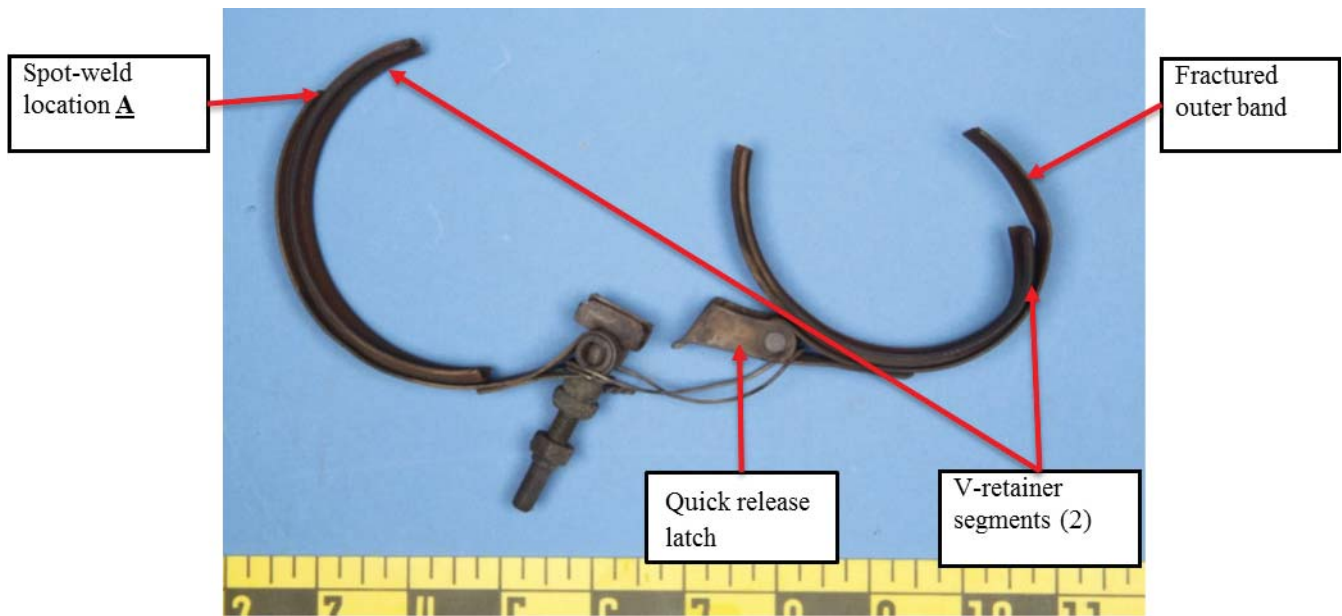
- a. Inspect annually the coupling/clamps per Section 4. The repetitive inspection may be conducted with the coupling/clamp installed per Section 4.1. If the installed condition is suspect or inspection or conditions indicate removal of the coupling/clamp is necessary to determine the coupling/clamp condition from the installed inspection, the coupling/clamp should always be removed and the inspection in Section 4.2 should be performed.
- b. Spot-welded, multi-segment V-band couplings should be life limited to 500 hrs. total TIS with no life extensions permitted.
- c. Riveted (collared fastener), multi-segment V-band couplings should be life limited to 2000 hrs. total TIS with no life extensions permitted.
- d. Single-piece V-band clamps should be life limited to 2000 hrs. total TIS with no extensions permitted.
- e. Coupling/clamp life limits are applicable to only one engine and aircraft installation and coupling/clamps should not be swapped between engines or aircraft or re-used in any other aircraft application.
- f. If any Unsatisfactory Conditions per Section 5 is found to exist on any coupling/clamp, the coupling/clamp should be considered un-airworthy and should be removed and replaced prior to further flight with a new, zero hours TIS, FAA approved coupling/clamp as applicable.
- g. Satisfactory completion of any inspection in Section 4 or the lack of finding any Unsatisfactory Condition as presented in Section 5 should not alter or terminate any repetitive inspection or restart the hours TIS for any coupling/clamp.
- h. If the coupling/clamp passes all of the inspections in Section 4, you should only re-install the same coupling/clamp on the same aircraft, engine, tailpipe and turbocharger combination from which the coupling/clamp was removed.
- i. After any coupling/clamp is re-installed on the same engine only and torqued as required per Section 3, verify there is space between the ends of each V-retainer coupling segment or between the ends of the clamp. If there is no space between any V-retainer coupling segment, or between the ends of the clamp, before further flight, you should install a new coupling/clamp and restart the hours TIS for the repetitive replacement of the coupling/clamp. Refer to Figures 11, 14 & 16.

- j. After a coupling/clamp is installed/reinstalled and fully torqued, check the coupling V-retainer and clamp V-band apex gap and foot clearances. A positive clearance must be maintained throughout to prevent the coupling/clamp bottoming out on the flanges. If there is no clearance in either location, a new coupling/clamp should be installed prior to further flight. Refer to Figure 11.
- k. If no Unsatisfactory Condition(s) per Section 5 are found the coupling/clamp, may remain installed or be re-installed on the same engine per Section 3 until the airworthiness condition of the coupling/clamp warrants the removal, the next inspection is due, or the TIS limits have been reached.
- l. Anytime a coupling/clamp is replaced with a new coupling/clamp, a record should be made in the maintenance records to include date of installation, the TIS of the new coupling/clamp, manufacturer and part number.
- m. All V-band coupling/clamps removed from service should be permanently destroyed and not used on any other engine, aircraft or other aircraft application.

## 7.0 V-BAND COUPLING & CLAMP FAILURES

### 7.1 Spot-welded, Multi-segment, Coupling Failures Encountered

Below are reference photographs of failed V-band couplings.



**Figure 18**

**Spot-welded, 2-segment Coupling with Quick Release Latch**

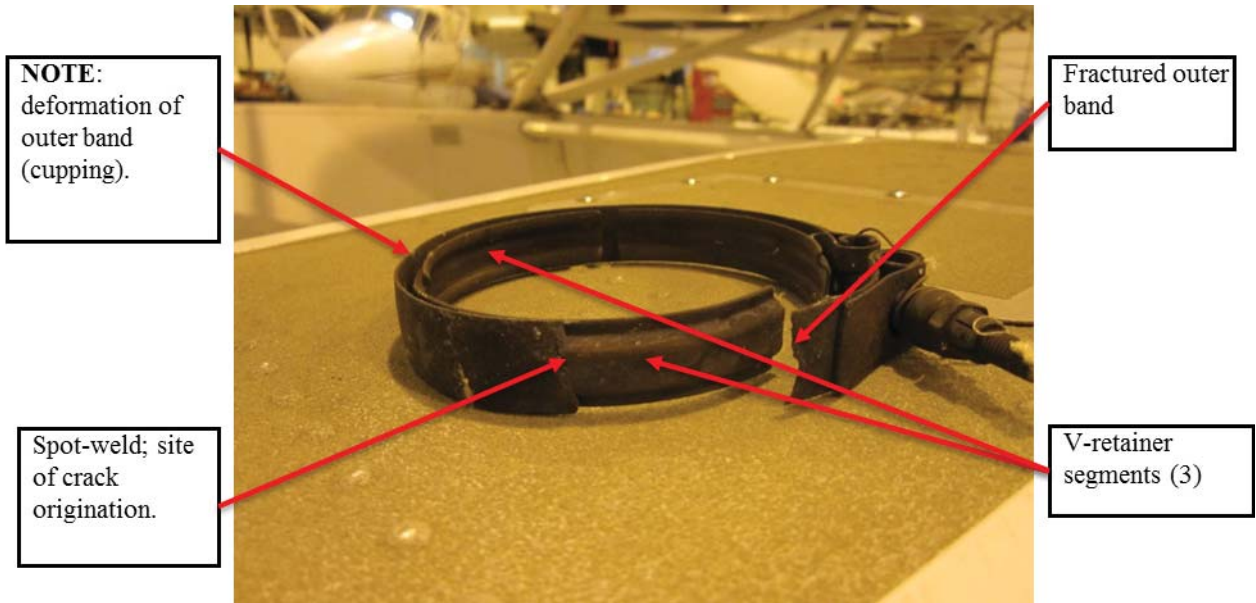


**Figure 19**

**Same coupling above magnified**

The above failure started as a crack that originated out of the spot-weld. The crack grew to a full transverse outer band crack that caused separation of the coupling. The above failure resulted in loss of the tailpipe, smoke in the cockpit, in-flight fire and fatalities. Note the safety wire is still in place.





**Figure 20**  
**Spot-welded, 3-segment Coupling**

The above failure started as a crack that originated out of the spot-weld. The crack grew to a full transverse outer band crack that caused separation of the coupling. The above failure resulted in loss of the tailpipe, smoke in the cockpit, in-flight fire and a very quick, direct in approach and landing on fire. There were no fatalities. Note again the safety wire is still in place.



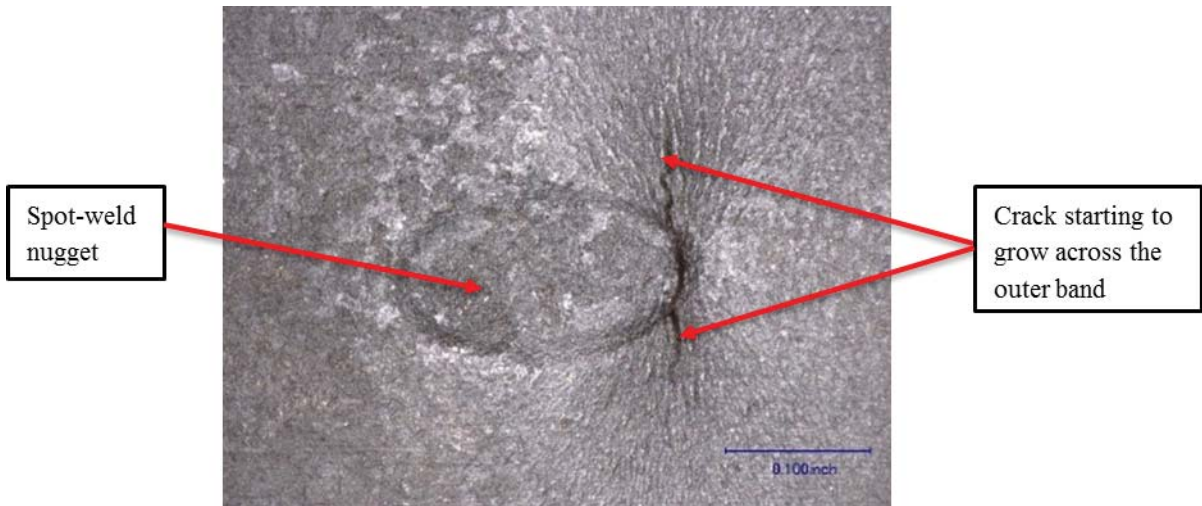
**Figure 21**  
**Spot-welded, Multi-segment Coupling**

The above crack originated at a spot-weld. However, the crack had not grown across the outer band and the coupling had not separated yet. Found on inspection for another issue.



**Figure 22**  
**Spot-welded, 3-segment Coupling**

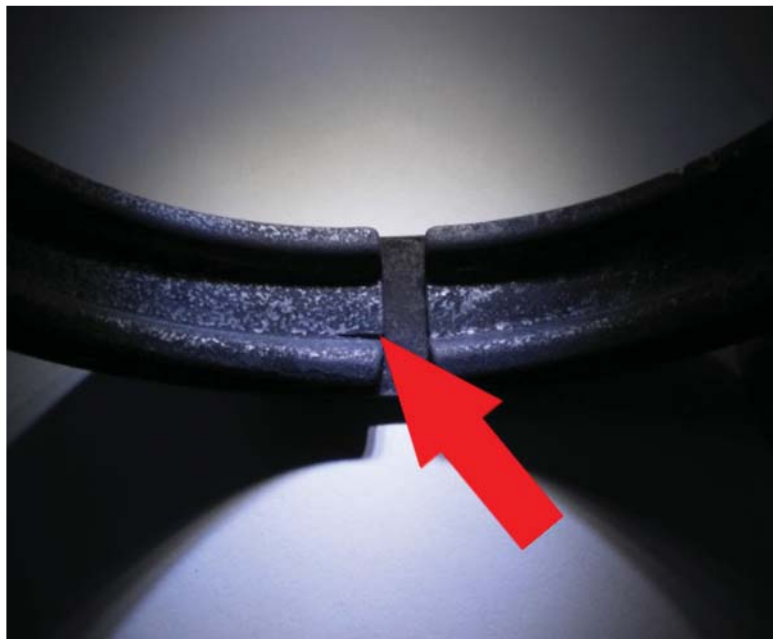
The red arrow shows where the coupling is deformed at a spot-weld where the crack originated. The crack had not yet grown across the outer band and the coupling had not separated. Found on inspection for another issue.



**Figure 23**  
**Same coupling above magnified**



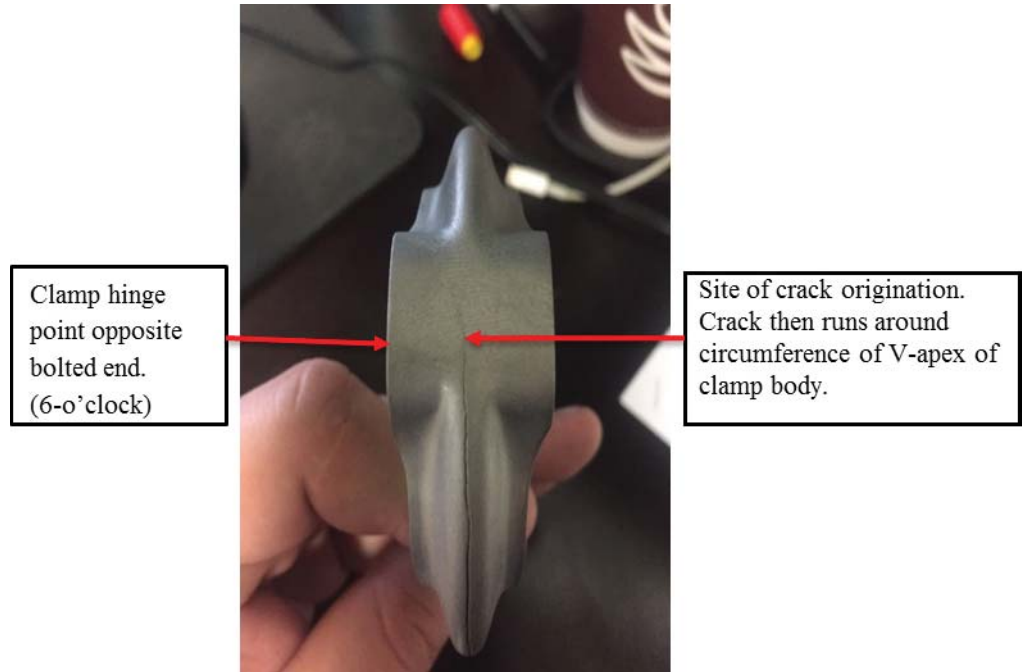
**Figure 24**  
**Spot-welded, 3-segment, Coupling**



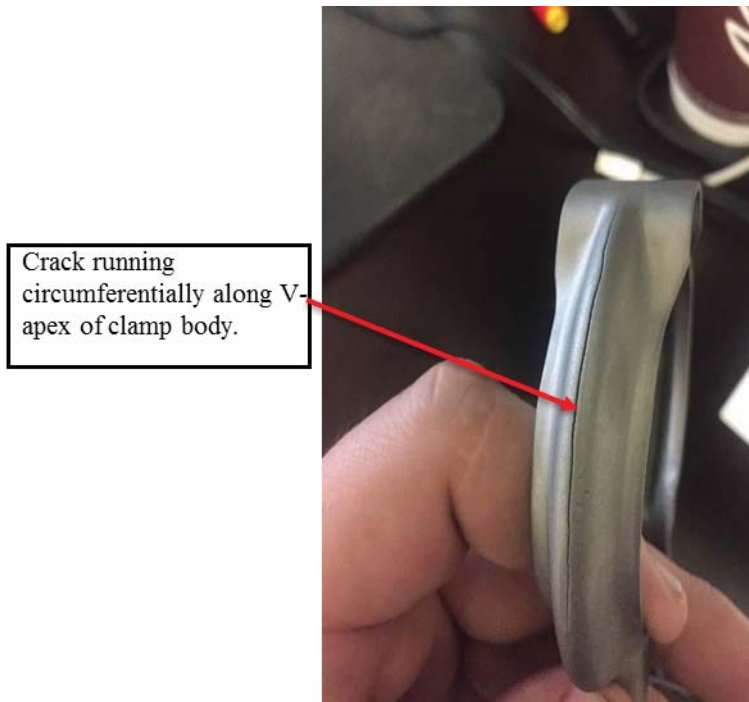
**Figure 25**  
**Same coupling above magnified**

Figure 25 is the same coupling as in Figure 24 above. This photograph was taken on a bench with a white top, using back lighting from a flashlight. There is a crack in the V-retainer segment inner corner radius. With the condition of the coupling, this crack was difficult to find with the coupling in-hand. This crack could not be found with the coupling installed. Found during inspection after tailpipe removal. Note the corrosion from salt-water operations.

## 7.2 Single-piece, Clamp Failures Encountered



**Figure 26**  
**Single-Piece Clamp**



**Figure 27**  
**Single-Piece Clamp**