

National Transportation Safety Board

Office of Aviation Safety

Washington, DC 20594



CEN23LA014

SYSTEMS

Group Chair's Factual Report

July 22, 2024

Attachment 2 - Aircraft Maintenance Manual Section 24-30
Battery Systems - Extract of ECU Back-up Batteries
Information and Procedures
(4 pages)

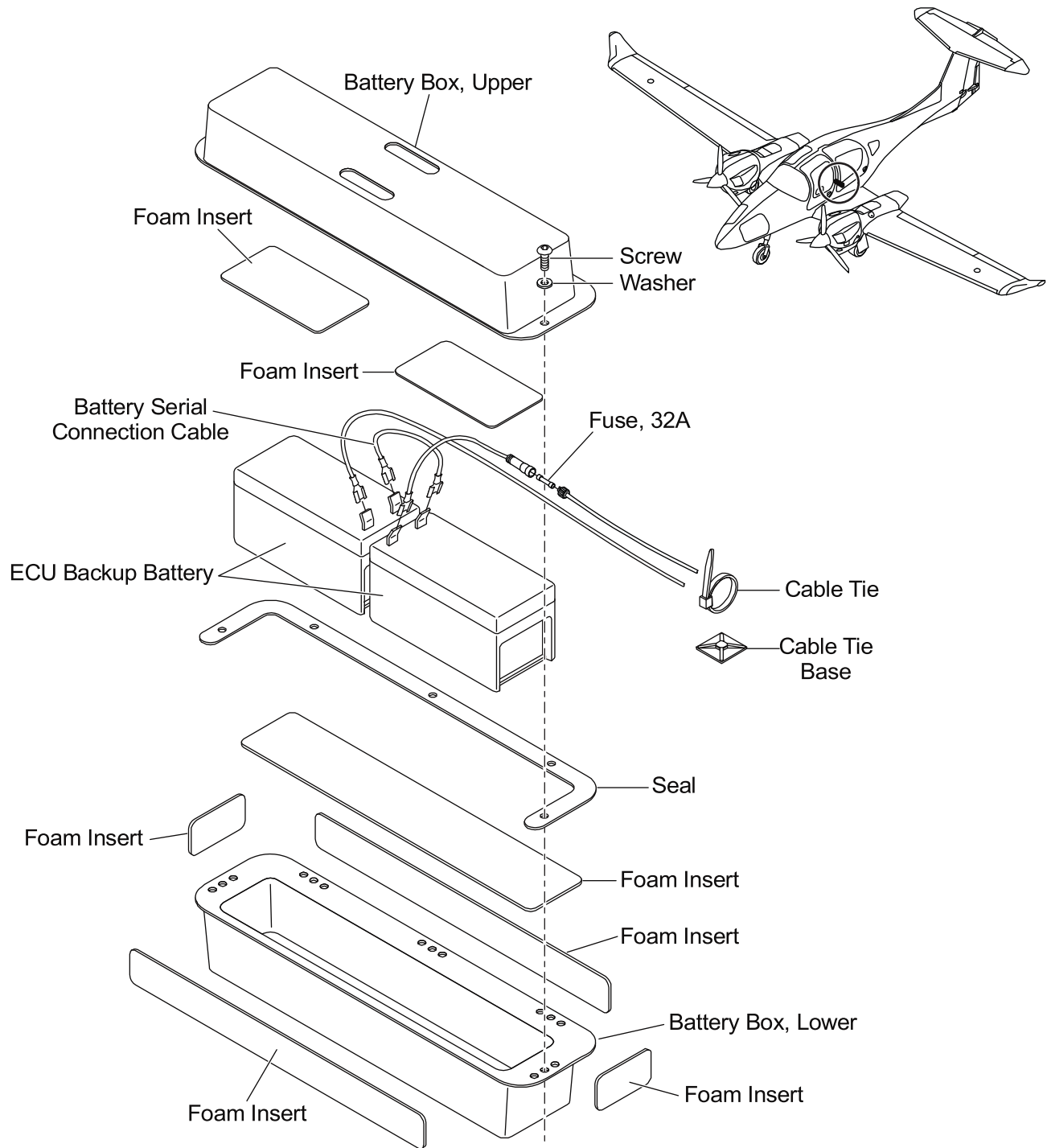

Figure 201 : ECU Backup Batteries Installation (LH)

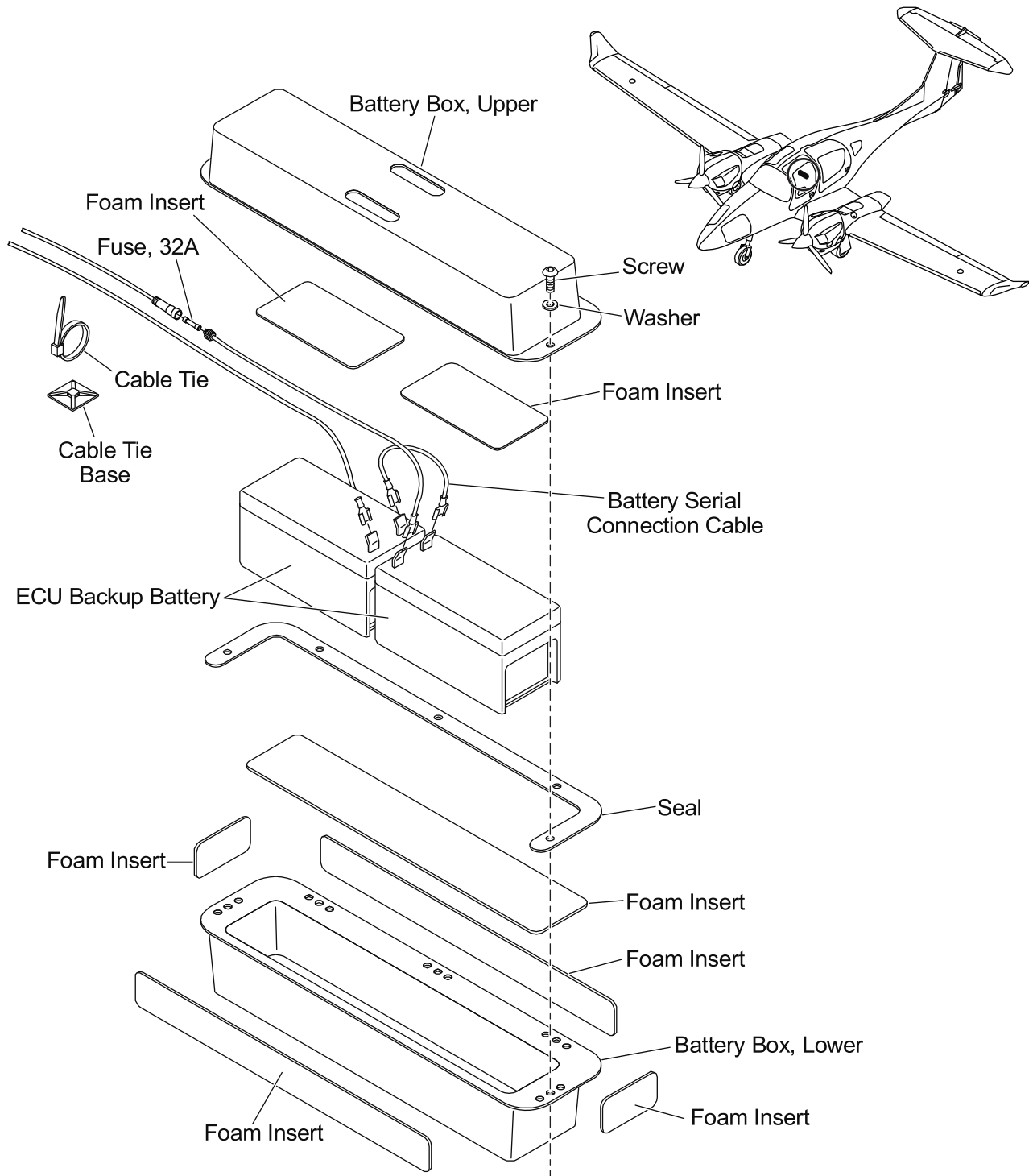

Figure 202 : ECU Backup Batteries Installation (RH)

4. **Remove/Install the ECU Backup Batteries**

Refer to Figures 201 and 202.

A. Remove the ECU Backup Batteries.

	Detail Steps/Work Items	Key Items/References
(1)	Remove the avionic bay cover.	
(2)	Disconnect the airplane main battery.	
(3)	Remove the ECU backup batteries: <ul style="list-style-type: none"> - Remove the passenger seats. - Disconnect the negative cable from the batteries that you will remove. - Disconnect the positive cable from the batteries that you will remove. - Disconnect the serial connection cable from the batteries that you will remove. - Release the battery pack hold cover. - Move the related batteries clear of the airplane. 	Refer to Section 25-10.

B. Install the ECU Backup Batteries.

	Detail Steps/Work Items	Key Items/References
(1)	Move the batteries into position in its mounts.	
(2)	Install the battery pack hold cover.	
(3)	Connect the related batteries: <ul style="list-style-type: none">- Connect the serial connection cable to the batteries that you will install.- Connect the positive cable to the batteries that you installed.- Connect the negative cable to the batteries that you installed.- Install the passenger seats.	Refer to Section 25-10.
(4)	Connect the airplane main battery.	Refer to Section 24-31.
(5)	Install the avionic bay cover.	
(6)	Do an engine ground run-up.	Make sure that the electrical system operates correctly.