

# TECHNICAL BULLETIN

## **Bell** Helicopter

A Textron Company

No. 407-07-78

Date SEP 19, 2007

Page 1 of 17

DATE
REV

**MODEL AFFECTED:** 407

**SUBJECT:** AFT FUSELAGE BULKHEAD 407-030-027-101  
AT FS 231.4, INTRODUCTION OF.

**HELICOPTERS AFFECTED:** Model 407 helicopters serial number 53000  
through 53714.

[Model 407 helicopters serial number 53715 through  
subsequent will have the intent of this bulletin  
accomplished prior to delivery]

**COMPLIANCE:** At Customer's Option

### **DESCRIPTION:**

Bell Helicopter recently introduced a new machined aft fuselage bulkhead. This improved bulkhead is made of aluminum with thicker material in bend radius for better fit and reliability. This bulkhead can be used on all 407 model helicopter as a spare replacement.

Part I of this bulletin provides instructions to remove the aft fuselage bulkhead. It gives the requirement and defines the limitations that will permit the use of a portable drill plate.

Part II of this bulletin provides instructions to install the new machined aft fuselage bulkhead using the existing pilot holes in the part. This is the preferred method and Part III is an alternate to this procedure.

Part III of this bulletin gives a procedure to install the new aft fuselage bulkhead when pilot holes in the new bulkhead do not match with the center of the bolt hole in the existing longeron/fitting. This is an alternate method to Part II.

### **APPROVAL:**

The engineering design aspects of this bulletin are Transport Canada approved.

**MANPOWER:**

Approximately 12.0 man-hours are required to complete this bulletin. Man-hours are based on hands-on time, and may vary with personnel and facilities available.

**WARRANTY:**

There is no special warranty credit applicable for parts or labor associated with this Bulletin.

**MATERIALS:**

**Required Material:**

The following material is required for the accomplishment of this bulletin and may be obtained through your Bell Helicopter Textron Supply Center.

<u>Part Number</u>	<u>Nomenclature</u>	<u>Quantity</u>
407-030-027-101	Bulkhead	1
100-145-6-6	Pin (Note 1)	2
30-277-6	Collar (Note1)	2
NAS1149F0316P	Washer (Note 1)	A/R
NAS1149F332P	Washer (Note 1)	A/R
NAS1149F363P	Washer (Note 1)	A/R
MS20426AD3	Rivet (Note 2)	14
MS20426AD4	Rivet (Note 2)	8
MS20426E4	Rivet (Note 2,3)	11
MS20470AD4	Rivet (Note 2)	9
MS20470AD5	Rivet (Note 2)	2
M7885/2-4	Rivet blind (Note 2)	11
M7885/4-5	Rivet blind (Note 2)	18
M7885/9-4	Rivet blind (Note 2,3)	A/R
MS21075L3	Nutplate (Note 4)	7
MS21061L3	Nutplate (Note 4)	A/R
NAS1785-3	Nutplate (Note 4)	A/R

**NOTES:**

1. Use appropriate washer thickness to suit grip of pin 100-145-6-6
2. Rivet length to be determined at installation
3. M7885/9-4 blind rivet can be used as an alternate

4. One MS21061L3 or NAS1785-3 can be used as alternate for MS21075L3 nutplate at one location only. Refer to Figure 1.
5. Aluminum material 2024T3 per QQ-A-250/4 or 6013T6 per AMS 4216, 12.5 X 1.3 inch is required to locally fabricate shim. Thickness will vary between 0.040 and 0.080 inch.

**Consumable Material:**

The following material is required to accomplish this bulletin, however this material is considered consumable (bench stock) material and may not require ordering depending on the operators consumable material stock levels. This material may be obtained through your Bell Helicopter Textron Supply Center.

<u>Part Number</u>	<u>Nomenclature</u>	<u>Quantity</u>	<u>Reference</u>
MIL-PRF-81733 2.5 OZ	Sealant	1	<a href="#">C-392</a> (Note 1)
Acetone gallon	Acetone (per Q-A-51)	1	<a href="#">C-316</a> (Note 2)
MIL-P-85582, TY1, CL2	Primer	1	<a href="#">C-204</a> (Note 3)
MIL-C-81706 1 QT	Chem Film, alodine 1200	1	<a href="#">C-100</a>

**NOTES:**

- 1) As an alternate, use MIL-S-81733.
- 2) As an alternate, use Methyl Ethyl Ketone ([C-309](#)).
- 3) As an alternate, use MIL-P-23377.

**SPECIAL TOOLS:**

Aft fuselage/tailboom portable drill plate (locally manufactured). Refer to Figure 3.  
Flange bushings and drill bushings. Refer to figure 2 for size required.

**WEIGHT AND BALANCE:**

Not affected

**ELECTRICAL LOAD DATA:**

Not affected

**REFERENCES:**

Illustrated Parts Breakdown ([BHT-407-IPB](#))  
Maintenance Manual ([BHT-407-MM](#))

Structural Repair Manual ([BHT-206-SRM-1](#))

Standard Practice Manual ([BHT-ALL-SPM](#))

**PUBLICATIONS AFFECTED:**

Structural Repair Manual ([BHT-206-SRM-1](#))

**ACCOMPLISHMENT INSTRUCTIONS:**

**Part I: Removal of aft fuselage bulkhead and verification of longeron/fittings**

1. At FS 231.4, remove the aft bulkhead (5) from the fuselage as follows:
  - a) Refer Figure 1, View A. Drill and remove 9 rivets (14), 2 rivets (13) and 2 rivets (12) securing upper skin (10), and both upper longeron/fittings.
  - b) Remove 2 Hi-lok pins (16) securing both lower longeron/fittings.
  - c) Drill and remove 16 rivets (15) securing L/H aft skin (11).
  - d) Drill and remove 11 rivets (17) securing lower fairing (9).
  - e) Drill and remove 11 rivets (19)securing web (8).
  - f) Drill and remove 1 rivet (22) securing R/H angle support (4).
  - g) Drill and remove 8 rivets (18) securing clips (1)(2)(3) and angle support (4) to aft face of bulkhead (5).

**-NOTE-**

Solid shims may have been installed around circumference of bulkhead (5) to fill existing gap. Retain these shims for reinstallation.

- h) Separate bulkhead (5) from aft fuselage structure using a warm thin blade putty knife to release sealant. Remove and discard bulkhead (5) with shims (6).
2. Locally manufacture a drill plate to dimension shown in Figure 3.

**CAUTION**

WHEN THE AFT FUSELAGE BULKHEAD IS REMOVED, IT IS POSSIBLE THAT THE UPPER RIGHT LONGERON SLIGHTLY MOVES OUTBOARD. THIS CONDITION WILL REQUIRE APPLYING PRESSURE ON THE UPPER RIGHT LONGERON ASSEMBLY TO ALIGN THE FITTING BOLT HOLE WITH THE DRILL PLATE HOLE.

3. Verify that the fuselage to tailboom attachment bolt pattern match with the drill plate.

**-NOTE-**

Maximum diameter allowed in service on upper longeron bolt hole is 0.453 inch. Maximum diameter allowed in service on lower longeron bolt hole is 0.391 inch.

- a) If bolt hole pattern match the drill plate and each hole does not exceed maximum diameter, proceed to step 4.
  - b) If any bolt hole does not match, the affected longeron must be replaced. The helicopter must be installed in a BHT approved fuselage fixture to perform this task.
4. Verify that the four longeron/fittings are in plane within 0.002 inch.
    - a) Attach drill plate to the four longeron/fittings using existing hardware and torque nuts to 50 in-lbs. A gap in excess of 0.002 inch between drill plate and aft face of longeron/fitting indicates that this longeron/fitting is not in plane.
    - b) If longeron/fittings are in plane, proceed with Part II or Part III.
    - c) If one longeron/fitting is not in plane, the affected longeron/fitting must be replaced using the drill plate prior to install the aft bulkhead.
    - d) If more than one longeron/fitting is not in plane, the affected longeron/fitting must be replaced. The helicopter must be installed in a BHT approved fuselage fixture to perform this task.

**Part II: Installation of a new machined aft fuselage bulkhead (preferred method)**

**-NOTE-**

This procedure uses the existing 3/16 pilot holes in the new machined frame. Part III is an alternate to this procedure

when pilot hole does not match with the center of hole in longeron/fitting and drill plate.

**-NOTE-**

Four spacers of equivalent thickness (+/-0.001 inch) may be required between each tailboom attachment fitting and the drill plate to prevent interference with the aft fuselage skins.

1. Refer to Figure 2. Install new aft bulkhead (5) into position. Refer to View A, attach drill plate (1) using bushings (12) (13) (14) to aft fuselage at upper left and right fittings (6). Refer to View B, attach drill plate (1) using bushings (2) (3) (10) at lower left and right fittings (9) Torque all bolts (7) and nuts (8) to 50 in-lbs.
2. Refer to Figure 1. Measure gap between L/H aft skin (11) and bulkhead (5). Record value.
3. Fabricate shim (7) from 2024T3 or 6013T4 aluminum material to dimension shown in Figure 1 and thickness to the value recorded in step 2. Maximum shim thickness not to exceed 0.080 inch. Taper as required to a minimum of 0.005 inch.
4. Position shim on L/H of bulkhead and trim as required to obtain a gap of 0.030 to 0.060 inch at each extremity.

**-NOTE-**

Do not install shims between aft face of longeron/fitting and bulkhead.

5. Verify there is no gap at any other location between the side flange of bulkhead and skins or longerons.
  - a. If gap exists, fabricate shim using Aluminum 2024T3 material to fill gap and tapering as required to minimum 0.005 inch. Maximum thickness of shim not to exceed 0.032 inch thick at any location.
  - b. Reinstall solid shims that were retained in Part I step 1 if same gap condition exists.
6. Do not drill holes for nutplates (22) and holes for rivets (19) at this time. Transfer all rivet holes from the aft fuselage to the bulkhead (5) and install clecos.

7. Refer to Figure 2, remove bolt (7), nut (8), bushings (3 and 10) from the lower R/H fitting (9). Drill by increasing size of drill bit until you can final ream bulkhead (5) to 0.376-0.378 inch. Install a 3/8 bolt size and nut, and torque to 50 in-lbs.
8. Repeat step 7 for lower L/H longeron/fitting.
9. Remove bolt (7), nut (8), bushings (13 and 14) from the upper L/H fitting (6). Drill by increasing size of drill bit until you can final ream bulkhead (5) to 0.4385-0.4405. Install a 7/16 bolt size and nut, and torque to 50 in-lbs.
10. Repeat step 9 for upper R/H longeron/fitting.
11. Temporarily install access door with screws on R/H of fuselage. Locate 7 holes from door for the nutplates (20). Drill 7 holes size 0.190 to 0.196 inch. Remove access door.
12. Remove drill plate and clecos. Remove aft bulkhead (5) and shim (7).
13. Fabricate a template using the old bulkhead by removing the side flange from the old bulkhead. Position template over the new bulkhead (5) using longeron bolt holes as locator. Transfer the 11 rivets holes (19) in new bulkhead. Remove template.
14. Deburr all holes and clean with acetone (C-316). Apply chemical film (C-100) and primer (C-204) to all bare metal surfaces.
15. Install the 7 nutplates (20) with rivets (21) on right flange of bulkhead (5).
16. Apply sealant (C-392) to faying surface of shim (7). Install shim (7) with new bulkhead (5) into position on aft fuselage with clecos.
17. Secure bulkhead to longeron fitting with drill plate as shown in View D.
18. Refer to Figure 1, secure aft bulkhead (5) with rivets as shown in View A.
19. Remove drill plate from aft fuselage. Clean with acetone (C-316). Apply chemical film (C-100) and primer (C-204) to all bare metal surfaces.
20. Apply sealant (C-392) at each edge of skins.
21. Refinish paint as required.
22. Annotate aircraft technical records to indicate compliance with this Technical Bulletin.

**Part III: Installation of a new machined aft fuselage bulkhead (alternate method)**

**-NOTE-**

This procedure does not use the existing 3/16 pilot holes in the new machined frame.

**-NOTE-**

Four spacers of equivalent thickness (+/- 0.001 inch) may be required between each tailboom attachment fitting and the drill plate to prevent interference with the fuselage skins.

1. Refer to Figure 1. Install new aft fuselage bulkhead (5) into position.
2. Measure gap between L/H aft skin (11) and bulkhead (5). Record value.
3. Fabricate shim (7) from 2024T3 or 6013T4 aluminum material to dimension shown in Figure 1 and thickness to the value recorded in step 2. Maximum shim thickness not to exceed 0.080 inch. Taper as required to a minimum of 0.005 inch.
4. position shim on L/H of bulkhead and trim as required to obtain a gap of 0.030 to 0.060 inch at each extremity

**CAUTION**

**DO NOT DAMAGE BULKHEAD OR LONGERON/FITTING. USE PROTECTIVE MATERIAL WHEN SECURING WITH C-CLAMP.**

5. Temporarily secure bulkhead (5) to each longeron/fitting with C-clamp.
6. Refer to Figure 2, View B. Install flange bushing (10) in both lower longeron/fitting. Backdrill size 0.187/0.189 inch from longeron into the bulkhead (5). Those holes are the new pilot holes.
7. Remove the bulkhead (5) from fuselage. On a bench, install bushings (2) and (3) in drill plate for the lower longeron/fitting holes. Attach bulkhead to drill plate using new pilot holes drilled in step 6 with 3/16 bolt and nut. Torque to 50 in-lb. Secure bulkhead to drill plate with C-clamp all around circumference.



8. Remove 3/16 bolt thru lower R/H longeron/fitting hole and drill by increasing size of drill bit until you can final ream bulkhead (5) to 0.376-0.378 inch. Install a 3/8 bolt size and nut, and tight to 50 in-lbs.
9. Repeat Step 8 for lower L/H longeron/fitting.
10. Drill both upper longeron/fitting holes by increasing size of drill bit until you can final ream bulkhead (5) to 0.4385-0.4405 inch.
11. Separate bulkhead from drill plate. Deburr holes and clean with acetone (C-316). Apply chemical film (C-100) and primer (C-204) to all bare metal surfaces.
12. Refer to Figure 2, View D. Position bulkhead on aft fuselage. Install drill plate with full size nut, bolt and washer (15).

-NOTE-

Do not install shims between aft face of longeron/fitting and bulkhead.

13. Verify there is no gap at any other location between the side flange of aft bulkhead and skins or longerons.
  - a. If gap exists, fabricate shim using Aluminum 2024T3 material to fill gap and tapering as required to minimum 0.005 inch. Maximum thickness of shim not to exceed 0.032 inch thick at any location.
  - b. Reinstall solid shims that were retained in Part I step 1 if same gap condition exists.
14. Refer to Figure 1. Do not drill holes for nutplates (22) and holes for rivet (19) at this time. Transfer all rivet holes from the aft fuselage to the bulkhead (5) and install clecos.
15. Temporarily install access door with screws on R/H of fuselage. Locate 7 holes from door for the nutplates (20). Drill 7 holes size 0.190 to 0.196 inch. Remove access door.
16. Remove drill plate and clecos. Remove aft bulkhead (5) and shim (7).
17. Fabricate a template using the old bulkhead by removing the side flange from the old bulkhead. Position template over the new bulkhead (5) using longeron bolt holes as locator. Transfer the 11 rivets holes (19) in new bulkhead. Remove template.

18. Deburr all holes, clean with acetone (C-316). Apply chemical film (C-100) and primer (C-204) to all bare metal surfaces.
19. Install the 7 nutplates (20) with rivets (21) on right flange of bulkhead (5).
20. Apply sealant (C-392) to faying surface of shim (7), bulkhead (5) and L/H skin (11). Install shim (7) with new bulkhead (5) into position on aft fuselage with clecos.
21. Secure bulkhead to longeron fitting with drill plate as shown in View D.
22. Refer to Figure 1, secure aft bulkhead (5) with rivets as shown in View A.
23. Remove drill plate from aft fuselage. Clean with acetone (C-316). Apply chemical film (C-100) and primer (C-204) to all bare metal surfaces.
24. Apply sealant (C-392) at each edge of skins.
25. Refinish paint as required.
26. Annotate aircraft technical records to indicate compliance with this Technical Bulletin.

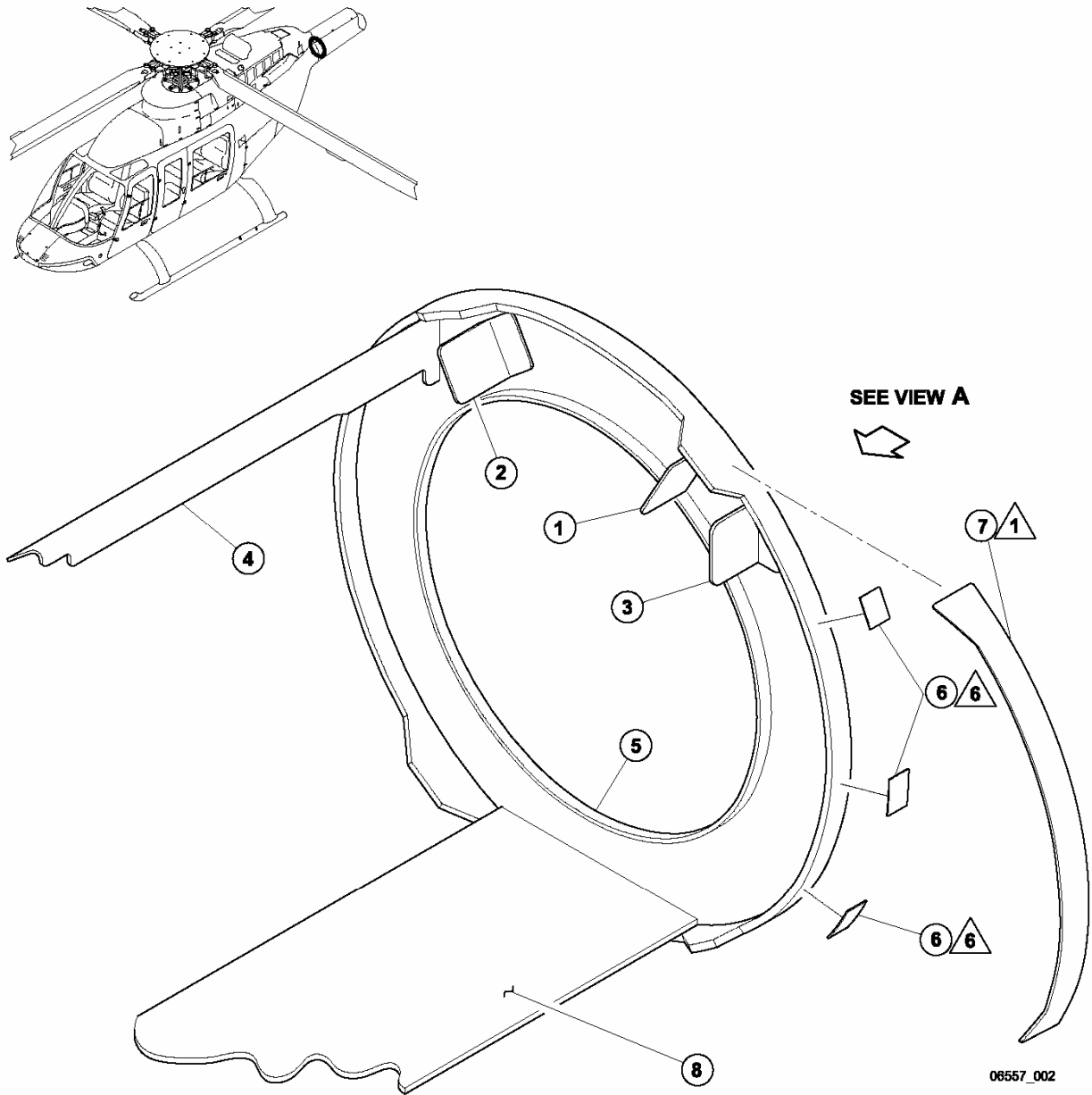

Figure 1. Installation of aft fuselage bulkhead (sheet 1 of 4)

06557\_002

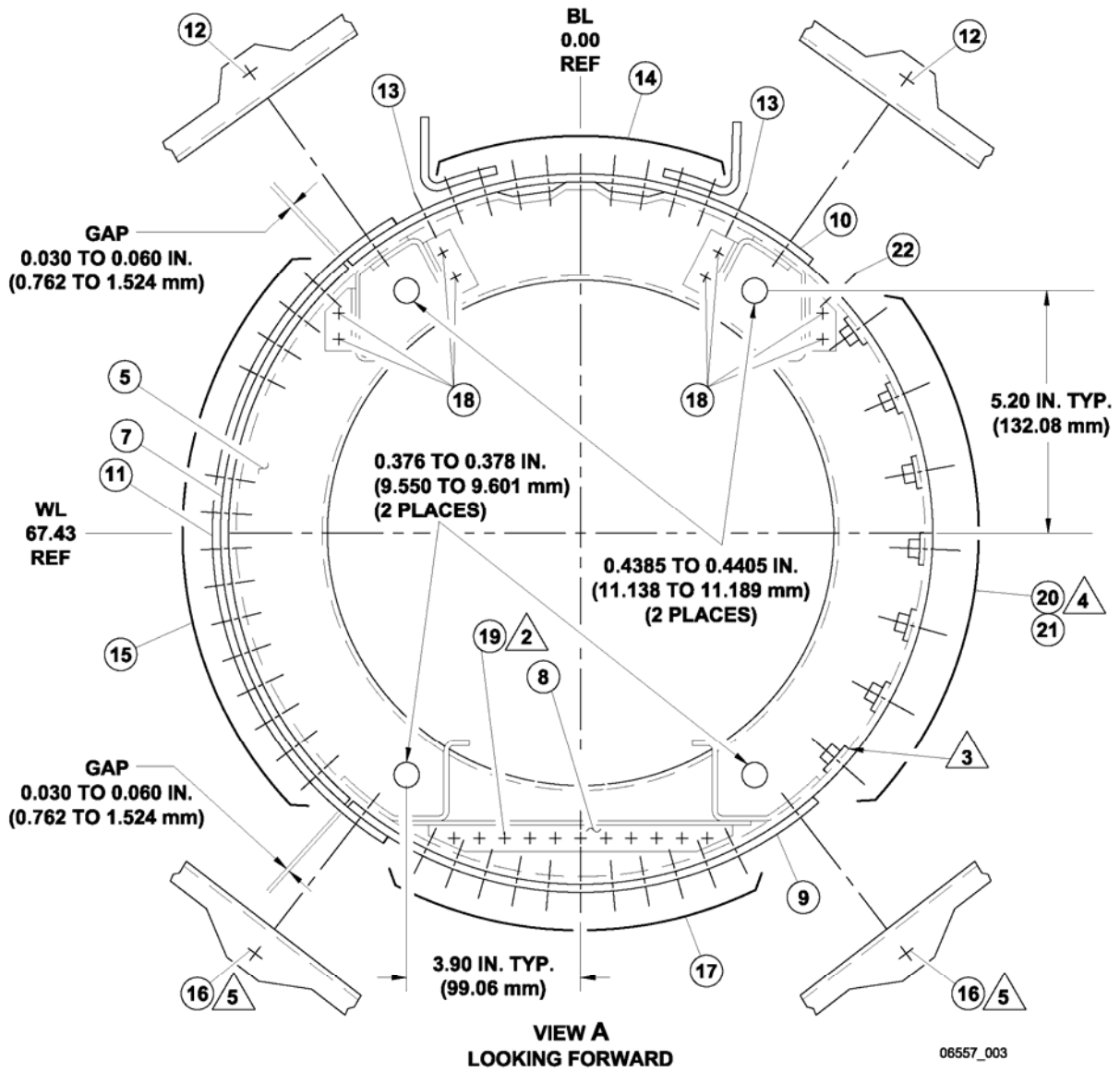

Figure 1. Installation of aft fuselage bulkhead (sheet 2 of 4)

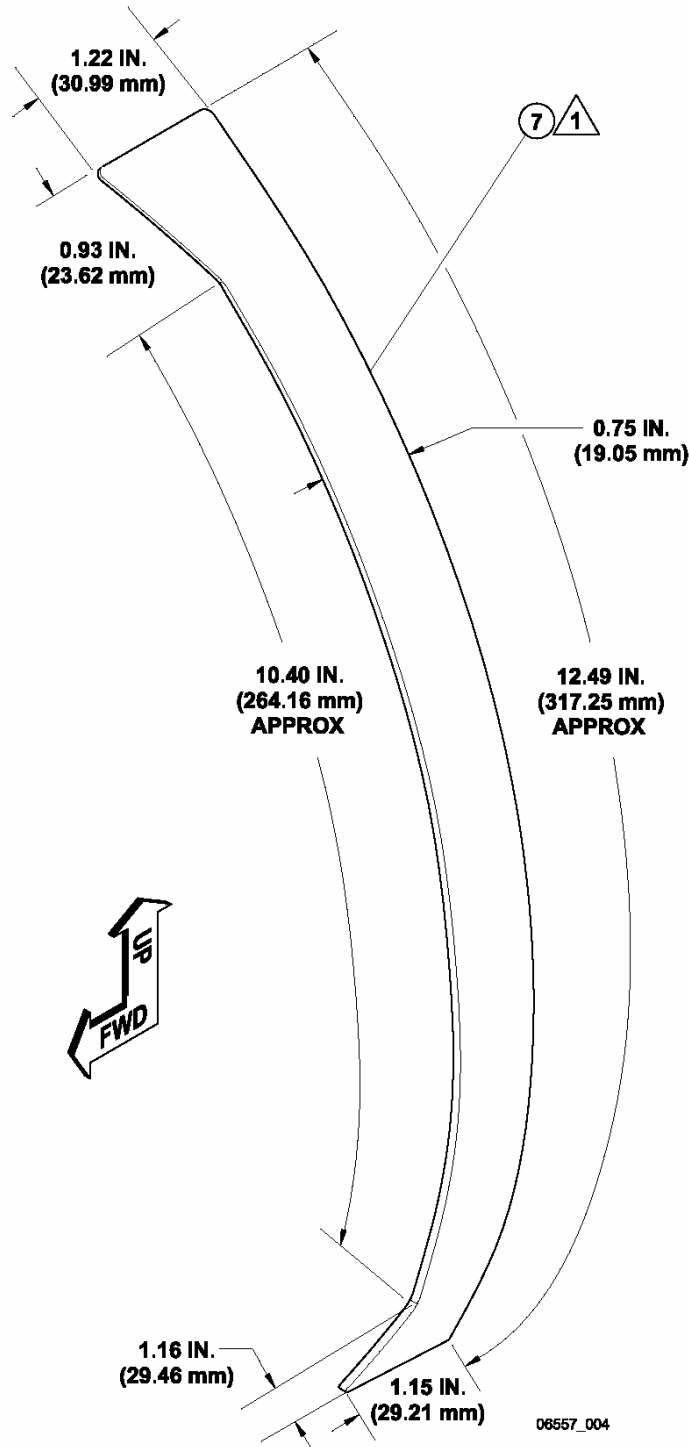

Figure 1. Installation of aft fuselage bulkhead (sheet 3 of 4)

1. Clip L/H Inboard (ref)
2. Clip R/H inboard (ref)
3. Clip L/H outboard (ref)
4. Angle support (ref)
5. Frame 407-030-027-101
6. Shim (ref)
7. Shim
8. Web
9. Lower fairing
10. Top skin
11. L/H skin
12. Rivet M7885/4-5
13. Rivet MS20470AD5
14. Rivet MS20470AD4
15. Rivet M7885/4-5
16. Pin 100-145-6-6  
Collar 30-277-6  
Washer NAS1149F0316P  
Washer NAS1149F0332P  
Washer NAS1149F0363P
17. Rivet M7885/2-4
18. Rivet MS20426AD4
19. Rivet MS20426E4
20. Nutplate MS21075L3
21. Rivet MS20426AD3
22. Rivet MS20426AD4

5

#### NOTES

1. Fill gap between L/H skin and frame with shim manufactured from 2024T3 or 6013T4 aluminum material. Maximum shim thickness not to exceed 0.080 inches thick (2.032 mm). Trim as required to match contour of frame and obtain 0.030 to 0.060 inch gap (0.762 to 1.524 mm) at each end. Taper shim as required to a minimum of 0.005 inches and install in sealant (C-392).
2. As an alternate, blind rivet M7885/9-4 can be installed in lieu of MS20426E4.
3. MS21061L3 or NAS1789-3 nutplates may be used as alternate for MS21075L3 at this location only.
4. Hole size for nutplate is 0.190 to 0.196 (4.8 to 5.0 mm) in frame to match access door.
5. Use appropriate washer thickness to suit grip of pin.
6. Remove and discard existing shims.

08557\_005

Figure 1. Installation of aft fuselage bulkhead (sheet 4 of 4)

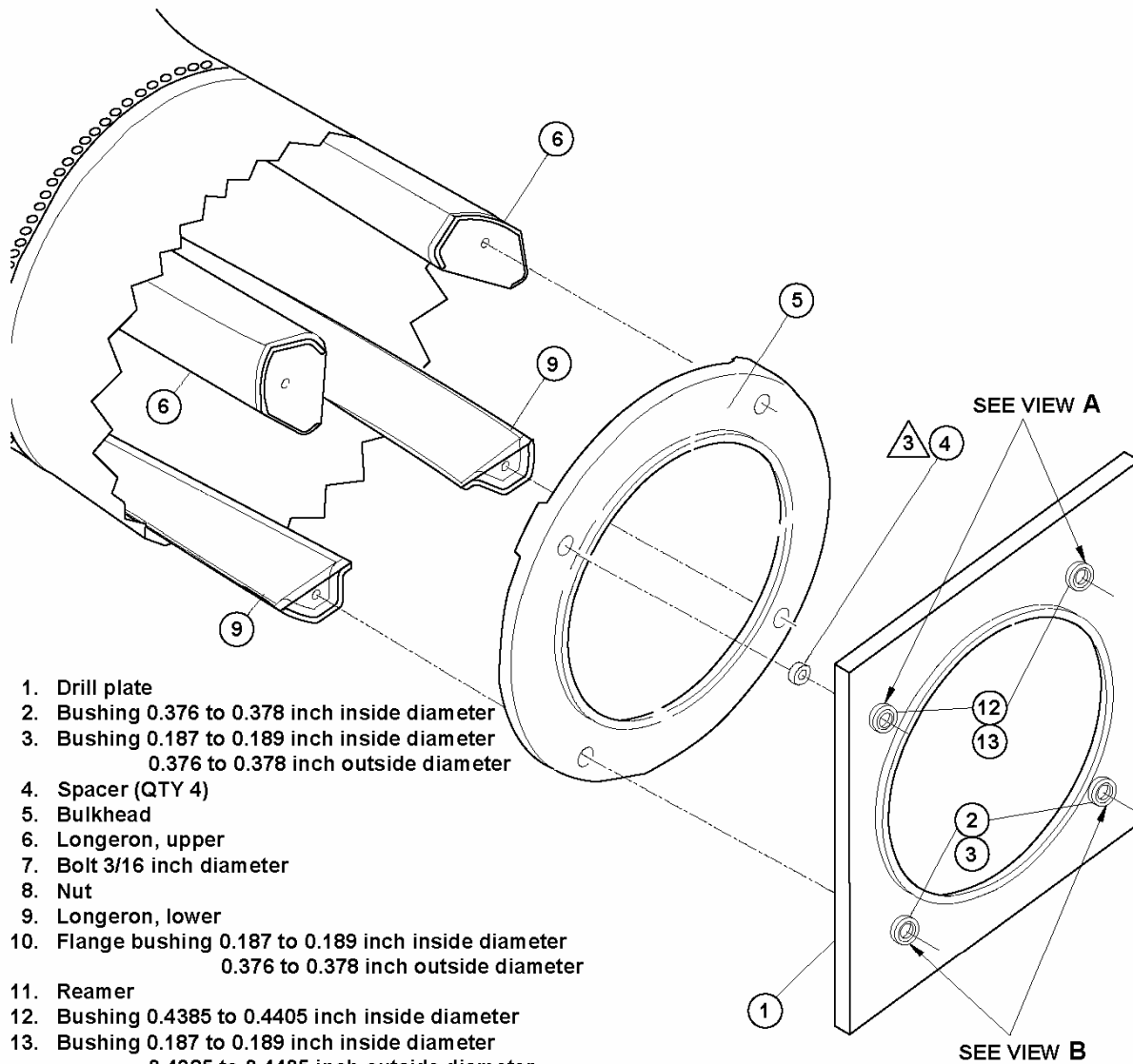

1. Drill plate
2. Bushing 0.376 to 0.378 inch inside diameter
3. Bushing 0.187 to 0.189 inch inside diameter  
0.376 to 0.378 inch outside diameter
4. Spacer (QTY 4)
5. Bulkhead
6. Longeron, upper
7. Bolt 3/16 inch diameter
8. Nut
9. Longeron, lower
10. Flange bushing 0.187 to 0.189 inch inside diameter  
0.376 to 0.378 inch outside diameter
11. Reamer
12. Bushing 0.4385 to 0.4405 inch inside diameter
13. Bushing 0.187 to 0.189 inch inside diameter  
0.4385 to 0.4405 inch outside diameter
14. Flange bushing 0.187 to 0.189 inch inside diameter  
0.4385 to 0.4405 inch outside diameter
15. Bolt, nut, and washer, full size
16. Washer

**NOTES**

- 1 Torque 50 inch-pounds at four locations.
- 2 Verify that there is no gap between longeron and bulkhead.
- 3 A quantity of four spacers of the same thickness within 0.001 inch must be used to clear interference between drill plate and aft fuselage skin.

06557\_006

**Figure 2. Installation of portable drill plate (sheet 1 of 2)**

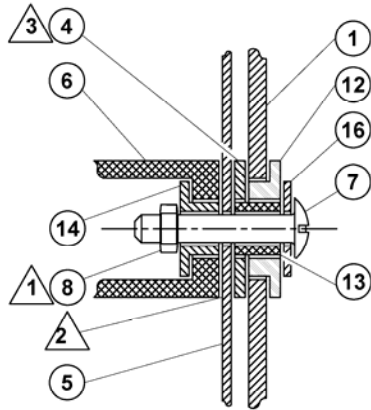

**VIEW A - UPPER LONGERON**  
TYPICAL INSTALLATION FOR UPPER LONGERON. FULL SIZE HOLE IN LONGERON AND PILOT HOLE OF 3/16" IN BULKHEAD.

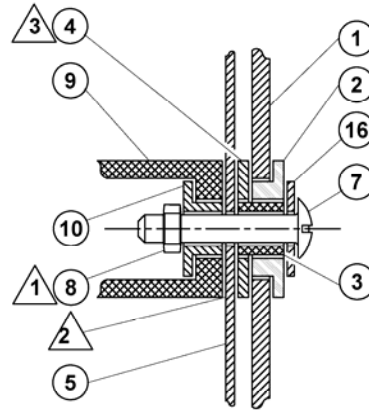

**VIEW B - LOWER LONGERON**  
TYPICAL INSTALLATION FOR LOWER LONGERON. FULL SIZE HOLE IN LONGERON AND PILOT HOLE OF 3/16" IN BULKHEAD.

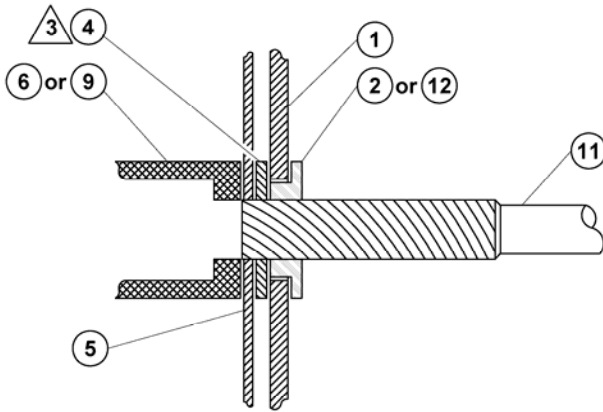

**VIEW C**  
TYPICAL INSTALLATION TO DRILL FULL SIZE THROUGH BULKHEAD

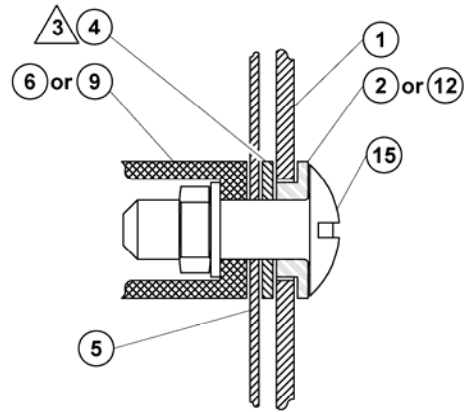

**VIEW D**  
TYPICAL INSTALLATION OF FULL SIZE HOLE IN BULKHEAD AND LONGERON FITTING

06557\_007

**Figure 2. Installation of portable drill plate (sheet 2 of 2)**



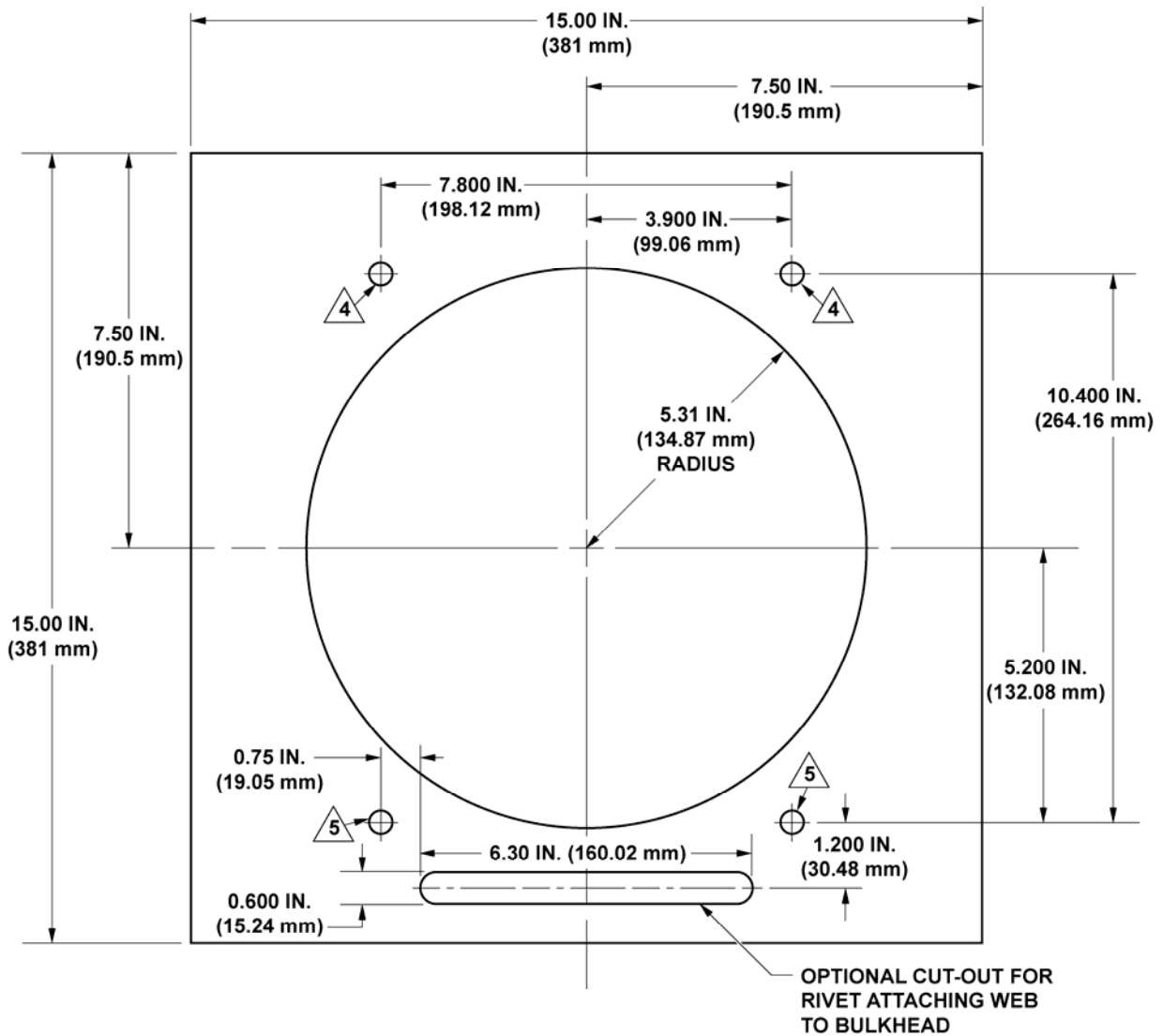

**NOTES**

1. Make from 0.50 Aluminum plate-surface flat within  $\pm 0.001$  inch (0.0254 mm).
2. Install drill bushings in four holes for extended plate life.
3. Tolerance (in inches) .XXX =  $\pm 0.003$ , .XX =  $\pm 0.01$ , except as noted.
- 4 Drill and ream perpendicular to surface 0.4385 to 0.4405 inch (11.138 to 11.189 mm).
- 5 Drill and ream perpendicular to surface 0.3760 to 0.3780 inch (9.550 to 9.601 mm).

06557\_008

**Figure 3. Fabrication of aft fuselage/tailboom portable drill plate**