



SURVIVAL FACTORS ATTACHMENT

Alabama Uniform Traffic Crash Report 1681937

Greenville, AL

HWY21MH009

(12 pages)

ALABAMA UNIFORM TRAFFIC CRASH REPORT

Crash Report Case No. 1681937

Check if Amendment

Check if Error Correction

# Vehicles	# Pedestrians	# Injured	# Fatalities	# Unit 1 Type	Unit 2 Type
4	0	1	8	11	27

Local Case No. MAIT38-21-129

Sheet 1

LOCATION AND TIME

Date: 06/19/2021
Time: 1420 MT
Day of Week: Sat
County: Butler
City: Rural Butler
Rural:
Local Zone: N/A

Hwy Class: 1
On Street, Road, Highway: I-65
At Intersection of or Between (Node 1): Fort Deposit Road
And (Node 2): Crossover

(On) Street/Road/Hwy Code: I065
7640
Node Code: 1 2
7644
From Node 1: 1.64 Miles

Mile Post: 138.3
Control Access Hwy Loc: 1
Primary Contrib Circums: 7
Primary Contributing Unit #: 1
First Harmful Event Location: 32
First Harmful Event Location: 4
Most Harmful Event: 13

Distance to Fixed Object: 3 feet
Roadway Junction/Feature: 2
Manner of Crash: 7
Lat Coordinate: 31° 56' 43.545" N
Long Coordinate: 86° 33' 31.946" W
Coordinate Type: 1
Hwy Side: 1

School Bus Related: 1
Crash Severity: K
Distracted Driving: 97

DRIVER

1 UNIT NO

Driver Full Name: Mamuye Ayane Takelu
City and State: Clarkston GA
ZIP: 30021

DOB: [Redacted]
Race: 2, Sex: 1, DL State: GA
Driver License No.: [Redacted]
DL Class: A, DL Status: C
Restrict Violations: 97, CDL Status: C, Endorse Violations: 97

Place of Employment: A Smat Express LLC (Clarkston, GA)
Residence Less Than 25 Miles: No

Liability Insurance Co.: Ace American Insurance Company
Liability Policy No.: [Redacted]
Insurance NAIC Number: Unk

Driver Condition: 1
Sobriety/Officer Opinion: No
Alcohol: No, Type Alcohol Test Given: 1
Alcohol Test Results: Unk, Type Drug Test Given: 1
Drug Test Results: 99, Maneuver: 1

Most Harmful Event for MV: 13
Travel Road Name: I-65
Road Code: I065, Travel Direction: 1
Unit Contributing Circumstance: 7, Total Injuries in Unit: 0

Sequence of Events:
Event 1: 6, Event 2: 32, Event 3: 22, Event 4: 13
First Harmful Event Location: 1

Veh Year: 2005, Make: FRHT, Veh Model: Conventional S, Body: 97, V.I.N.: 1FUJBBCG25LN [Redacted]

Owner's Name: Same, License Tag Number: [Redacted], State: GA, Year: 2021

Street or R.F.D.: Same, City: [Redacted], State: GA, Zip: [Redacted]

Type: 11, Usage: 6, Emergency Status: 97, Placard Status: 3, Placard Required: 2, Hazardous Cargo: 1, Hazardous Cargo Released?: 97

Attachment: 4, Oversized Load: No, If Yes, Did Owner Have Permit?: N/A, Contrib Defect: 1, Speed Limit: 70 MPH, Est Speed: 70 MPH, Citation Offense(s) Charged: None

Damage Severity: 4, Towed?: 1, Vehicle Towed By Whom: Till's Towing (ROT)
Towed To Where: Till's Towing (Greenville, AL)

Areas Damaged Are Shaded:
14 Under Carriage
11, 10, 9, 8, 7, 6
1, 2, 3, 4, 5
12, 13, 15, 16, 97, N/A
Point of Initial Impact: 12

VEHICLE or NON-MOTORIST: VEHICLE

DRIVER

2 UNIT NO

Driver Full Name: CANDICE LUZ GULLEY
City and State: CAMP HILL AL
ZIP: 36850, Telephone: [Redacted]

DOB: [Redacted]
Race: 1, Sex: 2, DL State: AL
Driver License No.: 6630297
DL Class: D, DL Status: C
Restrict Violations: 97, CDL Status: 97, Endorse Violations: 97

Place of Employment: Tallapoosa County Girls Ranch (Camp Hill, AL)
Residence Less Than 25 Miles: No

Liability Insurance Co.: AmGuard Insurance Company
Liability Policy No.: [Redacted]
Insurance NAIC Number: Unk

Driver Condition: 1
Sobriety/Officer Opinion: No
Alcohol: No, Type Alcohol Test Given: 1
Alcohol Test Results: Unk, Type Drug Test Given: 1
Drug Test Results: 99, Maneuver: 98

Most Harmful Event for MV: 13
Travel Road Name: I-65
Road Code: I065, Travel Direction: 1
Unit Contributing Circumstance: 97, Total Injuries in Unit: 9

Sequence of Events:
Event 1: 23, Event 2: 23, Event 3: 13, Event 4: 97
First Harmful Event Location: 1

Veh Year: 2017, Make: FORD, Veh Model: TRANSIT-350 WAGON T-, Body: 97, V.I.N.: 1FBZX2YM2HKE [Redacted]

Owner's Name: Tallapoosa County Girls Ranch, License Tag Number: [Redacted], State: AL, Year: 2021

Street or R.F.D.: 174 SAMFORD DR, City: CAMP HILL, State: AL, Zip: 36850

Type: 27, Usage: 30, Emergency Status: 97, Placard Status: 3, Placard Required: 97, Hazardous Cargo: 97, Hazardous Cargo Released?: 97

Attachment: 1, Oversized Load: N/A, If Yes, Did Owner Have Permit?: N/A, Contrib Defect: 1, Speed Limit: 70 MPH, Est Speed: 000 MPH, Citation Offense(s) Charged: None

Damage Severity: 4, Towed?: 1, Vehicle Towed By Whom: Till's Towing (ROT/THI)
Towed To Where: Till's Towing

Areas Damaged Are Shaded:
14 Under Carriage
11, 10, 9, 8, 7, 6
1, 2, 3, 4, 5
12, 13, 15, 16, 97, N/A
Point of Initial Impact: 12

VEHICLE or NON-MOTORIST: VEHICLE

3 UNIT NO LEFT SCENE COM VEH VEHICLE or NON-MOTORIST	Driver Full Name Michael G Pruitt II		Street Address [REDACTED]				City and State Mt. Juliet TN			ZIP 37122	Telephone [REDACTED]
	DOB Month Day Year [REDACTED]	Race 1	Sex 1	DL State TN	Driver License No. [REDACTED]	DL Class A	DL Status C	Restrict Violations 97	CDL Status 97	Endorse Violations C	97
	Place of Employment Masters Landscape Design (Mt. Juliet, TN)								Residence Less Than 25 Miles No		
	Liability Insurance Co. Selective Insurance Company					Liability Policy No. [REDACTED]			Insurance NAIC Number Unk		
	Driver Condition 1	Sobriety/ Officer Opinion 1	Alcohol: No Drugs: No	Type Alcohol Test Given 1	Alcohol Test Results Unk	Type Drug Test Given 1	Drug Test Results 99	Maneuver 98			
	Most Harmful Event for MV 13	Travel Road Name I-65			Road Code I065	Travel Direction 1	Unit Contributing Circumstance 97	Total Injuries in Unit 0			
	Sequence of Events 23	Event 1 13	Event 2 13	Event 3 97	Event 4 97	First Harmful Event Location 3			Areas Damaged Are Shaded		
	Veh Year 2019	Make FORD	Veh Model F-150 King Ranch	Body 2	V.I.N. 1FTEW1E53KFC [REDACTED]						
	Owner's Name Same				License Tag Number [REDACTED]	State TN	Year 2021				
	Street or R.F.D. Same				City [REDACTED]	State TN	Zip [REDACTED]				

4 UNIT NO LEFT SCENE COM VEH VEHICLE or NON-MOTORIST	Driver Full Name JAMES EARL MAYS		Street Address [REDACTED]				City and State VERBENA AL			ZIP 36091	Telephone [REDACTED]
	DOB Month Day Year [REDACTED]	Race 2	Sex 1	DL State AL	Driver License No. [REDACTED]	DL Class DM	DL Status C	Restrict Violations 97	CDL Status 97	Endorse Violations 97	97
	Place of Employment Retired								Residence Less Than 25 Miles No		
	Liability Insurance Co. State Farm					Liability Policy No. [REDACTED]			Insurance NAIC Number Unk		
	Driver Condition 1	Sobriety/ Officer Opinion 1	Alcohol: No Drugs: No	Type Alcohol Test Given 6	Alcohol Test Results N/A	Type Drug Test Given 4	Drug Test Results 97	Maneuver 98			
	Most Harmful Event for MV 13	Travel Road Name I-65			Road Code I065	Travel Direction 1	Unit Contributing Circumstance 97	Total Injuries in Unit 0			
	Sequence of Events 23	Event 1 13	Event 2 13	Event 3 97	Event 4 97	First Harmful Event Location 3			Areas Damaged Are Shaded		
	Veh Year 2016	Make DODG	Veh Model RAM 1500 4X4 CREW LONGHOR	Body 2	V.I.N. 1C6RR7PT9GS [REDACTED]						
	Owner's Name Same				License Tag Number [REDACTED]	State AL	Year 2021				
	Street or R.F.D. Same				City [REDACTED]	State AL	Zip [REDACTED]				

Seating Position Codes												
2, 4, or 6 Passenger			9 Passenger (add):			12 Passenger (add):			Bicycle, Motorcycle, ATV		12 - Pedestrian	16 - Not in Passenger Compartment
1	2	3	7	8	9	17	18	19	10	11	13 - Rider of Domestic Animal	97 - Not Applicable
4	5	6									14 - Occ. of Non-Motorized Vehicle	98 - Other (Explain)
											15 - Passenger of Bus	99 - Unknown

UNINJURED OCCUPANTS																	
Unit No	Seat Pos	Occ. Type	Safety Equip.	Air-bag	Age Code	Sex	Ejection	Birth Date	Unit No	Seat Pos	Occ. Type	Safety Equip.	Air-bag	Age Code	Sex	Ejection	Birth Date
1	1	1	2	1	8	1	1	[REDACTED]	3	1	1	2	99	8	1	1	[REDACTED]
3	3	2	2	99	8	2	1	[REDACTED]	3	4	2	2	99	5	1	1	[REDACTED]
3	6	2	2	99	5	1	1	[REDACTED]	4	1	1	2	99	8	1	1	[REDACTED]
4	3	2	2	99	9	2	1	[REDACTED]									

VICTIMS

	N/A <input type="checkbox"/>	Unit No	Seat Pos	Occ. Type	Safety Equip.	Air-bag	Injury Type	Age	Sex	Ejection	First Aid By
Name CANDICE LUZ GULLEY		2	1	1	2	99	2	8	2	1	1
Address [REDACTED]											
Taken To Baptist South Montgomery, AL						Taken By Haynes Ambulance					
Medical Facility EMS ground						Birth Date [REDACTED]					
Name [REDACTED]		2	3	2	2	99	1	5	2	4	97
Address [REDACTED]											
Taken To Alabama Department of Forensic Science						Taken By Butler County EMA					
Medical Facility Not Applicable						Birth Date [REDACTED]					
Name [REDACTED]		2	5	2	5	1	1	1	1	4	97
Address [REDACTED]											
Taken To Alabama Department of Forensic Science						Taken By Butler County EMA					
Medical Facility Not Applicable						Birth Date [REDACTED]					
Name [REDACTED]		2	7	2	2	99	1	4	1	4	97
Address [REDACTED]											
Taken To Alabama Department of Forensic Science						Taken By Butler County EMA					
Medical Facility Not Applicable						Birth Date [REDACTED]					
Name [REDACTED]		2	8	2	2	1	1	5	2	4	97
Address [REDACTED]											
Taken To Alabama Department of Forensic Science						Taken By Butler County EMA					
Medical Facility Not Applicable						Birth Date [REDACTED]					
Name [REDACTED]		2	9	2	2	99	1	3	1	4	97
Address [REDACTED]											
Taken To Alabama Department of Forensic Science						Taken By Butler County EMA					
Medical Facility Not Applicable						Birth Date [REDACTED]					
Name [REDACTED]		2	17	2	2	99	1	6	2	4	97
Address [REDACTED]											
Taken To Alabama Department of Forensic Science						Taken By Butler County EMA					
Medical Facility Not Applicable						Birth Date [REDACTED]					
Name [REDACTED]		2	18	2	2	1	1	6	2	4	1
Address [REDACTED]											
Taken To Alabama Department of Forensic Science						Taken By Butler County EMA					
Medical Facility Not Applicable						Birth Date [REDACTED]					
Name [REDACTED]		2	19	2	2	99	1	6	2	4	97
Address [REDACTED]											
Taken To Alabama Department of Forensic Science						Taken By Butler County EMA					
Medical Facility Not Applicable						Birth Date [REDACTED]					

DIAGRAM

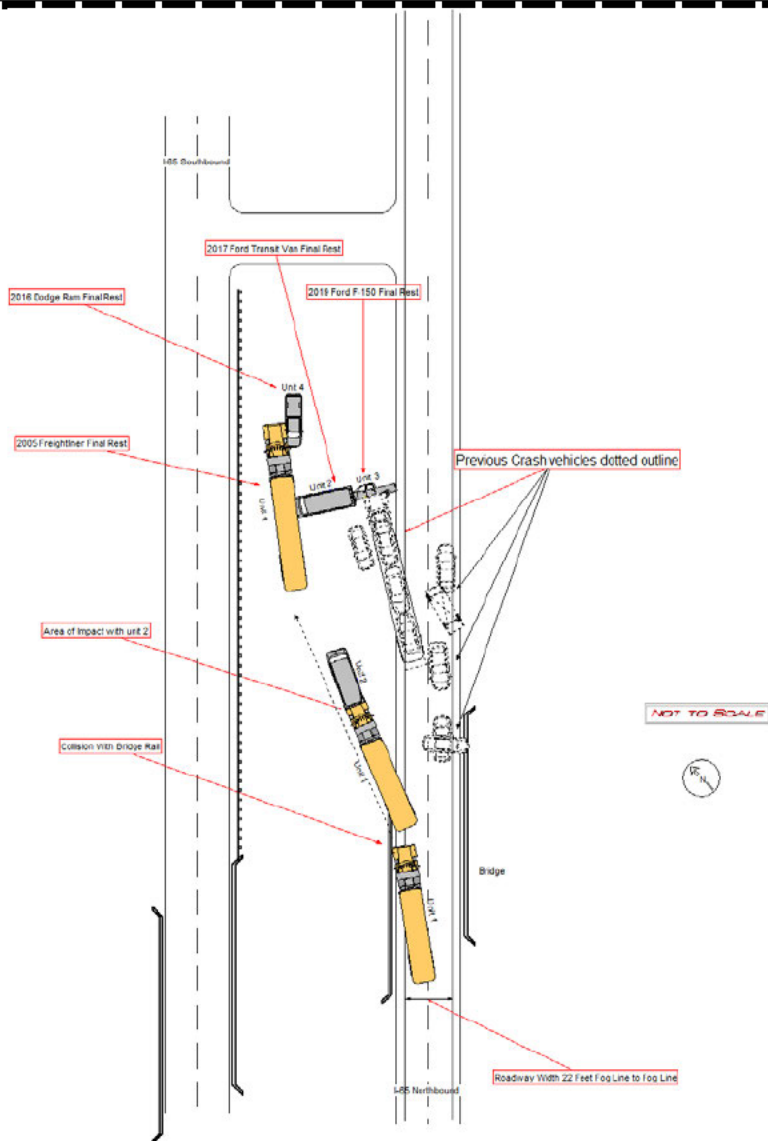

NARRATIVE

Unit 1 was northbound on I-65 in the rain. A multi-vehicle crash occurred ahead of unit 1. Unit 1 was travelling too fast for conditions as he was crossing the bridge. Unit 1 took evasive action, colliding with and riding up on the concrete bridge railing. Unit 1 left the roadway to the left and collided with unit 2, pushing unit 2 through the median. Unit 2 came to final rest between units 1 and 3. Unit 3 was at a stop in the median on its side from the previous crash when unit 2 collided with it at final rest. Unit 1 then collided into the right front of unit 4 when it came to final rest. Unit 4 was in the median as a result of a previous crash. The restraint devices in unit 2 were inspected post crash, and found to have all occupants restraints buckled.

Reference crashes: 1681934, 1681935, and 1681939 for all crashes reported at this scene on this date.

ROADWAY ENVIRONMENT

Unit No.	1	Involved Road/Bridge	1	Road Surface Type	2	Roadway Condition	2	Workzone Related?	1	Workzone Type	97	Workers Present?	NotApplicable	Workzone Law Enforcement Present?	97	Contributing Circumstances Environment	2	Contrib Matl In Roadway	1				
Contrib Material Source	97	Rdway Curve & Grade	1	Vision Obscur ed By	1	Traffic Control	1	Traffic Control Functioning	97	Opposing Lane Separation	6	Trafficway Lanes	4	Turn Lanes	1	One-Way Street	No	Total # Occupant s In Unit	1	Total # Injured in Unit	0	Total # Killed in Unit	0
Total Number of Units		Light			Weather			Locale			Police Present?		DOT Railroad Crossing No.										
4		1			5			1			No		N/A										
Unit No.	2	Involved Road/Bridge	1	Road Surface Type	1	Roadway Condition	2	Workzone Related?	1	Workzone Type	97	Workers Present?	NotApplicable	Workzone Law Enforcement Present?	97	Contributing Circumstances Environment	2	Contrib Matl In Roadway	1				
Contrib Material Source	97	Rdway Curve & Grade	1	Vision Obscur ed By	1	Traffic Control	1	Traffic Control Functioning	97	Opposing Lane Separation	7	Trafficway Lanes	4	Turn Lanes	1	One-Way Street	No	Total # Occupant s In Unit	9	Total # Injured in Unit	1	Total # Killed in Unit	8
Total Number of Units		Light			Weather			Locale			Police Present?		DOT Railroad Crossing No.										
4		1			5			1			No		N/A										
Unit No.	3	Involved Road/Bridge	1	Road Surface Type	1	Roadway Condition	2	Workzone Related?	1	Workzone Type	97	Workers Present?	NotApplicable	Workzone Law Enforcement Present?	97	Contributing Circumstances Environment	2	Contrib Matl In Roadway	1				
Contrib Material Source	97	Rdway Curve & Grade	1	Vision Obscur ed By	1	Traffic Control	1	Traffic Control Functioning	97	Opposing Lane Separation	7	Trafficway Lanes	4	Turn Lanes	1	One-Way Street	No	Total # Occupant s In Unit	4	Total # Injured in Unit	0	Total # Killed in Unit	0
Total Number of Units		Light			Weather			Locale			Police Present?		DOT Railroad Crossing No.										
4		1			5			1			No		N/A										

ROADWAY ENVIRONMENT

Unit No.	4	Involved Road/Bridge	1	Road Surface Type	1	Roadway Condition	2	Workzone Related?	1	Workzone Type	97	Workers Present?	NotApplicable	Workzone Law Enforcement Present?	97	Contributing Circumstances Environment	2	Contrib Matl In Roadway	1				
Contrib Material Source	97	Rdway Curve & Grade	1	Vision Obscured By	1	Traffic Control	1	Traffic Control Functioning	97	Opposing Lane Separation	7	Trafficway Lanes	4	Turn Lanes	1	One-Way Street	No	Total # Occupants In Unit	2	Total # Injured in Unit	0	Total # Killed in Unit	0
Total Number of Units		Light			Weather			Locale			Police Present?		DOT Railroad Crossing No.										
4		1			5			1			No		N/A										

INVESTIGATION

Name of Photographer																					
Glenn L Furukawa																					
Time Police Notified			Time Police Arrived			Time EMS Arrived			EMS Response Run #												
1430 MT			1504 MT			1438 MT			N/A												
Name of Investigating Officer								Officer ID		Agency ORI											
Glenn L Furukawa								1019		ALDPS5500											
Name of Investigating Officer								Officer ID		Agency ORI											
Phillip A Faukner								1106		ALDPS5500											
The data on this report reflects the best knowledge, opinion, and belief regarding the crash, but no warrant is made as to the factual accuracy thereof.																					

Property Damage Description

Description: Concrete Bridge Rail						Address: 2618 Fort Dale Rd. Greenville, AL 36037					
Owner: Alabama Department of Transportation						Telephone: (334) 382-6614					
Non-Vehicular Property Damage Severity											
4											

ALABAMA UNIFORM TRAFFIC CRASH REPORT

Truck/Bus Supplemental Sheet

AST-27B Rev. 06/08



Unit No. 1
(same as on main report)



General Instructions																																																									
<p><i>Complete this form each qualifying vehicle ONLY if the crash meets BOTH of the Following criteria:</i></p> <p>1. The crash involved a qualifying vehicle (a truck with a gross vehicle weight rating (GVWR) or a gross combination weight rating (GCWR) of more than 10,000 pounds, or Haz/Mat placard, or a vehicle designed to carry nine 9 or more, including driver) and;</p> <p>2. The crash resulted in at least one of the following: A. one or more fatalities B. one or more persons injured and taken from the scene for immediate medical attention, or C. one or more involved vehicles had to be towed from the scene as a result of disabling damage or had to receive assistance to leave.</p>																																																									
Screening Information																																																									
<p><i>Number of Qualifying Vehicles:</i></p> <p>Trucks with GVWR or GCWR of more than 10,000 pounds or Haz/Mat placard <u>1</u></p> <p>Buses designed to carry 9 or more (including driver) <u>1</u></p>	<p><i>Number of Persons:</i></p> <p>Sustaining fatal injuries <u>8</u></p> <p>Transported for immediate medical treatment <u>1</u></p> <p>Number of vehicles towed from scene due to damage <u>4</u></p>																																																								
Vehicle Information																																																									
<p><i>Weight Rating of Power Unit of the Truck</i></p> <p>3. - More than 26,000 pounds</p>	<p><i>Hazardous Material Involvement</i></p> <p>Did vehicle have a Haz/Mat placard? <input type="checkbox"/></p> <p>If Yes, include following information from placard</p> <p>A. Name or 4-digit number from Diamond or box _____</p> <p>B. The 1-digit number from bottom of diamond _____</p> <p>Was hazardous material released from THIS vehicle's cargo? <input type="checkbox"/></p>																																																								
<p><i>Vehicle Configuration</i></p> <p>9. - Tractor with semi-trailer</p>	<p><i>Bus Usage</i></p> <p>1. - Not a bus</p>																																																								
<p><i>Cargo Body Type</i></p> <p>3. - Van / enclosed box</p>	<p><i>Cargo Type</i></p> <p>10. - General freight</p>																																																								
Motor Carrier Information																																																									
<p>NOTE: If NOT a motor carrier, enter NONE under Carrier Name, 0 for None under Carrier Identification Numbers, and go to Sequence Of Events Section</p>																																																									
<p>Carrier Name <u>A SMAT Investment LLC</u></p> <p>Carrier Phone _____</p> <p>Carrier Mailing Address (Street or P.O. Box) <u>887 N INDIAN CREEK DR STE E</u></p> <p>City, State, Zip <u>Clarkston, GA 30021</u></p> <p style="text-align: right;">None = 0)</p> <p>Motor Carrier Type <u>1. - Interstate carrier</u></p> <p>US DOT <u>2506000</u> ICC MC <u>868796</u> STATE NO. <u>Unk</u></p> <p>STATE _____ OTHER COUNTRY AUTHORITY _____ COUNTRY <u>Unk</u></p>																																																									
Sequence of Events																																																									
<p>NOTE: for THIS vehicle -- list up to four</p> <table style="width: 100%; border-collapse: collapse;"> <tr> <td style="width: 25%;">Event #1</td> <td style="width: 25%; text-align: center;"><u>1</u></td> <td style="width: 25%;">Event #2</td> <td style="width: 25%; text-align: center;"><u>18</u></td> <td style="width: 25%;">Event #3</td> <td style="width: 25%; text-align: center;"><u>13</u></td> <td style="width: 25%;">Event #4</td> <td style="width: 25%; text-align: center;"><u>6</u></td> </tr> </table>		Event #1	<u>1</u>	Event #2	<u>18</u>	Event #3	<u>13</u>	Event #4	<u>6</u>																																																
Event #1	<u>1</u>	Event #2	<u>18</u>	Event #3	<u>13</u>	Event #4	<u>6</u>																																																		
EVENT CODES	<table style="width: 100%; border-collapse: collapse;"> <tr> <td style="width: 15%;">Non-Collision</td> <td style="width: 15%;">1. Ran off road</td> <td style="width: 15%;">2. Jackknife</td> <td style="width: 15%;">3. Overturned (rollover)</td> <td style="width: 15%;">4. Downhill runaway</td> <td style="width: 15%;"></td> <td style="width: 15%;"></td> <td style="width: 15%;"></td> </tr> <tr> <td></td> <td>5. Cargo loss or shift</td> <td>6. Explosion or fire</td> <td>7. Separation of units</td> <td>8. Cross median/centerline</td> <td></td> <td></td> <td></td> </tr> <tr> <td></td> <td colspan="3">9. Equipment Failure (brake failure, blown tires, etc.)</td> <td>10. Other non-collision</td> <td colspan="3">11. Unknown</td> </tr> <tr> <td></td> <td>12. Pedestrian</td> <td colspan="2">13. Motor Vehicle in Transport</td> <td colspan="2">14. Parked Motor Vehicle</td> <td colspan="2">15. Train</td> </tr> <tr> <td></td> <td>16. Pedalcycle</td> <td>17. Animal</td> <td>18. Fixed object</td> <td colspan="4">19. Work Zone Maintenance equipment</td> </tr> <tr> <td></td> <td colspan="2">20. Other movable object</td> <td colspan="5">21. Unknown movable object</td> </tr> <tr> <td></td> <td colspan="7">Not applicable 97. Not applicable</td> </tr> </table>	Non-Collision	1. Ran off road	2. Jackknife	3. Overturned (rollover)	4. Downhill runaway					5. Cargo loss or shift	6. Explosion or fire	7. Separation of units	8. Cross median/centerline					9. Equipment Failure (brake failure, blown tires, etc.)			10. Other non-collision	11. Unknown				12. Pedestrian	13. Motor Vehicle in Transport		14. Parked Motor Vehicle		15. Train			16. Pedalcycle	17. Animal	18. Fixed object	19. Work Zone Maintenance equipment					20. Other movable object		21. Unknown movable object						Not applicable 97. Not applicable						
Non-Collision	1. Ran off road	2. Jackknife	3. Overturned (rollover)	4. Downhill runaway																																																					
	5. Cargo loss or shift	6. Explosion or fire	7. Separation of units	8. Cross median/centerline																																																					
	9. Equipment Failure (brake failure, blown tires, etc.)			10. Other non-collision	11. Unknown																																																				
	12. Pedestrian	13. Motor Vehicle in Transport		14. Parked Motor Vehicle		15. Train																																																			
	16. Pedalcycle	17. Animal	18. Fixed object	19. Work Zone Maintenance equipment																																																					
	20. Other movable object		21. Unknown movable object																																																						
	Not applicable 97. Not applicable																																																								

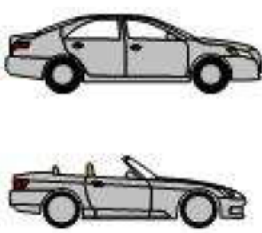
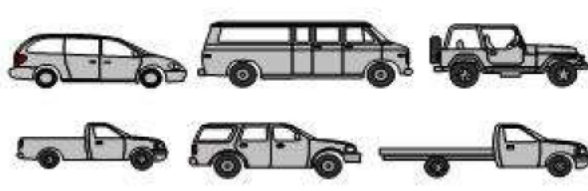
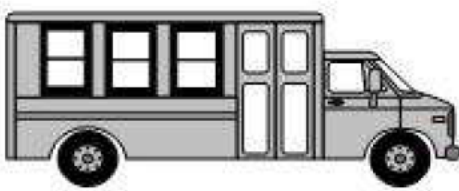

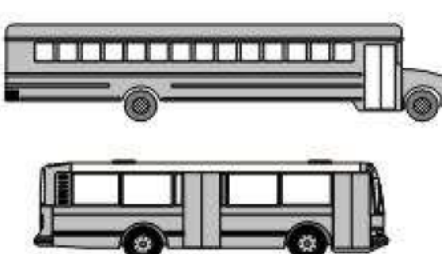
Definitions	
<p style="text-align: center;">Truck</p> <p>A motor vehicle designed, used or maintained primarily for the transportation of property. For the purpose of this form the vehicle must also meet one of the following criteria:</p> <ul style="list-style-type: none"> * Have a GVWR or a GCWR of more than 10,000 pounds, or * Carry a Hazardous Material Placard <p style="text-align: center;">Bus</p> <p>A motor vehicle providing seats for 9 or more persons including the driver and used primarily for the transportation of persons.</p> <p style="text-align: center;">Trailer</p> <p>A non-power vehicle towed by a motor vehicle.</p>	<p style="text-align: center;">Reportable Crash</p> <p>A highway related incident normally investigated by a police officer and reported on a standard crash report form involving one or more trucks or buses (as defined here) which results in:</p> <ul style="list-style-type: none"> * One or more fatalities, or * One or more non-fatal injuries requiring transportation for the purpose of obtaining immediate medical treatment, or * One or more of the vehicles being removed from the scene as a result of disabling damage, or * One or more of the vehicles requiring intervening assistance before proceeding under its own power.

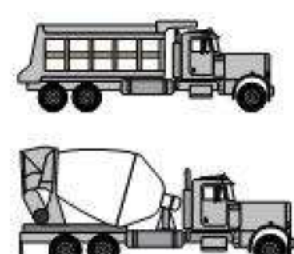
Typical Vehicle Silhouettes

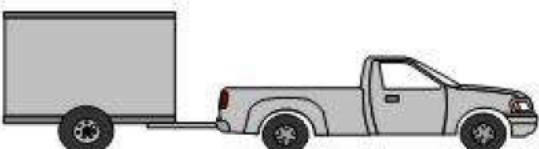
<p>1. Passenger Vehicle</p> 	<p>2. Light truck (van, mini-van, panel, pickup, sport utility vehicle)</p> 	<p>3. Bus (seats for 9-15 people, including driver)</p> 
--	---	---

<p>4. Bus (seats for more than 15 people, including driver)</p> 	<p>5. Single unit truck - 2 axles / 6 tires</p> 	<p>6. Single unit truck - 3 axles</p> 
--	--	--

<p>7. Truck with trailer</p> 	<p>8. Truck tractor (bobtail)</p> 	<p>9.</p> 
---	---	--

<p>10. Tractor with double trailers</p> 	<p>11. Tractor with triple trailers</p> 
--	--

Typical Hazardous Material Placards



LEGEND

Location	Category	Code	Description	Location	Category	Code	Description
Report Header	Unit Type	11	Tractor / semi-trailer	Driver	Liability Ins. Policy Code	0	Not Set
Report Header	Unit Type	27	Small bus (seats 9-15, including driver)	Driver	Liability Insurance NAIC Number Code		Not Set
Location And Time	Contributing Circumstance	7	Driving too fast for conditions	Driver	Liability Insurance NAIC Number Code	Unk	Unknown
Location And Time	Contributing Unit	10	Unit1	Driver	Maneuver	1	Movement essentially straight
Location And Time	Controlled Access Highway Location	1	Main road	Driver	Maneuver	98	Other (explain in narrative)
Location And Time	Coordinate Status	Known	Known	Driver	Phone Number Code	0	Not Set
Location And Time	Coordinate Type	1	From computerized map	Driver	Place of Employment		Not Set
Location And Time	Crash Manner	7	Rear end (front-to-rear)	Driver	Place of Employment	Retired	Retired
Location And Time	Crash Severity	K	Fatal Injury	Driver	Race	1	White / Caucasian
Location And Time	Distance Node Unit	20	Miles	Driver	Race	2	Black / African-American
Location And Time	Distracted Driving	97	Not applicable (not distracted)	Driver	Residence Within 25 Miles	No	No
Location And Time	Harmful Event	13	Fire / explosion	Driver	Travel Direction	1	North
Location And Time	Harmful Event	32	Collision with bridge abutment / rail	Vehicle	Attachment	1	None
Location And Time	Highway Classification	1	Interstate	Vehicle	Attachment	4	Other semi trailer
Location And Time	Highway Side	1	Northbound	Vehicle	Body	2	Four door
Location And Time	Roadway Feature	2	Bridge / overpass / underpass	Vehicle	Body	97	Not applicable - not passenger car, personal van, or SUV
Location And Time	School Bus Related	1	No school bus involved	Vehicle	Citation Offense	99	None
Location And Time	Time Display Format	20	Military	Vehicle	Damage Severity	4	Major, disabled
Driver	Alcohol Test Type	1	Blood test	Vehicle	Defect	1	None
Driver	Alcohol Test Type	6	No Test Given	Vehicle	Emergency Status	97	Not applicable
Driver	Commercial Driver License Status	97	Not applicable / unlicensed	Vehicle	Estimated Speed Code		Not set
Driver	Commercial Driver License Status	C	Current / valid	Vehicle	Estimated Speed Code	000	Stationary
Driver	Contributing Circumstance	7	Driving too fast for conditions	Vehicle	Hazardous Cargo	1	None
Driver	Contributing Circumstance	97	Not applicable	Vehicle	Hazardous Cargo	97	Not applicable
Driver	Driver Address Code	0	Not Set	Vehicle	Hazardous Cargo Release Type	97	Not applicable
Driver	Driver Condition	1	Apparently normal	Vehicle	K12 Child Going To Or From School	0	Not Set
Driver	Driver License Class Code	0	Not set	Vehicle	Make	DODG	Dodge
Driver	Driver License Endorsement	97	Not applicable	Vehicle	Make	FORD	Ford
Driver	Driver License Number	0	Not set	Vehicle	Make	FRHT	Freightliner
Driver	Driver License Restriction	97	Not applicable	Vehicle	Non-Motorist Action	0	Not Set
Driver	Driver License State Code	0	Not set	Vehicle	Non-Motorist Location	0	Not Set
Driver	Driver License Status	C	Current / valid	Vehicle	Oversized Load	N/A	NotApplicable
Driver	Driver Name Code	0	Not Set	Vehicle	Oversized Load	No	No
Driver	Drug Test Result	97	Not applicable	Vehicle	Oversized Load Permit	N/A	NotApplicable
Driver	Drug Test Result	99	Unknown	Vehicle	Owner Address Code	0	Not Set
Driver	Drug Test Type	1	Blood test	Vehicle	Owner Address Code	Same	Same
Driver	Drug Test Type	4	No test given	Vehicle	Owner Name Code		Not Set
Driver	Gender	1	Male	Vehicle	Owner Name Code	Same	Same as driver
Driver	Gender	2	Female	Vehicle	Placard Requirement	2	No
Driver	Harmful Event	13	Fire / explosion	Vehicle	Placard Requirement	97	Not applicable

LEGEND

Location	Category	Code	Description	Location	Category	Code	Description
Vehicle	Placard Status	3	Not applicable (placard not required)	Victims	Gender	2	Female
Vehicle	Tag Number		Not set	Victims	Injury Type	1	(K) Fatal
Vehicle	Tag State	0	Not set	Victims	Injury Type	2	(A) Suspected serious injury
Vehicle	Tag Year	0	Not set	Victims	Medical Facility Transport	2	EMS ground
Vehicle	Tow Status	1	Towed due to disabling damage	Victims	Medical Facility Transport	97	Not Applicable
Vehicle	Towed Code	0	Not Set	Victims	Occupant Type	1	Driver
Vehicle	Unit Type	11	Tractor / semi-trailer	Victims	Occupant Type	2	Passenger
Vehicle	Unit Type	27	Small bus (seats 9-15, including driver)	Victims	Safety Equipment	2	Shoulder and lap belt used
Vehicle	Unit Type	3	Pick-up	Victims	Safety Equipment	5	Forward facing child safety seat used properly
Vehicle	Usage	1	Personal vehicle	Victims	Victim Taken By		Not Set
Vehicle	Usage	30	Other bus (explain in narrative)	Victims	Victim Taken To		Not Set
Vehicle	Usage	6	Cargo Transportation	Roadway Environment	Environmental Contributing Circumstance	2	Weather
Vehicle	VIN	0	Not set	Roadway Environment	Light Condition	1	Daylight
Vehicle	Year		Not set	Roadway Environment	Locale	1	Open country
Uninjured Occupants	Age Code	5	13 - 15	Roadway Environment	Opposing Lane Separation	6	Concrete barrier
Uninjured Occupants	Age Code	8	26 - 64	Roadway Environment	Opposing Lane Separation	7	Metal guard rail
Uninjured Occupants	Age Code	9	65 or older	Roadway Environment	Road Bridge Condition	1	None apparent
Uninjured Occupants	Airbag	1	Not installed	Roadway Environment	Road Surface Type	1	Asphalt
Uninjured Occupants	Airbag	99	Unknown	Roadway Environment	Road Surface Type	2	Concrete
Uninjured Occupants	Birth Date Code	0	Not Set	Roadway Environment	Roadway Condition	2	Wet
Uninjured Occupants	Ejection Status	1	Not ejected or trapped	Roadway Environment	Roadway Curvature And Grade	1	Straight, level
Uninjured Occupants	Gender	1	Male	Roadway Environment	Roadway Material	1	None
Uninjured Occupants	Gender	2	Female	Roadway Environment	Roadway Material Source	97	Not applicable
Uninjured Occupants	Occupant Type	1	Driver	Roadway Environment	Traffic Control	1	No controls present
Uninjured Occupants	Occupant Type	2	Passenger	Roadway Environment	Traffic Control Status	97	Not applicable
Uninjured Occupants	Safety Equipment	2	Shoulder and lap belt used	Roadway Environment	Trafficway Lane Count	4	Four lanes
Victims	Age Code	1	0 - 3	Roadway Environment	Turn Lane Presence	1	None
Victims	Age Code	3	6 - 8	Roadway Environment	Vision Obscuration	1	Not obscured
Victims	Age Code	4	9 - 12	Roadway Environment	Weather Condition	5	Rain
Victims	Age Code	5	13 - 15	Roadway Environment	Workzone Law Enforcement Presence	97	Not applicable
Victims	Age Code	6	16 - 20	Roadway Environment	Workzone Relationship	1	Not in / related to workzone
Victims	Age Code	8	26 - 64	Roadway Environment	Workzone Type	97	Not applicable
Victims	Airbag	1	Not installed	Investigation	Non-Vehicular Property Damage Severity	4	Severe (over \$10,000)
Victims	Airbag	99	Unknown	Truck/Bus Supplement	Bus Usage	1	Not a bus
Victims	Birth Date Code	0	Not Set	Truck/Bus Supplement	Bus Usage	98	Other (explain in narrative)
Victims	Ejection Status	1	Not ejected or trapped	Truck/Bus Supplement	Cargo Body Type	1	Bus (9-15 passengers, including driver)
Victims	Ejection Status	4	Trapped within vehicle	Truck/Bus Supplement	Cargo Body Type	3	Van / enclosed box
Victims	First Aid Provider	1	Paramedic / EMT	Truck/Bus Supplement	Cargo Type	10	General freight
Victims	First Aid Provider	97	None - no first aid	Truck/Bus Supplement	Cargo Type	24	Passenger
Victims	Gender	1	Male	Truck/Bus Supplement	Carrier Address Code	0	Not Set

LEGEND

Location	Category	Code	Description	Location	Category	Code	Description
Truck/Bus Supplement	Carrier Name Code	0	Not Set				
Truck/Bus Supplement	Carrier Phone Code	0	Not Set				
Truck/Bus Supplement	Country Number Code	Unk	Unknown				
Truck/Bus Supplement	ICCMC Number Code	0	Not Set				
Truck/Bus Supplement	ICCMC Number Code	Unk	Unknown				
Truck/Bus Supplement	Motor Carrier Type	1	Interstate carrier				
Truck/Bus Supplement	Motor Carrier Type	2	Intrastate carrier				
Truck/Bus Supplement	State Number Code	Unk	Unknown				
Truck/Bus Supplement	USDOT Number Code	0	Not Set				
Truck/Bus Supplement	USDOT Number Code	Unk	Unknown				
Truck/Bus Supplement	Vehicle Configuration	3	Bus (seats for 9 - 15 people, including driver)				
Truck/Bus Supplement	Vehicle Configuration	9	Tractor with semi-trailer				
Truck/Bus Supplement	Weight Rating	1	Less than or equal to 10,000 pounds				
Truck/Bus Supplement	Weight Rating	3	More than 26,000 pounds				