



SURVIVAL FACTORS ATTACHMENT

Alabama Uniform Traffic Crash Report 1681935

Greenville, AL

HWY21MH009

(17 pages)

ALABAMA UNIFORM TRAFFIC CRASH REPORT

Crash Report Case No. 1681935

Check if Amendment

Check if Error Correction

# Vehicles	# Pedestrians	# Injured	# Fatalities	# Unit 1 Type	# Unit 2 Type
10	0	19	2	11	6

Local Case No. MAIT38-21-129

Sheet 1

LOCATION AND TIME

Date: 06/19/2021
Time: 1420 MT
Day of Week: Sat
County: Butler
City: Rural Butler
Rural Local Zone: N/A

Hwy Class: 1
On Street, Road, Highway: I-65
At Intersection of or Between (Node 1): Fort Deposit Road
And (Node 2): Crossover

Mile Post: 1065
(On) Street/Road/Hwy ← Code: 7640
Node Code: 1 2
From Node 1: 1.64 Miles

Control Access Hwy Loc: 1
Primary Contrib Circums: 7
Primary Contributing Unit #: 1
First Harmful Event Location: 22
Most Harmful Event Location: 22

Distance to Fixed Object: N/A feet
Roadway Junction/Feature: 2
Manner of Crash: 7
Lat Coordinate: 31° 56' 42.703" N
Long Coordinate: 86° 33' 32.751" W
Coordinate Type: 1
Hwy Side: 1

School Bus Related: 1
Crash Severity: K
Distracted Driving: 97

DRIVER

1 UNIT NO

LEFT SCENE

COM VEH

VEHICLE or NON-MOTORIST

Driver Full Name: JAMES B WOODFORK
City and State: GARDENDALE AL
ZIP: 35071

DOB: [Redacted] Race: 2 Sex: 1 DL State: AL Driver License No.: [Redacted] DL Class: A DL Status: C Restrict Violations: 97 CDL Status: C Endorse Violations: 97

Place of Employment: Hansen/Adkins Auto Transport LLC
Residence Less Than 25 Miles: No

Liability Insurance Co.: Hudson Insurance Company
Liability Policy No.: [Redacted] Insurance NAIC Number: Unk

Driver Condition: 1
Sobriety/Officer Opinion: No
Alcohol: No
Type Alcohol Test Given: 1
Alcohol Test Results: Unk
Type Drug Test Given: 1
Drug Test Results: 99
Maneuver: 1

Most Harmful Event for MV: 22
Travel Road Name: I-65
Road Code: I065
Travel Direction: 1
Unit Contributing Circumstance: 7
Total Injuries in Unit: 1

Sequence of Events:
Event 1: 22
Event 2: 22
Event 3: 32
Event 4: 22
First Harmful Event Location: 1

Veh Year: 2020 Make: VOLV Veh Model: T/T Body: 97 V.I.N.: 4V5RC9EH7LN [Redacted]

Owner's Name: Hansen and Adkins Auto Transport Inc.
License Tag Number: [Redacted] State: CA Year: 2021

Street or R.F.D.: [Redacted] City: Los Alamitos State: CA Zip: 90720

Type: 11 Usage: 6 Emergency Status: 97 Placard Status: 3 Placard Required: 2 Hazardous Cargo: 1 Hazardous Cargo Released?: 97

Attachment: 4 Oversized Load: No If Yes, Did Owner Have Permit?: N/A Contrib Defect: 1 Speed Limit: 70 MPH Est Speed: 70 MPH Citation Offense(s) Charged: None

Damage Severity: 4 Towed?: 1 Vehicle Towed By Whom: Till's Towing (ROT/THI)
Towed To Where: Till's Towing (Greenville, AL)

Areas Damaged Are Shaded: 14 Under Carriage

Point of Initial Impact: 12

DRIVER

2 UNIT NO

LEFT SCENE

COM VEH

VEHICLE or NON-MOTORIST

Driver Full Name: Hayle E Morgan
City and State: South Pittsburg TN
ZIP: 380-7024 Telephone: [Redacted]

DOB: [Redacted] Race: 1 Sex: 2 DL State: TN Driver License No.: [Redacted] DL Class: D DL Status: C Restrict Violations: 97 CDL Status: 97 Endorse Violations: 97

Place of Employment: 99
Residence Less Than 25 Miles: No

Liability Insurance Co.: Allstate
Liability Policy No.: [Redacted] Insurance NAIC Number: Unk

Driver Condition: 1
Sobriety/Officer Opinion: No
Alcohol: No
Type Alcohol Test Given: 1
Alcohol Test Results: Unk
Type Drug Test Given: 1
Drug Test Results: 99
Maneuver: 15

Most Harmful Event for MV: 22
Travel Road Name: I-65
Road Code: I065
Travel Direction: 1
Unit Contributing Circumstance: 97
Total Injuries in Unit: 4

Sequence of Events:
Event 1: 22
Event 2: 22
Event 3: 11
Event 4: 97
First Harmful Event Location: 1

Veh Year: 2020 Make: FORD Veh Model: XPL Body: 4 V.I.N.: 1FMSK8DH6LGC [Redacted]

Owner's Name: Cody Fox
License Tag Number: [Redacted] State: TN Year: 2021

Street or R.F.D.: Same City: [Redacted] State: TN Zip: [Redacted]

Type: 6 Usage: 1 Emergency Status: 97 Placard Status: 3 Placard Required: 97 Hazardous Cargo: 97 Hazardous Cargo Released?: 97

Attachment: 1 Oversized Load: N/A If Yes, Did Owner Have Permit?: N/A Contrib Defect: 1 Speed Limit: 70 MPH Est Speed: 000 MPH Citation Offense(s) Charged: None

Damage Severity: 4 Towed?: 1 Vehicle Towed By Whom: Till's Towing (ROT/THI)
Towed To Where: Till's Towing (Greenville, AL)

Areas Damaged Are Shaded: 14 Under Carriage

Point of Initial Impact: 12

<input type="checkbox"/> UNIT NO <input type="checkbox"/> LEFT SCENE <input type="checkbox"/> COM VEH <input checked="" type="checkbox"/> VEHICLE or <input type="checkbox"/> NON-MOTORIST	Driver Full Name KACI BETHUNE PRUITT	Street Address [REDACTED]	City and State NEW SITE AL	ZIP 36256	Telephone [REDACTED]					
	DOB Month: [REDACTED] Day: [REDACTED] Year: [REDACTED]	Race: 1	Sex: 2	DL State: AL	Driver License No.: 6463639	DL Class: D	DL Status: C	Restrict Violations: 97	CDL Status: 97	Endorse Violations: 97
	Place of Employment Tallapoosa County Sheriff Dept. (Dadeville, AL)							Residence Less Than 25 Miles No		
	Liability Insurance Co. Progressive				Liability Policy No. [REDACTED]		Insurance NAIC Number			
	Driver Condition: 1	Sobriety/ Officer Opinion: No	Alcohol: No	Type Alcohol Test Given: 1	Alcohol Test Results: Unk	Type Drug Test Given: 1	Drug Test Results: 99	Maneuver: 15		
	Most Harmful Event for MV: 22	Travel Road Name: I-65			Road Code: I065	Travel Direction: 1	Unit Contributing Circumstance: 97	Total Injuries in Unit: 2		
	Sequence of Events: 22	Event 1: 22	Event 2: 22	Event 3: 97	Event 4: 97	First Harmful Event Location: 1		Areas Damaged Are Shaded		
	Veh Year: 2017	Make: BUIC	Veh Model: LACROSSE PREFERRED 3	Body: 2	V.I.N.: 1G4ZN5SS8HU [REDACTED]		14 Under Carriage			
	Owner's Name: Same			License Tag Number: [REDACTED]	State: AL	Year: 2021	11 12 1 1 10 2 9 13 3 16 8 4 7 5 6 15 Attachment			
	Street or R.F.D.: Same			City: [REDACTED]	State: [REDACTED]	Zip: [REDACTED]	Point of Initial Impact: 6			

<input type="checkbox"/> UNIT NO <input type="checkbox"/> LEFT SCENE <input type="checkbox"/> COM VEH <input checked="" type="checkbox"/> VEHICLE or <input type="checkbox"/> NON-MOTORIST	Driver Full Name ALESHA KAY SUMMERS	Street Address [REDACTED]	City and State FULTONDALE AL	ZIP 35068	Telephone [REDACTED]					
	DOB Month: [REDACTED] Day: [REDACTED] Year: [REDACTED]	Race: 1	Sex: 2	DL State: AL	Driver License No.: [REDACTED]	DL Class: D	DL Status: C	Restrict Violations: 97	CDL Status: 97	Endorse Violations: 97
	Place of Employment AAABCO Mini Storage (Birmingham, AL)							Residence Less Than 25 Miles No		
	Liability Insurance Co. Progressive				Liability Policy No. [REDACTED]		Insurance NAIC Number			
	Driver Condition: 6	Sobriety/ Officer Opinion: No	Alcohol: Yes	Type Alcohol Test Given: 1	Alcohol Test Results: Unk	Type Drug Test Given: 1	Drug Test Results: 99	Maneuver: 15		
	Most Harmful Event for MV: 22	Travel Road Name: I-65			Road Code: I065	Travel Direction: 1	Unit Contributing Circumstance: 97	Total Injuries in Unit: 2		
	Sequence of Events: 22	Event 1: 22	Event 2: 22	Event 3: 97	Event 4: 97	First Harmful Event Location: 1		Areas Damaged Are Shaded		
	Veh Year: 2020	Make: ACUR	Veh Model: TLX ADVANCE V6 AWD 3	Body: 2	V.I.N.: 19UUB3F87LA [REDACTED]		14 Under Carriage			
	Owner's Name: Same			License Tag Number: [REDACTED]	State: AL	Year: 2021	11 12 1 1 10 2 9 13 3 16 8 4 7 5 6 15 Attachment			
	Street or R.F.D.: Same			City: [REDACTED]	State: [REDACTED]	Zip: [REDACTED]	Point of Initial Impact: 6			

5 UNIT NO <input type="checkbox"/> LEFT SCENE <input type="checkbox"/> COM VEH <input checked="" type="checkbox"/> VEHICLE or <input type="checkbox"/> NON-MOTORIST	Driver Full Name CANDICE LUZ GULLEY		Street Address [REDACTED]				City and State CAMP HILL AL			ZIP 36850	Telephone [REDACTED]
	DOB Month Day Year [REDACTED] [REDACTED] [REDACTED]	Race 1	Sex 2	DL State AL	Driver License No. [REDACTED]		DL Class D	DL Status C	Restrict Violations 97	CDL Status 97	Endorse Violations 97
	Place of Employment Tallapoosa County Girls Ranch (Camp Hill, AL)								Residence Less Than 25 Miles No		
	Liability Insurance Co. AmGuard Insurance Company						Liability Policy No. [REDACTED]		Insurance NAIC Number Unk		
	Driver Condition 1	Sobriety/ Officer Opinion No		Alcohol: No	Type Alcohol Test Given 1	Alcohol Test Results Unk	Type Drug Test Given 1	Drug Test Results 99	Maneuver 1		
	Most Harmful Event for MV 22	Travel Road Name I-65				Road Code I065	Travel Direction 1	Unit Contributing Circumstance 97	Total Injuries in Unit 0		
	Sequence of Events	Event 1 22	Event 2 3	Event 3 97	Event 4 97	First Harmful Event Location 1		Areas Damaged Are Shaded			
	Veh Year 2017	Make FORD	Veh Model TRANSIT-350 WAGON T-		Body 98	V.I.N. 1FBZX2YM2HKE [REDACTED]		14 Under Carriage 			
	Owner's Name Tallapoosa County Girls Ranch				License Tag Number [REDACTED]	State AL	Year 2021	11 10 9 8 7 6 13 1 2 3 4 5 15 Attachment Point of Initial Impact 2			
	Street or R.F.D. 174 SAMFORD DR			City CAMP HILL		State AL	Zip 36850				

6 UNIT NO <input type="checkbox"/> LEFT SCENE <input type="checkbox"/> COM VEH <input checked="" type="checkbox"/> VEHICLE or <input type="checkbox"/> NON-MOTORIST	Driver Full Name Steven Ray Lenga		Street Address [REDACTED]				City and State Pensacola FL			ZIP 32503	Telephone [REDACTED]
	DOB Month Day Year [REDACTED] [REDACTED] [REDACTED]	Race 1	Sex 1	DL State FL	Driver License No. [REDACTED]		DL Class E	DL Status C	Restrict Violations 97	CDL Status 97	Endorse Violations 97
	Place of Employment West Florida Hospitals, Pensacola, Florida								Residence Less Than 25 Miles No		
	Liability Insurance Co. USAA						Liability Policy No. [REDACTED]		Insurance NAIC Number Unk		
	Driver Condition 1	Sobriety/ Officer Opinion No		Alcohol: No	Type Alcohol Test Given 1	Alcohol Test Results Unk	Type Drug Test Given 1	Drug Test Results 99	Maneuver 98		
	Most Harmful Event for MV 22	Travel Road Name I-65				Road Code I065	Travel Direction 1	Unit Contributing Circumstance 97	Total Injuries in Unit 1		
	Sequence of Events	Event 1 6	Event 2 22	Event 3 32	Event 4 3	First Harmful Event Location 1		Areas Damaged Are Shaded			
	Veh Year 2017	Make VOLK	Veh Model Passat		Body 2	V.I.N. 1VWBT7A36HC [REDACTED]		14 Under Carriage 			
	Owner's Name Same				License Tag Number [REDACTED]	State FL	Year 2022	11 10 9 8 7 6 13 1 2 3 4 5 15 Attachment Point of Initial Impact 6			
	Street or R.F.D. Same			City [REDACTED]		State FL	Zip [REDACTED]				

7 UNIT NO <input type="checkbox"/> LEFT SCENE <input type="checkbox"/> COM VEH <input checked="" type="checkbox"/> VEHICLE or <input type="checkbox"/> NON-MOTORIST	Driver Full Name JAMES RAFF WHITE		Street Address [REDACTED]				City and State BRYANT AL		ZIP 35958	Telephone [REDACTED]	
	DOB Month Day Year [REDACTED]	Race 1	Sex 1	DL State AL	Driver License No. [REDACTED]		DL Class BM	DL Status C	Restrict Violations 97	CDL Status C	Endorse Violations 97
	Place of Employment Marion Environmental (Chattanooga, TN)								Residence Less Than 25 Miles No		
	Liability Insurance Co. GEICO						Liability Policy No. [REDACTED]		Insurance NAIC Number		
	Driver Condition 1	Sobriety/ Officer Opinion No	Alcohol: No No	Type Alcohol Test Given 1	Alcohol Test Results Unk	Type Drug Test Given 1	Drug Test Results 99	Maneuver 15			
	Most Harmful Event for MV 22	Travel Road Name I-65			Road Code I065	Travel Direction 1	Unit Contributing Circumstance 97	Total Injuries in Unit 5			
	Sequence of Events	Event 1 22	Event 2 22	Event 3 22	Event 4 97	First Harmful Event Location 1					
	Veh Year 2017	Make KIA	Veh Model SEDONA LX 6G 3.3		Body 4	V.I.N. KNDMB5C13H [REDACTED]					
	Owner's Name Same				License Tag Number [REDACTED]	State AL	Year 2021				
	Street or R.F.D. Same				City	State	Zip				
Type 33	Usage 1	Emergency Status 97	Placard Status 3	Placard Required 97	Hazardous Cargo 97	Hazardous Cargo Released? 97					
Attachment 1	Oversized Load N/A	If Yes, Did Owner Have Permit? N/A	Contrib Defect 1	Speed Limit 70 MPH	Est Speed 000 MPH	Citation Offense(s) Charged None					
Damage Severity 4	Towed? 1	Vehicle Towed By Whom: Scott's Towing (ROT/THI)									
Towed To Where: Till's Towing											

8 UNIT NO <input type="checkbox"/> LEFT SCENE <input type="checkbox"/> COM VEH <input checked="" type="checkbox"/> VEHICLE or <input type="checkbox"/> NON-MOTORIST	Driver Full Name Jason Ryan Estep		Street Address [REDACTED]				City and State Picayune MS		ZIP 39466	Telephone [REDACTED]	
	DOB Month Day Year [REDACTED]	Race 1	Sex 1	DL State MS	Driver License No. [REDACTED]		DL Class Operat	DL Status C	Restrict Violations 97	CDL Status 97	Endorse Violations 97
	Place of Employment Poplar Dental Clinic (Picayune, Ms.)								Residence Less Than 25 Miles No		
	Liability Insurance Co. Rental Insurance						Liability Policy No. 99		Insurance NAIC Number Unk		
	Driver Condition 1	Sobriety/ Officer Opinion No	Alcohol: No No	Type Alcohol Test Given 1	Alcohol Test Results Unk	Type Drug Test Given 1	Drug Test Results 99	Maneuver 15			
	Most Harmful Event for MV 22	Travel Road Name I-65			Road Code I065	Travel Direction 1	Unit Contributing Circumstance 97	Total Injuries in Unit 0			
	Sequence of Events	Event 1 22	Event 2 22	Event 3 97	Event 4 97	First Harmful Event Location 1					
	Veh Year 2021	Make CHRY	Veh Model PACI		Body 4	V.I.N. 2C4RC3GG3MR [REDACTED]					
	Owner's Name HOLDINGS LLC EAN				License Tag Number [REDACTED]	State MS	Year 2022				
	Street or R.F.D. 6148 US Highway 98				City Httisburg	State MS	Zip 39402				
Type 6	Usage 1	Emergency Status 97	Placard Status 3	Placard Required 97	Hazardous Cargo 97	Hazardous Cargo Released? 97					
Attachment 1	Oversized Load N/A	If Yes, Did Owner Have Permit? N/A	Contrib Defect 1	Speed Limit 70 MPH	Est Speed 000 MPH	Citation Offense(s) Charged None					
Damage Severity 4	Towed? 1	Vehicle Towed By Whom: Till's Towing (ROT/THI)									
Towed To Where: Till's Towing (Greenville, AL)											

9 UNIT NO LEFT SCENE COM VEH VEHICLE or NON-MOTORIST	Driver Full Name Michael G Pruitt II		Street Address [REDACTED]				City and State Mt Juliet TN		ZIP 37122	Telephone [REDACTED]	
	DOB Month Day Year [REDACTED]	Race 1	Sex 1	DL State TN	Driver License No. [REDACTED]		DL Class A	DL Status C	Restrict Violations 97	CDL Status C	Endorse Violations 97
	Place of Employment Masters Landscape Design (Mt. Juliet, TN)								Residence Less Than 25 Miles No		
	Liability Insurance Co. Selective Insurance Company						Liability Policy No. [REDACTED]		Insurance NAIC Number Unk		
	Driver Condition 1	Sobriety/ Officer Opinion 1	Alcohol: No Drugs: No	Type Alcohol Test Given 1	Alcohol Test Results Unk	Type Drug Test Given 1	Drug Test Results 99	Maneuver 15			
	Most Harmful Event for MV 22	Travel Road Name I-65			Road Code I065	Travel Direction 1	Unit Contributing Circumstance 97	Total Injuries in Unit 4			
	Sequence of Events 22	Event 1 22	Event 2 22	Event 3 11	Event 4 97	First Harmful Event Location 1		Areas Damaged Are Shaded			
	Veh Year 2019	Make FORD	Veh Model F-150		Body 2	V.I.N. 1FTEW1E53KFC [REDACTED]		14 Under Carriage			
	Owner's Name Master's Landscape Design				License Tag Number [REDACTED]	State TN	Year 2021	11 12 13 14 15 16 17 18 19 20 21 22 23 24 25 26 27 28 29 30 31 32 33 34 35 36 37 38 39 40 41 42 43 44 45 46 47 48 49 50 51 52 53 54 55 56 57 58 59 60 61 62 63 64 65 66 67 68 69 70 71 72 73 74 75 76 77 78 79 80 81 82 83 84 85 86 87 88 89 90 91 92 93 94 95 96 97 98 99 00			

10 UNIT NO LEFT SCENE COM VEH VEHICLE or NON-MOTORIST	Driver Full Name JAMES EARL MAYS		Street Address [REDACTED]				City and State VERBENA AL		ZIP 36091	Telephone [REDACTED]	
	DOB Month Day Year [REDACTED]	Race 2	Sex 1	DL State AL	Driver License No. [REDACTED]		DL Class DM	DL Status C	Restrict Violations 97	CDL Status 97	Endorse Violations 97
	Place of Employment Retired								Residence Less Than 25 Miles No		
	Liability Insurance Co. State Farm						Liability Policy No. [REDACTED]		Insurance NAIC Number		
	Driver Condition 1	Sobriety/ Officer Opinion 1	Alcohol: No Drugs: No	Type Alcohol Test Given 6	Alcohol Test Results N/A	Type Drug Test Given 4	Drug Test Results 97	Maneuver 15			
	Most Harmful Event for MV 22	Travel Road Name I-65			Road Code I065	Travel Direction 1	Unit Contributing Circumstance 97	Total Injuries in Unit 2			
	Sequence of Events 22	Event 1 22	Event 2 22	Event 3 3	Event 4 97	First Harmful Event Location 1		Areas Damaged Are Shaded			
	Veh Year 2016	Make DODG	Veh Model RAM 1500 4X4 CREW LONGHOR		Body 2	V.I.N. 1C6RR7PT9GS [REDACTED]		14 Under Carriage			
	Owner's Name Same				License Tag Number [REDACTED]	State AL	Year 2021	11 12 13 14 15 16 17 18 19 20 21 22 23 24 25 26 27 28 29 30 31 32 33 34 35 36 37 38 39 40 41 42 43 44 45 46 47 48 49 50 51 52 53 54 55 56 57 58 59 60 61 62 63 64 65 66 67 68 69 70 71 72 73 74 75 76 77 78 79 80 81 82 83 84 85 86 87 88 89 90 91 92 93 94 95 96 97 98 99 00			

Seating Position Codes

2, 4, or 6 Passenger	9 Passenger (add):	12 Passenger (add):	Bicycle, Motorcycle, ATV	12 - Pedestrian	16 - Not in Passenger Compartment
1 2 3	7 8 9	17 18 19	10	13 - Rider of Domestic Animal	97 - Not Applicable
4 5 6			11	14 - Occ. of Non-Motorized Vehicle	98 - Other (Explain)
				15 - Passenger of Bus	99 - Unknown

UNINJURED OCCUPANTS

Unit No	Seat Pos	Occ. Type	Safety Equip.	Air-bag	Age Code	Sex	Ejec-tion	Birth Date	Unit No	Seat Pos	Occ. Type	Safety Equip.	Air-bag	Age Code	Sex	Ejec-tion	Birth Date
5	1	1	2	99	8	2	1	[REDACTED]	5	3	2	2	99	5	2	1	[REDACTED]
5	5	2	5	1	1	1	1	[REDACTED]	5	7	2	2	99	4	1	1	[REDACTED]
5	8	2	2	1	5	2	1	[REDACTED]	5	9	2	2	99	3	1	1	[REDACTED]
5	17	2	2	99	6	2	1	[REDACTED]	5	18	2	2	1	6	2	1	[REDACTED]
5	19	2	2	99	6	2	1	[REDACTED]	8	1	1	2	14	8	1	1	[REDACTED]

VICTIMS

	N/A <input type="checkbox"/>	Unit No	Seat Pos	Occ. Type	Safety Equip.	Air-bag	Injury Type	Age	Sex	Ejection	First Aid By
Name Steven Ray Lenga		6	1	1	2	14	3	8	1	1	1
Address [REDACTED]											
Taken To Jackson Hospital						Taken By Haynes Ambulance					
Medical Facility EMS ground							Birth Date [REDACTED]				
Name JAMES RAFE WHITED		7	1	1	2	2	3	8	1	1	1
Address [REDACTED]											
Taken To Regional Medical Center						Taken By POV					
Medical Facility Private vehicle							Birth Date [REDACTED]				
Name MALANA MOORE WHITED		7	3	2	2	2	4	8	2	1	97
Address [REDACTED]											
Taken To Regional Medical Center						Taken By POV					
Medical Facility Private vehicle							Birth Date [REDACTED]				
Name [REDACTED]		7	4	2	5	2	3	2	1	1	1
Address [REDACTED]											
Taken To Baptist South						Taken By 99					
Medical Facility EMS ground							Birth Date [REDACTED]				
Name [REDACTED]		7	5	2	7	1	3	3	1	1	1
Address [REDACTED]											
Taken To Baptist South						Taken By 99					
Medical Facility EMS ground							Birth Date [REDACTED]				
Name KATELIN NICOLE WHITED		7	6	2	2	2	3	8	2	1	1
Address [REDACTED]											
Taken To Jackson Hospital						Taken By 99					
Medical Facility EMS ground							Birth Date [REDACTED]				
Name Michael G Pruitt II		9	1	1	2	99	4	8	1	1	1
Address [REDACTED]											
Taken To Regional Medical Center						Taken By POV					
Medical Facility Private vehicle							Birth Date [REDACTED]				
Name Donna Michelle Pruitt		9	3	2	2	99	4	8	2	1	1
Address [REDACTED]											
Taken To Regional Medical Center						Taken By POV					
Medical Facility Private vehicle							Birth Date [REDACTED]				
Name [REDACTED]		9	4	2	2	99	4	5	1	1	1
Address [REDACTED]											
Taken To Regional Medical Center						Taken By POV					
Medical Facility Private vehicle							Birth Date [REDACTED]				

VICTIMS

	N/A <input type="checkbox"/>	Unit No	Seat Pos	Occ. Type	Safety Equip.	Air-bag	Injury Type	Age	Sex	Ejection	First Aid By
Name [REDACTED]		9	6	2	2	99	4	5	1	1	1
Address [REDACTED]											
Taken To Regional Medical Center						Taken By POV					
Medical Facility Private vehicle						Birth Date [REDACTED]					
Name JAMES EARL MAYS		10	1	1	2	99	4	8	1	1	1
[REDACTED]											
Taken To Baptist South						Taken By 99					
Medical Facility EMS ground						B [REDACTED]					
Name DOROTHY JOHNSON MAYS		10	3	2	2	99	4	9	2	1	1
Address [REDACTED]											
Taken To Baptist South						Taken By 99					
Medical Facility EMS ground						Birth Date [REDACTED]					

DIAGRAM

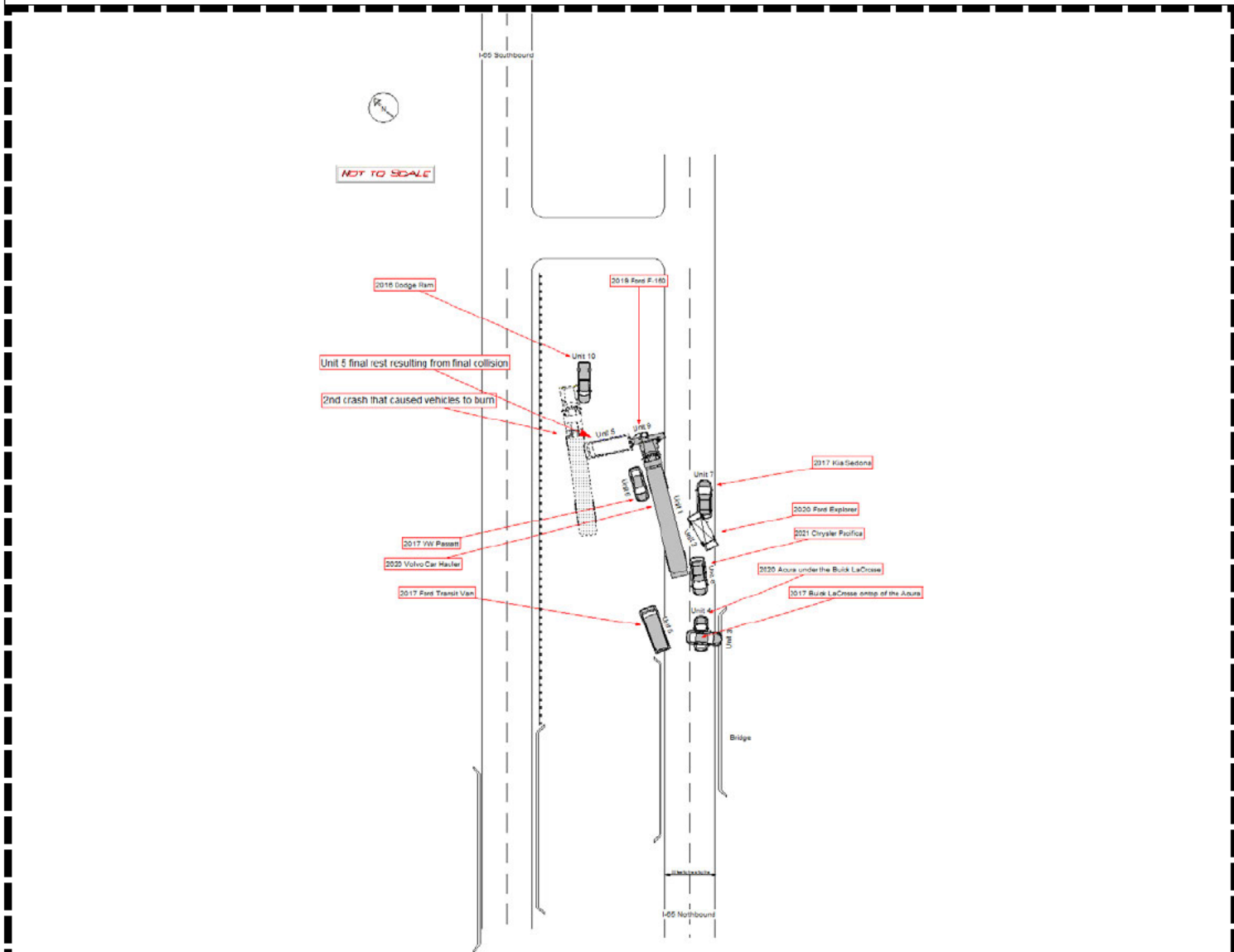

NARRATIVE

All units were travelling northbound on I-65. Unit 1 was traveling in the right lane too fast for conditions just ahead of and next to unit 5. Unit 1 was traveling at 70 miles per hour in the rain with reduced visibility. Unit 1 collided into the rear of unit 2 that had just stopped after colliding with unit 3. Unit 1 then traveled left colliding with unit 5 on the side (side swipe) and then colliding into the rear of unit 6 and unit 7. Unit 1 continued, striking the concrete bridge railing and

NARRATIVE

vehicles, involving units 4, 8, 9 and 10 before ultimately coming to final rest in the grass median just north of the bridge. Units 5 and 10 came to rest in the grass median. Unit 9 was caught in the front of unit 1 which resulted in Unit 9 being pushed into the grass median where it came to a final rest on its driver side in front of unit 1. Unit 6 driver was attempting to pull as far left as possible to avoid collisions.

Prior to this crash, a single-vehicle crash occurred at approximately 2:17 p.m. on the bridge at the same location on Interstate 65 at the 138.3-mile marker, which involved a 2019 Hyundai Santa Fe, with a vehicle identification number (VIN) of 5NMS33AD4KH085821. This single-vehicle collision forced the driver, Mark A. Willis, to pull over onto the grass median just beyond the bridge near the inside northbound lane. As a result of this one vehicle crash, multiple vehicles south of that crash began to slow and collect in both northbound lanes near the end of the bridge.

Subsequent crashes that followed, involving another tractor trailer, resulted in units 1, 5, 6, 9 and 10 to burn.

The driver and passenger of unit 10 were released from the hospital prior to making contact with any Trooper.

The diagram depicts the final rest of the vehicles.

Reference crashes: 1681934, 1681937, and 1681939 for all crashes reported at this scene on this date.

ROADWAY ENVIRONMENT

Unit No.	1	Involved Road/Bridge	1	Road Surface Type	2	Roadway Condition	2	Workzone Related?	1	Workzone Type	97	Workers Present?	NotApplicable	Workzone Law Enforcement Present?	97	Contributing Circumstances Environment	2	Contrib Matl In Roadway	1				
Contrib Material Source	97	Rdway Curve & Grade	1	Vision Obscured By	97	Traffic Control	1	Traffic Control Functioning	97	Opposing Lane Separation	6	Trafficway Lanes	4	Turn Lanes	1	One-Way Street	No	Total # Occupants In Unit	1	Total # Injured in Unit	1	Total # Killed in Unit	0
Total Number of Units		Light			Weather			Locale			Police Present?		DOT Railroad Crossing No.										
10		1			5			1			No		N/A										
Unit No.	2	Involved Road/Bridge	1	Road Surface Type	2	Roadway Condition	2	Workzone Related?	1	Workzone Type	97	Workers Present?	NotApplicable	Workzone Law Enforcement Present?	97	Contributing Circumstances Environment	2	Contrib Matl In Roadway	1				
Contrib Material Source	97	Rdway Curve & Grade	1	Vision Obscured By	97	Traffic Control	1	Traffic Control Functioning	97	Opposing Lane Separation	6	Trafficway Lanes	4	Turn Lanes	1	One-Way Street	No	Total # Occupants In Unit	4	Total # Injured in Unit	2	Total # Killed in Unit	2
Total Number of Units		Light			Weather			Locale			Police Present?		DOT Railroad Crossing No.										
10		1			5			1			No		N/A										
Unit No.	3	Involved Road/Bridge	1	Road Surface Type	2	Roadway Condition	2	Workzone Related?	1	Workzone Type	97	Workers Present?	NotApplicable	Workzone Law Enforcement Present?	97	Contributing Circumstances Environment	2	Contrib Matl In Roadway	1				
Contrib Material Source	97	Rdway Curve & Grade	1	Vision Obscured By	97	Traffic Control	1	Traffic Control Functioning	97	Opposing Lane Separation	6	Trafficway Lanes	4	Turn Lanes	1	One-Way Street	No	Total # Occupants In Unit	2	Total # Injured in Unit	2	Total # Killed in Unit	0
Total Number of Units		Light			Weather			Locale			Police Present?		DOT Railroad Crossing No.										
10		1			5			1			No		N/A										
Unit No.	4	Involved Road/Bridge	1	Road Surface Type	2	Roadway Condition	2	Workzone Related?	1	Workzone Type	97	Workers Present?	NotApplicable	Workzone Law Enforcement Present?	97	Contributing Circumstances Environment	2	Contrib Matl In Roadway	1				
Contrib Material Source	97	Rdway Curve & Grade	1	Vision Obscured By	97	Traffic Control	1	Traffic Control Functioning	97	Opposing Lane Separation	6	Trafficway Lanes	4	Turn Lanes	1	One-Way Street	No	Total # Occupants In Unit	2	Total # Injured in Unit	2	Total # Killed in Unit	0
Total Number of Units		Light			Weather			Locale			Police Present?		DOT Railroad Crossing No.										
10		1			5			1			No		N/A										
Unit No.	5	Involved Road/Bridge	1	Road Surface Type	2	Roadway Condition	2	Workzone Related?	1	Workzone Type	97	Workers Present?	NotApplicable	Workzone Law Enforcement Present?	97	Contributing Circumstances Environment	2	Contrib Matl In Roadway	1				
Contrib Material Source	97	Rdway Curve & Grade	1	Vision Obscured By	97	Traffic Control	1	Traffic Control Functioning	97	Opposing Lane Separation	6	Trafficway Lanes	4	Turn Lanes	1	One-Way Street	No	Total # Occupants In Unit	9	Total # Injured in Unit	0	Total # Killed in Unit	0
Total Number of Units		Light			Weather			Locale			Police Present?		DOT Railroad Crossing No.										
10		1			5			1			No		N/A										
Unit No.	6	Involved Road/Bridge	1	Road Surface Type	2	Roadway Condition	2	Workzone Related?	1	Workzone Type	97	Workers Present?	NotApplicable	Workzone Law Enforcement Present?	97	Contributing Circumstances Environment	2	Contrib Matl In Roadway	1				
Contrib Material Source	97	Rdway Curve & Grade	1	Vision Obscured By	97	Traffic Control	1	Traffic Control Functioning	97	Opposing Lane Separation	6	Trafficway Lanes	4	Turn Lanes	1	One-Way Street	No	Total # Occupants In Unit	1	Total # Injured in Unit	1	Total # Killed in Unit	0
Total Number of Units		Light			Weather			Locale			Police Present?		DOT Railroad Crossing No.										
10		1			5			1			No		N/A										
Unit No.	7	Involved Road/Bridge	1	Road Surface Type	2	Roadway Condition	2	Workzone Related?	1	Workzone Type	97	Workers Present?	NotApplicable	Workzone Law Enforcement Present?	97	Contributing Circumstances Environment	2	Contrib Matl In Roadway	1				
Contrib Material Source	97	Rdway Curve & Grade	1	Vision Obscured By	97	Traffic Control	1	Traffic Control Functioning	97	Opposing Lane Separation	6	Trafficway Lanes	4	Turn Lanes	1	One-Way Street	No	Total # Occupants In Unit	5	Total # Injured in Unit	5	Total # Killed in Unit	0
Total Number of Units		Light			Weather			Locale			Police Present?		DOT Railroad Crossing No.										
10		1			5			1			No		N/A										
Unit No.	8	Involved Road/Bridge	1	Road Surface Type	2	Roadway Condition	2	Workzone Related?	1	Workzone Type	97	Workers Present?	NotApplicable	Workzone Law Enforcement Present?	97	Contributing Circumstances Environment	2	Contrib Matl In Roadway	1				
Contrib Material Source	97	Rdway Curve & Grade	1	Vision Obscured By	97	Traffic Control	1	Traffic Control Functioning	97	Opposing Lane Separation	6	Trafficway Lanes	4	Turn Lanes	1	One-Way Street	No	Total # Occupants In Unit	5	Total # Injured in Unit	0	Total # Killed in Unit	0
Total Number of Units		Light			Weather			Locale			Police Present?		DOT Railroad Crossing No.										
10		1			5			1			No		N/A										

ROADWAY ENVIRONMENT

Unit No.	9	Involved Road/Bridge	1	Road Surface Type	2	Roadway Condition	2	Workzone Related?	1	Workzone Type	97	Workers Present?	NotApplicable	Workzone Law Enforcement Present?	97	Contributing Circumstances Environment	2	Contrib Matl In Roadway	1				
Contrib Material Source	97	Rdway Curve & Grade	1	Vision Obscured By	97	Traffic Control	1	Traffic Control Functioning	97	Opposing Lane Separation	6	Trafficway Lanes	4	Turn Lanes	1	One-Way Street	No	Total # Occupants In Unit	4	Total # Injured in Unit	4	Total # Killed in Unit	0
Total Number of Units		Light			Weather			Locale			Police Present?		DOT Railroad Crossing No.										
10		1			5			1			No		N/A										

Unit No.	10	Involved Road/Bridge	1	Road Surface Type	2	Roadway Condition	2	Workzone Related?	1	Workzone Type	97	Workers Present?	NotApplicable	Workzone Law Enforcement Present?	97	Contributing Circumstances Environment	2	Contrib Matl In Roadway	1				
Contrib Material Source	97	Rdway Curve & Grade	1	Vision Obscured By	97	Traffic Control	1	Traffic Control Functioning	97	Opposing Lane Separation	6	Trafficway Lanes	4	Turn Lanes	1	One-Way Street	No	Total # Occupants In Unit	2	Total # Injured in Unit	2	Total # Killed in Unit	0
Total Number of Units		Light			Weather			Locale			Police Present?		DOT Railroad Crossing No.										
10		1			5			1			No		N/A										

INVESTIGATION

Name of Photographer																							
Glenn L Furukawa																							
Time Police Notified			Time Police Arrived			Time EMS Arrived			EMS Response Run #														
1430 MT			1504 MT			1438 MT			N/A														
Name of Investigating Officer						Officer ID			Agency ORI														
Glenn L Furukawa						1019			ALDPS5500														
Name of Investigating Officer						Officer ID			Agency ORI														
Phillip A Faukner						1106			ALDPS5500														
The data on this report reflects the best knowledge, opinion, and belief regarding the crash, but no warrant is made as to the factual accuracy thereof.																							

ALABAMA UNIFORM TRAFFIC CRASH REPORT

Truck/Bus Supplemental Sheet

AST-27B Rev. 06/08

Unit No. 1
(same as on main report)

General Instructions																																				
<p><i>Complete this form each qualifying vehicle ONLY if the crash meets BOTH of the Following criteria:</i></p> <p>1. The crash involved a qualifying vehicle (a truck with a gross vehicle weight rating (GVWR) or a gross combination weight rating (GCWR) of more than 10,000 pounds, or Haz/Mat placard, or a vehicle designed to carry nine 9 or more, including driver) and;</p> <p>2. The crash resulted in at least one of the following: A. one or more fatalities B. one or more persons injured and taken from the scene for immediate medical attention, or C. one or more involved vehicles had to be towed from the scene as a result of disabling damage or had to receive assistance to leave.</p>																																				
Screening Information																																				
<p><i>Number of Qualifying Vehicles:</i></p> <p>Trucks with GVWR or GCWR of more than 10,000 pounds or Haz/Mat placard <u>1</u></p> <p>Buses designed to carry 9 or more (including driver) <u>1</u></p> <p style="text-align: center;">Number of vehicles towed from scene due to damage <u>9</u></p>	<p><i>Number of Persons:</i></p> <p>Sustaining fatal injuries <u>2</u></p> <p>Transported for immediate medical treatment <u>13</u></p>																																			
Vehicle Information																																				
<p><i>Weight Rating of Power Unit of the Truck</i></p> <p>3. - More than 26,000 pounds</p>	<p><i>Hazardous Material Involvement</i></p> <p>Did vehicle have a Haz/Mat placard? <input type="checkbox"/></p> <p>If Yes, include following information from placard</p> <p>A. Name or 4-digit number from Diamond or box _____</p> <p>B. The 1-digit number from bottom of diamond _____</p> <p>Was hazardous material released from THIS vehicle's cargo? <input type="checkbox"/></p>																																			
<p><i>Vehicle Configuration</i></p> <p>9. - Tractor with semi-trailer</p>	<p><i>Bus Usage</i></p> <p>1. - Not a bus</p>																																			
<p><i>Cargo Body Type</i></p> <p>8. - Auto transporter</p>	<p><i>Cargo Type</i></p> <p>1. - None</p>																																			
Motor Carrier Information																																				
<p>NOTE: If NOT a motor carrier, enter NONE under Carrier Name, 0 for None under Carrier Identification Numbers, and go to Sequence Of Events Section</p>																																				
<p><i>Carrier Name</i> <u>Hansen and Adkins Auto Transport LLC</u></p> <p><i>Carrier Phone</i> _____</p> <p><i>Carrier Mailing Address (Street or P.O. Box)</i> <u>3552 Green Avenue</u></p> <p><i>City, State, Zip</i> <u>Los Alamitos, CA 90720</u></p> <p style="text-align: right;">None = 0)</p> <p><i>Motor Carrier Type</i> <u>1. - Interstate carrier</u></p> <p><i>US DOT</i> <u>568253</u> <i>ICC MC</i> <u>277621</u> <i>STATE NO.</i> <u>N/A</u></p> <p><i>STATE</i> _____ <i>OTHER COUNTRY AUTHORITY</i> _____ <i>COUNTRY</i> <u>N/A</u></p>																																				
Sequence of Events																																				
<p>NOTE: for THIS vehicle -- list up to four</p> <table style="width: 100%; border-collapse: collapse;"> <tr> <td style="width: 25%; text-align: center;">Event #1</td> <td style="width: 25%; text-align: center;">Event #2</td> <td style="width: 25%; text-align: center;">Event #3</td> <td style="width: 25%; text-align: center;">Event #4</td> </tr> <tr> <td style="text-align: center;"><u>13</u></td> <td style="text-align: center;"><u>13</u></td> <td style="text-align: center;"><u>18</u></td> <td style="text-align: center;"><u>13</u></td> </tr> </table>		Event #1	Event #2	Event #3	Event #4	<u>13</u>	<u>13</u>	<u>18</u>	<u>13</u>																											
Event #1	Event #2	Event #3	Event #4																																	
<u>13</u>	<u>13</u>	<u>18</u>	<u>13</u>																																	
EVENT CODES	<table style="width: 100%; border-collapse: collapse;"> <tr> <td style="width: 25%;">Non-Collision</td> <td style="width: 25%;">1. Ran off road</td> <td style="width: 25%;">2. Jackknife</td> <td style="width: 25%;">3. Overturned (rollover)</td> <td style="width: 25%;">4. Downhill runaway</td> </tr> <tr> <td>Collision with</td> <td>5. Cargo loss or shift</td> <td>6. Explosion or fire</td> <td>7. Separation of units</td> <td>8. Cross median/centerline</td> </tr> <tr> <td></td> <td>9. Equipment Failure (brake failure, blown tires, etc.)</td> <td>10. Other non-collision</td> <td>11. Unknown</td> <td></td> </tr> <tr> <td></td> <td>12. Pedestrian</td> <td>13. Motor Vehicle in Transport</td> <td>14. Parked Motor Vehicle</td> <td>15. Train</td> </tr> <tr> <td></td> <td>16. Pedalcycle</td> <td>17. Animal</td> <td>18. Fixed object</td> <td>19. Work Zone Maintenance equipment</td> </tr> <tr> <td></td> <td>20. Other movable object</td> <td>21. Unknown movable object</td> <td></td> <td></td> </tr> <tr> <td></td> <td>Not applicable</td> <td>97. Not applicable</td> <td></td> <td></td> </tr> </table>	Non-Collision	1. Ran off road	2. Jackknife	3. Overturned (rollover)	4. Downhill runaway	Collision with	5. Cargo loss or shift	6. Explosion or fire	7. Separation of units	8. Cross median/centerline		9. Equipment Failure (brake failure, blown tires, etc.)	10. Other non-collision	11. Unknown			12. Pedestrian	13. Motor Vehicle in Transport	14. Parked Motor Vehicle	15. Train		16. Pedalcycle	17. Animal	18. Fixed object	19. Work Zone Maintenance equipment		20. Other movable object	21. Unknown movable object				Not applicable	97. Not applicable		
Non-Collision	1. Ran off road	2. Jackknife	3. Overturned (rollover)	4. Downhill runaway																																
Collision with	5. Cargo loss or shift	6. Explosion or fire	7. Separation of units	8. Cross median/centerline																																
	9. Equipment Failure (brake failure, blown tires, etc.)	10. Other non-collision	11. Unknown																																	
	12. Pedestrian	13. Motor Vehicle in Transport	14. Parked Motor Vehicle	15. Train																																
	16. Pedalcycle	17. Animal	18. Fixed object	19. Work Zone Maintenance equipment																																
	20. Other movable object	21. Unknown movable object																																		
	Not applicable	97. Not applicable																																		

ALABAMA UNIFORM TRAFFIC CRASH REPORT

Truck/Bus Supplemental Sheet



Unit No. 5
(same as on main report)



General Instructions																																				
<p><i>Complete this form each qualifying vehicle ONLY if the crash meets BOTH of the Following criteria:</i></p> <p>1. The crash involved a qualifying vehicle (a truck with a gross vehicle weight rating (GVWR) or a gross combination weight rating (GCWR) of more than 10,000 pounds, or Haz/Mat placard, or a vehicle designed to carry nine 9 or more, including driver) and;</p> <p>2. The crash resulted in at least one of the following: A. one or more fatalities B. one or more persons injured and taken from the scene for immediate medical attention, or C. one or more involved vehicles had to be towed from the scene as a result of disabling damage or had to receive assistance to leave.</p>																																				
Screening Information																																				
<p><i>Number of Qualifying Vehicles:</i></p> <p>Trucks with GVWR or GCWR of more than 10,000 pounds or Haz/Mat placard <u>1</u></p> <p>Buses designed to carry 9 or more (including driver) <u>1</u></p> <p style="text-align: right;">Number of vehicles towed from scene due to damage <u>9</u></p>	<p><i>Number of Persons:</i></p> <p>Sustaining fatal injuries <u>2</u></p> <p>Transported for immediate medical treatment <u>13</u></p>																																			
Vehicle Information																																				
<p><i>Weight Rating of Power Unit of the Truck</i></p> <p>1. - Less than or equal to 10,000 pounds</p>	<p><i>Hazardous Material Involvement</i></p> <p>Did vehicle have a Haz/Mat placard? <input type="checkbox"/></p> <p>If Yes, include following information from placard</p> <p>A. Name or 4-digit number from Diamond or box _____</p> <p>B. The 1-digit number from bottom of diamond _____</p> <p>Was hazardous material released from THIS vehicle's cargo? <input type="checkbox"/></p>																																			
<p><i>Vehicle Configuration</i></p> <p>3. - Bus (seats for 9 - 15 people, including driver)</p>	<p><i>Bus Usage</i></p> <p>98. - Other (explain in narrative)</p>																																			
<p><i>Cargo Body Type</i></p> <p>1. - Bus (9-15 passengers, including driver)</p>	<p><i>Cargo Type</i></p> <p>24. - Passenger</p>																																			
Motor Carrier Information																																				
<p>NOTE: If NOT a motor carrier, enter NONE under Carrier Name, 0 for None under Carrier Identification Numbers, and go to Sequence Of Events Section</p>																																				
<p>Carrier Name <u>Tallapoosa County Girls Ranch</u></p> <p>Carrier Phone _____</p> <p>Carrier Mailing Address (Street or P.O. Box) <u>174 Samford Drive</u></p> <p>City, State, Zip <u>Camp Hill, AL 36850</u></p> <p style="text-align: center;"><u>0</u> None = 0)</p> <p>Motor Carrier Type <u>2. - Intrastate carrier</u></p> <p>US DOT <u>Unk</u> ICC MC <u>Unk</u> STATE NO. <u>Unk</u></p> <p>STATE _____ OTHER COUNTRY AUTHORITY _____ COUNTRY <u>Unk</u></p>																																				
Sequence of Events																																				
<p>NOTE: for THIS vehicle -- list up to four</p> <table style="width: 100%; border-collapse: collapse;"> <tr> <td style="width: 25%;">Event #1</td> <td style="width: 25%; text-align: center;"><u>13</u></td> <td style="width: 25%;">Event #2</td> <td style="width: 25%; text-align: center;"><u>1</u></td> </tr> <tr> <td>Event #3</td> <td style="text-align: center;"><u>97</u></td> <td>Event #4</td> <td style="text-align: center;"><u>97</u></td> </tr> </table>		Event #1	<u>13</u>	Event #2	<u>1</u>	Event #3	<u>97</u>	Event #4	<u>97</u>																											
Event #1	<u>13</u>	Event #2	<u>1</u>																																	
Event #3	<u>97</u>	Event #4	<u>97</u>																																	
EVENT CODES	<table style="width: 100%; border-collapse: collapse;"> <tr> <td style="width: 15%;">Non-Collision</td> <td style="width: 15%;">1. Ran off road</td> <td style="width: 15%;">2. Jackknife</td> <td style="width: 15%;">3. Overturned (rollover)</td> <td style="width: 15%;">4. Downhill runaway</td> </tr> <tr> <td>Collision with</td> <td>5. Cargo loss or shift</td> <td>6. Explosion or fire</td> <td>7. Separation of units</td> <td>8. Cross median/centerline</td> </tr> <tr> <td></td> <td colspan="2">9. Equipment Failure (brake failure, blown tires, etc.)</td> <td>10. Other non-collision</td> <td>11. Unknown</td> </tr> <tr> <td></td> <td>12. Pedestrian</td> <td>13. Motor Vehicle in Transport</td> <td>14. Parked Motor Vehicle</td> <td>15. Train</td> </tr> <tr> <td></td> <td>16. Pedalcycle</td> <td>17. Animal</td> <td>18. Fixed object</td> <td>19. Work Zone Maintenance equipment</td> </tr> <tr> <td></td> <td>20. Other movable object</td> <td colspan="3">21. Unknown movable object</td> </tr> <tr> <td>Not applicable</td> <td colspan="4">97. Not applicable</td> </tr> </table>	Non-Collision	1. Ran off road	2. Jackknife	3. Overturned (rollover)	4. Downhill runaway	Collision with	5. Cargo loss or shift	6. Explosion or fire	7. Separation of units	8. Cross median/centerline		9. Equipment Failure (brake failure, blown tires, etc.)		10. Other non-collision	11. Unknown		12. Pedestrian	13. Motor Vehicle in Transport	14. Parked Motor Vehicle	15. Train		16. Pedalcycle	17. Animal	18. Fixed object	19. Work Zone Maintenance equipment		20. Other movable object	21. Unknown movable object			Not applicable	97. Not applicable			
Non-Collision	1. Ran off road	2. Jackknife	3. Overturned (rollover)	4. Downhill runaway																																
Collision with	5. Cargo loss or shift	6. Explosion or fire	7. Separation of units	8. Cross median/centerline																																
	9. Equipment Failure (brake failure, blown tires, etc.)		10. Other non-collision	11. Unknown																																
	12. Pedestrian	13. Motor Vehicle in Transport	14. Parked Motor Vehicle	15. Train																																
	16. Pedalcycle	17. Animal	18. Fixed object	19. Work Zone Maintenance equipment																																
	20. Other movable object	21. Unknown movable object																																		
Not applicable	97. Not applicable																																			

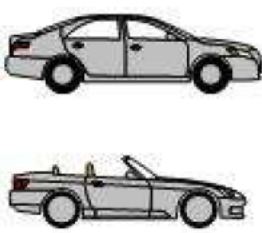
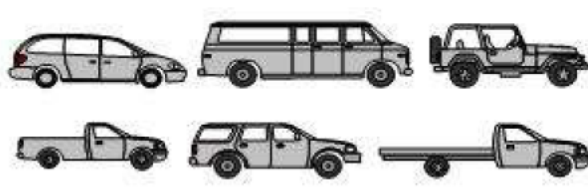
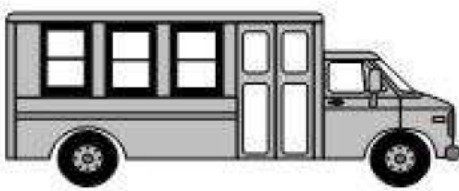

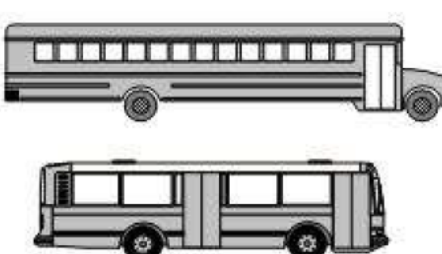
Definitions	
<p style="text-align: center;">Truck</p> <p>A motor vehicle designed, used or maintained primarily for the transportation of property. For the purpose of this form the vehicle must also meet one of the following criteria:</p> <ul style="list-style-type: none"> * Have a GVWR or a GCWR of more than 10,000 pounds, or * Carry a Hazardous Material Placard <p style="text-align: center;">Bus</p> <p>A motor vehicle providing seats for 9 or more persons including the driver and used primarily for the transportation of persons.</p> <p style="text-align: center;">Trailer</p> <p>A non-power vehicle towed by a motor vehicle.</p>	<p style="text-align: center;">Reportable Crash</p> <p>A highway related incident normally investigated by a police officer and reported on a standard crash report form involving one or more trucks or buses (as defined here) which results in:</p> <ul style="list-style-type: none"> * One or more fatalities, or * One or more non-fatal injuries requiring transportation for the purpose of obtaining immediate medical treatment, or * One or more of the vehicles being removed from the scene as a result of disabling damage, or * One or more of the vehicles requiring intervening assistance before proceeding under its own power.

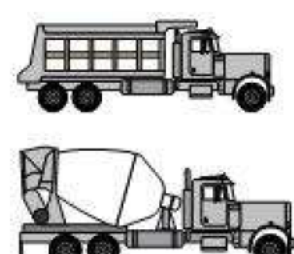
Typical Vehicle Silhouettes

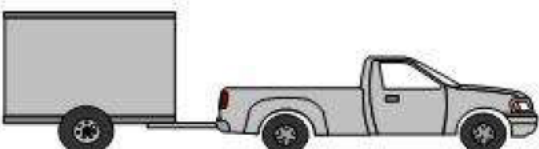
<p>1. Passenger Vehicle</p> 	<p>2. Light truck (van, mini-van, panel, pickup, sport utility vehicle)</p> 	<p>3. Bus (seats for 9-15 people, including driver)</p> 
--	---	---

<p>4. Bus (seats for more than 15 people, including driver)</p> 	<p>5. Single unit truck - 2 axles / 6 tires</p> 	<p>6. Single unit truck - 3 axles</p> 
--	--	--

<p>7. Truck with trailer</p> 	<p>8. Truck tractor (bobtail)</p> 	<p>9.</p> 
---	---	--

<p>10. Tractor with double trailers</p> 	<p>11. Tractor with triple trailers</p> 
--	--

Typical Hazardous Material Placards



LEGEND

Location	Category	Code	Description	Location	Category	Code	Description
Report Header	Unit Type	11	Tractor / semi-trailer	Driver	Liability Ins. Policy Code	0	Not Set
Report Header	Unit Type	6	Sport utility vehicle (SUV)	Driver	Liability Ins. Policy Code	99	Unknown
Location And Time	Contributing Circumstance	7	Driving too fast for conditions	Driver	Liability Insurance NAIC Number Code		Not Set
Location And Time	Contributing Unit	10	Unit1	Driver	Liability Insurance NAIC Number Code	Unk	Unknown
Location And Time	Controlled Access Highway Location	1	Main road	Driver	Maneuver	1	Movement essentially straight
Location And Time	Coordinate Status	Known	Known	Driver	Maneuver	15	Stopped in Traffic
Location And Time	Coordinate Type	1	From computerized map	Driver	Maneuver	98	Other (explain in narrative)
Location And Time	Crash Manner	7	Rear end (front-to-rear)	Driver	Phone Number Code	0	Not Set
Location And Time	Crash Severity	K	Fatal Injury	Driver	Place of Employment		Not Set
Location And Time	Distance Node Unit	20	Miles	Driver	Place of Employment	99	Unknown
Location And Time	Distracted Driving	97	Not applicable (not distracted)	Driver	Place of Employment	Retired	Retired
Location And Time	Harmful Event	22	Collision with vehicle in traffic	Driver	Race	1	White / Caucasian
Location And Time	Highway Classification	1	Interstate	Driver	Race	2	Black / African-American
Location And Time	Highway Side	1	Northbound	Driver	Residence Within 25 Miles	No	No
Location And Time	Roadway Feature	2	Bridge / overpass / underpass	Driver	Travel Direction	1	North
Location And Time	School Bus Related	1	No school bus involved	Vehicle	Attachment	1	None
Location And Time	Time Display Format	20	Military	Vehicle	Attachment	4	Other semi trailer
Driver	Alcohol Test Type	1	Blood test	Vehicle	Body	2	Four door
Driver	Alcohol Test Type	6	No Test Given	Vehicle	Body	4	Four door with rear entry
Driver	Commercial Driver License Status	97	Not applicable / unlicensed	Vehicle	Body	97	Not applicable - not passenger car, personal van, or SUV
Driver	Commercial Driver License Status	C	Current / valid	Vehicle	Body	98	Other (explain in narrative)
Driver	Contributing Circumstance	7	Driving too fast for conditions	Vehicle	Citation Offense	99	None
Driver	Contributing Circumstance	97	Not applicable	Vehicle	Damage Severity	3	Major, not disabled
Driver	Driver Address Code	0	Not Set	Vehicle	Damage Severity	4	Major, disabled
Driver	Driver Condition	1	Apparently normal	Vehicle	Defect	1	None
Driver	Driver Condition	6	Under the influence of alcohol / drugs	Vehicle	Emergency Status	97	Not applicable
Driver	Driver License Class Code	0	Not set	Vehicle	Estimated Speed Code		Not set
Driver	Driver License Endorsement	97	Not applicable	Vehicle	Estimated Speed Code	000	Stationary
Driver	Driver License Number	0	Not set	Vehicle	Hazardous Cargo	1	None
Driver	Driver License Restriction	97	Not applicable	Vehicle	Hazardous Cargo	97	Not applicable
Driver	Driver License State Code	0	Not set	Vehicle	Hazardous Cargo Release Type	97	Not applicable
Driver	Driver License Status	C	Current / valid	Vehicle	K12 Child Going To Or From School	0	Not Set
Driver	Driver Name Code	0	Not Set	Vehicle	Make	ACUR	Acura
Driver	Drug Test Result	97	Not applicable	Vehicle	Make	BUIC	Buick
Driver	Drug Test Result	99	Unknown	Vehicle	Make	CHRY	Chrysler
Driver	Drug Test Type	1	Blood test	Vehicle	Make	DODG	Dodge
Driver	Drug Test Type	4	No test given	Vehicle	Make	FORD	Ford
Driver	Gender	1	Male	Vehicle	Make	KIA	Kia Motors Corp.
Driver	Gender	2	Female	Vehicle	Make	VOLK	Volkswagen
Driver	Harmful Event	22	Collision with vehicle in traffic	Vehicle	Make	VOLV	

LEGEND

Location	Category	Code	Description	Location	Category	Code	Description
Vehicle	Non-Motorist Action	0	Not Set	Uninjured Occupants	Birth Date Code	0	Not Set
Vehicle	Non-Motorist Location	0	Not Set	Uninjured Occupants	Ejection Status	1	Not ejected or trapped
Vehicle	Oversized Load	N/A	NotApplicable	Uninjured Occupants	Gender	1	Male
Vehicle	Oversized Load	No	No	Uninjured Occupants	Gender	2	Female
Vehicle	Oversized Load Permit	N/A	NotApplicable	Uninjured Occupants	Occupant Type	1	Driver
Vehicle	Owner Address Code	0	Not Set	Uninjured Occupants	Occupant Type	2	Passenger
Vehicle	Owner Address Code	Same	Same	Uninjured Occupants	Safety Equipment	2	Shoulder and lap belt used
Vehicle	Owner Name Code		Not Set	Uninjured Occupants	Safety Equipment	5	Forward facing child safety seat used properly
Vehicle	Owner Name Code	Same	Same as driver	Victims	Age Code	1	0 - 3
Vehicle	Placard Requirement	2	No	Victims	Age Code	2	4 - 5
Vehicle	Placard Requirement	97	Not applicable	Victims	Age Code	3	6 - 8
Vehicle	Placard Status	3	Not applicable (placard not required)	Victims	Age Code	5	13 - 15
Vehicle	Tag Number		Not set	Victims	Age Code	8	26 - 64
Vehicle	Tag State	0	Not set	Victims	Age Code	9	65 or older
Vehicle	Tag Year	0	Not set	Victims	Airbag	1	Not installed
Vehicle	Tow Status	1	Towed due to disabling damage	Victims	Airbag	14	Deployed multiple combinations (all cases)
Vehicle	Tow Status	3	Not towed	Victims	Airbag	2	Not deployed, no switch
Vehicle	Towed Code	0	Not Set	Victims	Airbag	5	Deployed front, no switch
Vehicle	Towed Code	97	Not applicable	Victims	Airbag	8	Deployed side, no switch
Vehicle	Unit Type	1	Passenger car	Victims	Airbag	99	Unknown
Vehicle	Unit Type	11	Tractor / semi-trailer	Victims	Birth Date Code	0	Not Set
Vehicle	Unit Type	27	Small bus (seats 9-15, including driver)	Victims	Ejection Status	1	Not ejected or trapped
Vehicle	Unit Type	3	Pick-up	Victims	Ejection Status	2	Partially ejected
Vehicle	Unit Type	33	Mini-van	Victims	Ejection Status	4	Trapped within vehicle
Vehicle	Unit Type	6	Sport utility vehicle (SUV)	Victims	First Aid Provider	1	Paramedic / EMT
Vehicle	Usage	1	Personal vehicle	Victims	First Aid Provider	97	None - no first aid
Vehicle	Usage	30	Other bus (explain in narrative)	Victims	Gender	1	Male
Vehicle	Usage	6	Cargo Transportation	Victims	Gender	2	Female
Vehicle	VIN	0	Not set	Victims	Injury Type	1	(K) Fatal
Vehicle	Year		Not set	Victims	Injury Type	2	(A) Suspected serious injury
Uninjured Occupants	Age Code	1	0 - 3	Victims	Injury Type	3	(B) Suspected minor injury
Uninjured Occupants	Age Code	2	4 - 5	Victims	Injury Type	4	(C) Possible injury
Uninjured Occupants	Age Code	3	6 - 8	Victims	Medical Facility Transport	2	EMS ground
Uninjured Occupants	Age Code	4	9 - 12	Victims	Medical Facility Transport	4	Private vehicle
Uninjured Occupants	Age Code	5	13 - 15	Victims	Medical Facility Transport	97	Not Applicable
Uninjured Occupants	Age Code	6	16 - 20	Victims	Occupant Type	1	Driver
Uninjured Occupants	Age Code	8	26 - 64	Victims	Occupant Type	2	Passenger
Uninjured Occupants	Airbag	1	Not installed	Victims	Safety Equipment	1	None used - motor vehicle occupant
Uninjured Occupants	Airbag	14	Deployed multiple combinations (all cases)	Victims	Safety Equipment	2	Shoulder and lap belt used
Uninjured Occupants	Airbag	99	Unknown	Victims	Safety Equipment	5	Forward facing child safety seat used properly

LEGEND

Location	Category	Code	Description	Location	Category	Code	Description
Victims	Safety Equipment	6	Rear facing child safety seat used properly	Truck/Bus Supplement	ICCMC Number Code	Unk	Unknown
Victims	Safety Equipment	7	Child booster seat used properly	Truck/Bus Supplement	Motor Carrier Type	1	Interstate carrier
Victims	Safety Equipment	99	Unknown	Truck/Bus Supplement	Motor Carrier Type	2	Intrastate carrier
Victims	Victim Taken By		Not Set	Truck/Bus Supplement	State Number Code	N/A	Not applicable
Victims	Victim Taken By	99	Unknown	Truck/Bus Supplement	State Number Code	Unk	Unknown
Victims	Victim Taken By	N/A	Not applicable	Truck/Bus Supplement	USDOT Number Code	0	Not Set
Victims	Victim Taken To		Not Set	Truck/Bus Supplement	USDOT Number Code	Unk	Unknown
Victims	Victim Taken To	N/A	Not applicable	Truck/Bus Supplement	Vehicle Configuration	3	Bus (seats for 9 - 15 people, including driver)
Roadway Environment	Environmental Contributing Circumstance	2	Weather	Truck/Bus Supplement	Vehicle Configuration	9	Tractor with semi-trailer
Roadway Environment	Light Condition	1	Daylight	Truck/Bus Supplement	Weight Rating	1	Less than or equal to 10,000 pounds
Roadway Environment	Locale	1	Open country	Truck/Bus Supplement	Weight Rating	3	More than 26,000 pounds
Roadway Environment	Opposing Lane Separation	6	Concrete barrier				
Roadway Environment	Road Bridge Condition	1	None apparent				
Roadway Environment	Road Surface Type	2	Concrete				
Roadway Environment	Roadway Condition	2	Wet				
Roadway Environment	Roadway Curvature And Grade	1	Straight, level				
Roadway Environment	Roadway Material	1	None				
Roadway Environment	Roadway Material Source	97	Not applicable				
Roadway Environment	Traffic Control	1	No controls present				
Roadway Environment	Traffic Control Status	97	Not applicable				
Roadway Environment	Trafficway Lane Count	4	Four lanes				
Roadway Environment	Turn Lane Presence	1	None				
Roadway Environment	Vision Obscuration	1	Not obscured				
Roadway Environment	Vision Obscuration	97	Not applicable				
Roadway Environment	Weather Condition	5	Rain				
Roadway Environment	Workzone Law Enforcement Presence	97	Not applicable				
Roadway Environment	Workzone Relationship	1	Not in / related to workzone				
Roadway Environment	Workzone Type	97	Not applicable				
Truck/Bus Supplement	Bus Usage	1	Not a bus				
Truck/Bus Supplement	Bus Usage	98	Other (explain in narrative)				
Truck/Bus Supplement	Cargo Body Type	1	Bus (9-15 passengers, including driver)				
Truck/Bus Supplement	Cargo Body Type	8	Auto transporter				
Truck/Bus Supplement	Cargo Type	1	None				
Truck/Bus Supplement	Cargo Type	24	Passenger				
Truck/Bus Supplement	Carrier Address Code	0	Not Set				
Truck/Bus Supplement	Carrier Name Code	0	Not Set				
Truck/Bus Supplement	Carrier Phone Code	0	Not Set				
Truck/Bus Supplement	Country Number Code	N/A	Not applicable				
Truck/Bus Supplement	Country Number Code	Unk	Unknown				
Truck/Bus Supplement	ICCMC Number Code	0	Not Set				