

## LOADING ARRANGEMENTS

\*Pilot or passenger center of gravity on adjustable seats positioned for average occupant. Numbers in parentheses indicate forward and aft limits of occupant center of gravity range.

\*\*Arm measured to the center of the areas shown.

- NOTES:
1. The usable fuel C.G. arm is located at station 48.0.
  2. The rear cabin wall (approximate station 108) or aft baggage wall (approximate station 124) can be used as convenient interior reference points for determining the location of baggage area fuselage stations.

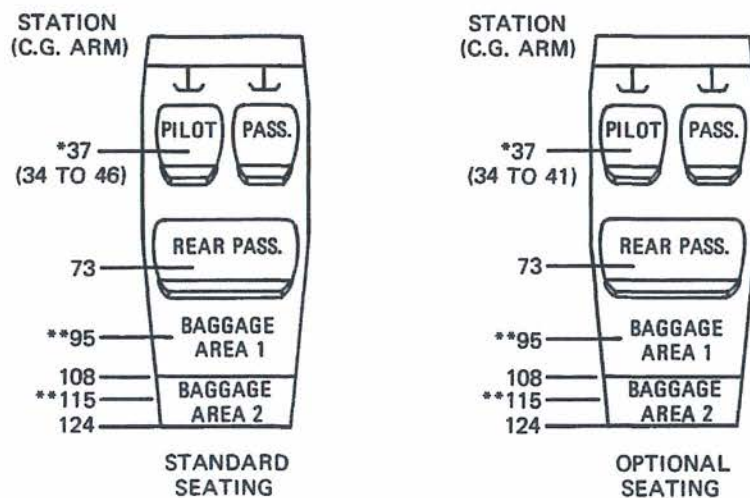
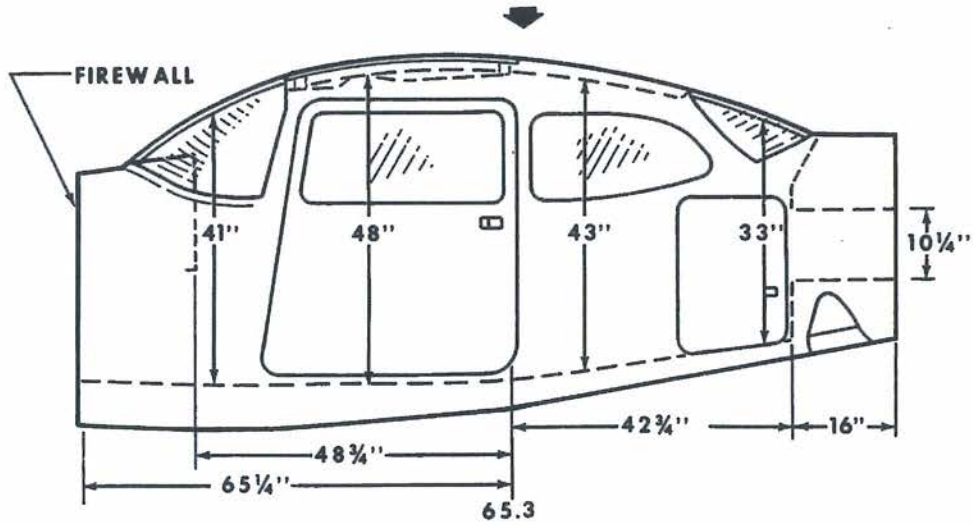

Figure 6-3. Loading Arrangements

**CABIN HEIGHT MEASUREMENTS**



**DOOR OPENING DIMENSIONS**

	WIDTH (TOP)	WIDTH (BOTTOM)	HEIGHT (FRONT)	HEIGHT (REAR)
CABIN DOOR	32"	37"	40"	41"
BAGGAGE DOOR	15 1/4"	15 1/4"	22"	21"

— WIDTH —  
● LWR WINDOW LINE  
\* CABIN FLOOR

**CABIN WIDTH MEASUREMENTS**

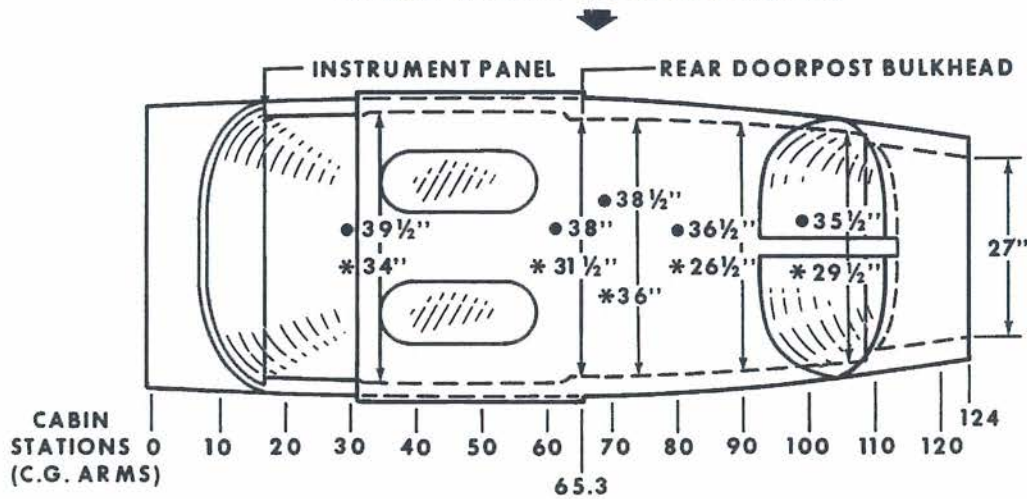
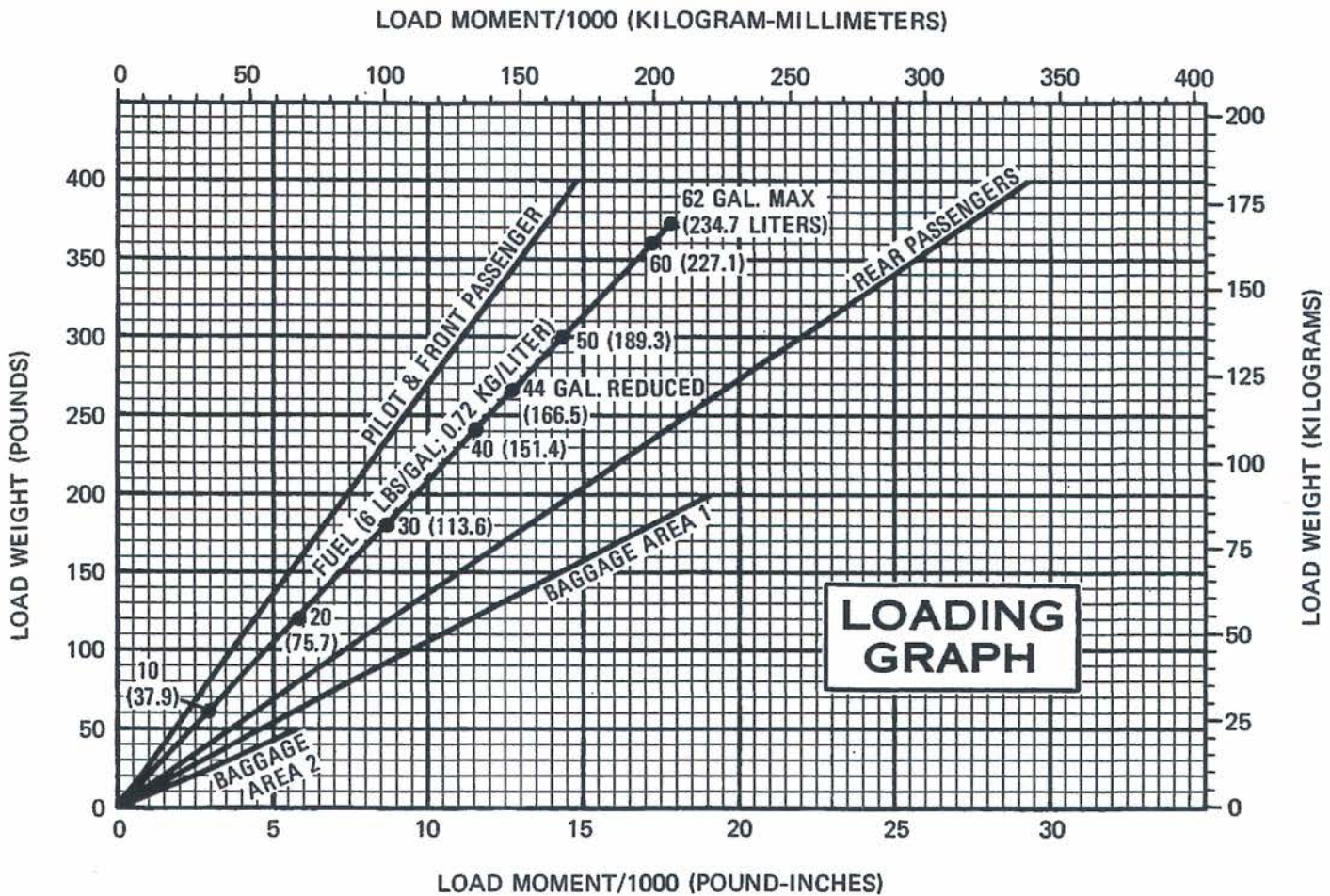

Figure 6-4. Internal Cabin Dimensions

SAMPLE LOADING PROBLEM	SAMPLE AIRPLANE		YOUR AIRPLANE	
	Weight (lbs.)	Moment (lb. -ins. /1000)	Weight (lbs.)	Moment (lb. - ins. /1000)
1. Basic Empty Weight (Use the data pertaining to your airplane as it is presently equipped. Includes unusable fuel and full oil) . . . . .	1624	61.6	1652.4	63.24
2. Usable Fuel (At 6 Lbs./Gal.) Standard Tanks (62 Gal. Maximum) . . . . .			372	17.75
Reduced Fuel (44 Gal.) . . . . .	264	12.7		
3. Pilot and Front Passenger (Station 34 to 46) . . . . .	340	12.6	314	11.5
4. Rear Passengers . . . . .	340	24.8	11	1.25
5. * Baggage Area 1 (Station 82 to 108 - 200 Lbs. Max.) . . . . .	90	8.6		
6. * Baggage Area 2 (Station 108 to 124 - 50 Lbs. Max.) . . . . .				
7. RAMP WEIGHT AND MOMENT	2658	120.3	2349.4	93.74
8. Fuel allowance for engine start, taxi, and runup	-8	-.4	-8	-.4
9. TAKEOFF WEIGHT AND MOMENT (Subtract Step 8 from Step 7)	2650	119.9	2341.4	93.34
10. Locate this point (2650 at 119.9) on the Center of Gravity Moment Envelope, and since this point falls within the envelope, the loading is acceptable. * The maximum allowable combined weight capacity for baggage areas 1 and 2 is 200 lbs.				

Figure 6-5. Sample Loading Problem



NOTES: Line representing adjustable seats shows the pilot or passenger center of gravity on adjustable seats positioned for an average occupant. Refer to the Loading Arrangements diagram for forward and aft limits of occupant C.G. range.

Figure 6-6. Loading Graph

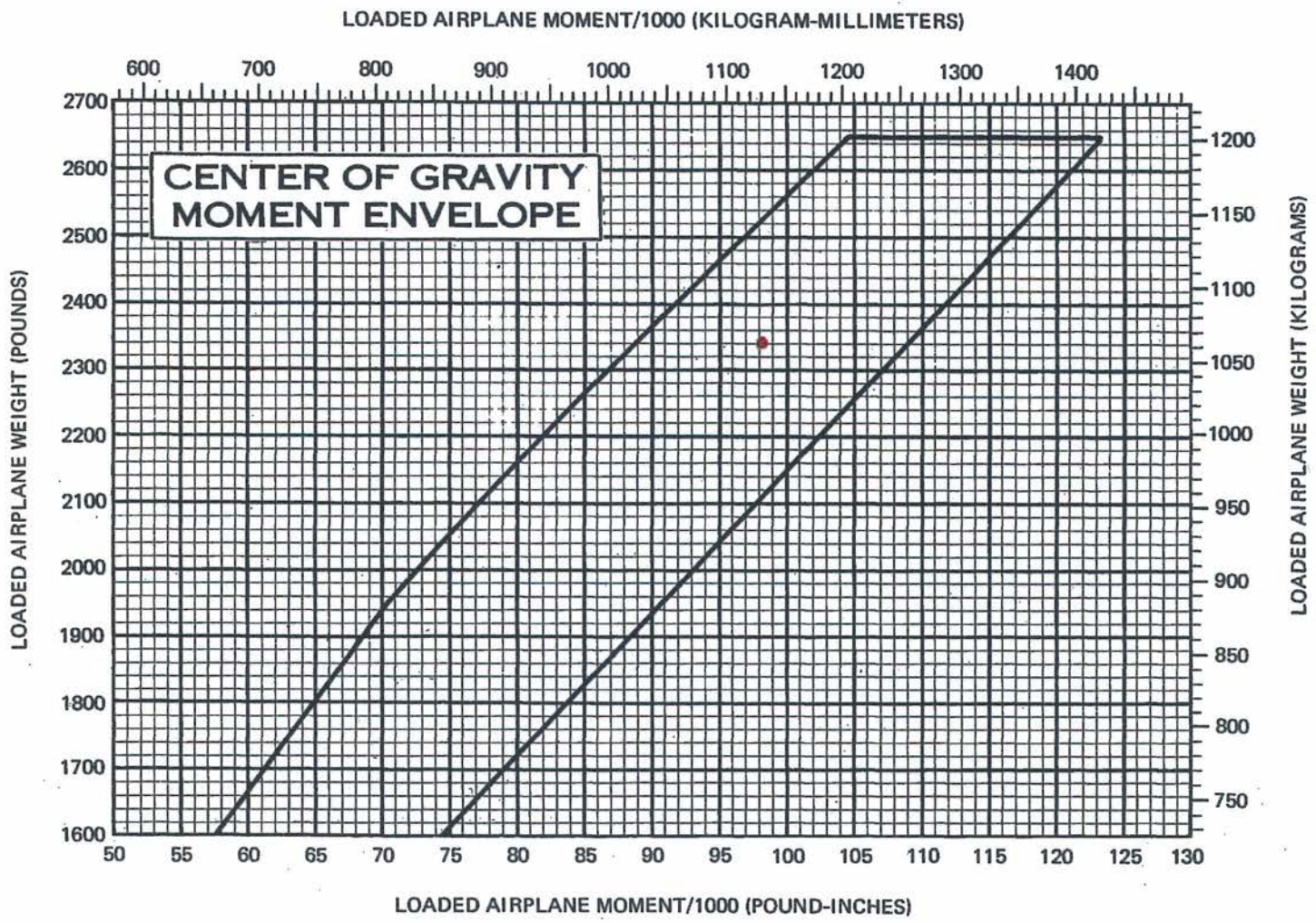

Figure 6-7. Center of Gravity Moment Envelope

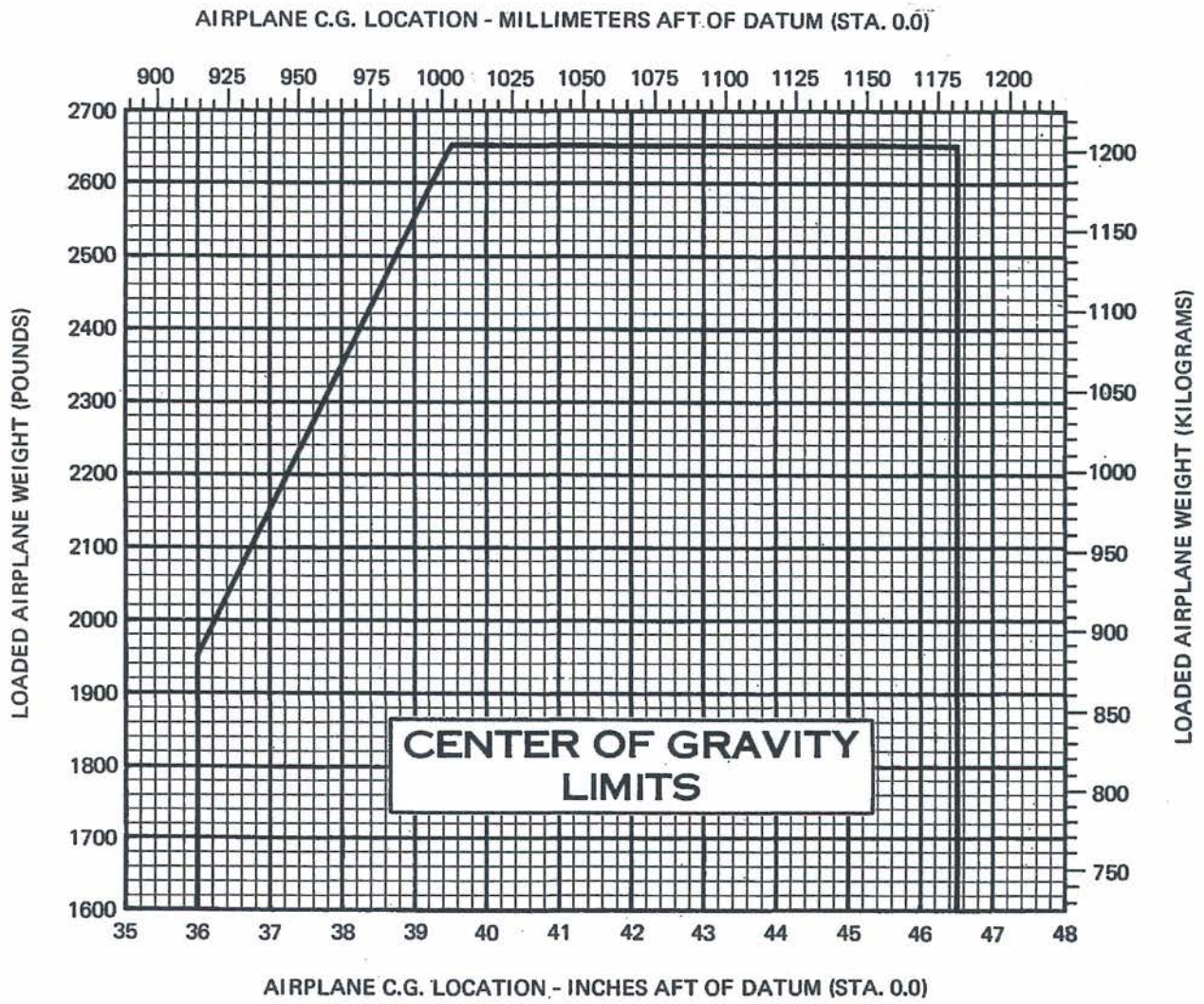

Figure 6-8. Center of Gravity Limits

# CESSNA AIRCRAFT COMPANY

WICHITA, KANSAS

## Weight & Balance and Installed Equipment Data

CONTROL NUMBER	DATE	MODEL	REGISTRATION NUMBER	CESSNA SERIAL NUMBER
005069	10/03/79	CUTLASS RG 11 WITH NAV-PAC	N6091R	172RG0079

ITEM	WEIGHT	ARM	MOMENT
STANDARD AIRPLANE (EMPTY, DRY) INCLUDING ALL REQUIRED AND STANDARD EQUIPMENT ITEMS	COMPUTED 1514.0	38.4	58138
UNUSABLE FUEL 4.0 GALLONS	24.0	46.0	1104
FULL OIL 9.0 QUARTS	16.9	16.1	272
STANDARD EMPTY WEIGHT	1554.9	37.9	58970
OPTIONAL EQUIPMENT REPLACING OR IN ADDITION TO REQUIRED AND STANDARD EQUIPMENT ITEMS			
-F- 580F BENGAL YELLOW-MAJOR	NEGL.		
-E- 580E BUTTERSCOTCH-ACCENT	NEGL.		
AF OPT-1 TAN VINYL W/KENYA FAB INSERTS	NEGL.		
BLACK UPPER INSTRUMENT PANEL	NEGL.		
BASIC AVIONICS KIT	5.8	55.6	322
300 M/C RT385A 720 COM 200 NAV VOR/LOC	8.3	11.9	99
300 ADF W/BFO R546E	8.0	19.9	159
300 TRANSPONDER RT399A LOW ALTITUDE DETECTORS, NAVIGATION LIGHTS	4.0	25.8	103
FLIGHT CONTROLS, DUAL	NEGL.		
HEATING SYSTEM, STALL WARNING & PITOT (EXCH.)	4.9	12.4	61
INDICATOR, TRUE AIRSPEED (EXCH.)	.6	24.4	15
LIGHT, BEACON, OMNI-FLASH	.1	15.1	2
LIGHTS, COURTESY	1.4	204.7	287
LOCATOR BEACON	.5	61.0	31
STATIC SOURCE, ALTERNATE	3.5	116.5	408
COM ANTENNA AND NAV COUPLER	.2	15.5	3
300 M/C RT385A VOR/LOC (2ND UNIT)	1.0	25.0	25
400 GLIDESLOPE R443B 40 CH. INCL. VOR/ILS (EXCH.)	8.3	11.9	99
400 MARKER BEACON R402A	5.9	105.6	623
BATTERY, 24-VOLT, HEAVY DUTY (EXCH.)	2.3	34.5	79
CLOCK DIGITAL (EXCH.)	2.0	130.0	260
GROUND SERVICE PLUG RECEPTACLE	NEGL.		
INDICATOR, ECONOMY MIXTURE	2.7	126.0	340
LIGHTS, INSTRUMENT POST	.6	7.8	5
LIGHTS, STROBE	.5	17.3	9
VALVE, OIL QUICK DRAIN	3.4	43.3	147
STATIC KIT, ANTI-PRECIPITATION	NEGL.		
RECORDER, FLIGHT HOUR	.4	143.2	57
SEAT PILOTS ARTICULATING RECLINE VERT. ADJ. (EXCH.)	.5	6.3	3
SEAT, FRONT PASSENGER ARTIC RECLINE & VERT ADJ EX.	10.4	38.5	400
VENTILATION SYSTEM, REAR SEAT	10.4	38.5	400
WINDOWS, TINTED ALL AROUND (EXCH.)	1.7	50.9	87
WINDOW, HINGED RH	NEGL.		
ONE 190	2.3	47.0	108
300 VOR/LOC IND. W/AUTOMATIC RADIAL CENTERING (EX)	7.5	18.9	139
300 VOR/ILS IND. W/AUTOMATIC RADIAL CENTERING (EX)	.2	14.7	3
	.1	14.7	1
BASIC EMPTY WEIGHT	1652.4	39.3	63245

SAMPLE LOADING PROBLEM	SAMPLE AIRPLANE		YOUR AIRPLANE	
	Weight (lbs.)	Moment (lb. -ins. /1000)	Weight (lbs.)	Moment (lb. - ins. /1000)
1. Basic Empty Weight (Use the data pertaining to your airplane as it is presently equipped. Includes unusable fuel and full oil) . . . . .	1624	61.6		
2. Usable Fuel (At 6 Lbs./Gal.) Standard Tanks (62 Gal. Maximum) . . . . .				
Reduced Fuel (44 Gal.) . . . . .	264	12.7		
3. Pilot and Front Passenger (Station 34 to 46) . . . . .	340	12.6		
4. Rear Passengers . . . . .	340	24.8		
5. * Baggage Area 1 (Station 82 to 108 - 200 Lbs. Max.) . . . . .	90	8.6		
6. * Baggage Area 2 (Station 108 to 124 - 50 Lbs. Max.) . . . . .				
7. RAMP WEIGHT AND MOMENT	2658	120.3		
8. Fuel allowance for engine start, taxi, and runup	-8	-.4		
9. TAKEOFF WEIGHT AND MOMENT (Subtract Step 8 from Step 7)	2650	119.9		
10. Locate this point (2650 at 119.9) on the Center of Gravity Moment Envelope, and since this point falls within the envelope, the loading is acceptable.  * The maximum allowable combined weight capacity for baggage areas 1 and 2 is 200 lbs.				

Figure 6-5. Sample Loading Problem