

VAN'S AIRCRAFT, INC.

14401 NE Keil Road, Aurora, Oregon, USA 97002

PHONE 503-678-6545 • FAX 503-678-6560 • [www.vansaircraft.com](http://www.vansaircraft.com) • [info@vansaircraft.com](mailto:info@vansaircraft.com)

---

Service Bulletin 07-11-09  
**Mandatory Service Bulletin**

**Date:** November 9, 2007

**Subject:** Nose gear leg and fork upgrade

**Affected Models:** All two-place, tricycle gear RV models  
(Finish Kits shipped prior to February, 2005)

**Required Action:** Upgrade nose gear leg and fork to current configuration

**Time of Compliance:** At or before the next annual condition inspection

**Synopsis:**

Data from the field, and the results of NTSB Structures Study (Case No.ANC05LA123 dated June 21, 2007), suggest that increased nose fork axle-to-ground clearance may reduce the likelihood of fork axle-to-runway surface contact during nose gear overload conditions. The nose gear leg/fork combination supplied in two-place tricycle gear RV kits after February, 2005 provides this increased clearance. Complying with this service bulletin will give aircraft shipped prior to that date the same, increased clearance.

*Nose gear legs and forks shipped after February, 2005 are not affected by this service bulletin.*

**Method of Compliance:**

In order to upgrade to the required configuration, affected nose gear legs must be either replaced or modified. In either case, the fork must be replaced.

1. Nose gear legs U-603, U-603-1 and their associated forks must be replaced with U-603-3 leg and WD-630-1 fork.
2. Gear legs (part no. U-603-2 and U-809-1) that are serviceable can either be replaced or modified and returned to service. In either case, the nose gear fork must be replaced.

Refer to page 3 (nose gear leg identification) to determine which nose gear leg is currently installed on your aircraft. Use the appropriate Replacement and Modification Procedure listed below for your particular nose gear leg.

## Replacement and Modification Procedures:

- **U-603, U-603-1** (Both leg and fork must be replaced.)  
[Finish Kits shipped prior to November 1, 1998]
  - a. Purchase a new nose fork from Van's Aircraft. Part no. WD-630-1
  - b. Purchase a new stop flange from Van's Aircraft. Part no. WD-631-PC
  - c. Purchase a new nose gear leg from Van's Aircraft. Part no. U-603-3X. At the time of purchase, ship your old gear leg to Van's Aircraft for 'match drilling'. Van's will duplicate the hole in your original gear leg to facilitate installation in the original engine mount.
  
- **U-603-2 and U-809-1** (Leg may be modified or replaced, fork must be replaced)  
[Finish Kits or replacement nose gear legs shipped between November 1, 1998 and February 5, 2005]
  - a. Purchase a new nose fork from Van's Aircraft. Part no. WD-630-1
  - b. If modifying the existing leg: Contact Langair Machining for shipping instructions and costs. The leg will be shipped directly to Langair Machining where it will be shortened, rethreaded and returned to the owner.
  - d. If replacing the existing leg: Purchase a new gear leg from Van's Aircraft. Part no. U-603-3X (RV-6A, 7A, 9A) or U-809-2X (RV-8A). At the time of purchase, ship your old gear leg to Van's Aircraft for 'match drilling'. Van's will duplicate the hole in your original gear leg to facilitate installation in the original engine mount.

Langair Machining  
33094 Church Road  
Warren, OR 97053  
(503) 397-1478  
www.langair.com

Van's Aircraft  
14401 NE Keil Rd.  
Aurora, OR 97002  
(503) 678-6545  
www.vansaircraft.com

# **NOSE GEAR LEG IDENTIFICATION PROCEDURE**

## **Step 1: (RV-6A Only)**

Measure Nose Gear Leg diameter as shown in Figure 2.

If: Diameter measures 1.000,

Then: Nose Gear Leg is part number U-603 or U-603-1.

Action: Nose Gear Leg and Nose Wheel Fork must be replaced.

If: Diameter measures 1.125,

Then: Nose Gear Leg part number is U-603-2 or U-603-3.

Action: Proceed to Step 2.

## **Step 2: (All 2 seat, tri-gear RV's)**

Measure Nose Wheel Fork height as shown in Figure 3.

If: Height measures 3.8 inches,

Then: Nose Gear Leg part number is U-603-2 (RV-6A/7A/9A)  
or U-809-1 (RV-8A)

Action: Nose Gear Leg must be modified or replaced and Nose Wheel Fork must be replaced.

If: Height measures 2.8 inches,

Then: Nose Gear Leg part number is U-603-3 (RV-6A/7A/9A)  
or U-809-2 (RV-8A)

Action: None required.

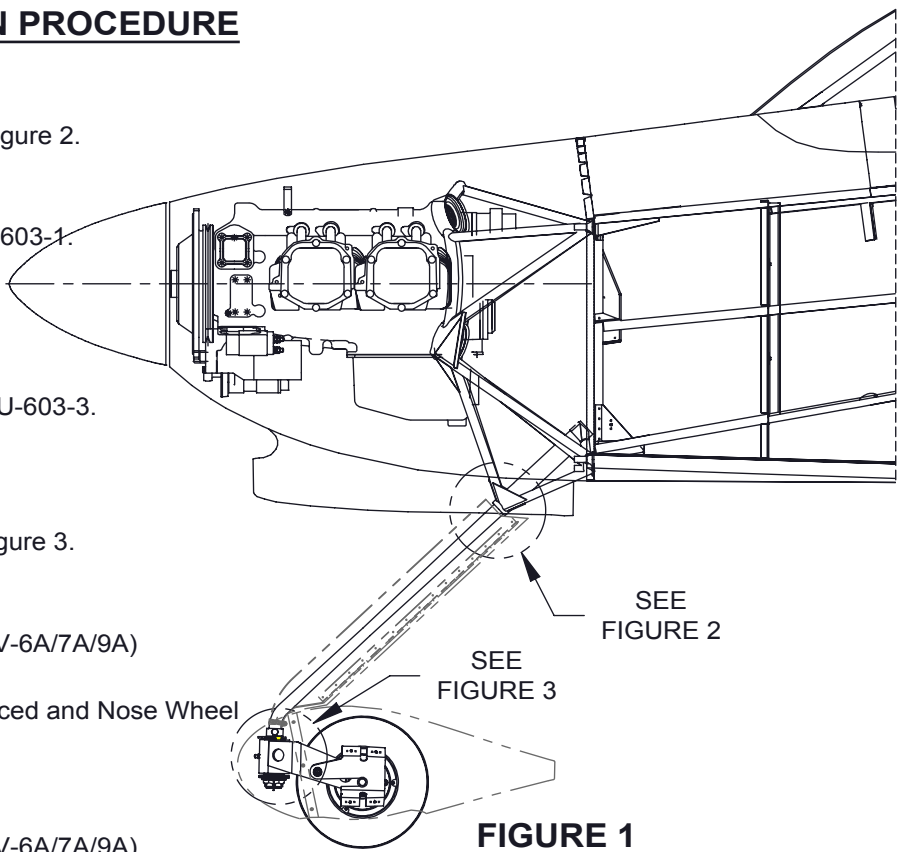

**FIGURE 1**  
**NOSE GEAR LEG IDENTIFICATION**

