

**NOTE:**  
END APPROACH COVERS TO BE CUT FROM EXTRUDED CONTACT RAIL COVER.

**END APPROACH COVERS**  
NOT TO SCALE

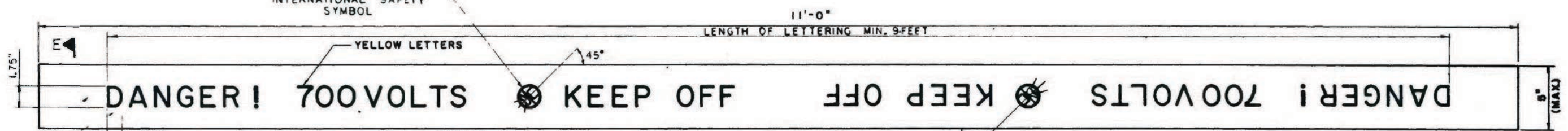
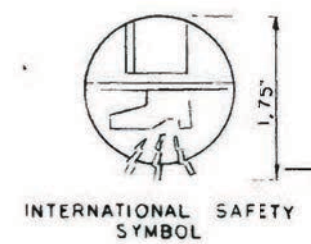
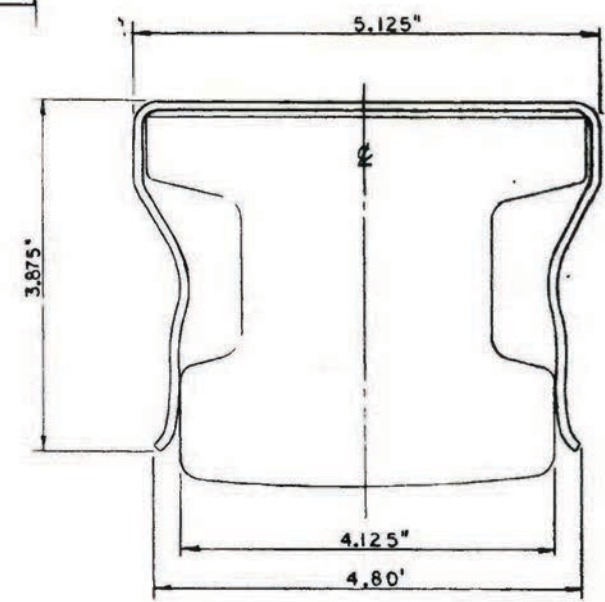
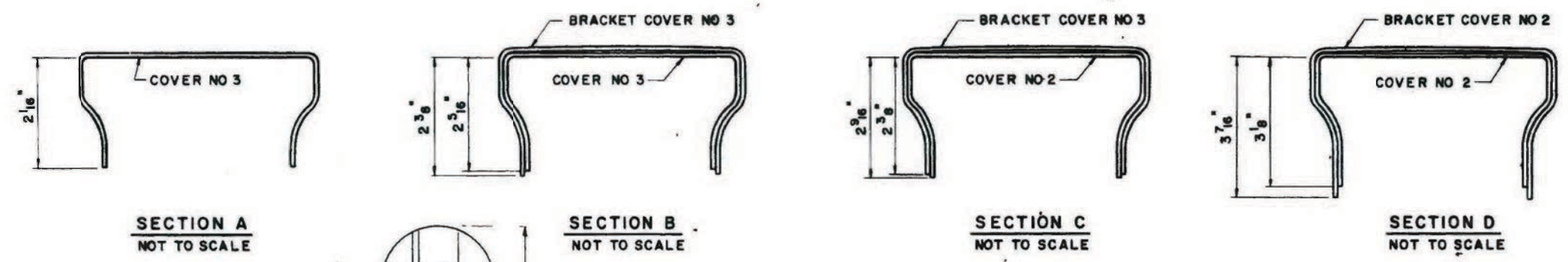

**PLAN**  
**150 LB CONTACT RAIL COVER**  
SCALE 1" = 4"

TOLERANCES: EXCEPT AS NOTED  
LINEAR: ± 0.015"  
ANGULAR: ± 1'

**SECTION E-E**  
SCALE: FULL SIZE  
MATERIAL THICKNESS 0.09" MIN.

METRO NORTH # SP-601  
TITLE 150 LB CONTACT RAIL COVER AND END APPROACH COVERS  
SPEC PD-808

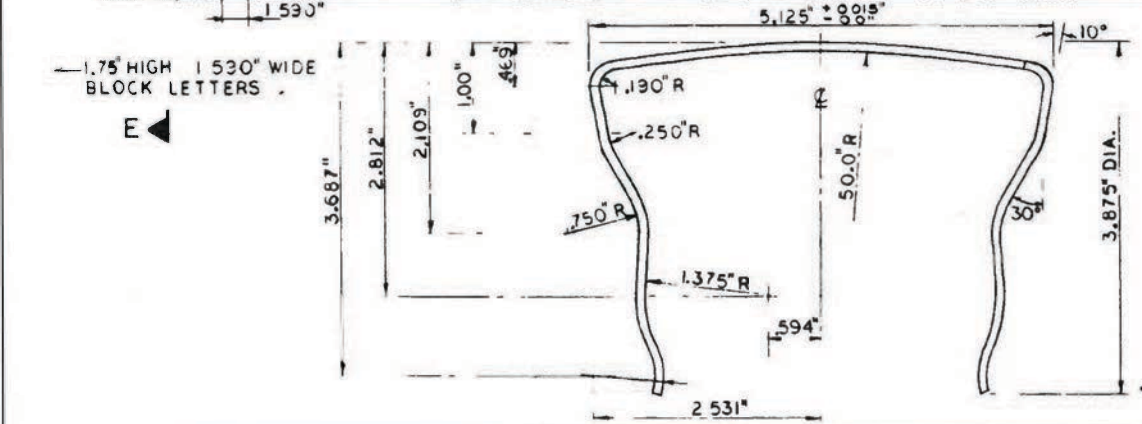

DATE	DESCRIPTION	DATE	DESCRIPTION

**MTA Metro-North Railroad Power Department**

150 LB. CONTACT RAIL COVER AND END APPROACH COVERS

DATE	3/3/86
SCALE	NONE
SHEET	1 OF 1
DRAWING #	SP-601

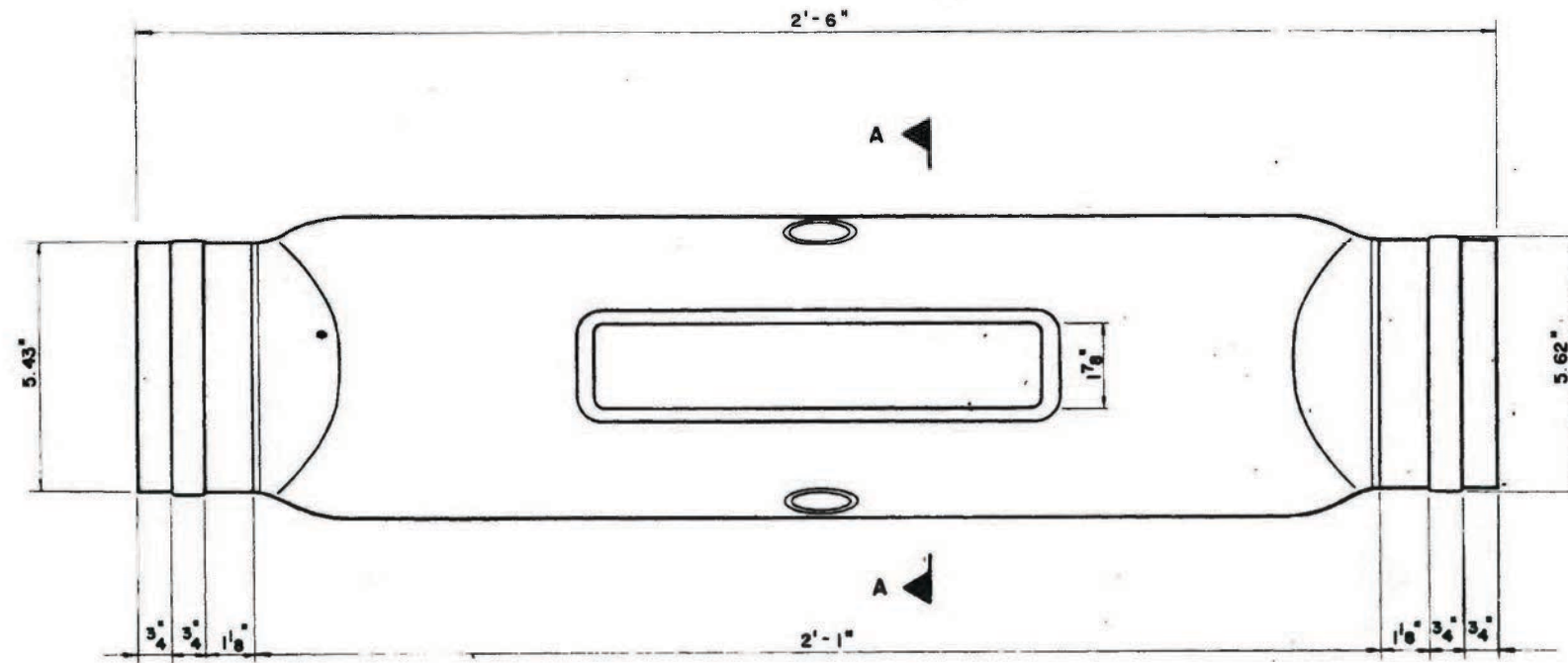

**PLAN**  
 NOT TO SCALE

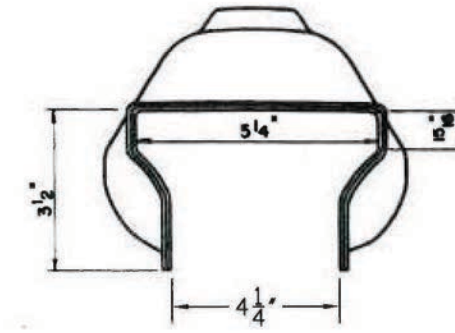

**ELEVATION**

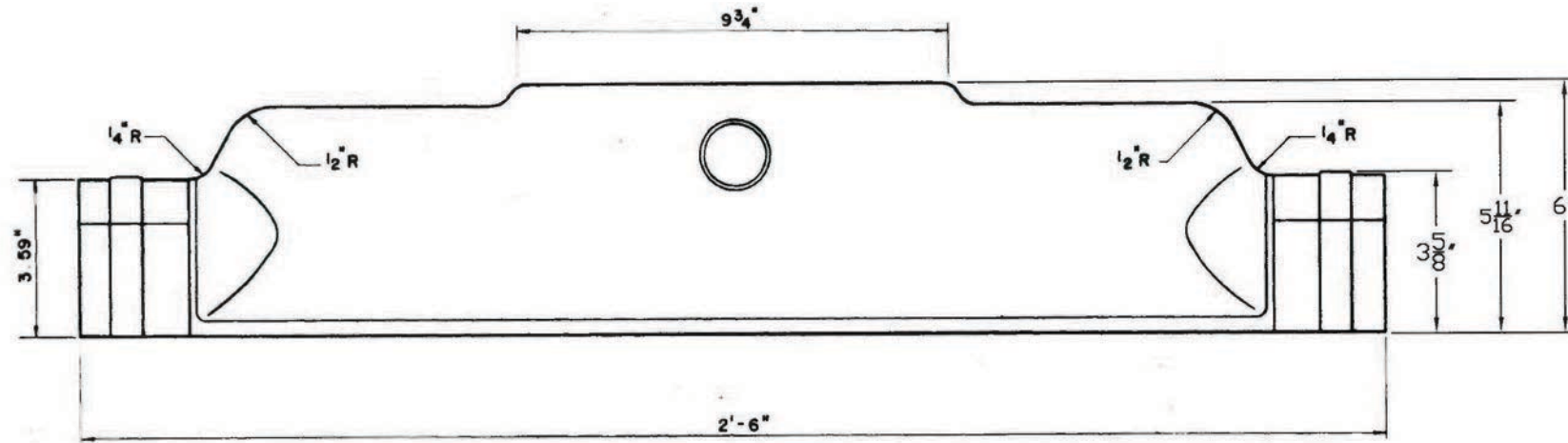

**ELEVATION**

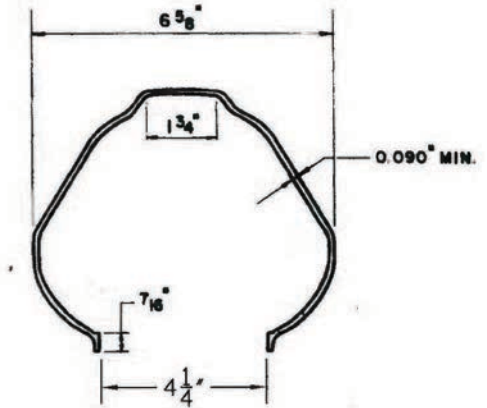

**SECTION A**

		1	7/16/2002	REVISED DIMENSIONS	ASS'T CHIEF ENGINEER	SUPERVISOR-POWER DESIGN	<b>Metro-North Railroad</b> Power Department
DATE	DESCRIPTION	#	DATE	DESCRIPTION	ASS'T CHIEF ENGINEER	SUPERVISOR-POWER DESIGN	

CONTACT RAIL SPLICE COVER

DATE	3/3/86
SCALE	NONE
SHEET	1 OF 1
DRAWING #	SP-602

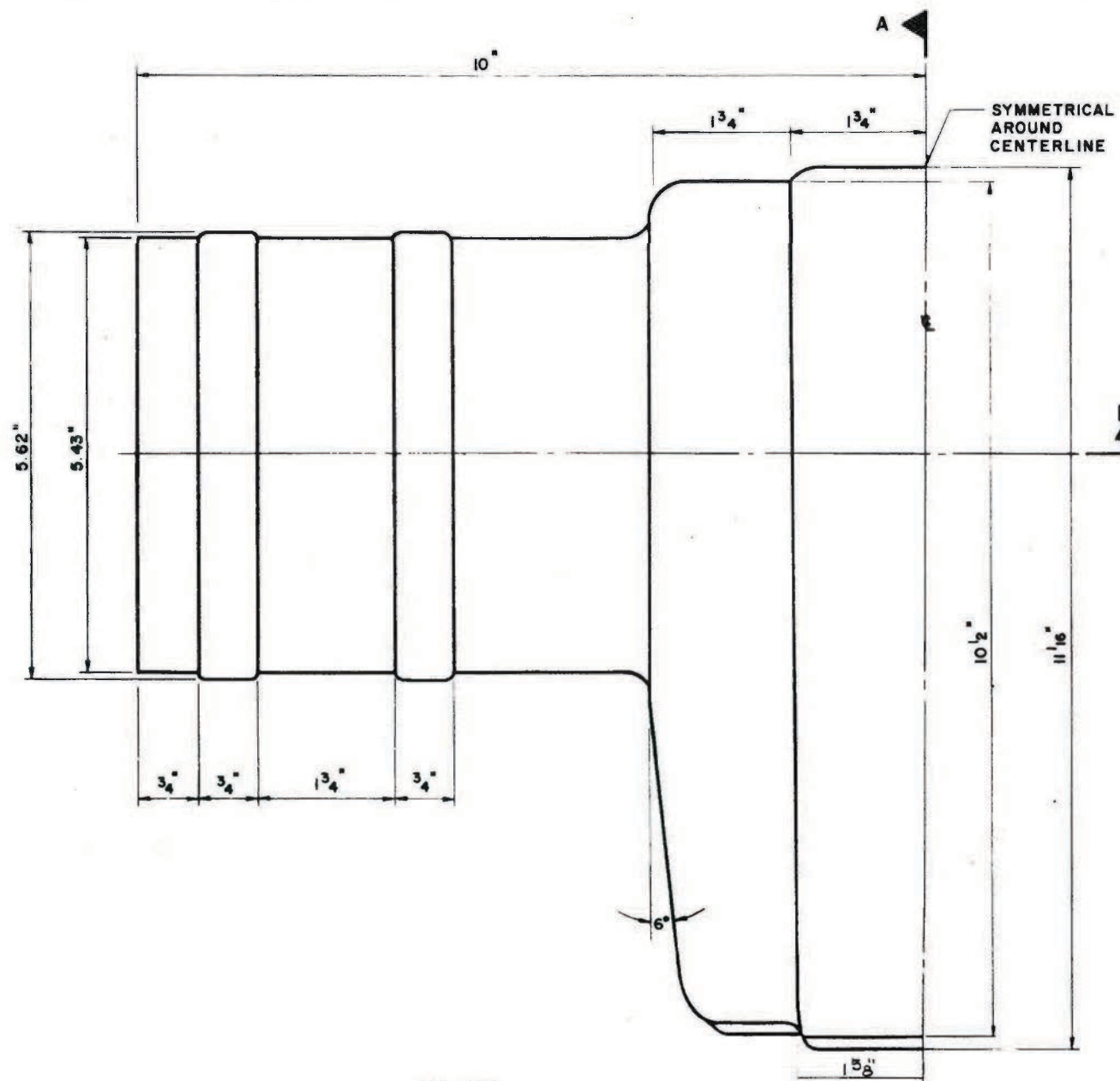

PLAN  
NOT TO SCALE

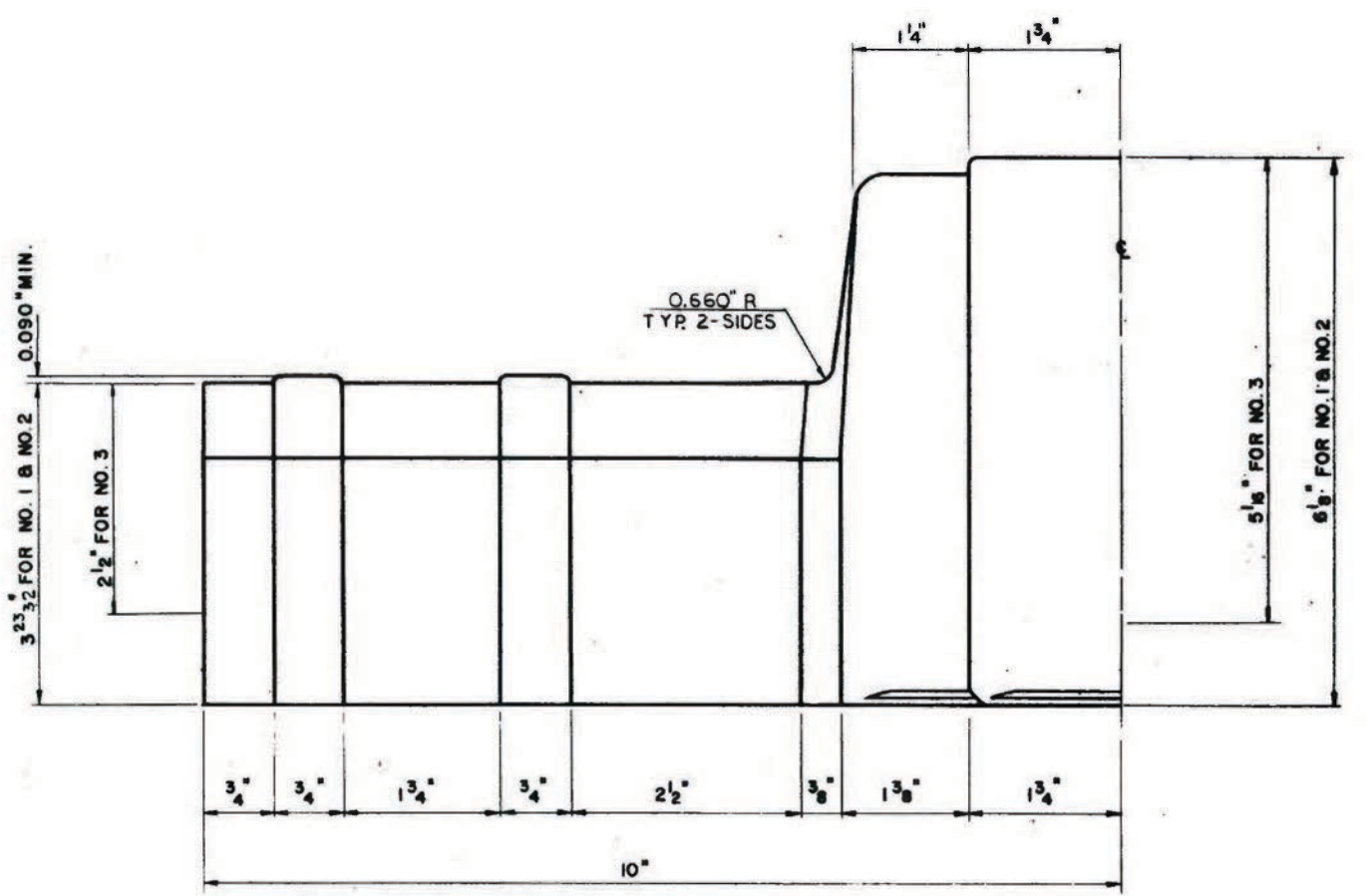

ELEVATION  
NOT TO SCALE

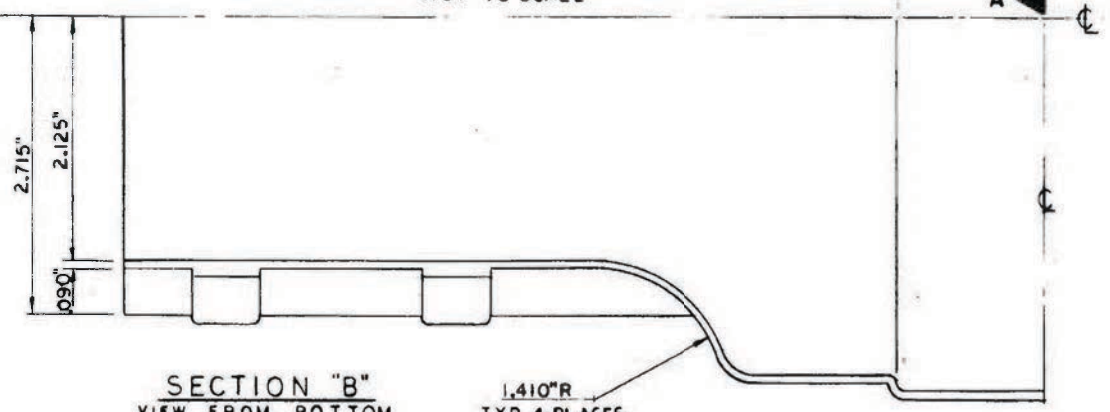

SECTION "B"  
VIEW FROM BOTTOM  
NOT TO SCALE

1. SECTION "A" SHOWN ON DWG. No. SP-604
2. SPECIFICATION No. PD-808

RECEIVED  
 MAR 3 1986  
 METRO NORTH RAILROAD  
 POWER DEPARTMENT

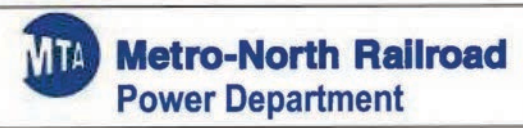

BRACKET COVER  
 150 LB THIRD RAIL  
 TYPE 1

DATE	3/3/86
SCALE	NONE
SHEET	1 OF 2
DRAWING	SP-603

DATE	DESCRIPTION	DATE	DESCRIPTION
1/30/2013	REVISED NOTES		

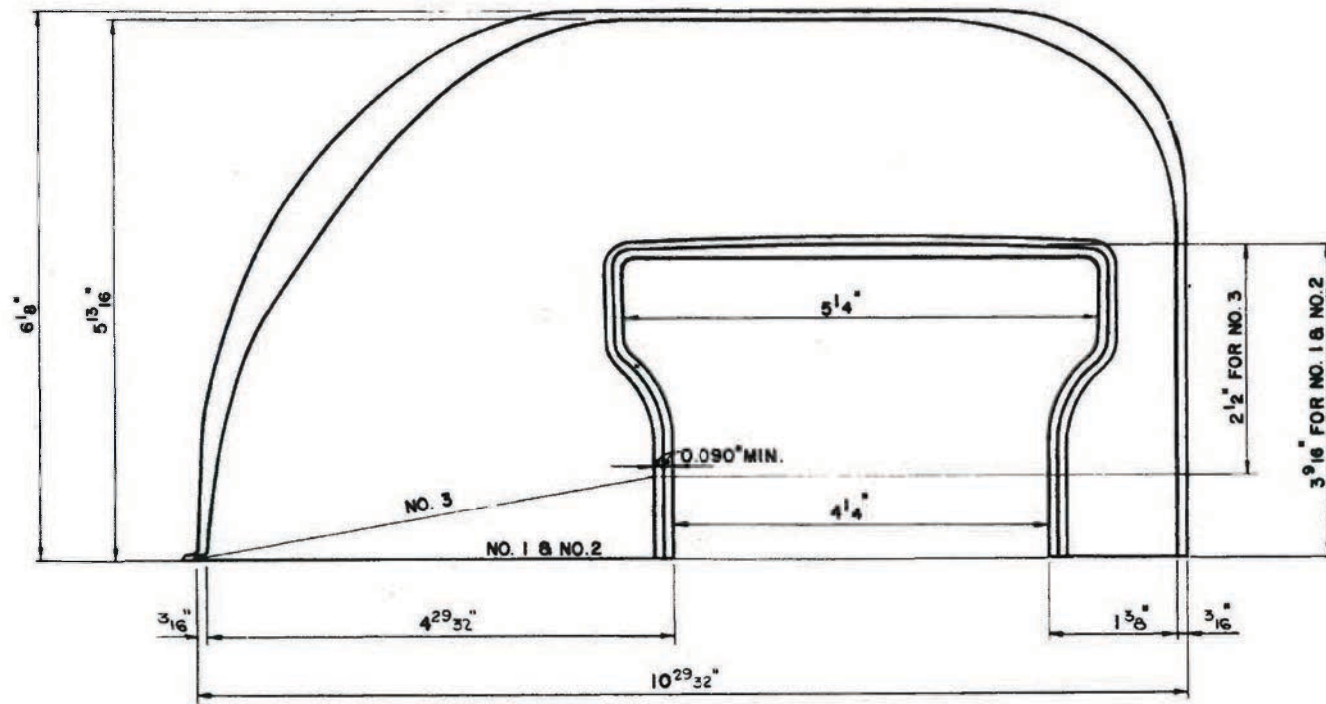

ELEVATION  
NOT TO SCALE

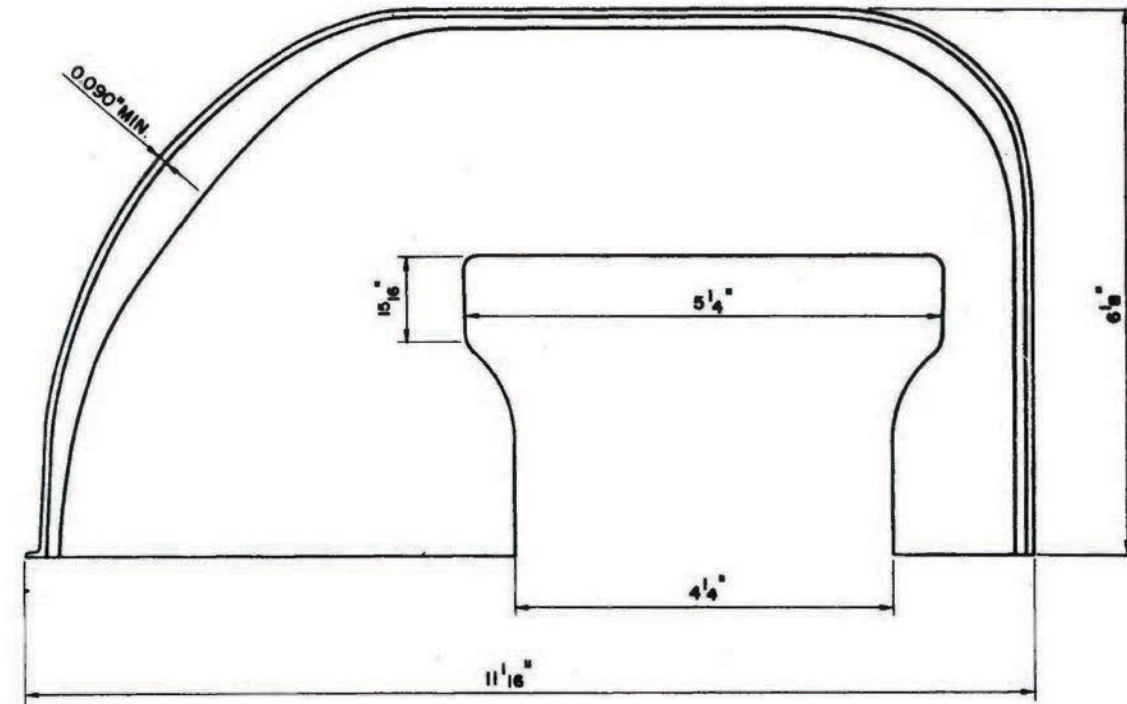

SECTION A  
(TYPE 1)

1. SEE DWG. SP-603 FOR PLAN VIEW
2. SPECIFICATION No. PD-808

RECEIVED  
MAR 3 1986  
METRO NORTH COAST RAILROAD  
POWER DEPARTMENT

#	DATE	DESCRIPTION	#	DATE	DESCRIPTION
1	1/30/2013	REVISED NOTES			

DIRECTOR POWER SYSTEMS  
 ASST CHIEF ENGINEER  
 ASST CHIEF ENGINEER  
 SUPERVISOR POWER DESIGN

**Metro-North Railroad**  
 Power Department

BRACKET COVER  
 150 LB THIRD RAIL  
 TYPE 1

DATE 3/3/86  
 SCALE NONE  
 SHEET 2 OF 2  
 DRAWING SP-604  
 POWER\SCAN\DR133