

WITTMAN FIELD – OSHKOSH, WI
(EXPERIMENTAL AIRCRAFT ASSOCIATION – CONVENTION 2006)

07-30-06 1207 HRS.
TAXIWAY COLLISION
(PAPA TAXIWAY)

NTSB IDENTIFICATION NO: CHI06FA206A

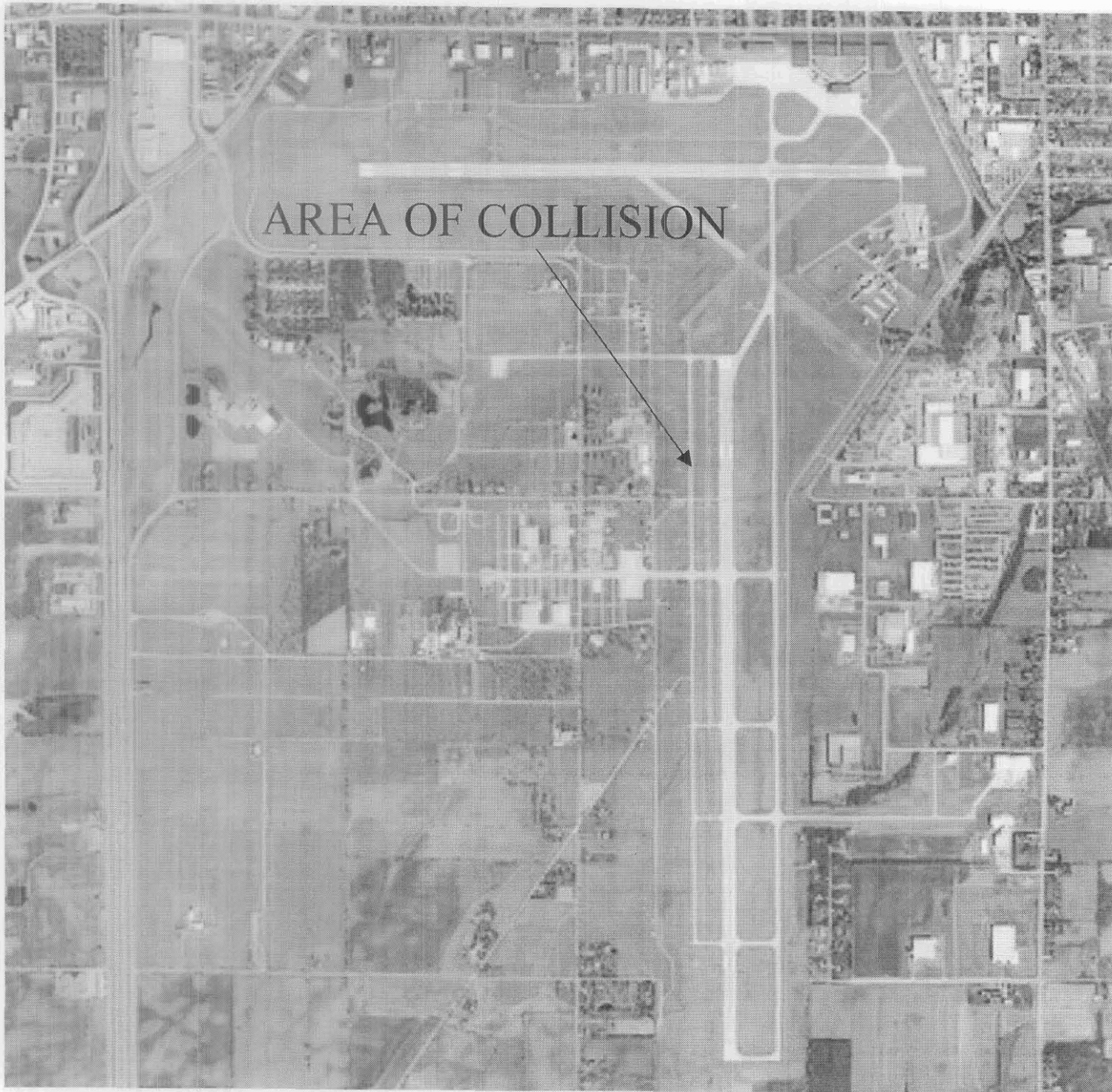
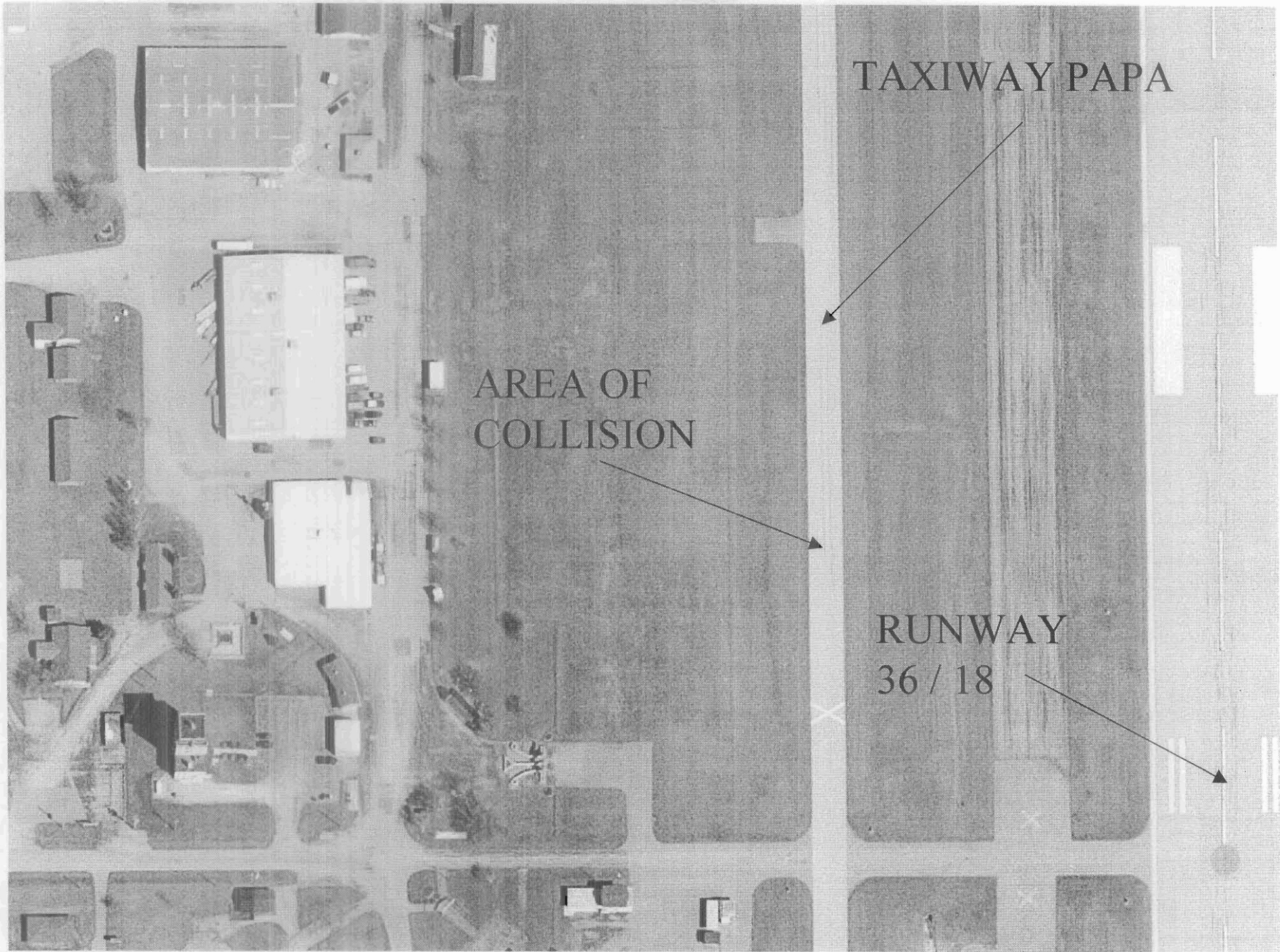

AREA OF COLLISION



TAXIWAY PAPA

AREA OF
COLLISION

RUNWAY
36 / 18

ON 08-08-06 AT 0800 HRS. VISIBILITY MEASUREMENTS WERE GATHERED USING THE TBM AVENGER AND AN EXEMPLARY RV-6 AIRCRAFT.

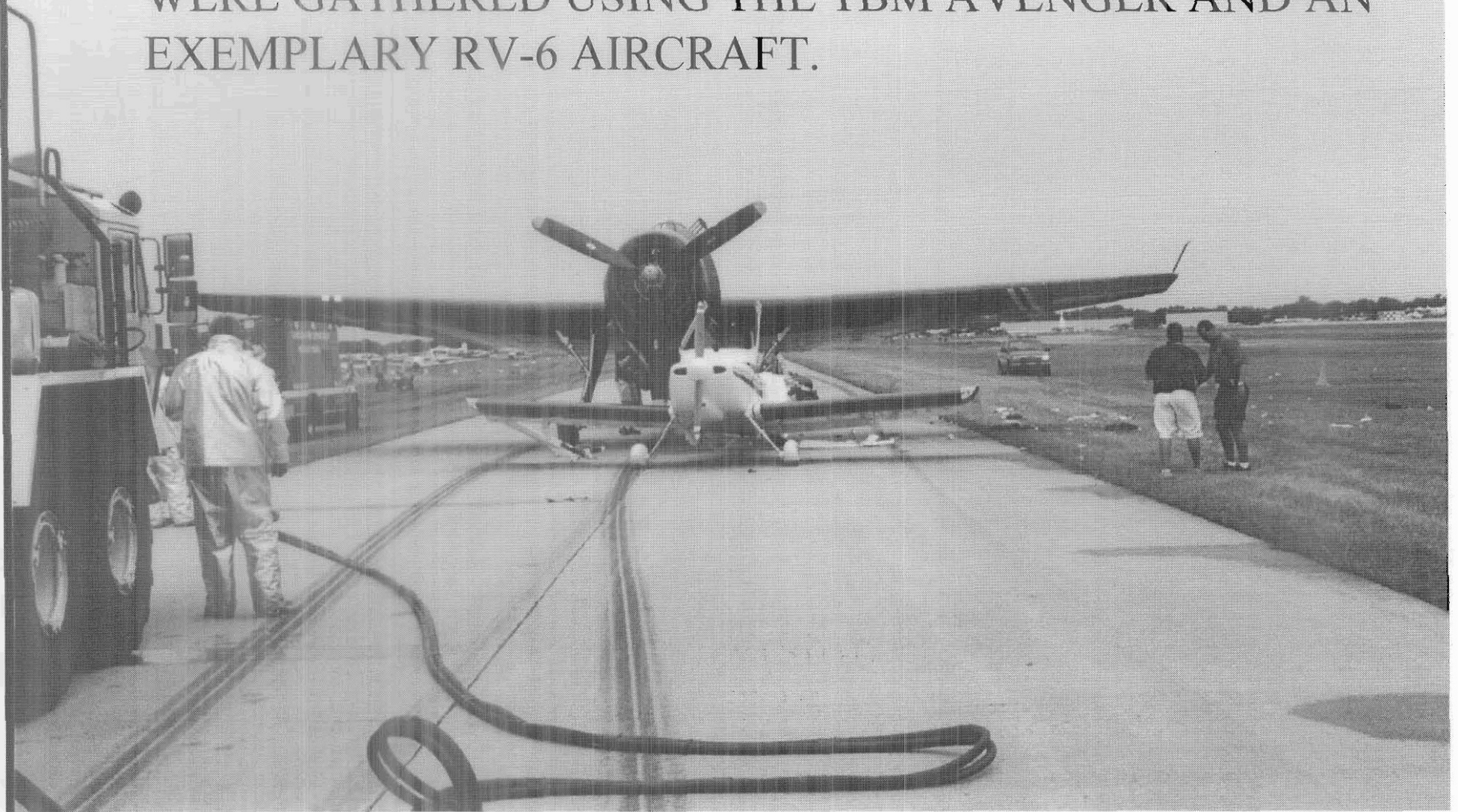

WINNEBAGO COUNTY SHERIFF'S DEPARTMENT
ACCIDENT FIELD SKETCH

* NOT TO SCALE *

Location: WITTMAN FIELD P-1 TAXIWAY	Date: 08-08-06	Time: 0800
Measurements by: PUTZER W20	Drawn by: PUTZER W20	
Document No: 06-3364		



Indicate North
by Arrow

DISTANCES
MEASURED AT A
HEIGHT OF 5'±

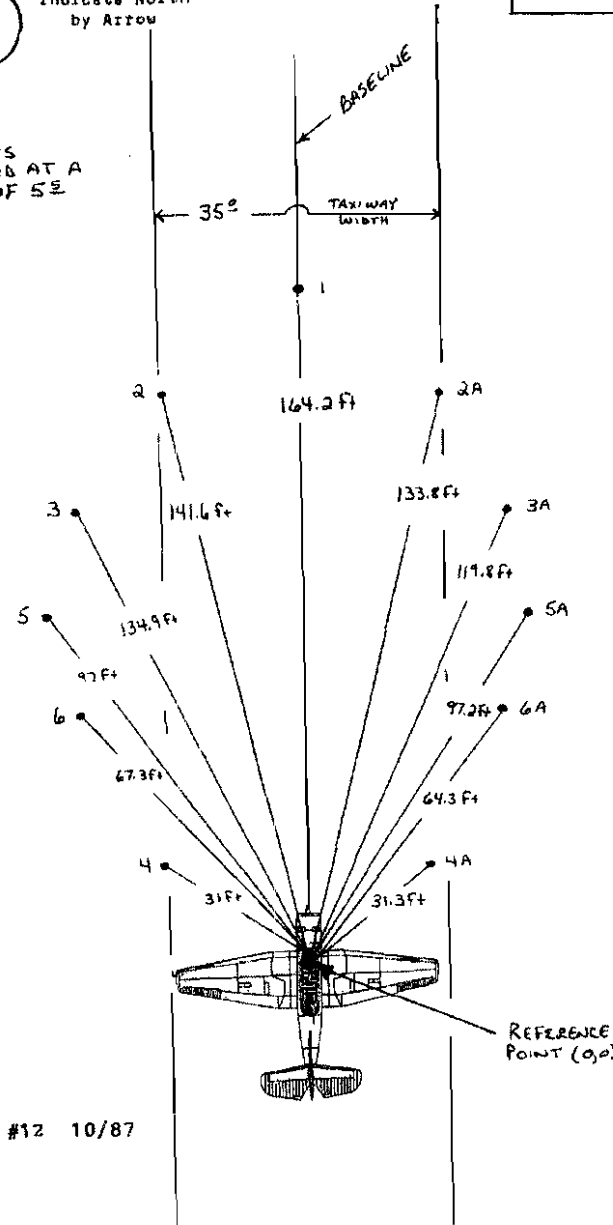

PT	N/S	E/W
1	170°S	0°E
2	145°S	10°E
2A	139°S	12°W
3	133°S	17°E
3A	121°S	17°W
4	29°S	13°E
4A	29°S	10°W
5	96°S	18°E
5A	96°S	21°W
6	65°S	15°E
6A	65°S	16°W
H		
I		
J		
K		
L		
M		
N		
O		
P		
Q		
R		
S		
T		
U		
V		
W		
X		
Y		
Z		
AA		
BB		
CC		
DD		
EE		
FF		
GG		
HH		
II		
JJ		
KK		
LL		
MM		
NN		
OO		
PP		
QQ		

WCSD #12 10/87

A LASER MEASUREMENT DEVICE WAS USED TO GATHER MEASUREMENTS OF AVAILABLE VISIBILITY.

THESE MEASUREMENTS WERE RECORDED ONTO A FIELD SKETCH.

WINNEBAGO COUNTY SHERIFF'S DEPARTMENT
ACCIDENT FIELD SKETCH

NOT TO SCALE

Location: WITTMAN FIELD P-1 TAXIWAY	Date: 08-08-06	Time: 0800
Measurements by: PUTZER W20	Drawn by: PUTZER W20	
Document No: 06-3364		

PERSONNEL SEATED IN THE TBM AVENGER ASSISTED IN THE GATHERING OF ADDITIONAL MEASUREMENTS OF AVAILABLE VISIBILITY.

AN EXEMPLARY RV-6 WAS USED TO ASSIST IN THIS MEASUREMENT PROCESS.

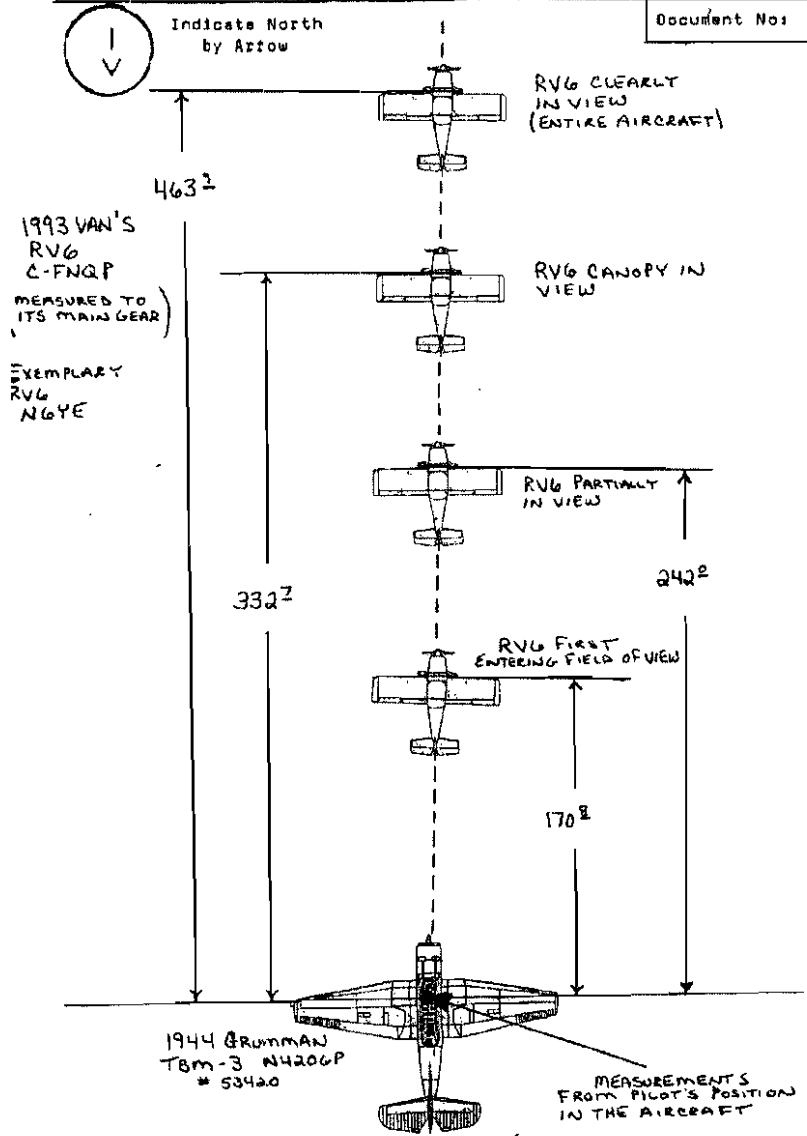

PT	N/S	E/W
A		
B		
C		
D		
E		
F		
G		
H		
I		
J		
K		
L		
M		
N		
O		
Q		
R		
S		
T		
U		
V		
W		
X		
Y		
Z		
A1		
B1		
C1		
D1		
E1		
F1		
G1		
H1		
I1		
J1		
K1		
L1		
M1		
N1		
O1		
P1		
01		

WCSD #12 10/87

EXEMPLARY PILOT:
BRIAN J. McBRYDE

(VISIBILITY MEASUREMENTS)

WINNEBAGO COUNTY SHERIFF'S DEPARTMENT
ACCIDENT FIELD SKETCH

* NOT TO SCALE *

Location: Wittman Field - Oshkosh, WI	P-1 TAXIWAY	Date: 08-08-06	Time: 0800
Measurements by: PUTZER W20		Drawn by: PUTZER W20	
		Document No: 06-3364	

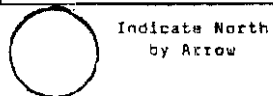

Indicate North
by Arrow

EXEMPLARY PILOT:
BRIAN J. McBRIDE HEIGHT 6'4"

1944 GRUMMAN TBM-3
N420GP #53420

MEASUREMENTS WERE
GATHERED SURROUNDING
THE POSITIONING OF THE
EXEMPLARY PILOT.

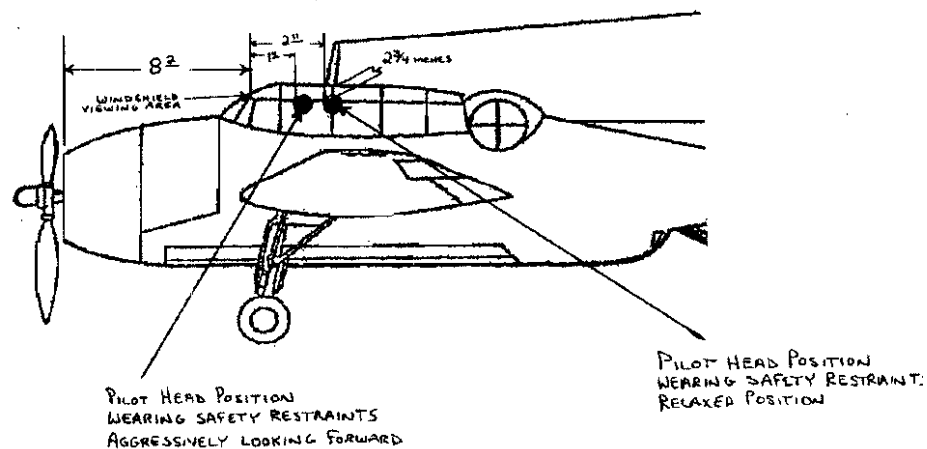

1/12 Scale Warbirds
<http://home.hawaii.rr.com/combat>

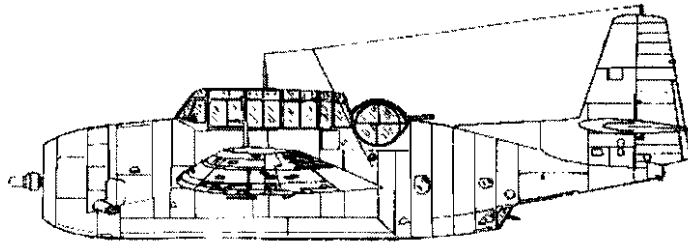

Specifications

TBM-3 Avenger

Wingspan	52 feet 2 inches
Length	40 feet
Height	16 feet 6 inches
Empty Weight	10,843 pounds
Maximum Weight	18,250 pounds
Powerplant	One Wright R-2600-20 rated at 1,900 hp

Armament	Two forward firing .50 caliber machine guns One .30 caliber machine gun in the ventral gun position One .50 caliber machine gun in a Grumman 160SE power turret
----------	--

Performance	
Maximum Speed	267 mph @ 16,000 feet
Service ceiling	23,400 feet
Range	1,130 miles
Crew	Three

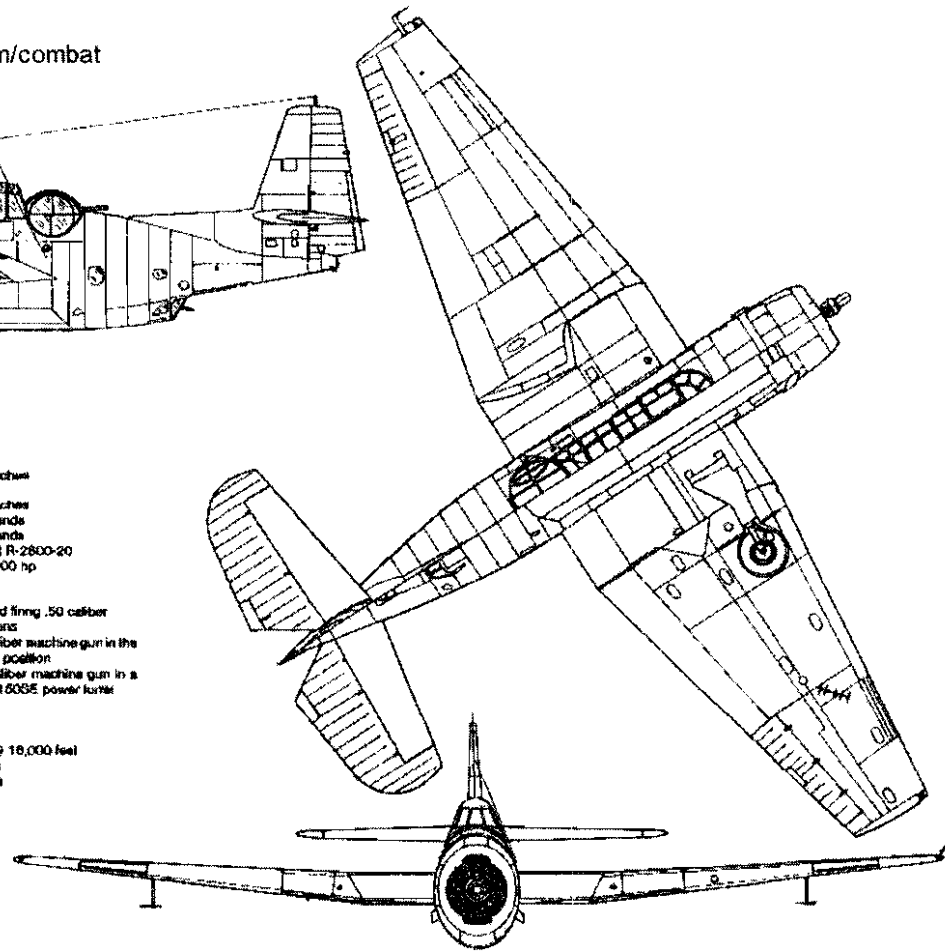

SCHEMATIC DRAWINGS WERE USED TO OBTAIN THE MEASUREMENTS NECESSARY TO COMPLETE SCALED, 2-DIMENSIONAL DRAWINGS OF BOTH THE TBM AVENGER AND THE RV-6.

1944 GRUMMAN TBM-3 AVENGER
WITTMAN FIELD WINNEBAGO COUNTY
07-30-06 12:11P 06-3364
DRAWN BY: D. PUTZER

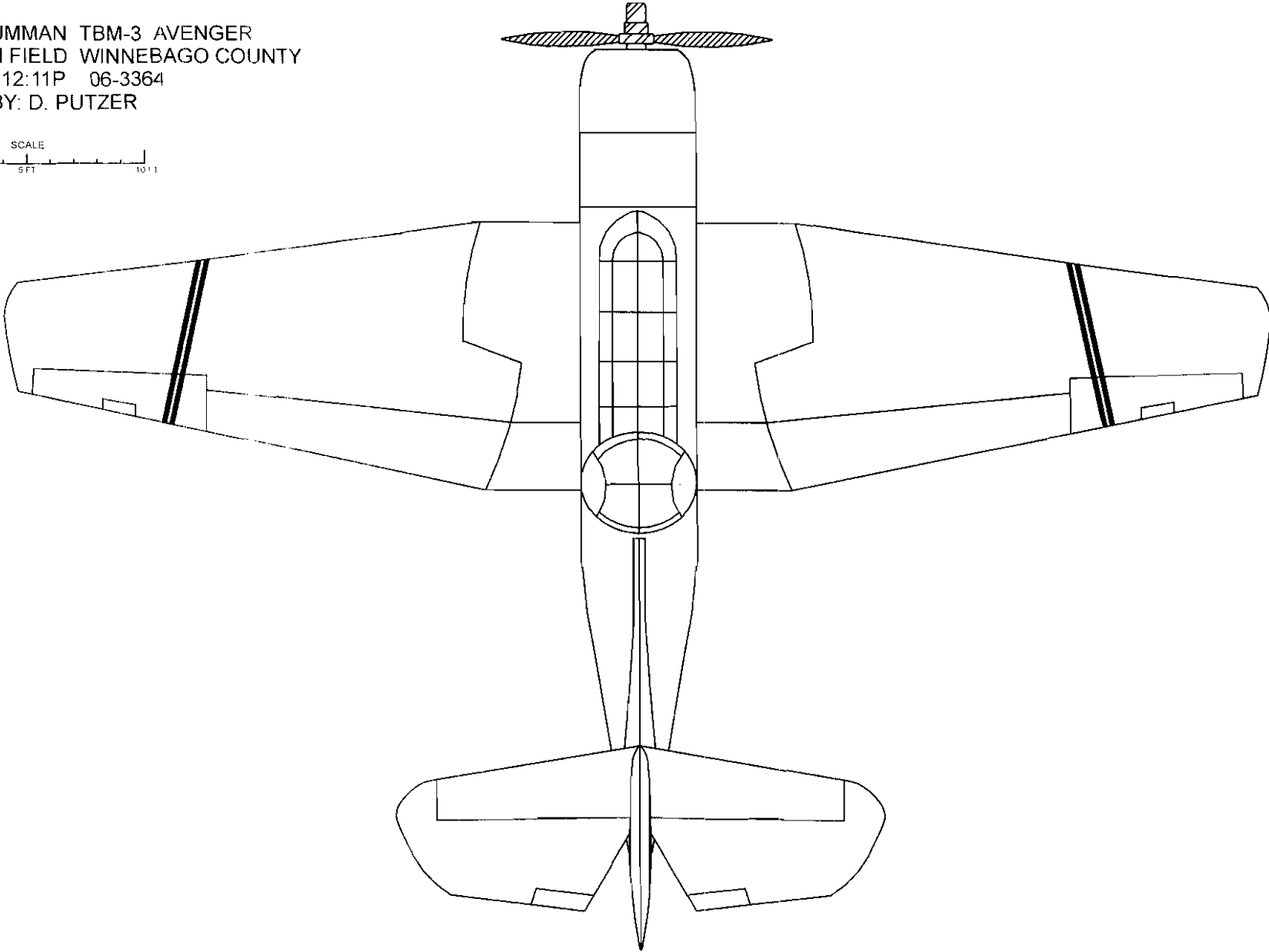
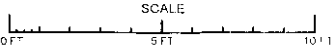

1993 VANS RV-6
07-30-06 12:11P WITTMAN FIELD
WINNEBAGO COUNTY 06-3364
DRAWN BY: D. PUTZER W20

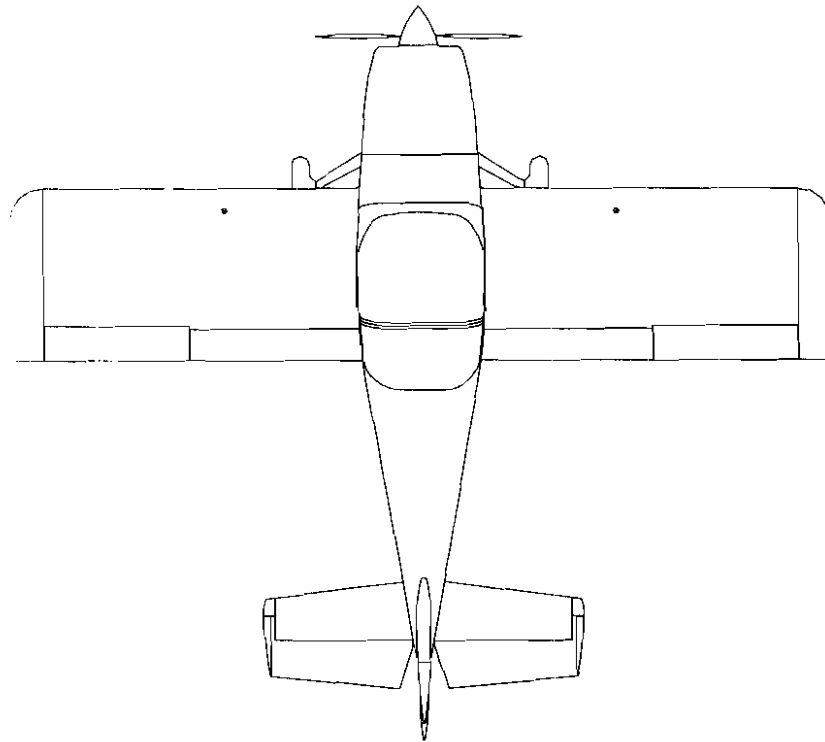
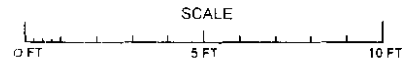

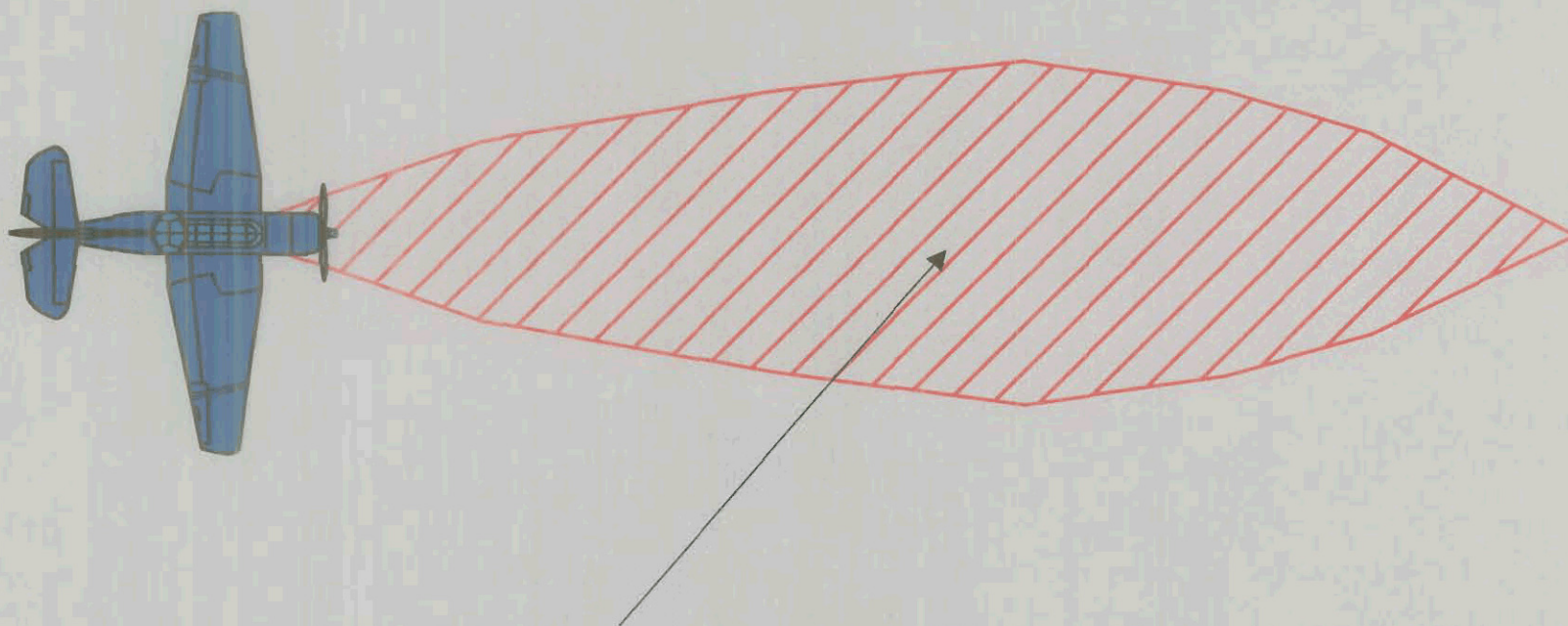

AREA OF ZERO FORWARD VISIBILITY.
(DETERMINED FROM THE
VISIBILITY / MEASUREMENT
STUDY CONDUCTED ON 08-08-06)

500 FT 400 FT 300 FT 200 FT 100 FT 0 FT



TAXIWAY PAPA ROTATED 90 DEGREES
COUNTER-CLOCKWISE. (DIAGRAM ADDED)

ESTIMATED SIMULATION WILL FOLLOW BEGINNING
WITH TBM AVENGER 200 FT BEHIND THE RV-6.
(NO "S" TURNS)

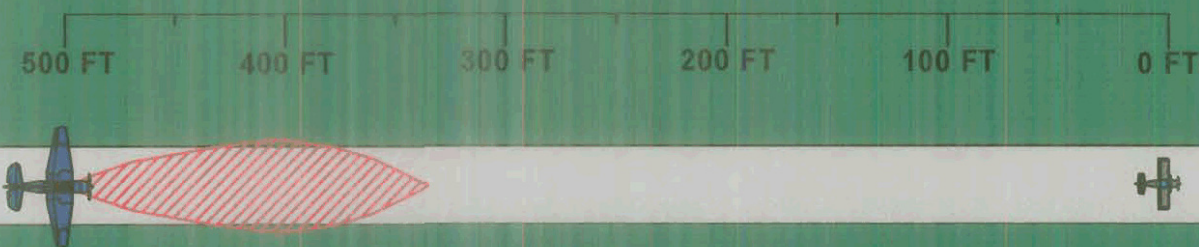

ESTIMATED SIMULATION WILL FOLLOW BEGINNING
WITH TBM AVENGER 200 FT BEHIND THE RV-6.
(NO "S" TURNS)



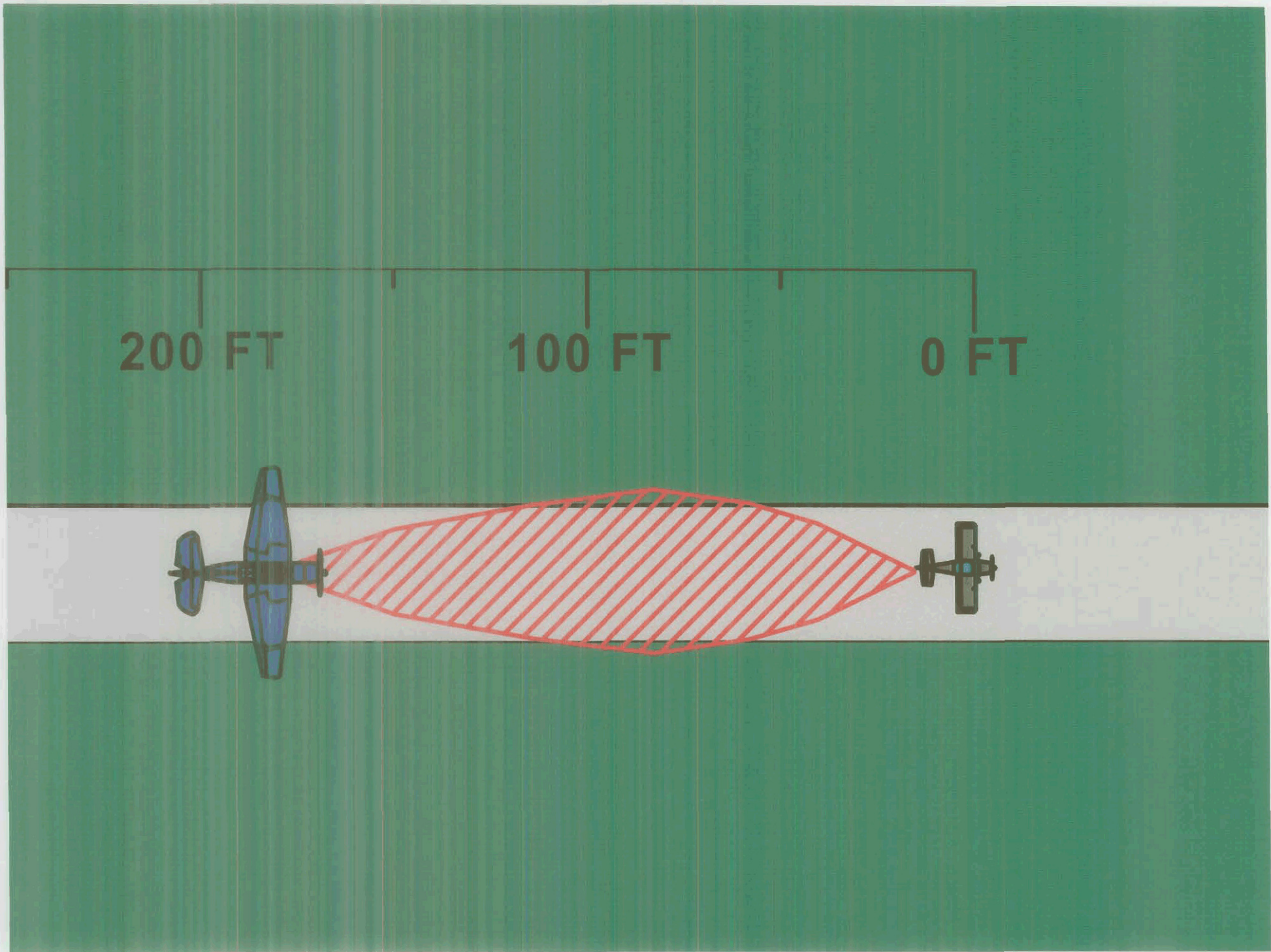

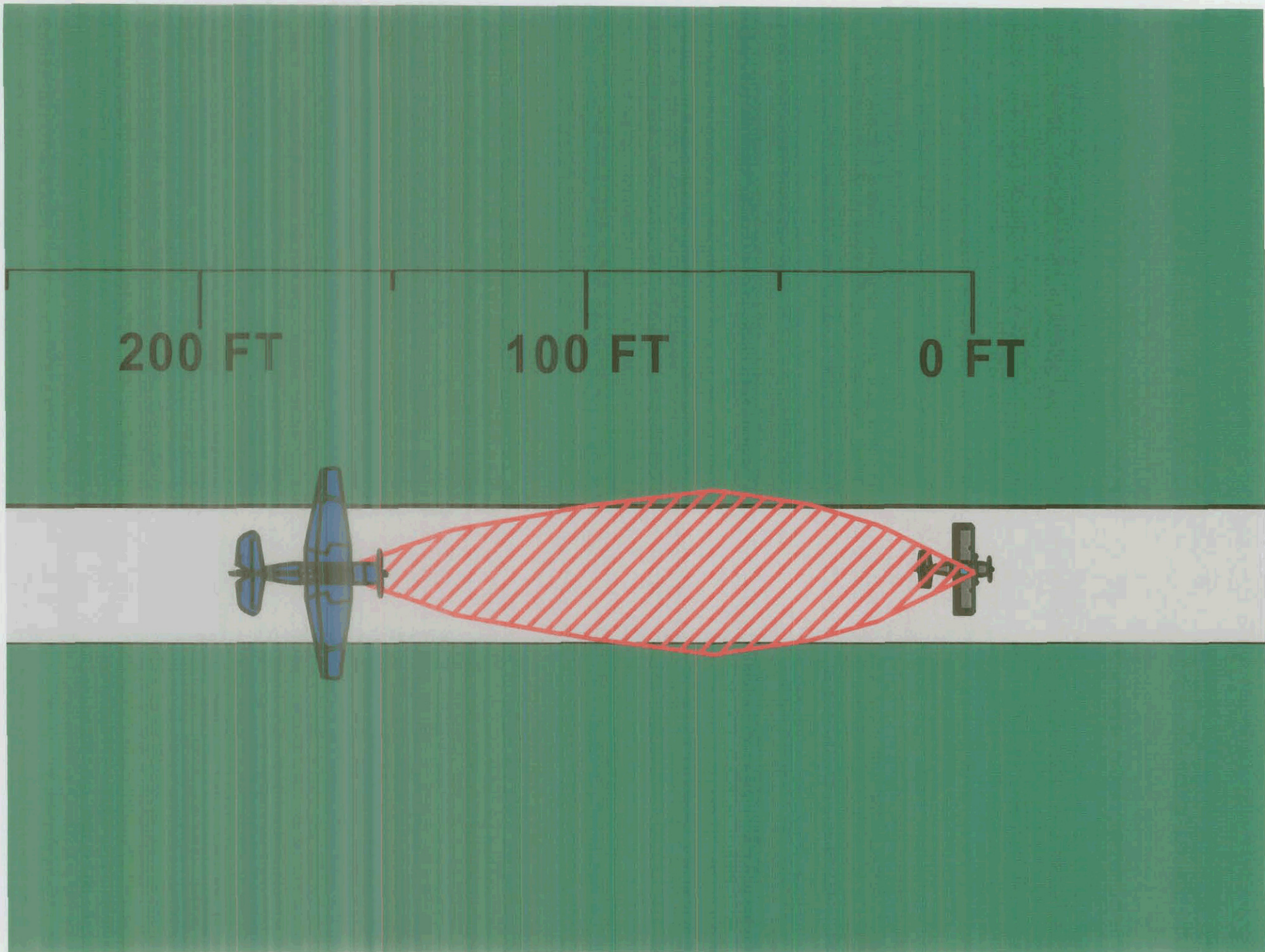

200 FT

100 FT

0 FT

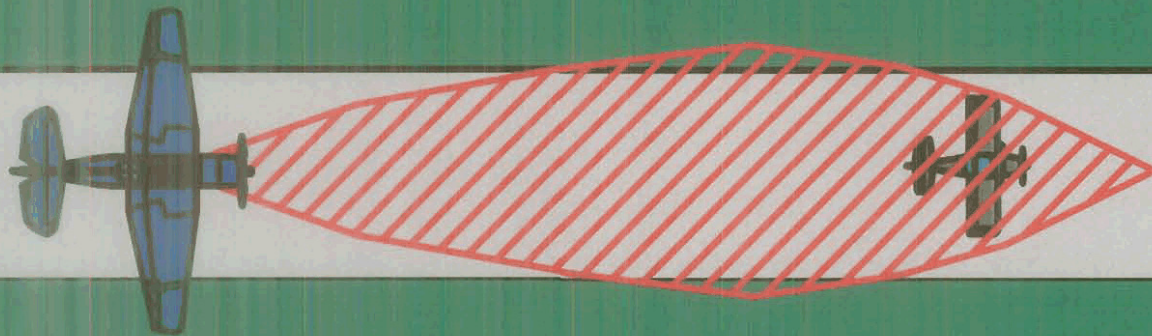

200 FT

100 FT

0 FT

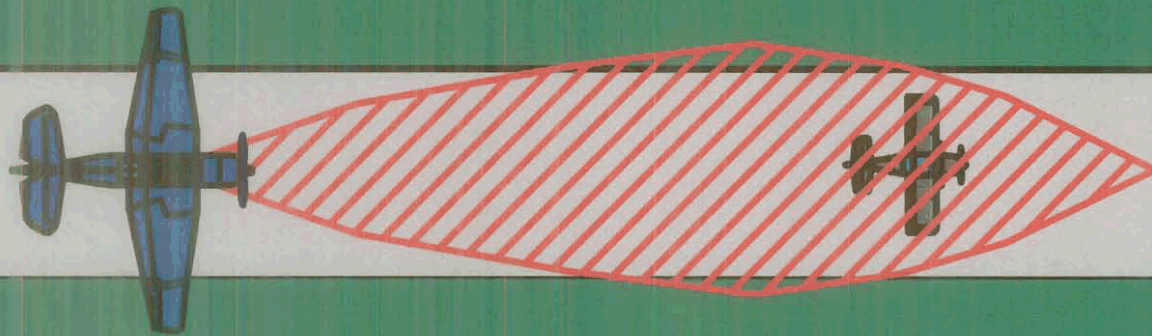

RV-6 IN AREA OF NO VISIBILITY

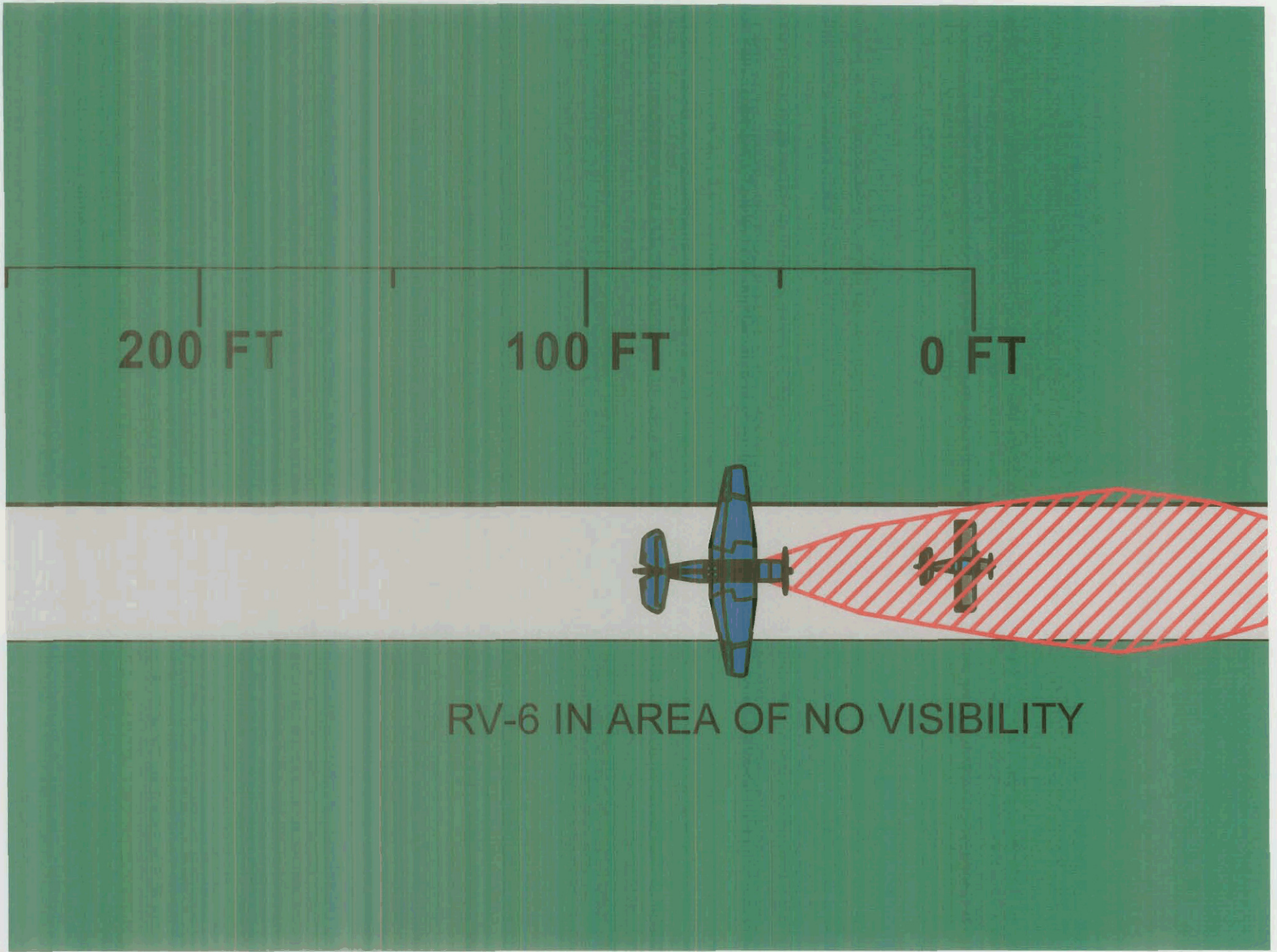

200 FT

100 FT

0 FT

RV-6 IN AREA OF NO VISIBILITY

200 FT

100 FT

0 FT

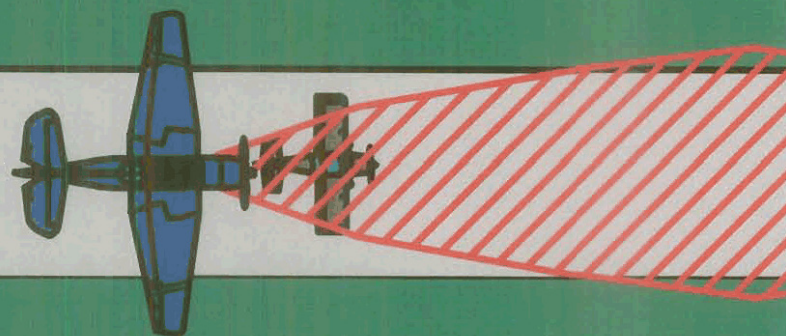

RV-6 WINGTIPS IN VIEW

ESTIMATED SIMULATION WILL FOLLOW - BEGINNING
WITH THE TBM AVENGER 200 FT BEHIND THE RV-6.

(20 DEGREE "S" TURNS IMPLEMENTED)

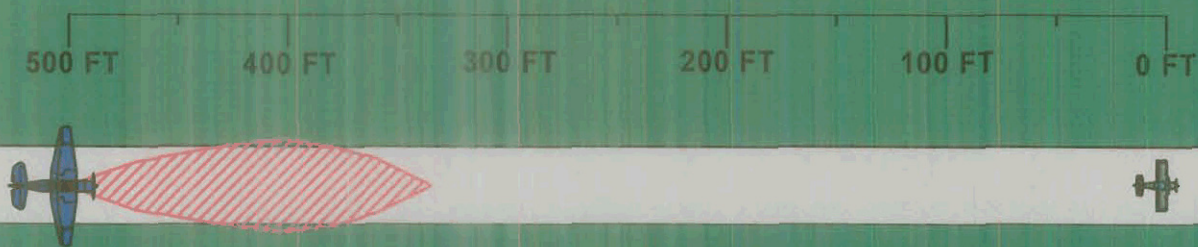

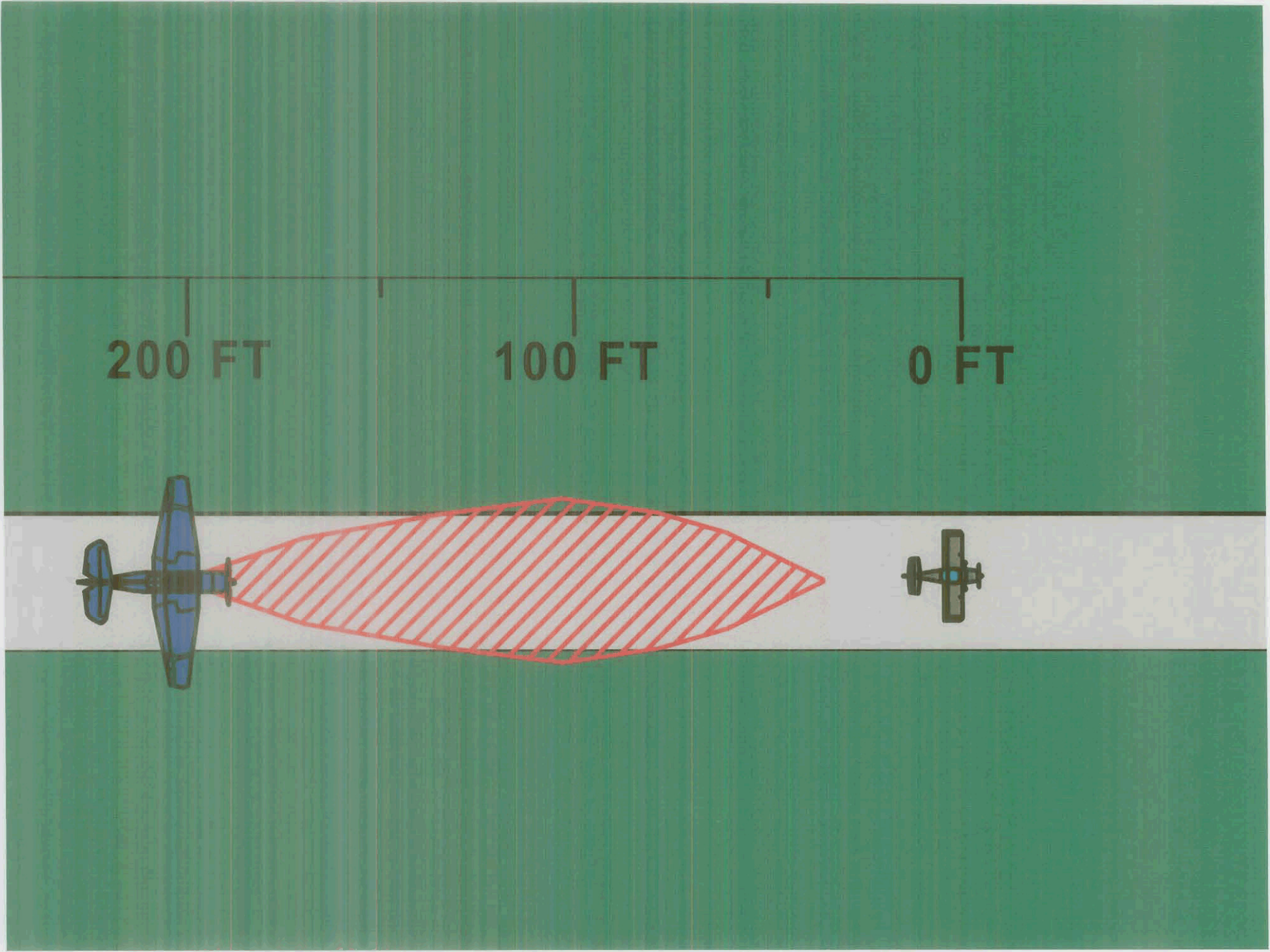

200 FT

100 FT

0 FT

200 FT

100 FT

0 FT

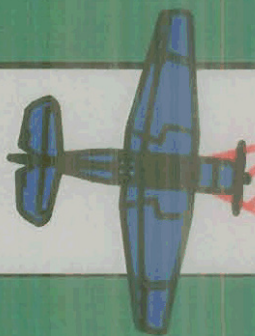

200 FT

100 FT

0 FT

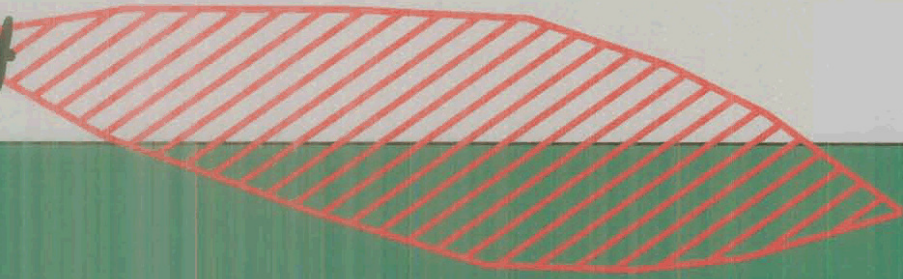
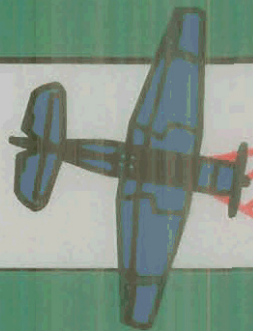

200 FT

100 FT

0 FT

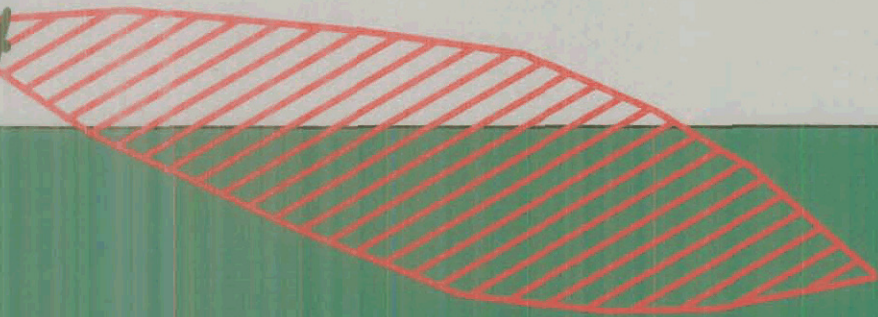
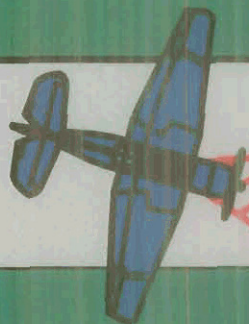

200 FT

100 FT

0 FT

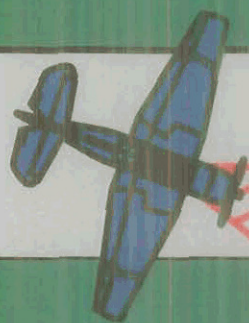

200 FT

100 FT

0 FT

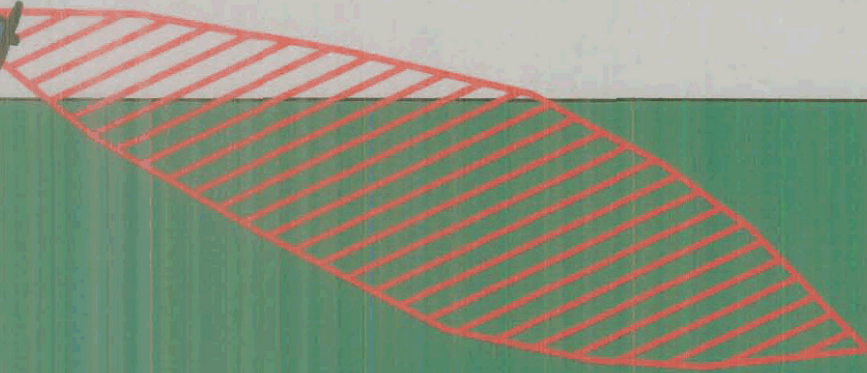
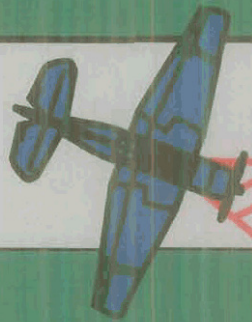

200 FT

100 FT

0 FT

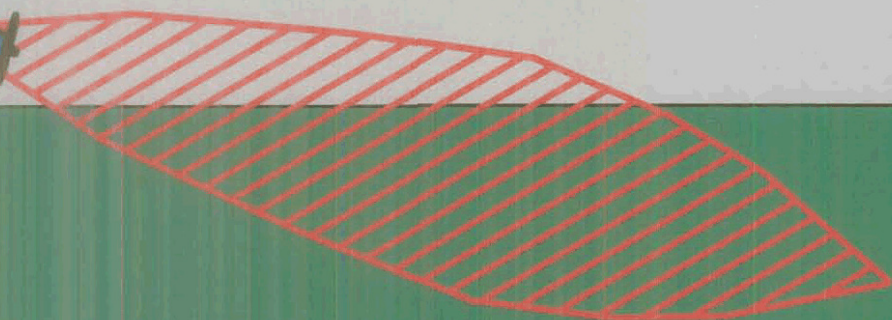
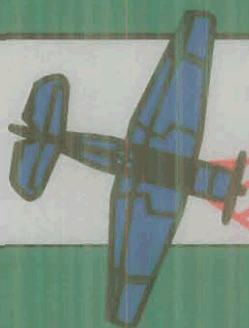

200 FT

100 FT

0 FT

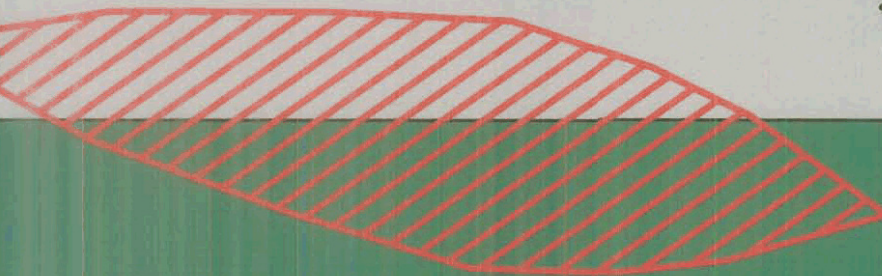
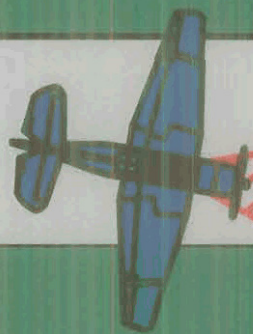

200 FT

100 FT

0 FT

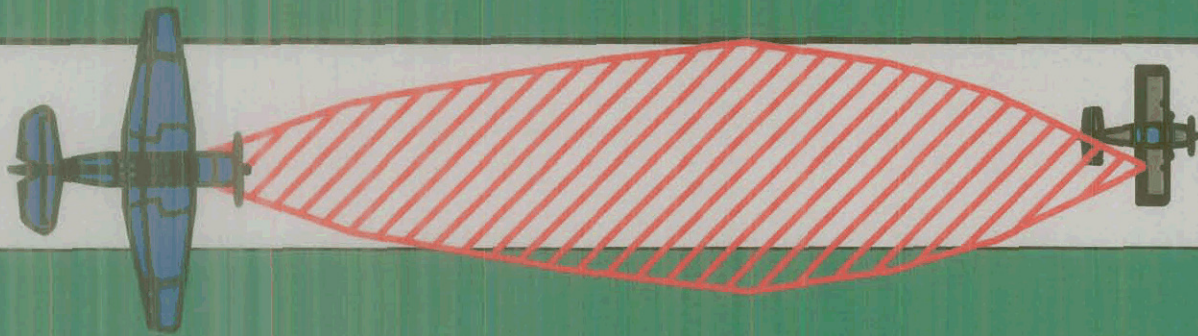

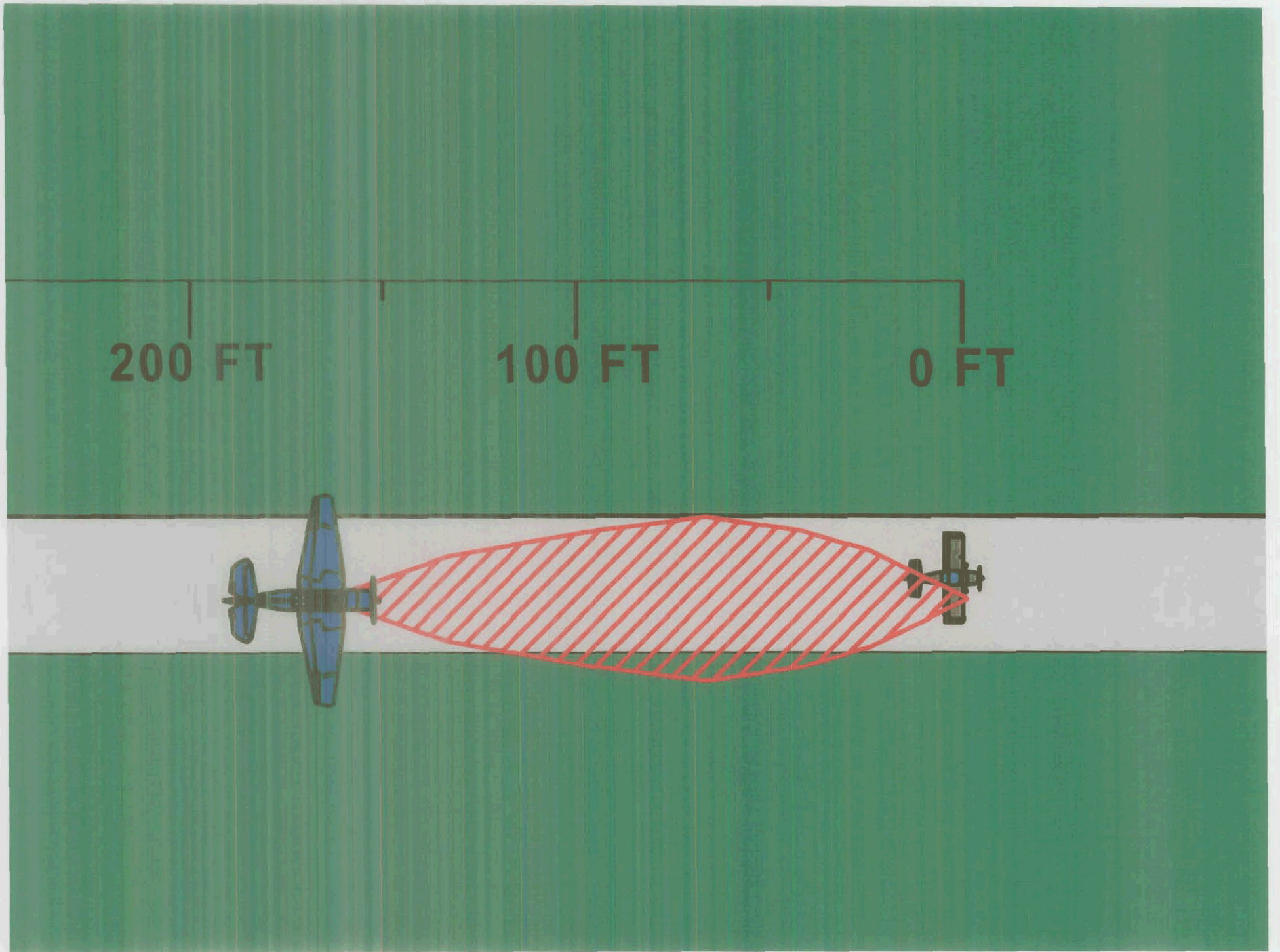

200 FT

100 FT

0 FT

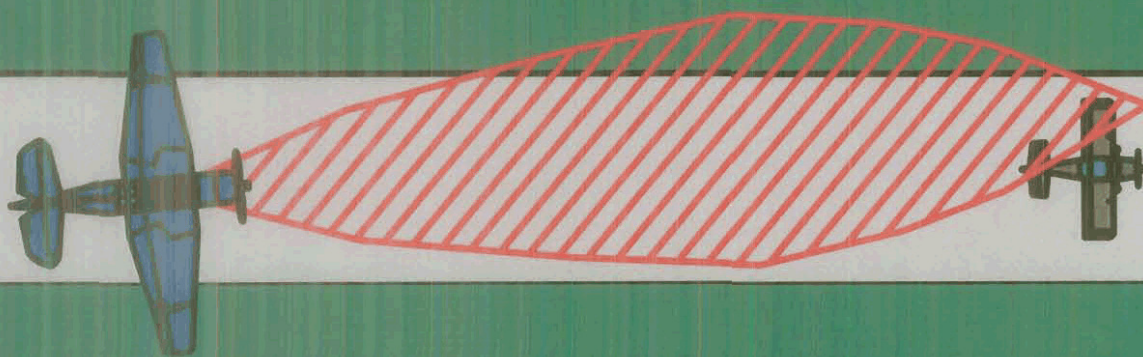

200 FT

100 FT

0 FT

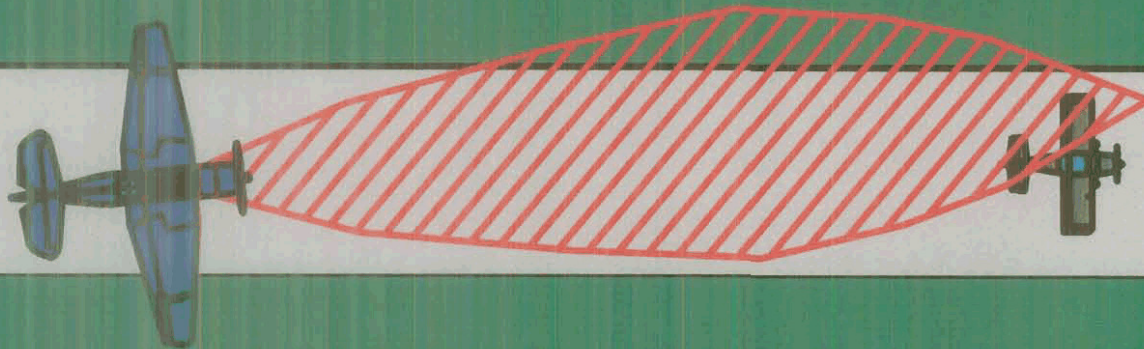

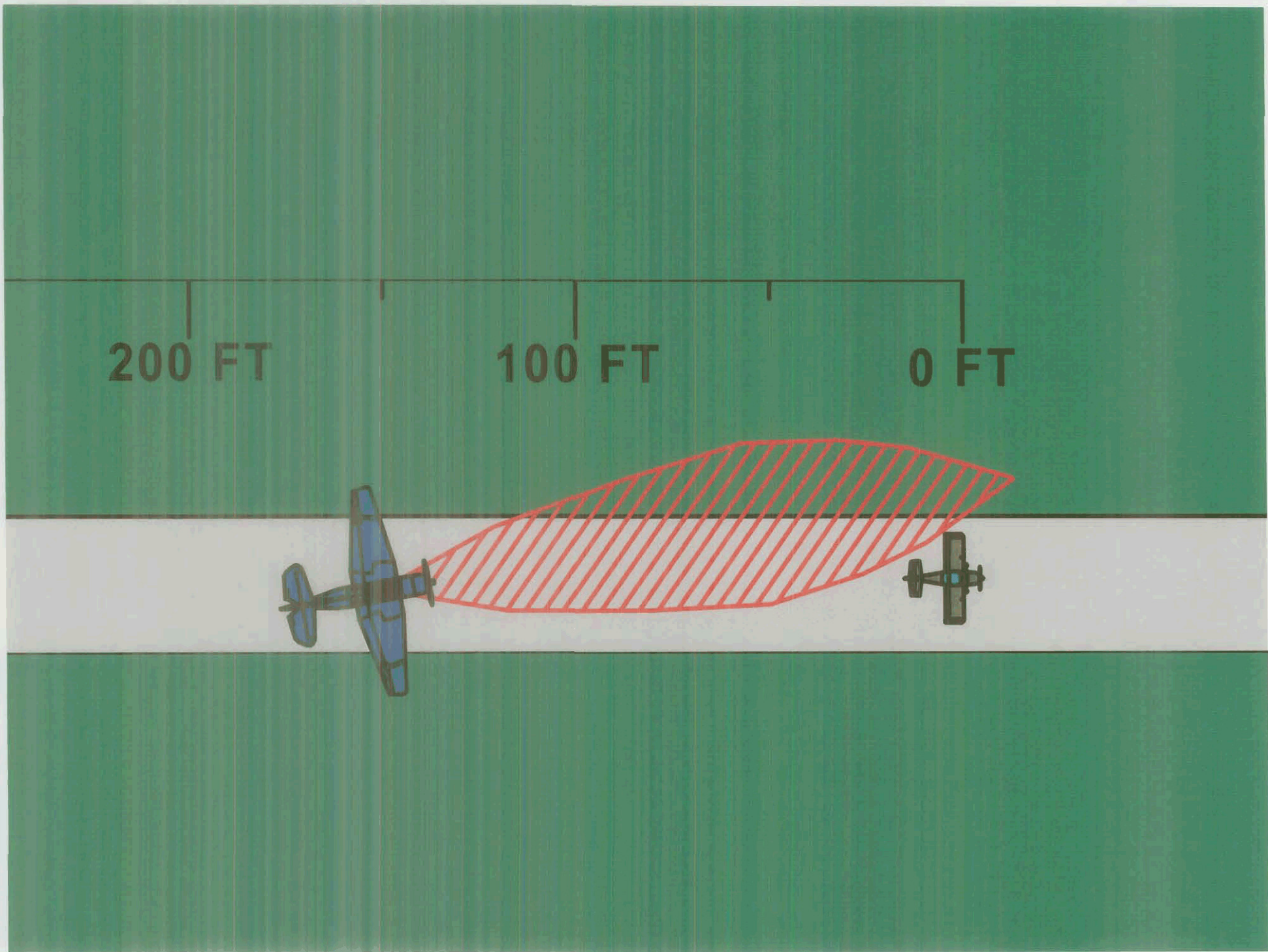

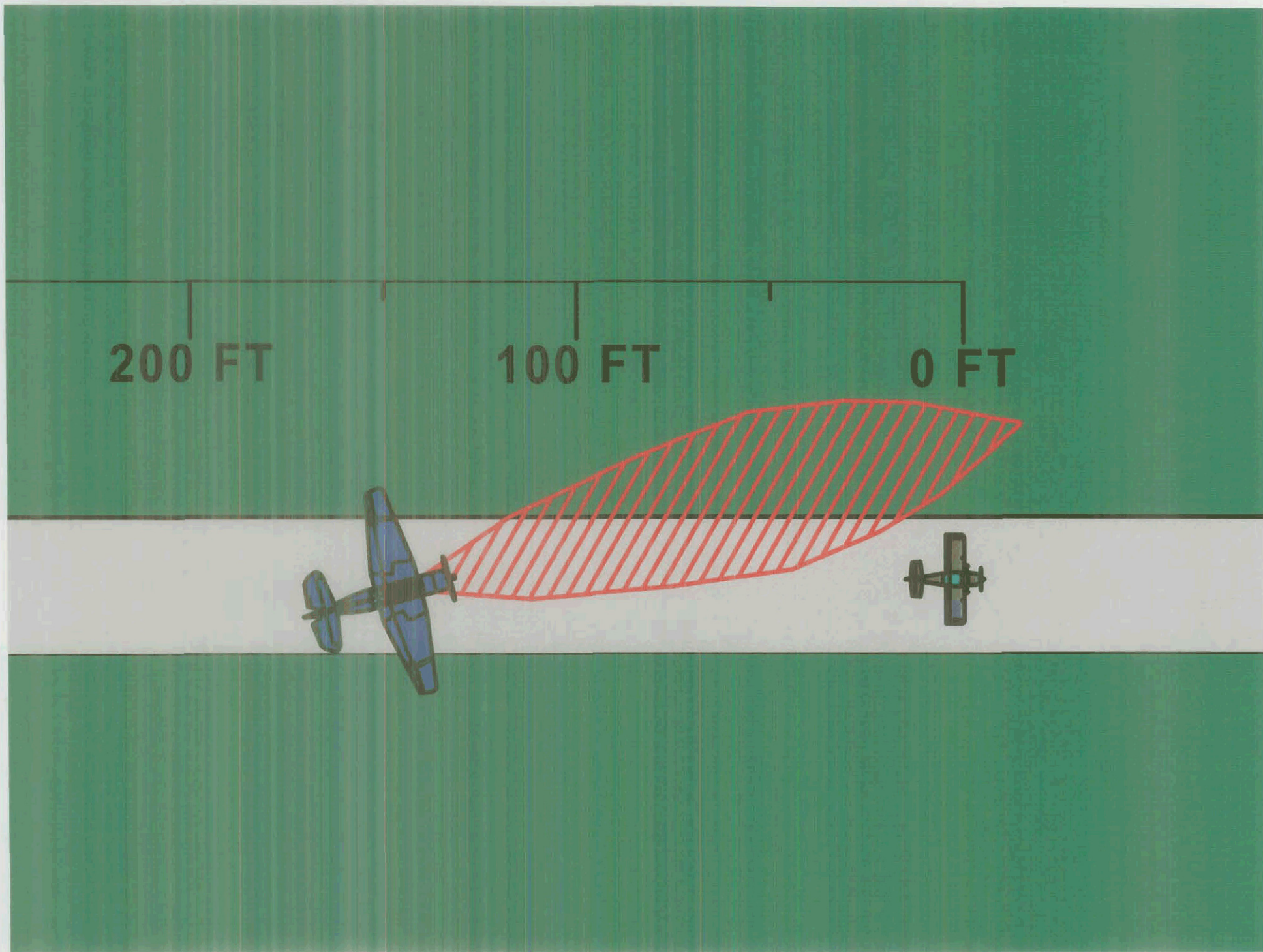

200 FT

100 FT

0 FT

