

**DOCKET No.: SA-519**  
**EXHIBIT No. 9B**

**NATIONAL TRANSPORTATION SAFETY BOARD**  
**WASHINGTON, D.C.**

**Systems 9 - Group Chairman Factual Report**  
**Appendix B**  
**MD-82 Diagrams and Schematics**

**(10 Pages)**

**American Airlines Flight 1420**  
**Little Rock, Arkansas**  
**June 1, 1999**

**DCA99MA060**

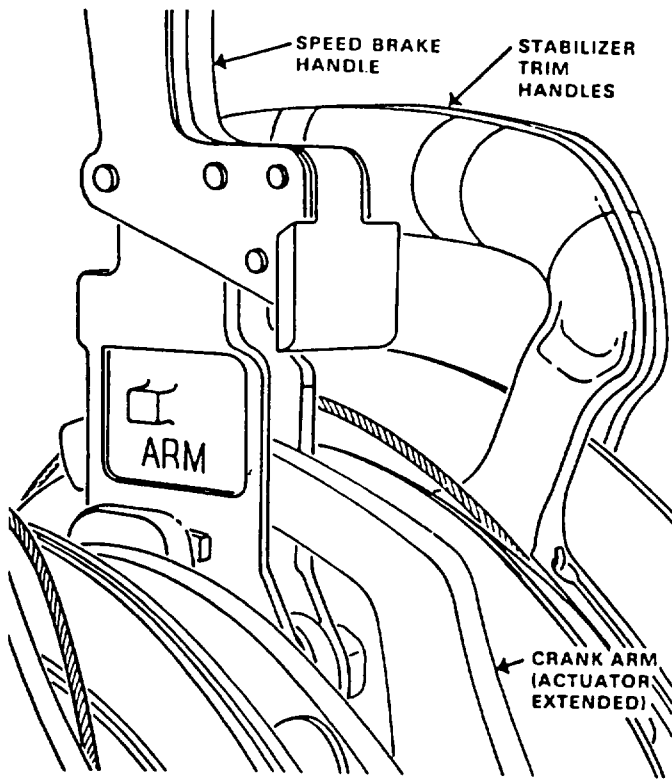

VIEW A (DISARMED)

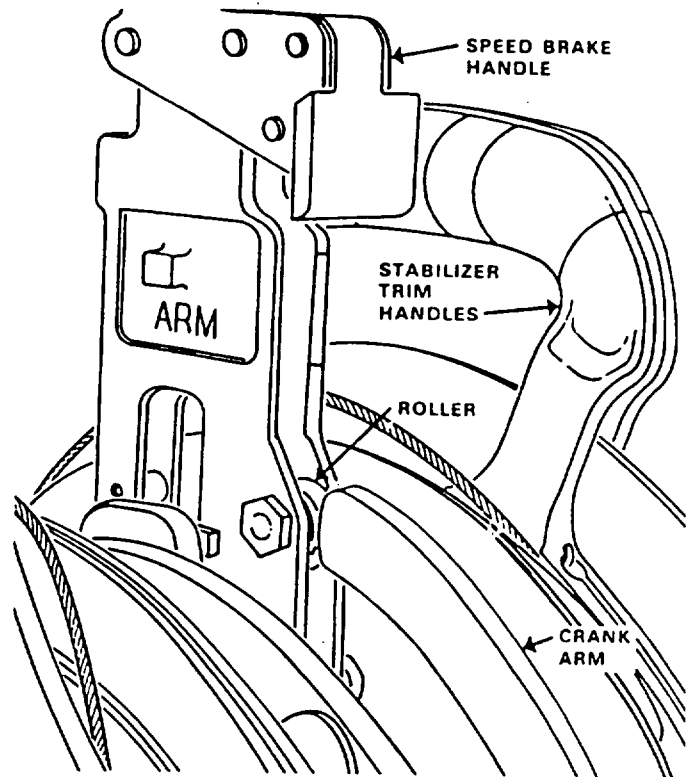

VIEW B (ARMED)

Positions of the Speed Brake Handle when Disarmed and Armed.

Reference: Packer, J.J., "MD-80 Autospoiler System", *Douglas Service Magazine*, Second Quarter 1983, page 8.

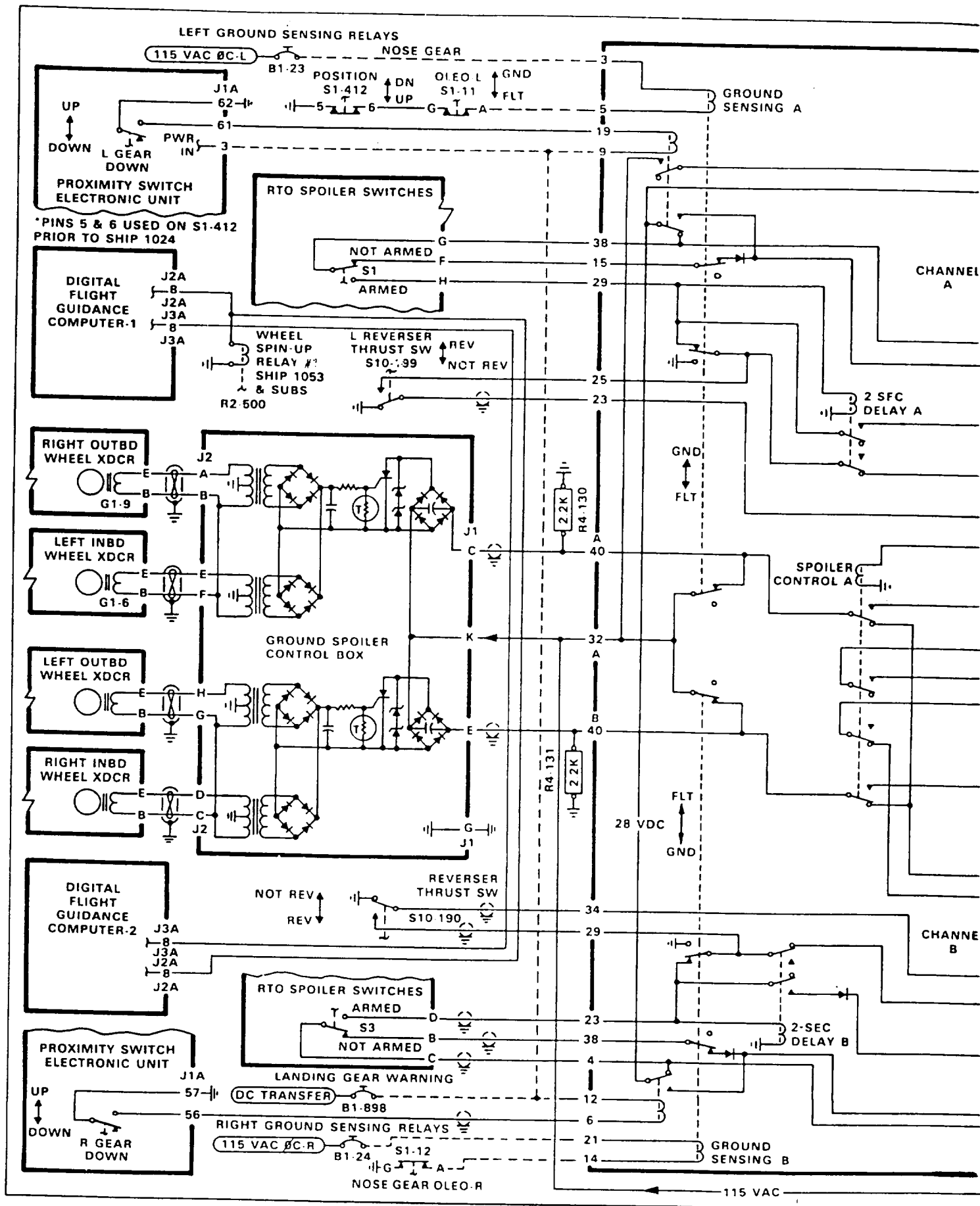
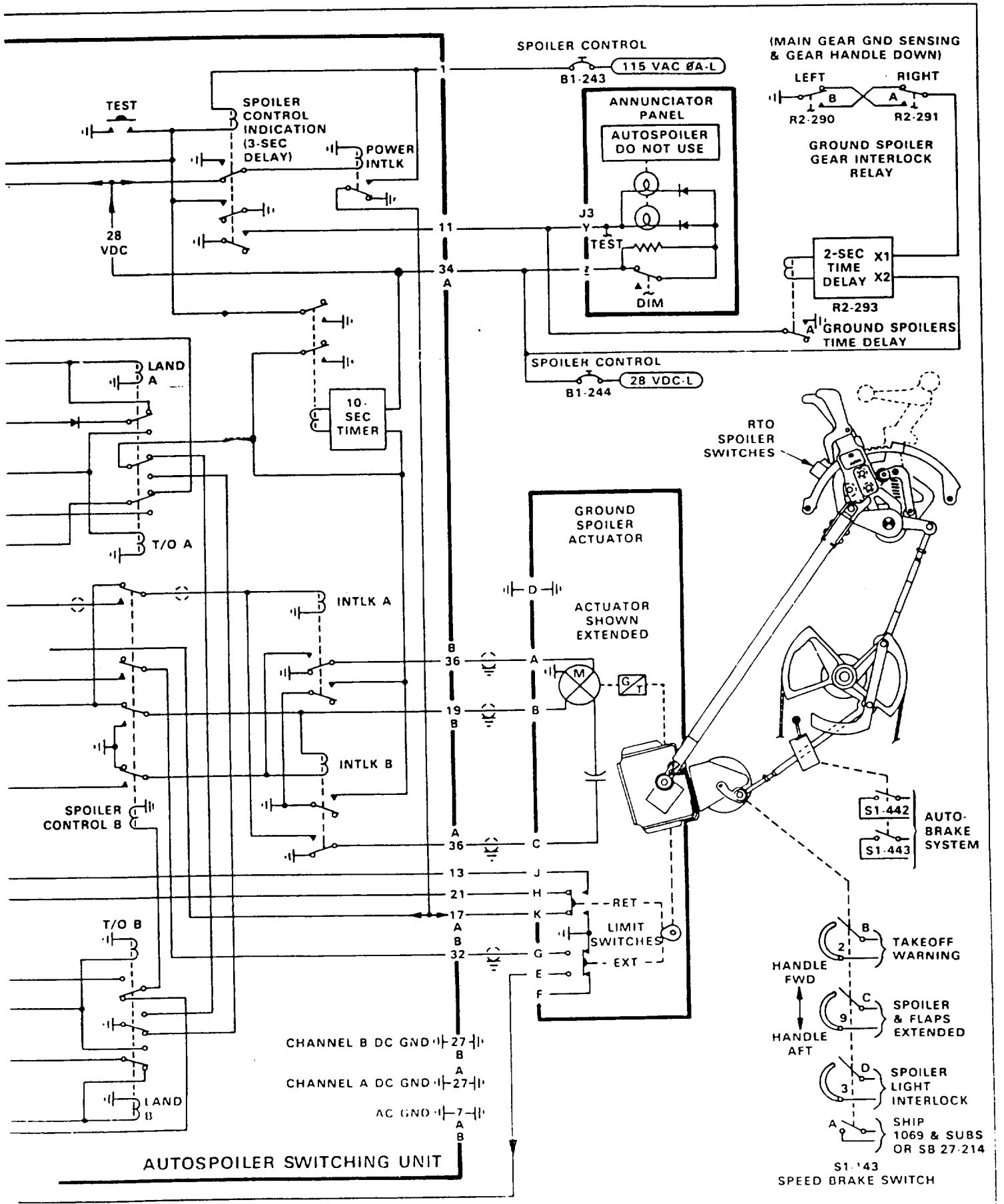
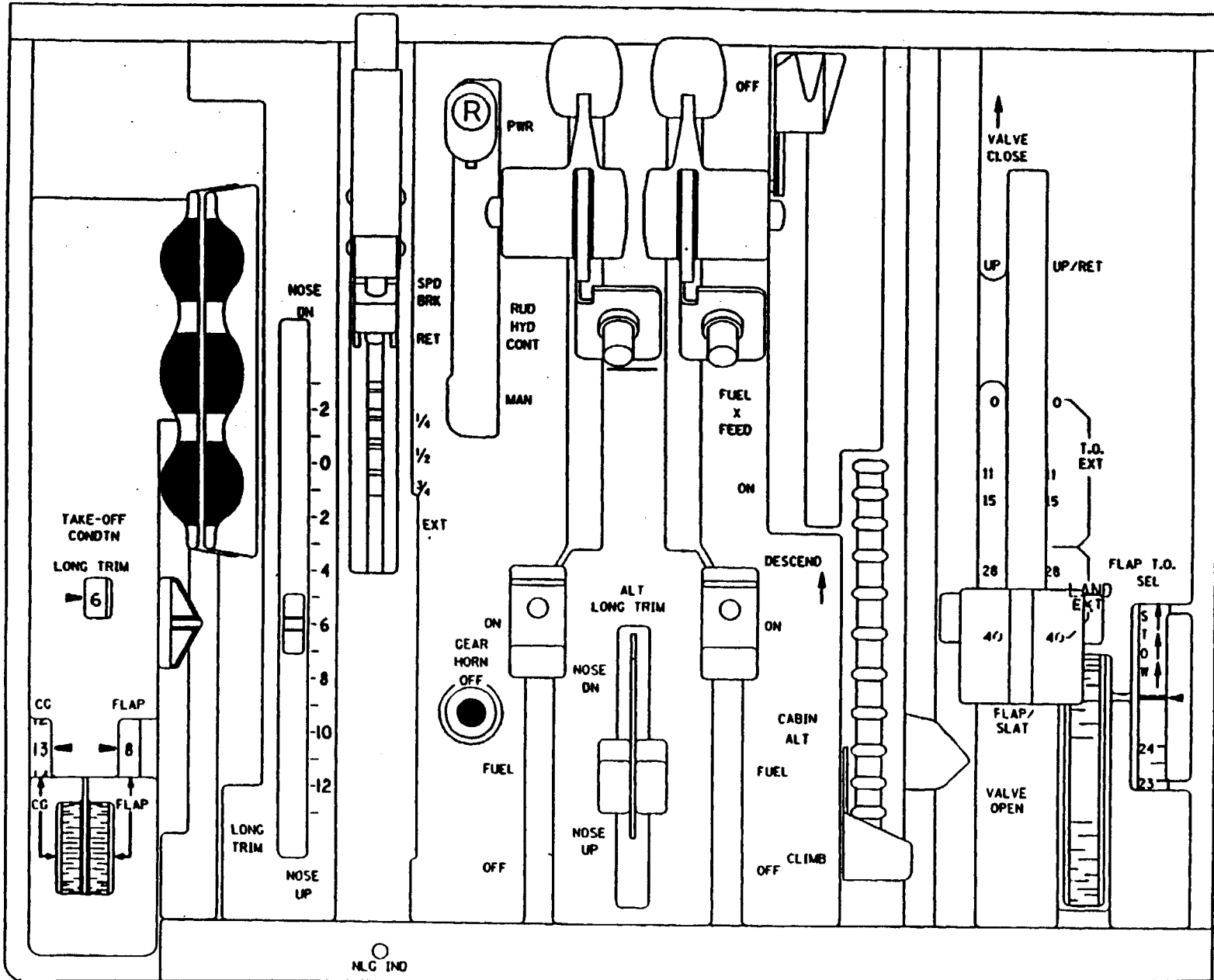
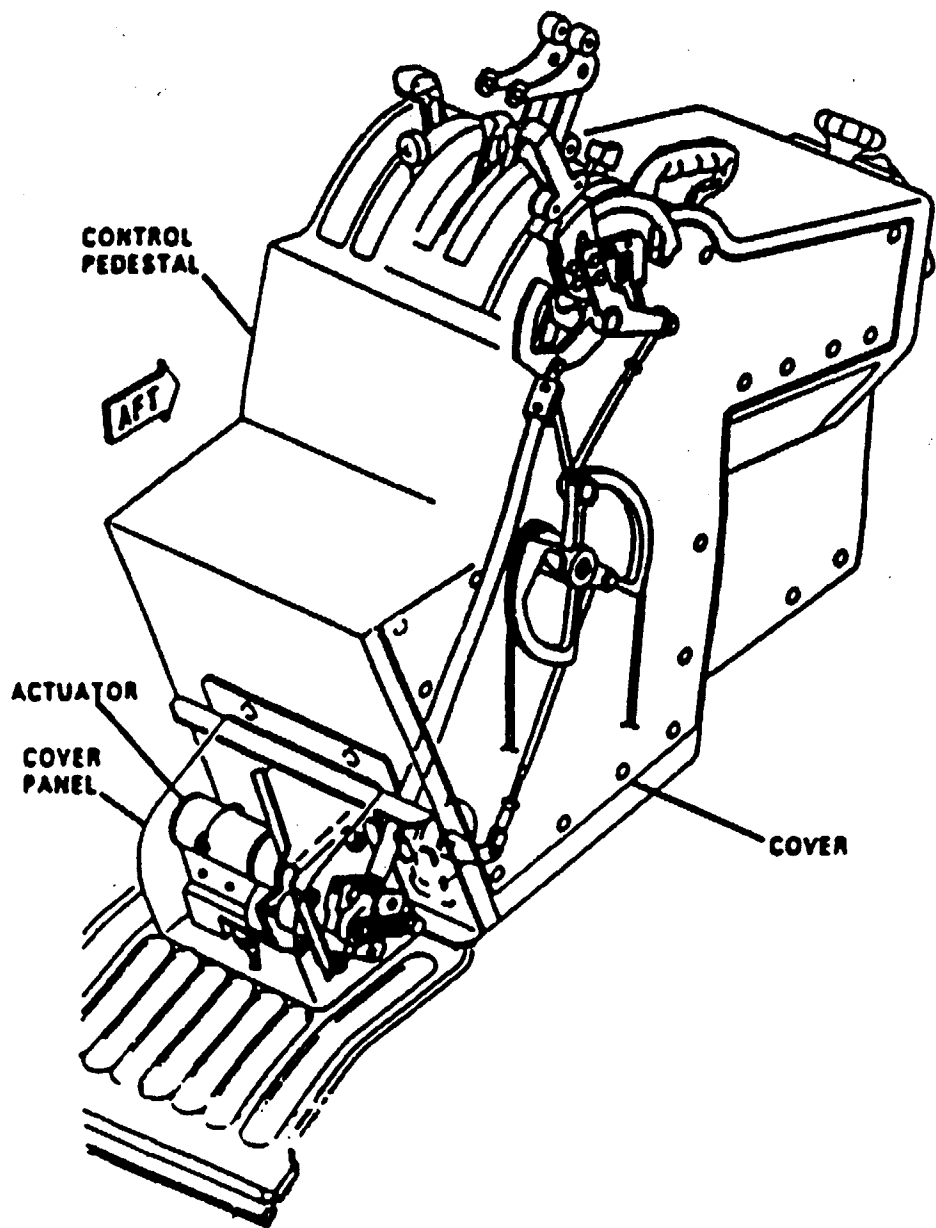
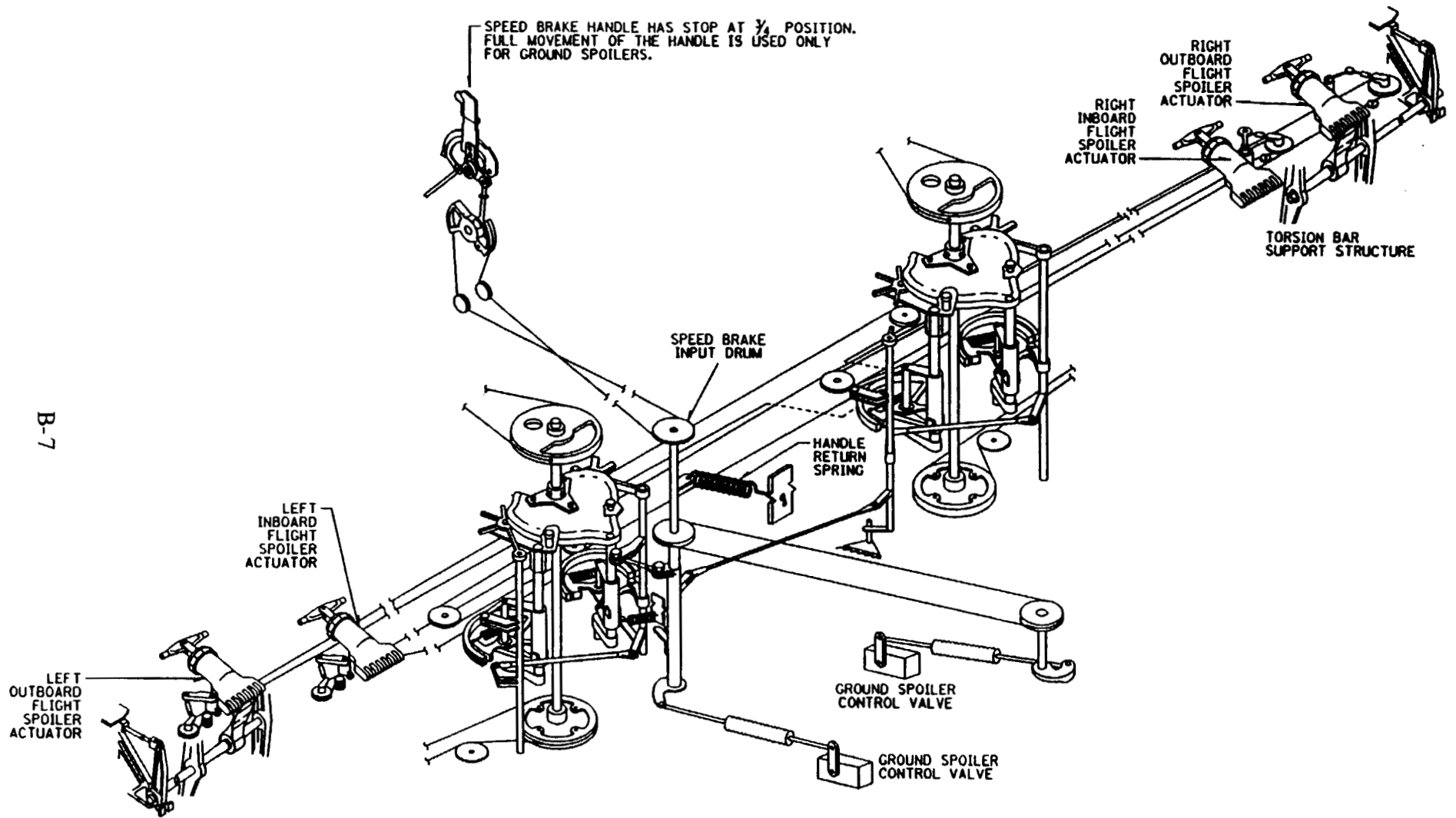

Figure 13. Autospoiler Switching Unit (3 Main Circuits)









B-7

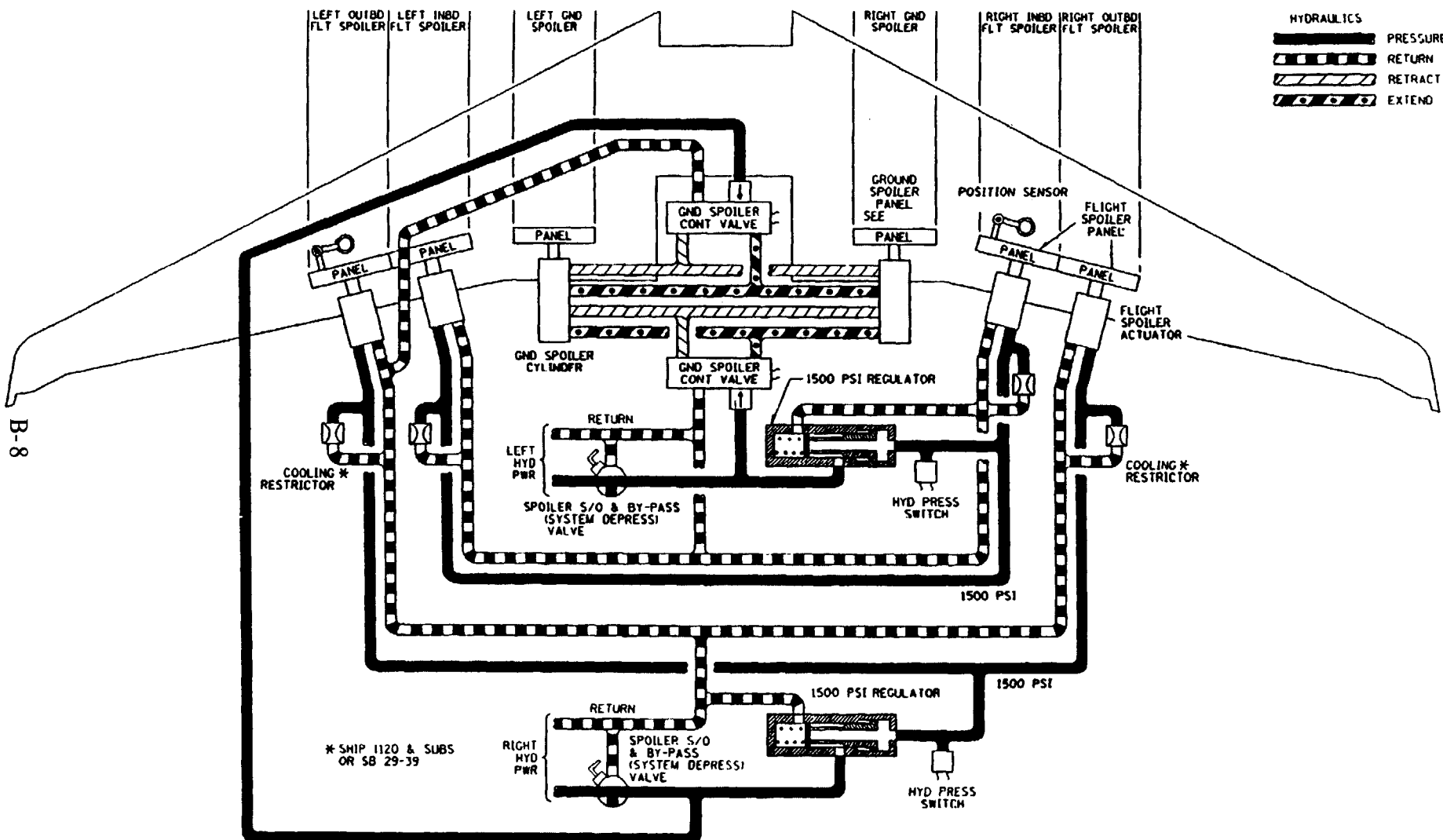

\* SHIP 1120 & SUBS  
OR SB 29-39

B-8



B-9

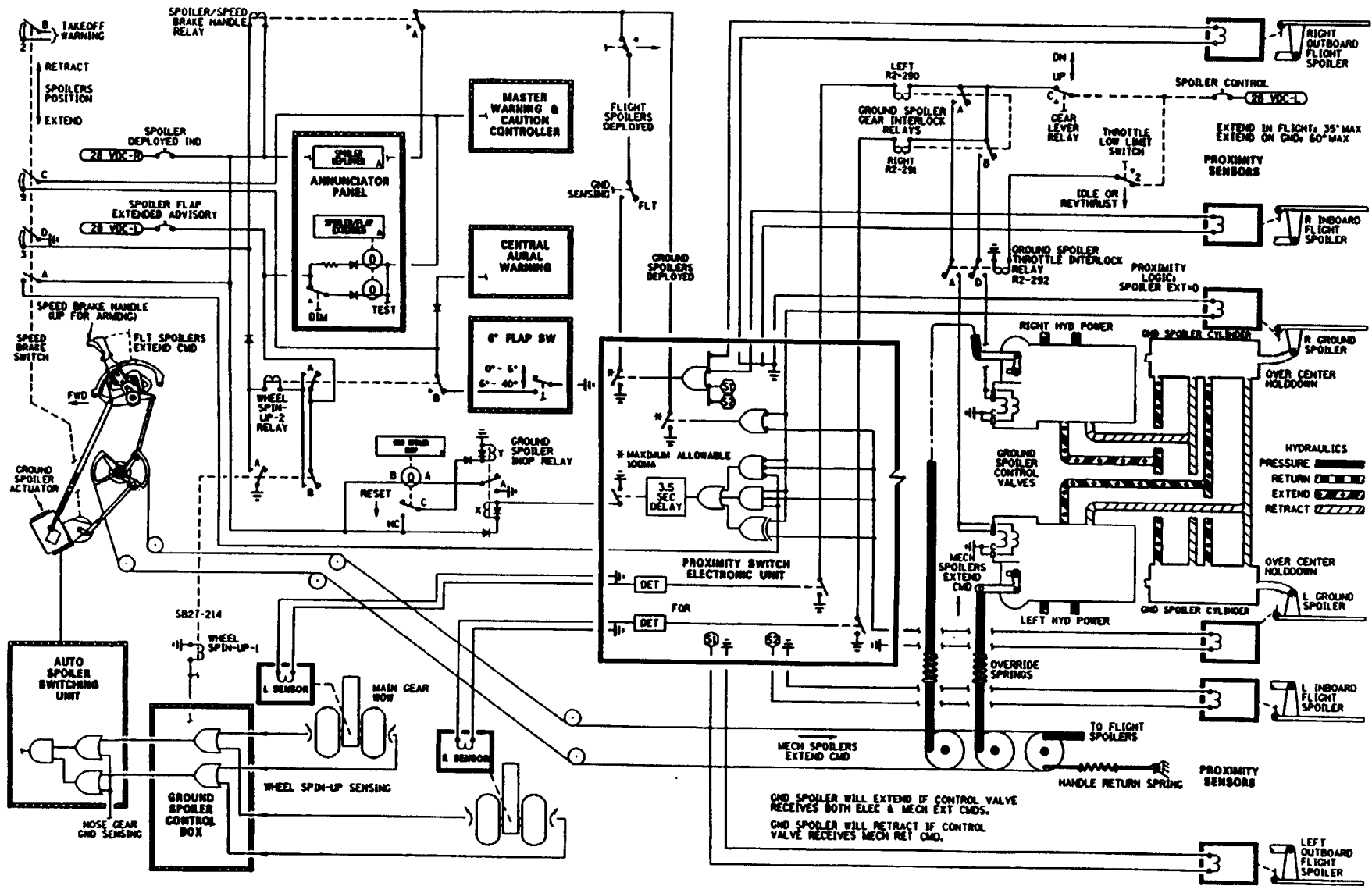

# DC-9 Super 80

## FLIGHT CREW OPERATING MANUAL

### HYDRAULICS - System Schematic

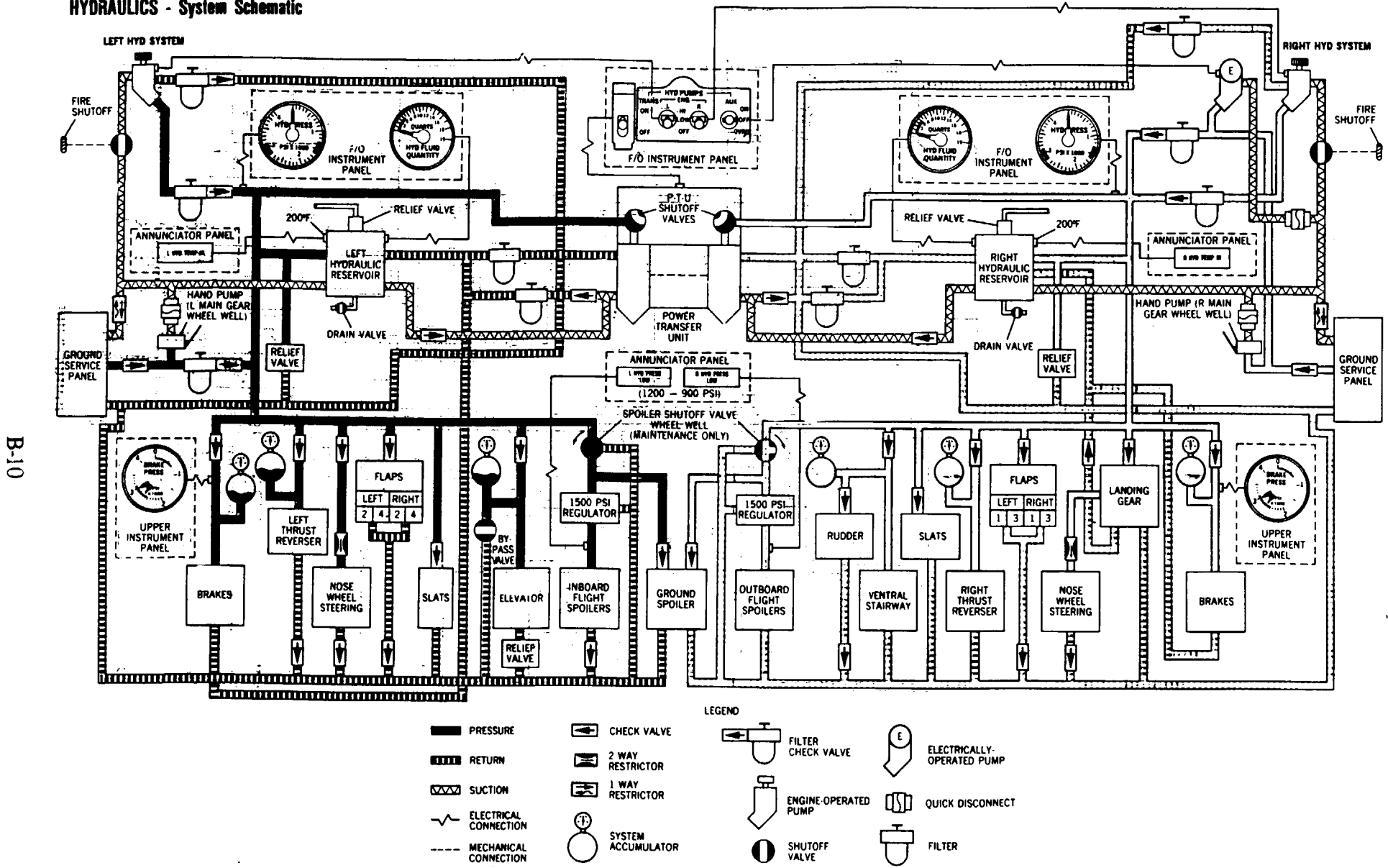

B-10