

APPENDIX B

Boeing 737 Diagrams

PLESSEY DYNAMICS CORPORATION
 OVERHAUL MANUAL WITH ILLUSTRATED PARTS LIST
 R5303 Series

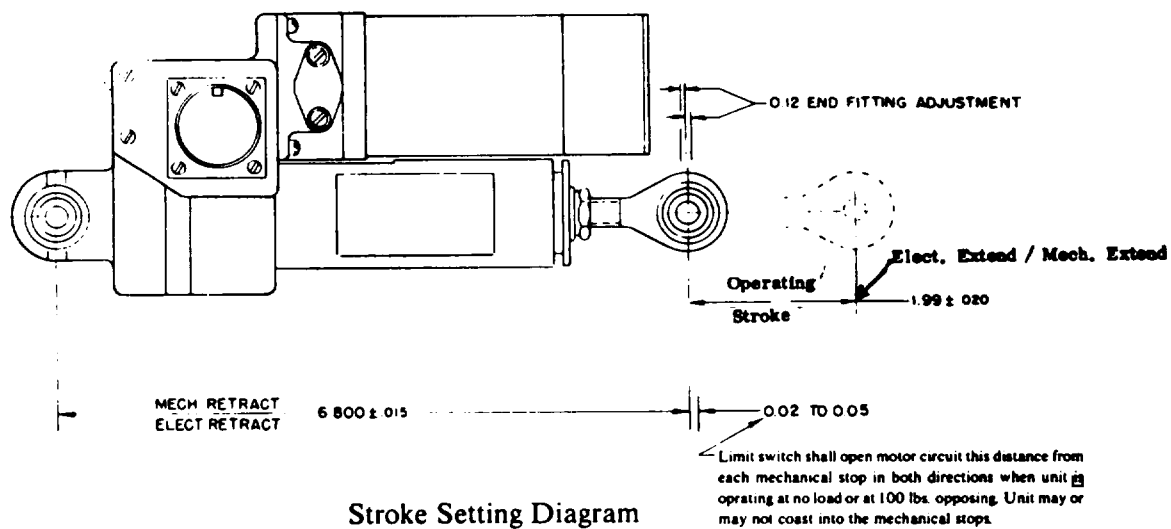

Stroke Setting Diagram
 Figure 702

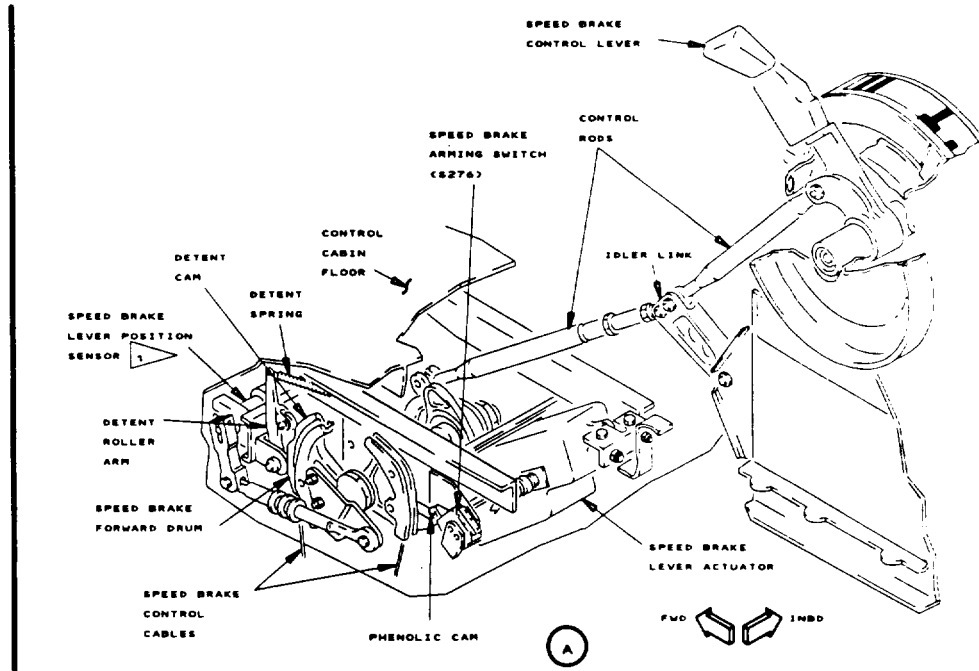

▲ AIRPLANES WITH SPEED BRAKE LEVER POSITION SENSOR

Speed Brake Control System Component Location
 Figure 2 (Sheet 2)

EFFECTIVITY	ALL
-------------	-----

02

27-62-00-0
 Page 4

11/15/88

BOEING 737-300/500 MAINTENANCE MANUAL

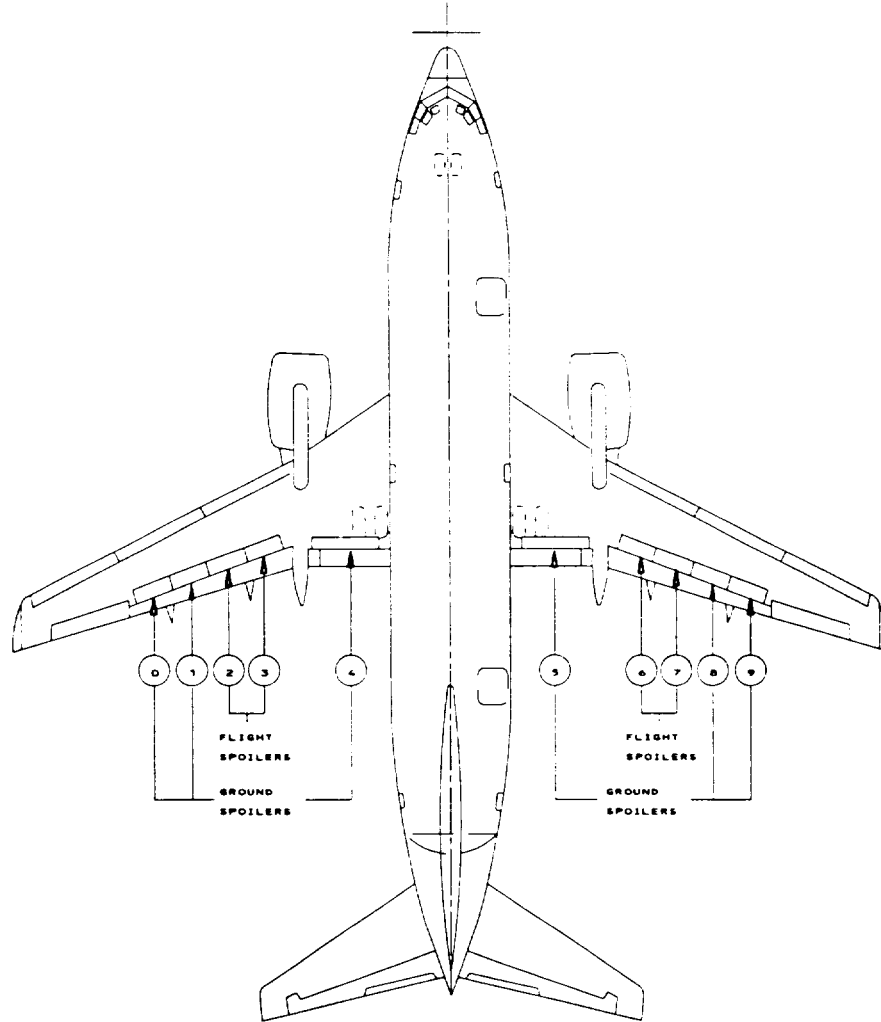

Spoiler Panel Identification
Figure 1

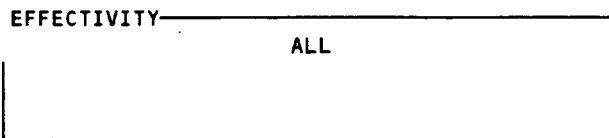

01

27-62-00-0
Page 2

02/20/84