

NATIONAL TRANSPORTATION SAFETY BOARD

Office of Aviation Safety
Washington, D.C. 20594

January 28, 2000

**ADDENDUM TO SYSTEMS GROUP CHAIRMAN FACTUAL REPORT,
AGING AIRCRAFT WIRE TESTING BY RAYTHEON, REPORT 2**

- A. **ACCIDENT** : DCA96MA070
- Location** : East Moriches, New York
- Date** : July 17, 1996
- Time** : 2031 Eastern Daylight Time
- Airplane** : Boeing 747-131, N93119
Operated as Trans World Airlines (TWA) flight 800

B. **SYSTEMS SUB-GROUP**

Chairman : Robert L. Swaim
National Transportation Safety Board
Washington, D.C.

C. **SUMMARY**

On July 17, 1996, at 2031 EDT, a Boeing 747-131, N93119, crashed into the Atlantic Ocean, about 8 miles south of East Moriches, New York, after taking off from John F. Kennedy International Airport (JFK). All 230 people aboard were killed. The airplane was being operated as a 14 Code of Federal Regulations (CFR) Part 121 flight to Charles De Gaulle International Airport (CDG), Paris, France, as Trans World Airlines (TWA) flight 800.

The Safety Board contracted Raytheon Systems Company to examine and develop a report about the condition of aged wiring that Safety Board personnel had removed from three transport airplanes. The wire type was similar to the general purpose ("hook-up") wire in the accident airplane and was insulated with a cross-linked extruded alkane-imide polymer with a modified -imide polymer topcoat and identified by Boeing as BMS13-42 or BMS13-42A. Each wire sample was taken from within a pressurized and environmentally protected fuselage area. The Raytheon report was attached to a Systems Group Chairman Factual Addendum of December 10, 1999.

While examining the bundles of wire for the first report, Raytheon found wires that were not insulated with the types of polymers that were identified by the Safety Board contract. The additional types of wire were insulated with single and dual layer crosslinked extruded modified ethylene tetrafluoroethylene (XL-ETFE), as well as crosslinked Polyalkene/Polyvinylidene fluoride (MIL-W-81044/9). Raytheon also found commonly used electrical connectors of various types, generally similar to MIL-C-26500.

The Safety Board extended the Raytheon contract to determine the properties of the additional wires and connectors, although the origin and installation dates for the additional types of wire were not known.¹ Raytheon tested the materials to the acceptance standards for new material. The report that Raytheon developed is attached.

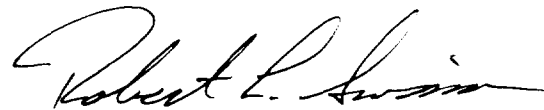

Robert L. Swaim
Systems Group Chairman

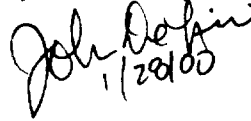

¹ Dr. Chris Smith of the Federal Aviation Administration found that the first production installations of XLETFE were in Douglas airplanes that had been manufactured in 1977.

Raytheon

Raytheon Systems Company
6125 East 21st Street
Indianapolis, IN 46219-2058

15 December 1999

Refer to: 99/CNE560/JK60/075

National Transportation Safety Board
490 L'Enfant Plaza, E., SW
Washington, DC 20594
Attn: Mr. Bob Swaim

Subject: SUBMITTAL OF SECOND TECHNICAL REPORT UNDER PURCHASE ORDER
NUMBER NTSB12-99-SP-0156

Raytheon is pleased to submit the subject technical report on Aging Wire Testing. We appreciate the opportunity to assist you in this study and hope that we can be of further assistance in the future.

This data is submitted for NTSB information. Please refer inquiries regarding this report to the author, Mr. Joe Kurek, at (317) 306-7029 or the Project Manager, Mr. Rex A. Beach, at (317) 306-7410. For information on contractual matters, please contact Ms. Kate Russell at (317) 306-7650.

Sincerely,



Rex A. Beach
RSC, Indianapolis Project Manager, Aircraft Wiring

Enclosure

bc: (w/o enclosure)

Rex Beach
Kate Russell

**Aging Aircraft Wire Testing
Report II**

Project Number 50-01-142

Technical Report Prepared for
National Transportation Safety Board (NTSB)

15 December 1999

Raytheon Systems Company
Training and Services Division
Indianapolis

Wiring and Qualification Group, CNE560

Prepared By: Joe C. Kurek
Joe Kurek, Staff Engineer

Kathy Lyons
Kathy Lyons, Senior Technical Support Engineer

Reviewed By: Jim Meiner
Jim Meiner, Senior Engineer

Released By: D. P. VanAlstine
David P. VanAlstine, Manager QPL Section

ABSTRACT

Wiring from three different retired commercial passenger aircraft was examined and tested to evaluate the integrity of the insulated wire. Several types of insulated wire were present. The most prevalent wire type was insulated with crosslinked extruded alkane-imide polymer with a modified -imide polymer topcoat, also commonly referred to as Poly-X insulated wire. The results of this testing was presented in the report Aging Aircraft Wire Testing Project Number 50-01-142 of 29 October 1999, reference (1). Subsequent to the Poly-X wire testing, three other wire types were examined and tested in much the same manner, using the respective test methods of the wire types to evaluate the condition of the wire. Single layer crosslinked extruded modified ethylene tetrafluoroethylene (XLETFE) similar to Boeing Material Specification BMS 13-48, dual layer extruded modified XLETFE per BMS 13-48, and crosslinked Polyalkene/polyvinylidene fluoride insulated wires per MIL-W-81044/9 were tested in this second part of the evaluation. In addition, connectors from several samples were evaluated to determine their condition. The wire and connectors were taken from generally benign areas of the aircraft, where the effects of environmental exposure would be minimized. The inspected wire samples exhibited contamination with a variety of materials, including dirt, lint, paint and lubricant residues, smoke residue, and metal filings. The degree of contamination of the wire samples varied by aircraft. A few wires were found with cracked or damaged insulation. Visually, the wire appeared to be in good condition. A few connectors exhibited areas of corrosion, although the general condition appeared to be satisfactory for operation.

The three types of insulated wire from the aircraft performed similarly during testing, with the exception of thermal aging. Test results showed the wire continued to be able to pass many of the performance requirements that new wire must pass, including mechanical and thermal tests. The single layer BMS 13-48 type wire was damaged, resulting in dielectric failures. The outer layer of the dual layer BMS 13-48 wire had become fairly rigid during the aging. The outer layer cracked, although the inner layer retained electrical integrity. The dual layer MIL-W-81044/9 wire also developed problems during testing. The outer layer also became rigid during the aging, but the wire failed completely following thermal aging of lifecycle. In comparison to the BMS 13-42 wire tested in reference (1), the BMS 13-48 wire appeared to be in better condition with greater potential for additional long-term service life, while the M81044/9 also appeared to be in better condition, but with little potential for significant additional service life.

The connectors from the three aircraft all exhibited varying degrees of deterioration, but the connectors all maintained electrical integrity during testing. The potential for maintenance on the connectors is decreasing as the grommets begin to harden, and as the ability to insert and remove contacts diminishes.

TABLE OF CONTENTS

<u>Section</u>	<u>Page</u>
1. BACKGROUND.....	1
2. DETAILS.....	1
2.1 Source Aircraft	
2.2 Wire Sample Source Locations	
2.3 Wire Sample Background	
2.4 Component Wire and Connector Descriptions	
2.4 Test Program Parameters	
3. TEST PROCEDURES AND RESULTS.....	6
3.1 Visual Examination.....	6
3.2 Mechanical and Electrical Tests	
3.2.1 Concentricity.....	8
3.2.2 Dielectric Test.....	8
3.2.3 Insulation Resistance.....	9
3.2.4 Insulation Tensile and Elongation.....	9
3.2.5 Notch Sensitivity.....	10
3.3 Thermal Tests	
3.3.1 Low Temperature (Cold Bend).....	12
3.3.2 Wrapback.....	12
3.4 Thermal Aging Tests	
3.4.1 Accelerated Aging.....	14
3.4.2 Life Cycle.....	14
3.5 Connector Tests	
3.5.1 Maintenance Aging.....	16
3.5.2 Dielectric Test.....	16
3.6 Discussion Summary.....	18
4. CONCLUSIONS.....	19
APPENDIX I: BMS 13-48 wire specification	
APPENDIX II: MIL-W-81044/9 wire specification	
APPENDIX III: MIL-C-26500 connector specification	
APPENDIX IV: Sample Photographs	
APPENDIX V: Photographs of sample problems	

1. BACKGROUND

To evaluate the condition of wiring in current commercial passenger aircraft, the National Transportation Safety Board (NTSB) established a program to investigate the electrical interconnection system and to characterize the condition of wiring in aircraft after long periods of service. The investigation has been prompted by a need to better understand the condition of wiring in aging commercial aircraft. The NTSB contracted Raytheon Systems Company (RSC), Indianapolis to evaluate aircraft wire removed from several recently retired aircraft. Three wire types, BMS 13-48 Rev A single and dual wall and MIL-W-81044/9, and several connectors were evaluated. The insulated wire was located on the same aircraft as the previously tested Poly-X insulated wire. These wire types are of similar age, although of different types as the majority of the wiring used on TWA Flight 800, a Boeing 747 model that is undergoing an accident investigation by the NTSB. Some of these additional wire types may have been present in other aircraft manufactured during this time period. The wire samples and connectors were subjected to performance tests that new wire or connectors was required to pass at the time of purchase. Based on the experience of this laboratory, performance test results are discussed, but it was beyond the scope of this project to perform failure analysis or in-depth study of wire failures.

2. DETAILS

2.1 SOURCE AIRCRAFT

Wire was removed from three different aircraft for testing. The wire samples were taken within two months of the retirement of each aircraft. Two of the aircraft were Boeing model 747 airplanes, and the third was a Douglas Corporation model DC-10. All three aircraft were reported to have been retired for economic reasons, and the operators of each asked not to be identified. None are known to have been involved in any major accidents. The aircraft were arbitrarily identified and will be referred to here as the DC-10, White 747, and European 747.

2.2 WIRE SAMPLE SOURCE LOCATIONS

The wire samples were prepared and shipped under the supervision of Safety Board Investigator Debbie Childress. The wire samples were removed from the aircraft, bagged and labeled to signify the originating location. The wire, along with cables, connectors, cable ties, overbraid, and other hardware was removed from wire bundles that had been routed through the different aircraft. The general areas of the aircraft are shown in Figures 1 – 3. No wire was received protected by overbraid, although some of the wire may have originated in protected bundles. No wire was submitted that would have been expected to see high levels of environmental exposure. Table 1 describes the locations in the aircraft from which the samples originated. The environmental conditions of each location are noted for the propensity of the wiring in that area to see elevated environmental conditions.

2.3 WIRE SAMPLE BACKGROUND

The component wire removed from the aircraft included several different types of wire. Wire manufactured to BMS 13-48A (crosslinked ethylene tetrafluoroethylene, XL-ETFE, insulated wire), MIL-W-81044/9 (crosslinked Polyalkene insulated wire), and unmarked wire of the XL-ETFE type were submitted, along with wire manufactured to BMS 13-42A, BMS 13-42B, and MIL-W-81044/16 (Poly-X type wire insulation.) The presence of different types of insulated wire may have depended on the system installations and any rework that may have occurred on a specific aircraft. No polytetrafluoroethylene (PTFE) insulated wire was submitted in any of the wire samples. The European

747 sample did not contain any other insulated wire than the BMS 13-42 type.

Figure 1: White 747 Sample Origination as Described by NTSB

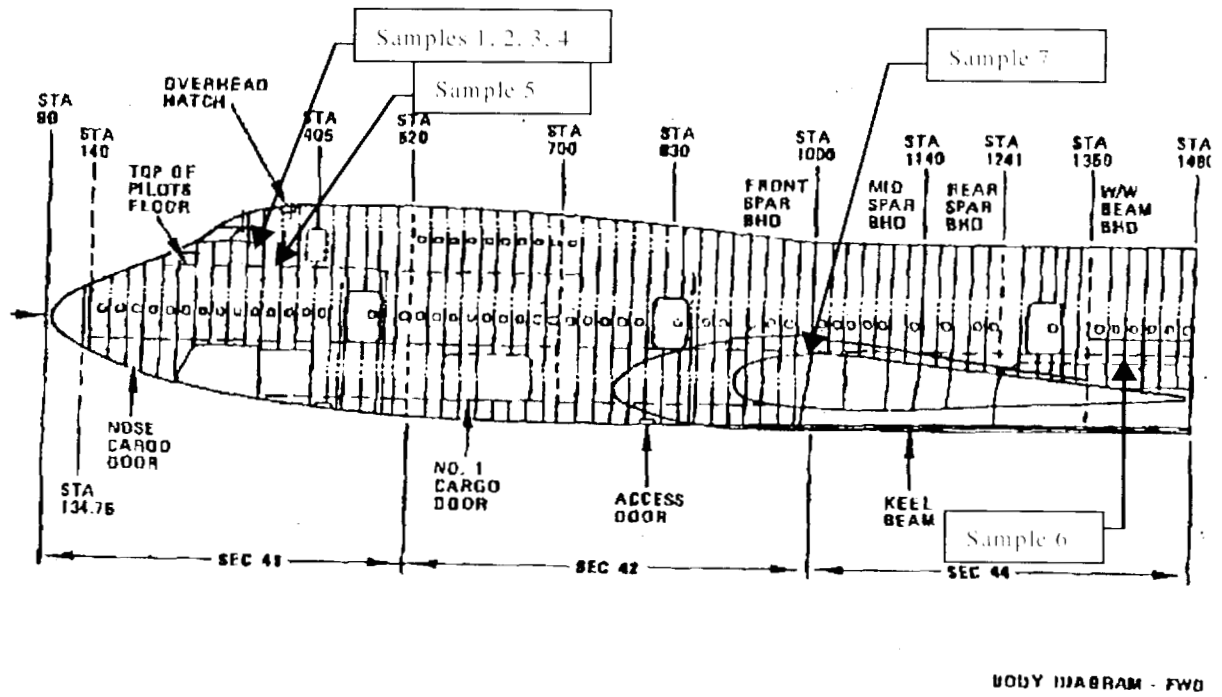

Figure 2: DC-10 Sample Origination as Described by NTSB

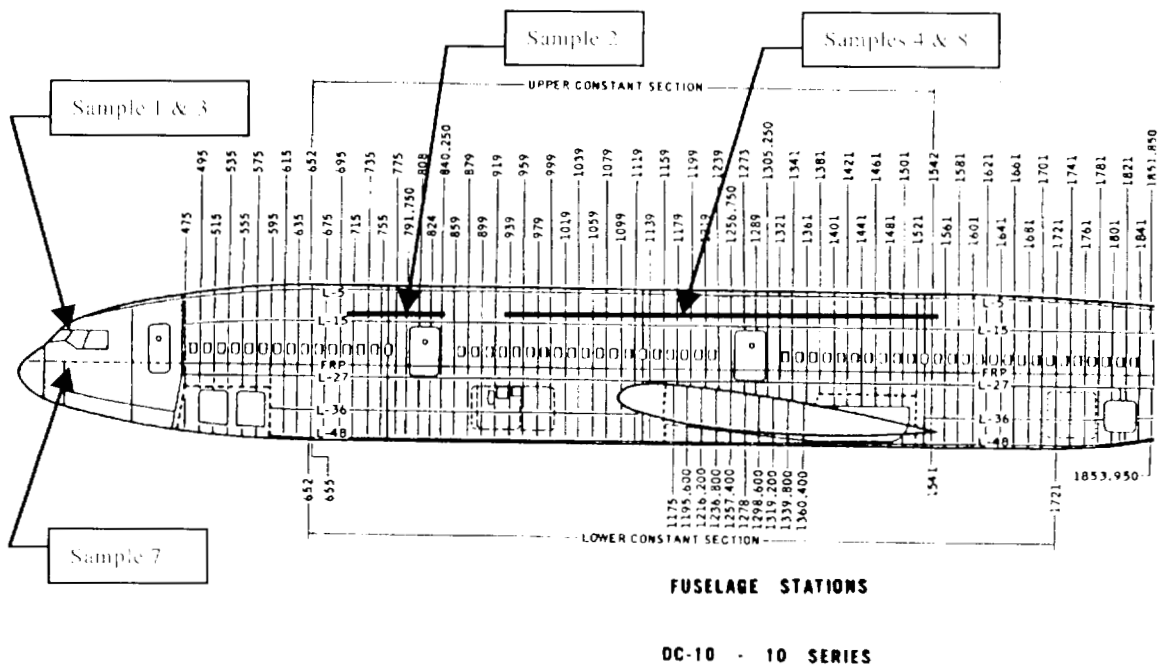

Figure 3: European 747 Sample Origination as Described by NTSB

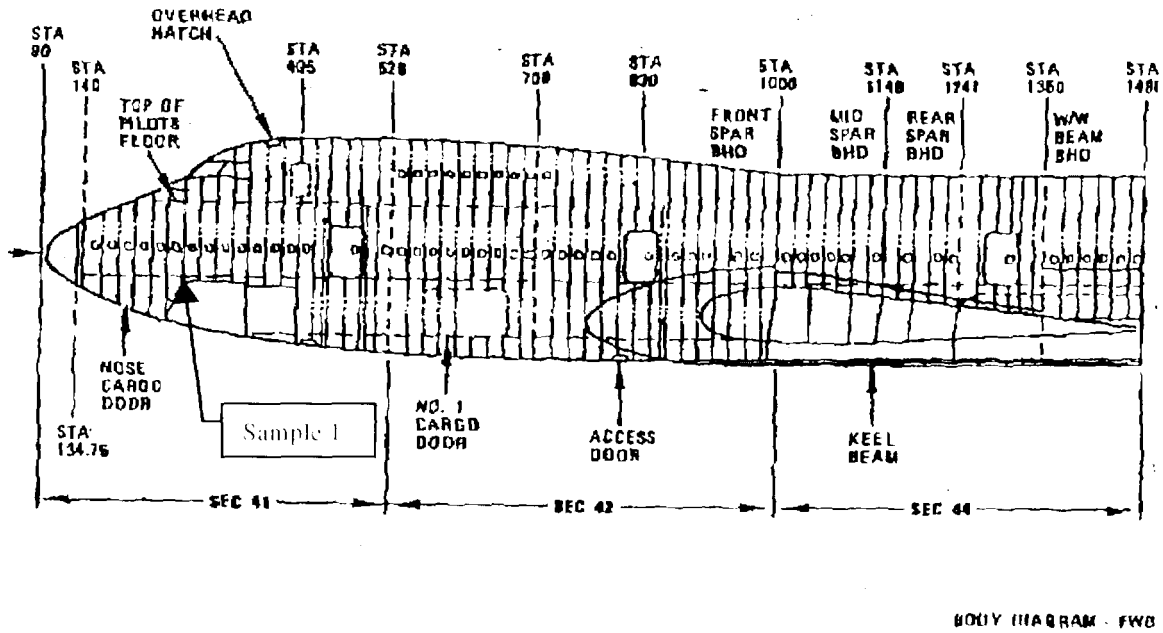

Table 1: Origin of Wire Samples Selected

<u>Aircraft</u>	<u>Sample</u>	<u>Origin of Wire</u>	<u>Potential Environmental Exposure</u>
White 747 SN: 199** Delivery: 1973	S1, S2, S3, S4	Flight Engineer's panel in cockpit	Possible UV (Ultraviolet) exposure
	S5	Station 380, right hand Side of flight crew exit door	
	S6	Station 1438, directly below floor panel of Seats 37 A, B, and C	Benign
	S7	Just forward of center fuel tank on the right hand side	
DC-10 SN: 465** Delivery: 1973	S1, S3	Cockpit overhead center panel	Hot, dry, no UV exposure
	S2	Station 770, a 12 foot section taken from above R2 door	Benign
	S4	Station 919 to Station 1239	
	S5	Not marked	Not Known
	S6	Not marked	
	S7	Underneath flooring, pilot's side yoke area	Benign
S8	Station 919 to Station 1570, overhead right hand side from R2 door towards rear of aircraft	Elevated temperature	
European 747 SN: 197** Delivery: 1970	S1 (All)	Forward cargo hold	Benign

2.4 COMPONENT WIRE AND CONNECTOR DESCRIPTIONS

The component wire specifications are included in Appendices I and II, and the connector specification is included in Appendix III. The following two general wire types are significantly different from BMS 13-42 and from each other. All samples appeared to be tin coated copper conductor insulated wire. The component connector specifications were varied, but all connectors appeared to be cadmium or nickel coated, or anodized aluminum bodies with backshells.

2.4.1 BMS 13-48 single and dual layer

BMS 13-48 is a fluoropolymer insulated wire. A layer of modified ethylene tetrafluoroethylene polymer is extruded onto the conductor and irradiated to crosslink the polymer. The single layer wire is extruded with a single layer of insulation, while the dual layer wire is extruded with two distinct layers. Wire without manufacturers' markings was present, and was determined by Fourier Transform Infrared (FTIR) spectroscopy to be of the same insulated wire type, but may not have been manufactured to the BMS requirements. The military versions of this wire construction are MIL-W-22759/32-/46. The nominal wall thickness is .006 inch for the single layer insulation and .010 inch for the total thickness of the dual layer insulation. This wire construction with tin coated conductor is rated at 150 °C maximum continuous service temperature, although with silver or nickel coated conductor it is rated at 200 °C. This wire construction is commonly used in aircraft and aerospace applications today. Many manufacturers are currently qualified to produce the military specification version, which is essentially identical to the current Boeing version. In the early 1970's, one manufacturer was qualified to produce the BMS 13-48 wire and the military version.

2.4.2 MIL-W-81044/9

Wire manufactured to MIL-W-81044/9 consists of a primary layer of crosslinked extruded polyalkene with a top layer of crosslinked extruded polyvinylidene fluoride. All wire is marked on the outer layer of insulation with the specification and manufacturer's cage code. The primary insulation is approximately .010 inch thick, and the top layer is .005 inch \pm .001 inch thick. This wire construction is rated at 150 °C maximum continuous service temperature. This specification remains active today. Two companies were qualified to produce this wire construction in the early 1970's.

2.4.3 MIL-C-26500

A variety of military and commercial connectors were submitted with the wiring samples from the three aircraft. All appeared to be cadmium or nickel coated, or hard anodized aluminum. The manufacturers and specifications of the connectors and backshells varied. Several connectors were marked MS24266 and MS27291, which are detail specification sheets from MIL-C-26500. Other connectors appeared to be fairly similar to these military connectors. The testing performed on the connectors is fairly common to other connector specifications. A large number of companies produced connectors of these types.

2.5 TEST PROGRAM PARAMETERS

The wire samples were first examined for general condition and the presence of anything abnormal. A testing regimen was designed that would indicate the condition of the insulated wire within a short time frame. Tests from the procurement specifications were performed on the wire and connectors. Certain tests were not performed if the aging of the wire was not expected to have an impact on the test results, or if insufficient wire was available. Testing on the component wire was performed per Boeing specification BMS 13-48C and MIL-W-81044/9, while connector tests were performed per MIL-C-

26500. In most cases the military and Boeing test procedures were very similar. Although the single layer XLPE/TFE insulated wire marked M48301D18 was not marked as a Boeing specification wire, the wire was tested to this specification for comparison purposes.

3. TEST PROCEDURES AND RESULTS

3.1 Visual Examination

Appendix III of reference (1) contains photographs of each of the wire samples submitted to RSC for testing. Bundles contained wires ranging from 10 to 24 gauges, although the majority of the wire was 18 and 22 gauge. The connectors were submitted along with the wire samples, and are marked accordingly. Photographs of the submitted connectors are included in Appendix IV. The connectors were all circular with approximately 5 to 55 sockets or pins.

Each submitted wire or connector sample was examined and photographed (Photo A1-A6). The wire samples were examined for various elements, including general condition, mechanical damage, electrical damage, thermal damage, contamination, and foreign debris. Degradation of the wire to some degree would not necessarily be considered unusual for aircraft wire, especially wire which had been in service for many years. Observations of each sample were detailed in Table 2. The samples of wire available in this phase were short, 2.5 to 20 feet in length. A few specimens did appear to be damaged over these limited lengths (Photo B1, B2). A few short lengths of another wire type (BMS 13-38 specification wire) were found with some of the connectors, but insufficient wire was available for testing.

The connectors were examined with similar criteria as the wire. A variety of connectors were submitted, including nickel coated, cadmium coated, and black anodized aluminum. Backshells sometimes included strain relief clamps and arms to support wire. Photographs were taken when appropriate, and are included in Appendix V. Observations noted from the physical examination of the connectors are in Table 2. A heavy brown film covered much of the components from the DC-10 aircraft (Photo B3, B4). These connectors also showed corrosion on the metal surfaces (Photo B5). Little corrosion was found on the metal connector and backshell bodies of connectors from the other aircraft. The grommets of the majority of connectors had not hardened significantly, although the connector grommets from the DC-10 appeared to have lost some resiliency and had begun to deteriorate (Photo B6). A large number of connectors contained many more cavities than there were wires (Photo B5, B7, B8). Usually the unused connector cavities were plugged with sealing plugs, but at times these additional cavities were not plugged (Photo B5, B9). Due to the disparity of wires to connector size, additional support was needed to prevent damage to the components and to the connection. Many of the backshells used strain reliefs with lacing ties, or brackets with tape as the support medium (Photo A3, A6). Some non-silicone type tapes were badly deteriorating in the backshells (Photo B10). Some fine metallic particles were observed on the grommet faces (Photo B11).

Certain observations, such as mechanical damage, lack of sealing plugs, tight tie wraps, and stress on the wires out of the backshells, could be potentially detrimental to the performance of the wiring. Items such as metal filings and gouges found in harnesses would affect any of the wire types to some degree. Mechanical damage was found throughout many of the samples submitted from the aircraft, but the XLFTEF and polyalkene/polyvinylidene fluoride insulated wires appeared to have fewer damaged areas than the Poly-X insulated wire. Submitted samples which contained no BMS 13-48 or M81044/9 type wire or connectors were not listed in Table 2.

Table 2: Visual Examination Results

<u>Sample</u>	<u>Area</u>	<u>Observations</u>
White 747	S1	Poly-X type wire and small amount of BMS 13-38 type wire. Connectors dirty with lint and dirt adhering to the back of the connector and wires. Some fine metallic particles on the grommet face. Grommets soft and elastic. Empty sockets plugged. No corrosion.
White 747	S4	XLETFE type wire. No damage observed. Three connectors of varying condition. One connector was clean, with empty sockets plugged. Second connector was a little dirty with empty sockets not plugged, and a third was very dirty and sticky with some paint overspray, but the empty sockets were plugged. Grommets all appeared in satisfactory condition.
White 747	S5	XLETFE wire present. One wire mangled and failed dielectric withstanding (Photo B2). The conductor on several wires contained blackened strands. Some connectors dirty. Most empty sockets were plugged. Grommets appeared in satisfactory condition. Several connectors were very large compared to the small number of wires accommodated. Many connectors had no strain relief.
DC-10	S2	Wire dirty with brown film and strong odor. M81044/9 type wire with no physical damage observed.
DC-10	S4	Heavy brown film with a strong odor covering wire. M81044/9 type wire with no physical damage observed.
DC-10	S6	Wire clean. Connectors somewhat dirty with a dried dark residue and some corrosion. Grommets appeared satisfactory.
DC-10	S7	Wire dirty, dusty, and slightly oily. Dual layer XLETFE present with no physical damage seen.
DC-10	S8	Brown film covered much of wire (Photo B3), along with a strong odor of cigarette smoke. Some areas were covered with more dirt or a heavier brown film than other areas. Fifty-foot harness held together by about 40 very tight nylon tie wraps. Single layer XLETFE insulated wire present with one instance of gouging (PhotoB1). Connectors very dirty with heavy brown film (Photo B4). Corrosion seen where the connector was heavily coated with the brown film. Wire at the connector contained cuts. Strain relief very tightly tied to the wire, deforming the grommet entries and possibly creating a poor seal. Grommets slightly hardened, with slight cracking. No sealing plugs present in empty sockets.
European 747	S1	Poly-X type wire. Connectors somewhat dirty. A few were lightly dusty, while others had a heavy dust coating. A few connectors exhibited some white paint overspray. Connectors not sticky, but some fine metal filings found in a few of the grommets. Otherwise the grommets appeared satisfactory. Most empty sockets plugged. Several connectors oversized for number of wires accommodated.

3.2 Mechanical and Electrical Tests

3.2.1 Concentricity

The concentricity test measures manufacturing accuracy and is quite important for an extruded insulation type wire. The proper dielectric properties of a wire are dependent on the ability of the insulation system to protect the conductor. Manufacturing problems may be encountered that reduce the thickness of the insulation at any one point, and will directly affect the voltage level that can breakdown the remaining insulation. In older wire, this test also becomes a check on the integrity of the insulation and any presence of cold flow or wire wear that may also decrease the effectiveness of the insulating properties.

Test specimens are carefully cross-sectioned from the wire sample with a sharp razor blade. The specimen is then held at a right angle to an optical measuring device, and the thickness of the insulation layers in relation to the conductor and overall sample geometry are evaluated. Concentricity of insulation is measured as a ratio of the thickest to the thinnest wall thickness in a specimen. New wire manufactured to these specifications required 70% minimum concentricity.

All specimens met the requirements of new wire. Results are provided in Table 3.

Table 3: Concentricity Results

<u>Samples</u>	<u>Area</u>	<u>Specimens</u>	<u>Concentricity (%)</u>	<u>Results</u>
DC-10	S4	M81044/9 - 22 gauge, Inner Layer Only	94%	Passed
DC-10	S4	M81044/9 - 22 gauge, Outer Layer Only	87%	Passed
DC-10	S8	M4830D18 - 18 gauge	77%	Passed
White 747	S5	W48A/02-8/1- 22 gauge	79%	Passed

3.2.2 Dielectric Test

The dielectric test employed was an electrical test commonly used to determine the integrity of wire insulation. It is often called a Dielectric Withstanding Voltage (DWV) test, or Wet Dielectric test. An electrical potential across the insulation will short if any area of the insulation is too weak to contain the electrical potential. This test measures the leakage current sensed by the ammeter.

The wire was submerged in a 5% salt water solution, and a potential applied across the insulation by connecting the positive lead to the conductor and the negative lead to a copper rod in the salt solution. A potential of 2500 volts at 60 hertz alternating current was applied for 5 minutes to test the wire specimens for insulation electrical integrity. Insulation failures were determined by a leakage current that exceeded 10 milliamps. The leakage current was not specified in either the military or Boeing specifications.

This test was used in conjunction with other tests as a proof test for insulation integrity. All wire was dielectric tested prior to using for other tests. Wires with damage (dual layer BMS 13-48A wire of White 747 Sample 5, and single layer XLETFE insulated wire from DC-10 Sample 8) failed dielectric withstanding test. Failures were also detected in two long lengths of single layer XLETFE wire from DC-10 Sample 8 (Photo B12) when the insulation resistance test was attempted. When used as a proof test following various tests, the results are listed with the applicable test.

3.2.3 Insulation Resistance

The insulation resistance is a measure of the electrical resistance that an insulation imparts between a conductor and ground. Greater electrical resistance provides better insulating properties. The presence of shorts, weak areas, or poor material quality of the insulation can lead to low values.

Wire specimens, as long as possible, were taken from the sample bundles and tested for the insulation resistance by immersion in a water bath with 0.5% anionic surfactant per the Boeing test method. After a four hour soak, 500 volts potential was applied across the wire and surfactant solution. Twenty-six feet of wire was required per the test specification, but this length was not available from any of the samples. The test results can be variable, and long specimen lengths are necessary to extrapolate values out to 1000 feet. Test values from shorter specimens may not be as accurate as from longer specimens. Values are usually given in ohms per thousand feet of wire. The minimum requirement for the insulation on new wire per the Boeing and military specifications were:

BMS 13-48C	2500 megohms (MΩ)/1000 ft. (single or dual layer XLPE/TFE) *
M22759/32	5000 MΩ/1000 ft. (single layer XLPE/TFE)
M22759/34	5000 MΩ/1000 ft. (dual layer XLPE/TFE) 24-10 gauge
M22759/34	3000 MΩ/1000 ft. (dual layer XLPE/TFE) 8-00 gauge
M81044/9	5000 MΩ/1000 ft.

* This requirement was raised to 5000 MΩ/1000 ft. in later revisions of the Boeing specification.

The results in Table 4 indicated that the wire specimens surpass the original requirements of the Boeing and military specifications. The White 747 specimen was too short to accurately measure the insulation resistance. Two specimens of the DC-10 Sample 8 wire failed dielectric during this test before a third specimen could actually be measured.

Table 4: Insulation Resistance Results

<u>Samples</u>	<u>Area</u>	<u>Specimen</u>	<u>Specimen Length</u>	<u>Resistance (MΩ/1000 ft.)</u>	<u>Results</u>
DC-10	S4	M81044/9 - 22 gauge	19.2 feet	30,670	Pass
DC-10	S8	M4830D18 – 18 gauge	26 feet	Dielectric Failure*	No measurement
DC-10	S8	M4830D18 – 18 gauge	15 feet	Dielectric Failure*	No measurement
DC-10	S8	M4830D18 – 18 gauge	15 feet	24,000	Pass
White 747	S5	W48A/02-8/1- 22 gauge	3.25 feet	3250	Pass

* Note – Dielectric failure resulted in inability to measure insulation resistance on wire specimen.

3.2.4 Insulation Tensile Strength and Elongation

As a material ages, the elasticity or strength may change dramatically. The molecular bonds of a material may weaken due to various mechanisms, such as hydrolysis, thermal breakdown, ultraviolet degradation, etc. This material degradation can often lead to a decrease in the ability to withstand physical stress. Tensile strength and elongation are two properties that are often used to characterize a material. For example, aging may cause a material to harden, the tensile strength to increase, and the elongation to decrease. Materials that harden may tend to crack and fall apart when moved or disturbed. The materials used for the wire insulation must continue to keep their properties over the service life of

the wire in order to meet the performance required of it. Disintegration of wire insulation is unacceptable in an aerospace environment.

Three inch slugs of insulation were removed from the wire. The specimens were tested to determine the tensile strength and elongation using a compression/tension machine with a 20 inch/minute jaw separation. Requirements on new M81044/9 wire were 150% minimum elongation to break and 2500 pounds per square inch (psi) minimum to break. Requirements for the BMS 13-48 specification were 50% minimum elongation to break and 5000 pounds per square inch (psi) minimum to break.

The results in Table 5 show that all wire insulations continued to meet the original specification requirements. The outer layer of the dual wall XLHTE was not able to withstand any appreciable force before failure; however, this is not a failure mode in this test.

Table 5: Insulation Tensile Strength and Elongation Results

<u>Samples</u>	<u>Area</u>	<u>Specimens*</u>	<u>Elongation</u>	<u>Tensile Strength</u>	<u>Results</u>	
			<u>(%) avg.</u>	<u>(psi), avg. peak</u>	<u>Elongation</u>	<u>Tensile Strength</u>
		M81044/9 wire	150% Requirement	2500 psi Requirement		
DC-10	S4	M81044/9 - 22 total insulation	437%	3713	Passed	Passed
		BMS 13-48 wire	50% Requirement	5000 psi Requirement		
DC-10	S8	M4830D18 - 18 gauge	218%	7558	Passed	Passed
White 747	S5	W48A/02-8/1-22 inner insulation	392%	6051	Passed	Passed

* Note – Three specimens were tested for each sample. Because it was impossible to separate the inner insulation from the outer insulation, the total insulation was pulled together; however, the outer insulation on the White 747 Sample 5 specimens broke immediately.

3.2.5 Notch Sensitivity

This test measures the ability of a wire insulation to resist the propagation of a nick or cut through the insulation layers to the conductor. One of the major drawbacks of some of the more rigid insulation systems is the tendency for the materials to crack, and for the cracking to continue all the way through to the conductor to create potential dielectric failure sites. There are several ways in which wire manufacturers have addressed this problem. One is to use materials that do not exhibit the tendency to propagate cracks. Another is to use more than one layer of material so that if one layer develops a crack or is nicked, another layer will retain its integrity.

A blade that protrudes a certain dimension out of the fixture was used. The insulation of the wire specimen was scored to that depth using the fixture blade, then physically stressed by wrapping 360° around a 1.0 inch mandrel with the notch on the outside of the bend to induce propagation of the notch. A 2500 volt dielectric test in a 5% salt water solution was performed to verify the integrity of the insulation. The Boeing specification required a .004 inch notch depth. This test was not a requirement in the military specification.

As shown in Table 6, all samples tested passed the requirements by maintaining electrical integrity during the dielectric voltage test.

Table 6: Notch Sensitivity Results

<u>Samples</u>	<u>Area</u>	<u>Specimen</u>	<u>Results, Dielectric</u>
DC-10	S4	M81044/9 - 22 gauge	Passed
DC-10	S8	M4830D18 - 18 gauge	Passed
White 747	S5	W48/02-8/1 - 22 gauge	Passed

3.3 Thermal Tests

3.3.1 Low Temperature (Cold Bend)

In an aerospace environment, the temperatures experienced by the aircraft quickly reach -65°C at altitude. Wire must be able to retain some physical performance abilities due to the physical stress that occurs in flight at low temperatures. Within the passenger cabin and cockpit, temperatures are regulated, but outside of these areas, where much of the wire in a commercial aircraft is located, the temperatures reach extremes. Many polymeric materials undergo thermomechanical transition at subambient temperatures, and become hard and brittle. Aerospace wire is expected to retain physical and electrical integrity through mechanical and electrical stress at the temperature extremes.

Wire specimens were cooled to -65°C with weights attached, wrapped around a mandrel at the cold temperature, and then visually checked for insulation cracking. In addition to this, the military specification MIL-W-81044 continued with a wet dielectric test in a 5% salt water solution to prove the insulation integrity. M81044/9-22 gauge wire was weighted with 3 pounds and wrapped around a 1 inch mandrel. BMS 13-48 18 gauge and 22 gauge sample fixtures were not defined, but the 20 gauge wire was weighted with 4 pounds and wrapped around a 1 inch mandrel. The XLETFE insulated specimens were tested to the revised specification parameters as shown below. This deviation created more stress due to the smaller mandrel diameter and less stress due to the lower weight. This difference is not expected to change the final results of the test.

As shown in Table 7, the outer insulation of both of the dual wall samples failed the bend test by cracking (Photos B13-B15), yet the inner insulation layers protected the specimens from electrical failure. The single layer insulated wire did not exhibit cracking of the insulation. All specimens passed the final wet dielectric withstanding voltage test. This test does not address long duration service stress such as vibration at cold temperatures.

Table 7: Low Temperature Cold Bend Results

<u>Samples</u>	<u>Area</u>	<u>Specimen (number of specimens tested)</u>	<u>Mandrel Diameter</u>	<u>Weights Each end</u>	<u>Results, Visual</u>	<u>Results, Dielectric</u>
DC-10	S4	M81044/9 - 22 gauge (3)	1.0 in	3 lb.	2 cracked outer insulation	3 passed
DC-10	S8	M4830D18 - 18 gauge (2)	.25 in	1 lb.	No Cracks	2 passed
White 747	S5	W48A/02-8/1 - 22 gauge (3)	.25 in	.75 lb.	3 Cracked outer Insulation	3 passed

3.3.5 Wrapback

The wrap test evaluates the ability of wire to withstand thermal stress while under mechanical stress. The test is short term, but the high mechanical stress during the thermal exposure can reveal weaknesses in the insulation and susceptibility of the insulation to cracking. The wrapback variant of the wrap test uses the wire itself as the mandrel, so that the bend is extremely small and tight.

Twelve inch specimens were wrapped tightly around themselves for a minimum of four close turns. The XLETFE specimens were hung in an oven at 250°C for 7 hours, while the M81044/9 specimens were at room temperature. After oven exposure, the specimens were inspected for cracking of the insulation. The BMS 13-48 specification required insulation to remain intact and not crack following thermal exposure, and no dielectric failures were allowed. The military specification M81044/9 required

insulation to remain intact with no cracking. A final wet dielectric test was not required with this wire construction, nor is it required with the MIL-W-22759 military version of the XLETFE insulated wire.

None of the specimens exhibited cracking. One specimen produced a wet dielectric failure as shown in Table 8. This may indicate that the insulation weakened during the thermal exposure.

Table 8: Wrapback Results

<u>Samples</u>	<u>Area</u>	<u>Specimen</u>	<u>Number of Specimens</u>	<u>Results, Visual</u>	<u>Results, Dielectric</u>
DC-10	S4	M81044/9 – 22 gauge	3	No Cracks	Not Required
DC-10	S8	M4830D18 – 18 gauge	3	No Cracks	2/3 Pass *
White 747	S5	W48A/02-8/1- 22 gauge	3	No Cracks	Pass

* Note – The failure occurred near the edge where the strippers may have damaged the insulation while stripping the end of the specimen.

3.4 Thermal Aging Tests

3.4.1 Accelerated Aging

The accelerated aging test is used to evaluate a wire's ability to withstand a higher temperature under mechanical stress for a short period of time. Wire insulation is expected to survive short-term tests to temperatures above the temperature rating of the insulation. This assumes that the test temperatures are below the melt temperatures of the insulating materials for thermoplastic insulations. This test, sometimes called crosslink proof, is also used to determine if the insulation of a wire has been converted to a thermoset material by polymer crosslinking. For crosslink proof, a temperature above the melt point of the non-crosslinked material is selected. In this case, the insulations were crosslinked materials.

Specimens were hung over a mandrel with weights attached to impart physical stress on the insulation, then placed in an air circulating oven at temperature. BMS 13-48 required 250° C for 7 hours. M81044/9 required 300° C for 6 hours. Following the heat exposure, the specimens were bent around a mandrel and proof tested with a dielectric withstanding voltage in a 5% salt water solution. New wire is expected to pass the dielectric test following high temperature exposure. Insulation and conductor degradation is allowed provided the electrical integrity is maintained. BMS 13-48 also required that the concentricity not decrease to below 40%.

As shown in Table 13, no specimens cracked during the thermal exposure or bend test, and all specimens passed the dielectric withstanding test.

Table 13: Accelerated Aging Results

<u>Samples</u>	<u>Area</u>	<u>Specimen, (number of specimens tested)</u>	<u>Mandrel Diameter</u>	<u>Weights Each end</u>	<u>Results, Visual</u>	<u>Results, Dielectric</u>
DC-10	S4	M81044/9 - 22 gauge (3)	.75 in	1.5 lb.	No Cracking of Insulation, print legible	Passed
DC-10	S8	M4830D18 - 18 gauge (3)	.75 in	1.5 lb.	No Cracking of Insulation	Passed
White 747	S5	W48A/02-8/1 - 22 gauge (3)	.25 in	.75 lb.	No Cracking of Insulation	Passed

3.4.2 Life Cycle

The life cycle test is similar and complementary to the accelerated aging test. Samples are exposed to elevated temperatures under mechanical stress, with temperatures lower than for accelerated aging, but for a longer exposure time. This test is used to determine the ability of a wire to withstand temperatures above the temperature rating of the insulation for an extended period of time.

Twenty-four inch specimens were hung over an appropriate mandrel with corresponding weights on each end (determined by the wire size) and suspended in an air-circulating oven at 200° C for 168 hours. Samples tested per BMS 13-48 are cycled 8 times, with each cycle 15 hours at 200° C then cooled to room temperature for 6 hours. After full thermal exposure, the specimens are bent around a mandrel and proofed by a dielectric withstanding test in a 5% salt water solution. New wire would be expected to pass this test with no failures, legible marking, intact insulation, and without pitting of the conductor. Mandrels and weights for the 18 and 22 gauge wires were not defined in BMS 13-48, but the 20 gauge wire was weighted with 4 pounds and wrapped around a 1 inch mandrel. The BMS 13-48 type insulated

specimens were tested to the revised specification parameters as shown below. This deviation created more stress due to the smaller mandrel diameter and less stress due to the lower weight. This difference is not expected to change the final results of the test.

As shown in Table 14, all three samples passed the bend test. The M81044/9 specimens all failed the final wet dielectric withstanding test (Photo B16), while the BMS 13-48 type insulated specimens passed. Various aircraft conditions, including shock, constant vibration, abrasion, ultraviolet radiation, thermal cycling, moisture, and fluid exposure, all affect the life of a wire. This test combined the high heat, to accelerate the thermal exposure based on the Arrhenius principle, as well as static stress on the insulation while hanging with weights and dynamic stress during the bend test. Results of this test indicated the type of thermal life that the wire may continue to exhibit.

Table 14: Lifecycle Results

<u>Samples</u>	<u>Area</u>	<u>Specimen, (number of specimens tested)</u>	<u>Mandrel Diameter</u>	<u>Weights Each end</u>	<u>Results, Bend Test</u>	<u>Results, Dielectric</u>
DC-10	S4	M81044/9 - 22 gauge (3)	.75 in	1.5 lb.	No Cracking	3 Failed
DC-10	S8	M4830D18 - 18 gauge (2)	.25 in	.75 lb.	No Cracking	2 Passed
White 747	S5	W48A/02-8/1 - 22 gauge (2)	.25 in	.75 lb.	No Cracking	2 Passed

3.5 Connector Tests

3.5.1 Maintenance Aging

Connectors must be durable enough to allow for maintenance on the contacts, insertion of new wires and removal of old, while maintaining the ability to secure the pins and sockets during connector use and continue to provide proper environmental sealing. Maintenance aging provided a brief look at the connector's ability to survive the insertion and removal of contacts over many cycles without damaging the grommet, and to continue to secure contacts, similar to what would be experienced during long term maintenance. Poor quality grommets may begin to crumble, and poorly sized or damaged connectors may not provide proper contact retention forces. Following the cycling, the connector contacts must continue to meet electrical integrity.

Within a given connector, a number of contacts were removed and inserted using proper insertion/removal tools. For this test program, an Astro M81969/17-03 insertion tool, and an Astro M81969/19-06 removal tool was used. Random contacts, including at the connector edges and center to be representative of the whole connector, were inserted and removed ten times, and the first and tenth were measured to check whether the contact retention and insertion forces were within the specification requirements. A MIL-C-26500 specification connector must meet the requirement for the insertion force of a single contact to not exceed 15 pounds, while the removal force of a single contact must not exceed 10 pounds. Since each of the connectors required unique insertion and removal force requirements, and each of these was not known, this test was used as a qualitative test, and any unusual forces required to insert or remove contacts were noted as observations. The dielectric integrity was then tested for the cycled contacts with a dry withstanding voltage of 1500 volts for one minute between adjacent contacts or between edge contacts and the connector body (see 3.5.2).

The testing results of the connectors from the three aircraft are summarized in Table 15. Several connectors failed, while others continued to pass the maintenance aging and dielectric withstanding test following the maintenance aging. The grommets of the DC-10 began to crumble, while the connectors began to lose the ability to have contacts removed, inserted, or retained. The grommets on several of the DC-10 connectors appeared to have lost some of their elasticity and have become deformed, possibly losing some of the sealing capabilities.

3.5.2 Dielectric Test

The dielectric integrity of the connector and contacts were determined using a dielectric withstanding voltage on an unmated connector in a dry environment. An applied potential will continue to hold provided there is sufficient dielectric between the two electrodes. The dielectric test was used to prove the connector can operate safely at its rated voltage and withstand higher voltages for a short period of time. Breakdown of the grommet or other materials, or contamination may lead to electrical shorts and the inability for the electrodes to hold the electrical potential. Thermal aging, corrosion, and mechanical damage are additional factors which could lead to electrical failure of the connector.

Using two contacts or a contact and the shell as electrodes, 1500 volts was applied between the electrodes of an unmated connector for one minute as described in MIL-C-26500. Electrical integrity of the connector was achieved provided the connector displayed no evidence of flashover and held the electrical potential with no breakdown, defined as greater than 2.0 milli-amps current leakage.

The results of the dielectric tests are shown in Table 15, along with the maintenance aging results. The dielectric integrity of the connectors remained after maintenance aging. A higher applied potential did not cause failures. Contamination found in the connectors, such as the fine metallic particles, also did not appear to have an effect on dielectric failures.

Table 15: Maintenance Aging Results

<u>Samples</u>	<u>Area</u>	<u>Specimen</u>	<u>Number of Contacts/Cycles</u>	<u>Observations</u>	<u>Results, Dielectric</u>	<u>Results</u>
DC-10	S6	Burndy DC26F22-55 8X	7/10	Sockets could not be removed	Pass 1500 Volts for 1 minute	Fail
DC-10	S6	Glenair DC2SF20- 39S	9/10	Grommet disintegrated in some areas. Wire pulled out of 2 sockets	Pass 1500 Volts for 1 minute	Fail
White 747	S1	Amphenol MS24266R16B24SN	3/10	Removed and installed contacts easily	Pass 1500 Volts for 1 minute	Pass
White 747	S1	Amphenol MS27291-4	4/10	Backshell full of dirt and sticky residue from tape deterioration	Pass 1500 Volts for 1 minute	Pass
White 747	S4	39769B1211Pyle22B -4C-1022-32S	3/10	No comments	Pass 1500 Volts for 1 minute	Pass
White 747	S4	MS24266R12	3/10	Removed and installed contacts easily	Pass 1500 Volts for 1 minute	Pass
European 747	S1	Cinch NULINE MS27291-6	3/10	Removed and installed contacts easily	Pass 1500 Volts for 1 minute	Pass
European 747	S1	Amphenol MS27291-4	3/10	Removed and installed contacts easily. After 5 cycles, 1 cavity could not retain contact.	Pass * 2500 Volts for 6 minutes	Fail

* Note – The dielectric withstanding voltage was run up to 2500 Volts for a full six minutes, instead of the nominal 1500 Volts for one minute, and the connector continued to maintain electrical integrity.

3.6 DISCUSSION SUMMARY

The wire insulation underwent a test program that is designed to evaluate new wires. New wires are expected to provide a certain service life once installed on aircraft, but over time the wire ages and may exhibit decreased performance properties and a lowered threshold for future service life. Wire samples pulled from the subject aircraft appeared to be in similar condition. Although the wire samples were in generally decent condition for having 25 years service life, there were problems evident during the inspection and performance testing. A couple of wire specimens failed dielectric withstanding, and potentially could have lead to electrical shorts in the aircraft given the opportunity for the conductor to ground at that location. Most of the wire passed a dielectric test, indicating that the electrical integrity of the wire remained. Wire damage may have occurred by human or environmental means, such as through manufacturing and assembly, maintenance, vibration, chafing, or many other possibilities.

The three wire samples passed the majority of the performance tests: concentricity, insulation resistance, insulation tensile and elongation, notch sensitivity, and accelerated aging, to the requirements that new wire must pass. All specimens except one passed the wrapback test, and the one failed specimen may have passed without damage that appeared to have been caused by the strippers during the testing.

The wire samples did not pass several other tests. The single layer BMS 13-48 type insulated sample exhibited two dielectric failures in long wire lengths. The dual layer BMS 13-48 wire failed the low temperature cold bend. The M81044/9 wire failed the low temperature cold bend and the lifecycle tests. Both dual wall insulated samples failed the cold bend, which may be due to the greater rigidity of the outer layer of insulation, and possible loss of insulation flexibility during aging while in service on the aircraft. Both of these samples did pass the dielectric withstanding test following the bend. All M81044/9 wire specimens failed the lifecycle test, indicating that the long-term life of this wire type may be limited. The wires have not reached their final life on either wire construction.

The aged wire in this test program continued to perform to many of the requirements demanded of new wire. The failed tests pointed out the weaknesses in the wire after many years of use. With the exception of specific mechanical damage already incurred by the wire samples, the wire of all three aircraft would be expected to retain short-term mechanical and electrical integrity. The long-term performance of the M81044/9 wire is expected to be very poor as the wire continues to degrade from exposure to additional mechanical, thermal, electrical, moisture, radiation, chemical, and human induced stress. The long-term performance of the BMS 13-48 type wire is expected to be somewhat better, although the flexibility of the insulation will decrease further as aging effects become more apparent.

All of the connectors passed the dielectric testing performed, indicating that the contacts continued to be insulated from each other and the shell. The failed connectors of all three aircraft appear to have degraded somewhat from what would be expected of new connectors. The connectors from the DC-10 are in worse physical condition, tend to have fewer supports for the wire, and are covered with greater amounts of dirt, smoke residue, and corrosion. The connector grommets have deformed, and during maintenance aging, the grommets have begun to crumble, jeopardizing its ability to provide environmental sealing. In addition, the contacts of one connector could not be removed, making repair impossible, and the ability of the other connector to retain contacts was lost. The tape support of connectors of the White 747, used to hold the wire, had deteriorated, potentially leading to further damage due to chafing and vibration. A connector from the European 747 lost the ability to retain one contact during maintenance aging. The history of each of these connectors is unknown, and they may have degraded with previous maintenance, but the effects of aging on the connectors would show similarly. The aging effects of these connectors are becoming apparent, and the ability of these connectors to perform is expected to gradually diminish.

4. CONCLUSIONS

Evaluation of three wire types and connectors from three different aircraft.

4.1 General Condition

- The three wire types evaluated from the aircraft were in fairly good condition.
- Areas of damage were found in two of the wire samples.
- Connectors from the three aircraft displayed varied conditions of cleanliness.
- A variety of problems were found during the wire inspection:
 - The presence of a brown film (possibly due to cigarette smoke residue) on connectors and wire from all three aircraft, but much worse on the DC-10
 - Paint and lubricant residue on several connectors of the White 747 and European 747
 - Foreign debris, such as lint and metal filings on wire and connectors
 - Mechanical damage to wire
 - Strain relief damage due to degradation of tape to protect too few wires may possibly lead to wire damage
 - Grommet deformation and hardening in connectors

4.2 Wire Performance Tests

- Many of the performance requirements were passed successfully by the aged wires
- Electrical Tests
 - Damaged wire resulted in dielectric failures
- Mechanical Tests
 - The wire specimens continued to meet the original requirements for tensile and elongation
 - All three wire constructions should continue to resist propagation of minor nicks and cuts without imminent dielectric failures, as seen from the notch sensitivity results.
- Thermal Tests
 - Both dual layer insulated wires failed the low temperature cold bend. The outer crosslinked layer is rigid and was not able to withstand the physical bend while under cold conditions. The inner insulation layer continued to protect from dielectric failure.
 - The wire samples exhibited good resistance to stress under temperature in the wrapback test.
- Thermal Aging Tests
 - All specimens passed accelerated aging test.
 - BMS 13-48 type wire passed the lifecycle test.
 - M81044/9 type wire did not pass the lifecycle test, indicating limited life under increased thermal exposure.

4.3 Connector Performance Tests

- Aging Tests
 - Connectors from each aircraft have been affected by aging.
 - Grommets on the DC-10 connector began crumbling, potentially leading to loss of dielectric, and loss of sealing ability.
 - Contacts in one DC-10 connector could not be removed.
 - Ability for contact retention in several connectors was lost during the maintenance aging test.
 - Connectors have aged to the point where maintenance may become an issue. Connectors must have ability to have contacts inserted and removed, and maintain sealability.
- Electrical Tests

- All connectors passed the dielectric withstanding tests indicating the ability to effectively insulate the contacts from each other and the shell after maintenance aging.

4.3 Overall Conclusions

- The three wire types evaluated have degraded in different manners during service life.
- Single layer BMS 13-48 type wire developed dielectric failures, possibly due to the thinner wall thickness providing less mechanical protection to the wire.
- Dual layer BMS 13-48 type wire passed tests without dielectric failures, but the outer layer has lost strength and flexibility as evidenced by the tensile & elongation and low temperature cold bend tests.
- Dual layer M81044/9 type wire failed a couple tests. The outer layer cracked during the low temperature cold bend test even though retaining electrical integrity. The wire failed lifecycle tests, indicating that the wire has aged significantly and has limited additional life.
- The BMS 13-48 wire appeared to be in better physical shape than the BMS 13-42 wire tested in Reference 1.
- No wire was submitted that was exposed to high levels of environmental exposure. Wire from these areas, wheel wells, leading edges, etc., would be expected to perform worse than the wire submitted.
- The connectors from all three aircraft show signs of aging, such as the presence of corrosion and hardening grommets.
- Connectors from all three aircraft passed dielectric testing indicating the insulate the contacts from each other and the shell, but several of the connectors do not have the ability to have maintenance performed on the connectors. Contacts were not retained, grommets began to crumble, and some contacts were not removable.

APPENDIX I

Boeing BMS 13-48C

Wire Specification

1. SCOPE

This specification covers insulated wire and cable with copper or high strength copper alloy conductors and a primary insulation of Ethylenetetrafluoroethylene (ETFE).

The wire and cable specified herein is intended for "General Purpose" use in both pressurized and unpressurized areas of aircraft. Its application will include exposure to temperatures from -65C to +150C and to various corrosive fluids. The operating potential of circuits where this wire and cable is utilized will be limited to 600 Vrms. Stabilized conductor temperature during continuous operation will be limited to 150C. This specification requires qualified products.

CONTENTS

PARAGRAPH	TITLE	PAGE
1.	SCOPE	1
2.	CLASSIFICATION	2
3.	REFERENCES	5
4.	REQUIREMENTS	6
4.1	COLOR CODE	6
4.2	CONDUCTOR	7
4.3	INSULATION	8
4.4	CONSTRUCTION	9
4.5	PERFORMANCE REQUIREMENTS	35
4.5.1	DESIGN AND PERFORMANCE	38 (46)*
4.5.1.1	ACCELERATED AGING AND LIFE CYCLE	38 (46)
4.5.1.2	BLOCKING	38 (47)
4.5.1.3	COLD BEND	38 (47)
4.5.1.4	CONCENTRICITY	38 (48)
4.5.1.5	CONDUCTOR DC RESISTANCE	38 (48)
4.5.1.6	CONDUCTOR ELOGATION AND TENSILE STRENGTH	38 (48)
4.5.1.7	CURRENT OVERLOAD	39 (48)
4.5.1.8	DEFORMATION	39 (49)
4.5.1.9	DIELECTRIC	39 (52)
4.5.1.10	DYNAMIC CUT-THROUGH	40 (54)
4.5.1.11	FLAMMABILITY	40 (55)
4.5.1.12	FLEXURE ENDURANCE	40 (57)
4.5.1.13	HUMIDITY RESISTANCE	40 (58)
4.5.1.14	IMMERSION	40 (58)
4.5.1.15	INSULATION ELONGATION AND TENSILE STRENGTH	41 (59)
4.5.1.16	INSULATION RESISTANCE	41 (59)
4.5.1.17	INSULATION SHRINKAGE OR ELONGATION	41 (59)
4.5.1.18	NOTCH SENSITIVITY	41 (60)
4.5.1.19	POLYIMIDE CURE	41 (60)
4.5.1.20	SCRAPE ABRASION RESISTANCE	41 (60)
4.5.1.21	SHIELD COVERAGE	41 (61)
4.5.1.22	SMOKE	41 (62)
4.5.1.23	SURFACE RESISTANCE	41 (62)
4.5.1.24	TAPE ABRASION RESISTANCE	42 (63)
4.5.1.25	THERMAL SHOCK RESISTANCE	42 (65)
4.5.1.26	WEIGHT	42 (65)
4.5.1.27	WICKING	42 (65)
4.5.1.28	WIRE TO WIRE ABRASION	42 (65)
4.5.1.29	WRAP TEST	42 (66)
4.5.2	HANDLING, ASSEMBLY, AND INSTALLATION	42 (66)
4.5.2.1	FLEXIBILITY	42 (66)
4.5.2.2	DURABILITY OF PRODUCT IDENTIFICATION	43 (67)
4.5.2.3	MARKABILITY	43 (67)
4.5.2.4	INSULATION REMOVAL	43 (68)
4.5.3	PRODUCT CONTROL	43 (68)
4.5.3.1	JACKET FLAW	43 (68)
4.5.3.2	WORKMANSHIP	43 (70)
4.5.3.3	VISUAL AND DIMENSIONAL	43 (70)
5.	VENDOR QUALIFICATION	44
6.	PURCHASER ACCEPTANCE	45
7.	TEST METHODS	46
8.	IDENTIFICATION	71
9.	PACKAGING AND MARKING	72

* TEST METHOD PAGE NUMBERS

BY <i>J. A. Woodfield</i>	CUSTOMER APPVL.	WIRE, ELECTRIC, EXTRUDED ETHYLENE-TETRAFLUOROETHYLENE (ETFE) 600V (RMS), 150C	BMS 13-48C PAGE 1 OF 77
CK'D <i>L. P. Harris</i>	Q. C. <i>E. Hines</i>	BOEING MATERIAL SPECIFICATION	
ENG <i>Wes Taylor</i>	MAT'L <i>W. L. ...</i>		

2. CLASSIFICATION

2.1 DEFINITIONS

MODULE WIRE AND CABLE

A wire with a light weight insulation wall thickness designed for use in protected areas such as black boxes, and equipment modules.

2.1.2 INTERCONNECT WIRE AND CABLE (NORMAL WEIGHT)

A wire construction with normal weight insulation wall thickness designed for wire and wire bundles use in general applications throughout the aircraft.

2.1.3 HOOK-UP WIRE AND CABLE

A wire with a medium weight insulation wall thickness for application in environments which are more severe than the protected areas but not as severe as the areas where interconnect wire is used.

2.1.4 INTERCONNECT WIRE AND CABLE (HEAVY WEIGHT)

A wire construction with heavy weight insulation wall thickness designed for wire and wire bundles exposed to greater than normal mechanical stresses.

2.1.5 WIRE

Wire is that family of finished items which consist of a single metallic conductor (made up of the number and size of strands as defined in Section 4.2, and constructed as defined in Section 4.4.1) which is covered with the insulation system only, and which does not incorporate any shield or jacket applied over the insulation system, except that certain large gauge wires may be covered with a protective braid as defined in Section 4.4.4.

In this specification, Wires are those items designated as Type I, V, VIII, IX, X, XI, XVI, or XIX, Class 1, all AWG gauges.

2.1.6 CABLE

Cable is that family of finished items which consist of a twisted group of two or more Wires, with or without a shield, or a jacket, or a shield and a jacket covering, and a single Wire which is covered by a shield, or a jacket, or a shield and a jacket, except for those single wires covered by a non-metallic protective braid which are defined as Wires in Section 2.1.4.

In this specification cables are those items designated as Type I, V, VIII, IX, X, XI, XVI, XIX, XXII, or XXIII, Class 2 on, all AWG gauges, and Type III, IV, VI, VII, XII, XIII, XIV, XV, XVII, XVIII, XX, or XXI, all Classes and AWG gauges.

2.1.7 STRAND

A strand is a single length of drawn metal (generally with a round cross section) which is used to construct a conductor as detailed in Section 4.2, or a shield as detailed in Section 4.4.3.2.

In this specification the strand must have a round cross section, and must be of Tin-Coated Soft Annealed Copper per Section 4.2.1.1, or Silver-Plated High-Strength Copper Alloy per Section 4.2.1.2. The type of strand material required for each Type of Wire or Cable conductor is detailed in Section 2.2.

2.2 TYPE

- a. Type I - Module Wire or Cable - 6 mil nominal (5 mil minimum) insulation, tin-coated copper conductor.
One insulated conductor or two or more insulated conductors laid in a suitable spiral to make a multiconductor cable.
- b. Type II - Not Applicable
- c. Type III - Module Shielded and Jacketed Cable - 6 mil nominal (5 mil minimum) insulation, tin-coated copper conductor.
Type I wire or cable over which the following is applied:
First -- An overall shield of tin-coated copper braid. Second -- A jacket of ethylenetetrafluoroethylene (ETFE).
- d. Type IV - Module Jacketed Cable - 6 mil nominal (5 mil minimum) insulation, tin-coated copper conductor.
Type I cable (Class 2 or greater) over which an ETFE jacket is applied.

- e. Type V - Module Wire or Cable - 6 mil nominal (5 mil minimum) insulation, silver-plated high-strength copper alloy conductor.
One insulated conductor or two or more insulated conductors laid in a suitable spiral to make a multiconductor cable.
- f. Type VI - Module Shielded and Jacketed Cable - 6 mil nominal (5 mil minimum) insulation, silver-plated high-strength copper alloy conductor.
Type V wire or cable over which the following is applied:
First -- An overall shield of tin-coated copper braid. Second -- A jacket of ETFE.
- g. Type VII - Module Jacketed Cable - 6 mil nominal (5 mil minimum) insulation, silver-plated high-strength copper alloy conductor.
Type V cable (Class 2 or greater) over which an ETFE jacket is applied.
- h. Type VIII - Interconnect Wire or Cable (Normal Weight) - 10 mil nominal (9 mil minimum) insulation, tin-coated copper conductor.
One insulated conductor or two or more insulated conductors laid in a suitable spiral to make a multiconductor cable.
- i. Type IX - Interconnect Wire or Cable (Normal Weight) - 10 mil nominal (9 mil minimum) insulation, silver-plated high-strength copper alloy conductor.
One insulated conductor or two or more insulated conductors laid in a suitable spiral to make a multiconductor cable.
- j. Type X - Hook-up Wire or Cable - 8 mil nominal (7 mil minimum) insulation, tin-coated copper conductor.
One insulated conductor or two or more insulated conductors laid in a suitable spiral to make a multiconductor cable.
- k. Type XI - Hook-up Wire or Cable - 8 mil nominal (7 mil minimum) insulation, silver-plated high-strength copper alloy conductor.
One insulated conductor or two or more insulated conductors laid in a suitable spiral to make a multiconductor cable.
- l. Type XII - Hook-up Shielded and Jacketed Cable - 8 mil nominal (7 mil minimum) insulation, tin-coated copper conductor.
Type X wire or cable over which the following is applied:
First -- An overall shield of tin-coated copper braid. Second -- A jacket of ETFE.
- m. Type XIII - Hook-up Shielded and Jacketed Cable - 8 mil nominal (7 mil minimum) insulation, silver-plated high-strength copper alloy conductor.
Type XI wire and cable over which the following is applied:
First -- An overall shield of tin-coated copper braid. Second -- A jacket of ETFE.
- n. Type XIV - Hook-up Jacketed Cable, 8 mil nominal (7 mil minimum) insulation, tin-coated copper conductor.
Type X cable (Class 2 or greater) over which an ETFE jacket is applied.
- o. Type XV - Interconnect Shielded and Jacketed Cable (Normal Weight) - 10 mil nominal (9 mil minimum) insulation, tin-coated copper conductor.
Type VIII wire and cable over which the following is applied:
First -- An overall shield of tin-coated copper braid. Second -- A jacket of ETFE.
- p. Type XVI - Interconnect Wire or Cable (Heavy Weight) - 15 mil nominal (14 mil minimum) insulation, tin-coated copper conductor.
One insulated conductor or two or more insulated conductors laid in a suitable spiral to make a multiconductor cable.

- q. Type XVII - Interconnect Jacketed Cable (Heavy Weight) - 15 mil nominal (14 mil minimum) insulation, tin-coated copper conductor.
Type XVI (Class 2 or greater) cable over which an ETFE jacket is applied.
- r. Type XVIII - Interconnect Shielded and Jacketed Cable (Heavy Weight) - 15 mil nominal (14 mil minimum) insulation, tin-coated copper conductor.
Type XVI wire or cable over which the following is applied:
First -- An overall shield of tin-coated copper braid. Second -- A jacket of ETFE.
- s. Type XIX - Interconnect Wire or Cable (Heavy Weight) - 15 mil nominal (14 mil minimum) insulation, silver-plated high-strength copper alloy conductor.
One insulated conductor or two or more insulated conductors laid in a suitable spiral to make a multiconductor cable.
- t. Type XX - Interconnect Jacketed Cable (Heavy Weight) - 15 mil nominal (14 mil minimum) insulation, silver-plated high-strength copper alloy conductor.
Type XIX (Class 2 or greater) cable over which an ETFE jacket is applied.
- u. Type XXI - Interconnect Shielded and Jacketed Cable (Heavy Weight) - 15 mil nominal (14 mil minimum) insulation, silver-plated high-strength copper alloy conductor.
Type XIX wire or cable over which the following is applied.
First -- An overall shield of tin-coated copper braid. Second -- A jacket of ETFE.
- v. Type XXII - Interconnect Wire or Cable (Heavy Weight) - 15 mil nominal (14 mil minimum) insulation, nickel-coated high-strength copper alloy conductor. R
One insulated conductor or two or more insulated conductors laid in a suitable spiral to make a multiconductor cable.
- w. Type XXIII - Interconnect Wire or Cable (Normal Weight) - 10 mil nominal (9mil minimum) insulation, nickel-coated high-strength copper alloy conductor. R
One insulated conductor or two or more insulated conductors laid in a suitable spiral to make a multiconductor cable.
- x. Type XXIV - Interconnect Shielded and Jacketed Cable (Normal Weight) - 10 mil nominal (9 mil minimum) insulation, nickel-coated high-strength alloy conductor. R
Type XXIII wire or cable over which the following is applied:
First -- An overall shield of tin-coated copper braid.
Second -- A jacket of ETFE.

2.3 CLASS

- a. The class designation for all wires and cables of this specification shall be specified by numbers, in numerical order, which shall indicate a single insulated wire or the number of insulated wires in a multi-conductor cable.
- b. Examples: Class 1 - A single insulated conductor
Class 2 - Two spirally laid wires (twisted-pair)
Class 24 - 24 spirally laid wires

2.4 SIZE

This specification covers wire sizes 26 AWG through 4/0 AWG. The construction details for the various sizes shall be controlled by Section 4. of this specification.

2.5 WIRE AND CABLE DESIGNATION

Designation of the wire and cable controlled by this specification shall be in the following form:

<u>BMS 13-48C/XX</u>	<u>TYPE</u>	<u>CLASS</u>	<u>SIZE</u>
Boeing Material Specification Number/Mfg. QPL- Qualified Supplier Sheet Number	Wire or Cable Type Designation (See Section 2.2)	Wire or Cable Class Designation (See Section 2.3)	Individual Wire Size (See Section 2.4)

3. REFERENCES

Except where a specific issue is indicated, the latest issue of the following references shall be considered a part of this specification to the extent indicated herein.

3.1 SPECIFICATION

3.1.1 FEDERAL

- a. C-F-206, Felt Sheet: Cloth, Felt, Wool, Pressed
- b. TT-I-735, Isopropyl Alcohol, Technical
- c. UU-T-450, Tissue, Facial
- d. TT-M-261, Methyl-Ethyl-Ketone
- e. FAR, Part 25

3.1.2 MILITARY

- a. MIL-H-5606, Hydraulic Fluid, Petroleum Base, Aircraft and Ordnance
- b. MIL-T-5624, Turbine Fuel, Aviation Grades JP-4 and JP-5
- c. MIL-L-7808, Lubricating Oil, Aircraft Turbine Engine, Synthetic Base
- d. MIL-L-23699, Lubricating Oil, Aircraft Turbine Engine, Synthetic Base
- e. MIL-T-5438, Tester, Abrasion, Electrical Cable
- f. MIL-E-9500, Ethylene Glycol, Technical
- g. MIL-P-83800, Propylene Glycol, Industrial Grade
- h. MIL-C-572, Cords, Yarns and Monofilaments Organic and Synthetic Fiber

3.2 STANDARDS

3.2.1 FEDERAL

FED-STD-228, Cable and Wire, Insulated; Method of Testing

3.2.2 MILITARY

- a. MIL-STD-104, Limits for Electrical Insulation Color
- b. MIL-STD-105, Sampling Procedures and Tables for Inspection Attributes

3.3 OTHER PUBLICATIONS

3.3.1 COMMERCIAL

Munsell Book of Color, Munsell Color Company, Baltimore, Maryland

3.3.2 BOEING

BMS 3-11, Hydraulic Fluid, Fire Resistant

3.4 AMERICAN SOCIETY FOR TESTING AND MATERIALS (ASTM)

- a. ASTM B3, Soft or Annealed Copper Wire, Spec. for
- b. ASTM B33, Standard Specification for Tinned Soft or Annealed Copper Wire for Electrical Purposes
- c. ASTM B298, Specification for Silver-Coated Soft or Annealed Copper Wire
- d. ASTM B355, Standard Specification for Nickel-Coated Soft or Annealed Copper Wire.
- e. ASTM D1371, Recommended Practice for Cleaning Plastic Specimens for Insulation Resistance, Surface Resistance and Volume Resistivity Testing
- f. ASTM E104, Recommended Practice for Maintaining Constant Relative Humidity by Means of Aqueous Solutions.

4. REQUIREMENTS

a. This specification is intended to define only those requirements which are essential to control the physical, mechanical, and electrical characteristics to the degree necessary to ensure:

- (1) Compatibility with stripping, marking and other sub-assembly and installation tooling.
- (2) Minimum weight
- (3) Ease of handling in sub-assembly
- (4) Ease of handling in installation
- (5) Long term life, performance, and reliability
- (6) Installation compatibility

Therefore, this specification allows variations in material formulation and construction within the general framework of the scope of this specification.

b. The wire and cable furnished under this specification shall be a product which has been tested, and has passed the qualification tests specified herein, prior to acceptance of production orders.

NOTE: WIRE AND CABLE FABRICATED TO MEET THE REQUIREMENTS OF THE ORIGINAL ISSUE OF BMS 13-48 DOES NOT MEET THE REQUIREMENTS OF THIS SPECIFICATION.

c. Where conflict exists between this specification and any specification referenced herein, this specification shall govern.

4.1 COLOR CODE

Except as specified in Section 4.4, or otherwise specified in the purchase order, the color of the finished wire or cable shall be as follows.

4.1.1 ALL TYPES AND SIZES, CLASS 1

Other than Type VIII, Class 1, AWG 22, the finished wire and cable shall be white within the limits of MIL-STD-104, Class 1. Type VIII, Class 1, AWG 22 wire shall be pastel green between the Munsell Renotation of 2.5G 8/4 to 10G 9/2.

In the event that a red wire is specified, the red shall be between Munsell Renotation 2.5R 4/10 and 5R 6/14.

4.1.2 ALL TYPES AND SIZES, CLASS 2 THROUGH 24

The finished color for wires in the multiconductor cable shall be as shown in Table I. On the 11th through the 24th wire a stripe of the color shown in Table I shall be applied to the outer surface of the insulation. The stripe shall be not less than .030 inch wide and shall make one complete turn around the wire in every two inches of axial length for wire sizes 26 through 12, and in every four inches of axial length for wire sizes 10 through 4/0. The jacket of shielded or multiconductor cables shall be white per MIL-STD-104.

4.1.2 (Continued)

TABLE I
COLOR CODE FOR WIRES IN MULTICONDUCTOR CABLE

WIRE NUMBER	INSULATION COLOR	STRIPE COLOR
1	Red	----
2	Blue	----
3	Yellow	----
4	Green	----
5	Black	----
6	Purple	----
7	Orange	----
8	Brown	----
9	Pink	----
10	White	----
11	White	Red
12	White	Blue
13	White	Yellow
14	White	Green
15	White	Black
16	White	Purple
17	White	Orange
18	White	Brown
19	White	Pink
20	Red	Blue
21	Red	Yellow
22	Red	Green
23	Red	Black
24	Red	Purple

NOTE: Pink shall be between Munsell Renotation 2.5R - 10R 9/2, or SRP - 10RP 8/6, with the lighter value preferred.

4.2 CONDUCTOR

4.2.1 CONDUCTOR MATERIAL

All strands used in the manufacture of the conductors shall be soft annealed copper conforming to ASTM B3, or shall be high-strength copper alloy. Strands shall be free from lumps, kinks, splits, scrapes, corroded surfaces and skin impurities. Strands shall not fuse together. In addition, the strands shall conform to the following requirements as applicable.

4.2.1.1 Tin-Coated Soft Annealed Copper Strands

The strands shall be of the applicable AWG specified in Table II and of such tensile strength and elongation properties that the conductor from the finished wire conforms to the requirements of Section 4.5.1.6. The tin coating shall be as specified in ASTM B33.

4.2.1.3 Nickel-Coated High-Strength Copper Alloy

The strands shall be of the applicable AWG specified in Table II. They shall conform to the requirements of Section 4.5.1.6 for elongation and tensile strength, and shall be nickel-coated in accordance with ASTM B355 with not less than 50 microinches of nickel.

4.2.1.2 Silver-Plated High-Strength Copper Alloy

The strands shall be of the applicable AWG specified in Table II. They shall conform to the requirements of Section 4.5.1.6 for elongation and tensile strength, and shall be silver-plated in accordance with ASTM B298 with not less than 40 microinches of silver.

TABLE II
DETAIL OF CONDUCTORS

WIRE SIZE AWG	CONDUCTOR STRANDS			STRANDED CONDUCTOR					
	NO.	AWG	NOMINAL DIAMETER (INCHES)	DIAMETER OF STRANDED CONDUCTOR (INCHES)		NOMINAL AREA CIRCULAR (MILS)	MAXIMUM DC RESISTANCE (OHMS/M FT. AT 20C MAX.)		
				MIN.	MAX.		TIN-COATED COPPER	SILVER-PLATED COPPER-ALLOY	NICKEL-COATED COPPER-ALLOY
26	19	38	0.0040	0.018	0.021	304	41.3	44.8	49.4
24	19	36	0.0050	0.023	0.026	475	26.2	28.4	30.1
22	19	34	0.0063	0.029	0.033	754	16.2	17.5	18.6
20	19	32	0.0080	0.037	0.041	1,216	9.88	10.9	11.4
18	19	30	0.0100	0.046	0.051	1,900	6.23	6.8	7.1
16	19	29	0.0113	0.052	0.058	2,426	4.82	5.3	5.5
14	19	27	0.0142	0.065	0.073	3,831	3.06		
12	37	28	0.0126	0.084	0.090	5,874	2.02		
10	37	26	0.0159	0.106	0.114	9,354	1.26		
8	133	29	0.0113	0.158	0.173	16,983	0.701		
6	133	27	0.0142	0.198	0.217	26,818	0.445		
4	133	25	0.0179	0.250	0.274	42,615	0.280		
2	665	30	0.0100	0.320	0.340	66,500	0.183		
1/0	1045	30	0.0100	0.405	0.425	104,500	0.116		
2/0	1330	30	0.0100	0.450	0.475	133,000	0.091		
3/0	1665	30	0.0100	0.515	0.540	166,500	0.071		
4/0	2109	30	0.0100	0.580	0.605	210,900	0.056		

4.3 INSULATION

The primary insulation shall be virgin ethylenetetrafluoroethylene (ETFE) resin applied tightly on the conductor, but with no adherence. The resin shall be 100 percent new material containing no additives except pigmentation for color, stabilizers, fillers, extrusion lubricants or compatible materials to improve basic characteristics.

Virgin material shall be 100 percent new material which has been through only the processes essential to its manufacture and its application to the wire and has been through these essential processes one time only. Any material which has previously been processed in any other manner is considered non-virgin material. This requirement shall apply to the manufacture of all ingredients and components used. Thickness of the insulation is defined in Section 2.2.

4.3 (Continued)

The primary insulation may be covered with a jacket or coating. However, any such jacket or coating shall not be used as a substitute for, or in place of, the primary insulation. Such jacket or coating must enhance the overall performance of the wire assembly and shall in no way degrade the performance of the wire assembly below that which would exist without a jacket or coating. Any such jacket or coating which may be applied over the primary ETFE insulation must conform to the color requirements specified in Section 4.1. Said jacket or coating must meet all requirements of this specification. Coating thickness shall be within 0.001 ± 0.0005 inch. Jacket thickness is defined in Section 4.4.3.3.

4.4 CONSTRUCTION

4.4.1 CONDUCTOR

4.4.1.1 Conductor Stranding

- a. The conductors of wire sizes 26 through 10 shall be as specified in Table II and shall be concentric lay conductors. Concentric lay shall be interpreted to be a central strand surrounded by one or more layers of helically wound strands. It is optional for the direction of lay of the successive layers to be alternately reversed (true concentric lay) or to be in the same direction (unidirectional lay). The strands shall be assembled in a geometric arrangement of concentric layers so as to produce a smooth and uniform conductor, circular in cross-section, and free of any crossovers, high strands, or other irregularities. The direction of lay of the individual strands in the outer layer of the concentrically stranded conductors of finished wire shall be left-hand. The length of the lay of the outer layer shall not be less than 8 or more than 16 times the maximum conductor diameter as specified in Table II.
- b. The conductors of wire sizes 8 through 4/0 shall be as specified in Table II, shall be rope lay, and as specified in (1) and (2) below.
- (1) Rope-lay stranded conductors shall be laid up concentrically with a central member surrounded by one or more layers of helically wound members. It is optional for the direction of successive layers to be alternately reversed (true concentric lay), or to be in the same direction (unidirectional lay). The length of lay of the outer layer of rope-lay stranded members forming the conductor shall not be less than 10 or more than 14 times the outside diameter of the completed conductor. The direction of lay of the outside layer shall be left-hand.
- (2) Members of rope-lay stranded conductors: The length of lay of the wires composing the stranded members shall not be greater than 16 times the outside diameter of the member. Stranding of the individual members may be either concentric or bunch.

4.4.1.2 Conductor Splices

Splices in individual strands or members shall be butt brazed. There shall not be more than one strand-splice in any two lay lengths of a stranded concentric-lay conductor, or in any two lay lengths of any member in a rope lay conductor, except that not more than one splice of an entire member shall be permitted in any two lay lengths of a rope lay conductor. Splices in members of a rope lay construction shall be so finished that the conductor diameter is not increased at the point of brazing. In no case shall the whole conductor be spliced at one point.

4.4.2 FINISHED WIRE

The finished wire diameter shall meet the requirements of Section 4.4. Also, the surface of the insulation shall provide a finish which will retain a mark imprinted by hot stamping, and deposited by ink jet without a pre-etch by the user. When the insulation is multilayered, the color of each layer (excluding any wash-coat) shall be such as to make it visually discernible from all other layers. The insulation shall be constructed so that it can be readily removed by, but not limited to, the wire-stripping devices listed below. The conductor shall not splay when insulation is removed.

WIRE-STRIPPING DEVICES

1. Simplex, Model S-30-C
2. Carpenter, Single Blade Rotary Stripper
3. Ideal Power Stripmaster, Cat. No. 45-145
4. Stripall Thermal Hot Wire Stripper
5. Ideal Handstripper, Model ST2222-26, -27, and -28
6. Boeing Insulation Stripper-Thermal ST2313, MRO 856491-0100

4.4.3 FINISHED CABLE

The construction of finished cable shall be as specified in the individual Type and Class construction details. Class 2 or greater shall not untwist more than one inch when cut as one unit.

4.4.3.1 Cabling Lay

The required number of insulated wires, determined by the class designation, shall be spirally laid in a manner that will result in a concentric cable. The lay of the individual wires shall not be less than 8 or more than 16 times the major diameter of the cable. The direction of the lay shall be left-hand. Fillers shall not be allowed.

4.4.3.2 Shield

Shield strands shall be in accordance with the requirements for conductor materials defined in Sections 4.2.1 and 4.2.1.1. The shield shall be a closely woven braid and shall comply with the following:

- a. The shield strand shall be AWG 38.
- b. The shield shall provide a minimum coverage of 85 percent with coverage being determined in accordance with Section 7.1.23.
- c. The shield shall be a push-back type and shall open up so that a terminating sleeve can slide under it.
- d. The angle of the carriers of the shield with the axis of the cable shall be not less than 20 or more than 35 degrees.

4.4.3.3 Cable Jacket

Cable jackets shall be ETFE and shall be concentrically applied. Minimum jacket wall thickness shall be 0.006 inch when the cable beneath the jacket has an O.D. of 0.215 inch or less, and shall be 0.007 inch when the cable beneath the jacket has an O.D. of more than 0.215 inch. When tested in accordance with Section 7.1.17, jacket material shall have a tensile strength of 5000 psi (minimum), and an elongation of 50 percent (minimum). Unless otherwise specified on the purchase order, the color of the jacket shall be white within the limits of MIL-STD-104. The surface of the jacket shall provide a finish which will retain a mark deposited by an ink jet marking machine per Section 7.2.3.

4.4.4 PROTECTIVE BRAID

If a protective braid is used it shall be restricted to wire sizes AWG 4 and larger and shall be applied over the insulation. The braid material shall conform to MIL-C-572, Type P. It shall be woven in such a manner as to provide complete coverage and shall be impregnated with a clear high temperature lacquer. Thickness shall be .004 inch (minimum). Braid color shall be light green between the Munsell Renotation of 5GY 7/4 to 2.5 BG 6/10.

4.4.5 FINISHED WIRE AND CABLE PHYSICAL DIMENSIONS

The illustrations of Figures 1 through 15 are a few examples of typical insulation configurations which are considered acceptable for aerospace application. These examples are only suggestions and do not exclude the acceptance of other insulation configurations which meet or exceed the requirements of this specification.



SINGLE EXTRUSION

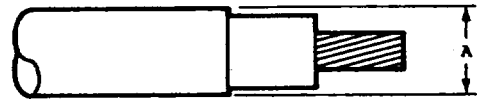

COATED, SINGLE EXTRUSION

CLASS	CONDUCTOR SIZE (AWG)	A INCH MAX.	MAXIMUM WEIGHT (LBS/1000 FT.)
1	24	0.039	2.0
	22	0.045	2.9
	20	0.054	4.4
	18	0.064	6.7
	16	0.072	8.6
	14	0.090	13.2
	12	0.108	20.0
2	24	0.079 ¹	4.0
	22	0.091 ¹	5.8
	20	0.108	8.9
	18	0.128	13.5
	16	0.144	17.8
	14	0.180	27.3
	12	0.216	41.7
3	24	0.085 ¹	6.1
	22	0.098	8.8
	20	0.117	13.3
	18	0.138	20.4
	16	0.156	26.4
	14	0.194	40.7
	12	0.233	62.0
4	24	0.108 ¹	8.1
	22	0.124	11.9
	20	0.149	18.3
	18	0.176	27.2
	16	0.198	35.3
	14	0.248	54.4
	12	0.297	82.9
5	24	0.117 ¹	10.1
	22	0.135	14.9
	20	0.162	22.9
	18	0.192	34.0
	16	0.216	44.2
	14	0.270	68.1
	12	0.328	101.0

¹ Cable maximum outside diameter.

TYPE I WIRE AND CABLE

Figure 1

THIS PAGE IS INTENTIONALLY LEFT BLANK

Figure 2

BMS 13-48C R

PAGE 12

4.4.5

(Continued)

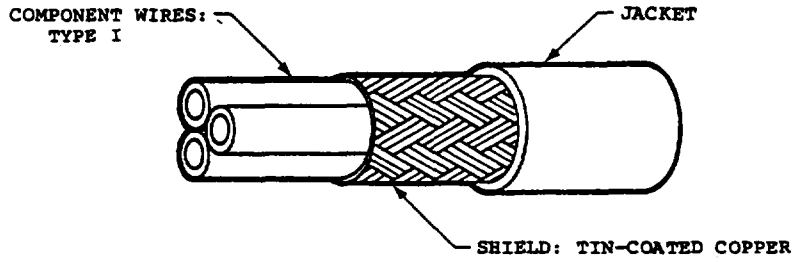

(TYPICAL FOR ALL CLASSES)

CLASS	CONDUCTOR SIZE (AWG)	MAXIMUM OUTSIDE DIAMETER (INCH)	MAXIMUM WEIGHT (LBS/1000 FT)
1	24	0.075	5.6
	22	0.081	6.9
	20	0.089	9.0
	18	0.099	12.0
	16	0.108	14.6
	14	0.125	21.1
2	12	0.143	28.5
	24	0.113	9.4
	22	0.125	12.0
	20	0.141	16.0
	18	0.162	21.9
	16	0.178	26.7
3	14	0.213	38.3
	12	0.251	54.5
	24	0.119	12.3
	22	0.132	15.9
	20	0.149	21.7
	18	0.172	30.4
4	16	0.189	37.4
	14	0.229	54.0
	12	0.270	77.5
	24	0.132	15.4
	22	0.147	20.0
	20	0.168	27.6
4	18	0.193	38.9
	16	0.214	48.2
	14	0.258	69.7
	12	0.305	101.0

TYPE III CABLE

Figure 3

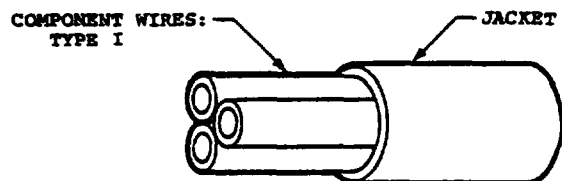

(TYPICAL FOR ALL CLASSES)

CLASS	CONDUCTOR SIZE (AWG)	MAXIMUM OUTSIDE DIAMETER (INCH)	MAXIMUM WEIGHT (LBS/1000 FT)
2	24	0.094	6.0
	22	0.107	8.0
	20	0.123	11.4
	18	0.143	16.2
	16	0.160	20.6
	14	0.194	30.7
3	12	0.233	45.9
	24	0.100	8.1
	22	0.114	11.0
	20	0.131	16.1
	18	0.153	23.4
	16	0.171	29.7
4	14	0.209	44.6
	12	0.250	67.1
	24	0.114	10.5
	22	0.129	14.2
	20	0.149	20.8
	18	0.175	30.9
5	16	0.195	39.2
	14	0.240	59.0
	12	0.287	88.3
	24	0.132	12.8
	22	0.150	17.5
	20	0.175	25.6
5	18	0.205	38.3
	16	0.232	48.6
	14	0.285	73.1
	12	0.348	109.4

TYPE IV CABLE

Figure 4



SINGLE EXTRUSION



COATED, SINGLE EXTRUSION

CLASS	CONDUCTOR SIZE (AWG)	A INCH MAX.	MAXIMUM WEIGHT (LBS/1000 FT)
1	26	0.034	1.4
	24	0.039	2.0
2	26	0.069 1	2.8
	24	0.079 1	4.0
3	26	0.074 1	4.2
	24	0.085 1	6.1
4	26	0.094 1	5.7
	24	0.108 1	8.1

1 Cable maximum outside diameter.

TYPE V WIRE AND CABLE

Figure 5

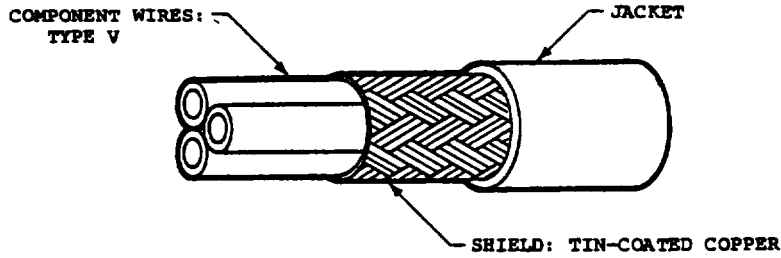

(TYPICAL FOR ALL CLASSES)

CLASS	CONDUCTOR SIZE (AWG)	MAXIMUM OUTSIDE DIAMETER (INCH)	MAXIMUM WEIGHT (LBS/1000 FT)
1	26	0.070	4.6
	24	0.075	5.6
2	26	0.102	7.6
	24	0.113	9.4
3	26	0.108	9.7
	24	0.119	12.3
4	26	0.119	12.0
	24	0.132	15.4

TYPE VI CABLE

Figure 6

4.4.5

(Continued)

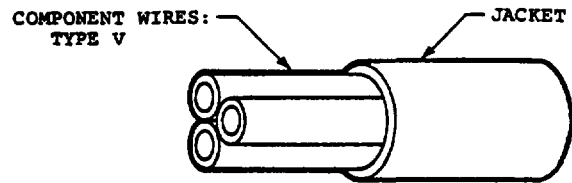

(TYPICAL FOR ALL CLASSES)

CLASS	CONDUCTOR SIZE (AWG)	MAXIMUM OUTSIDE DIAMETER (INCH)	MAXIMUM WEIGHT (LBS/1000 FT)
2	26	0.084	4.1
	24	0.094	6.0
3	26	0.089	5.7
	24	0.100	8.1
4	26	0.100	7.5
	24	0.114	10.5

TYPE VII CABLE

Figure 7



SINGLE EXTRUSION



COATED, SINGLE EXTRUSION

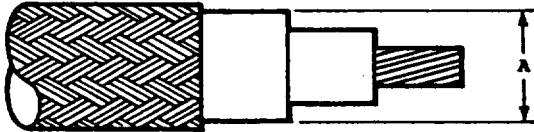

BRAIDED JACKET, DUAL EXTRUSION

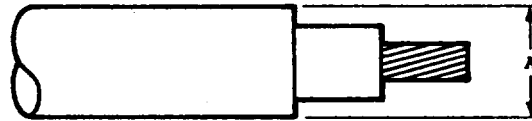

DUAL EXTRUSION

CLASS	CONDUCTOR SIZE (AWG)	A INCH MAX.	MAXIMUM WEIGHT (LBS/1000 FT)
1	24	0.048	2.4
	22	0.054	3.4
	20	0.065	5.0
	18	0.073	7.4
	16	0.082	9.3
	14	0.099	14.2
	12	0.116	21.5
	10	0.142	33.0
	8	0.203	60.9
	6	0.251	94.8
	4	0.320	150.0
	2	0.417	239.0
	1/0	0.516	377.0
	2/0	0.571	487.0
	3/0	0.643	573.0
	4/0	0.708	694.0

TYPE VIII WIRE AND CABLE

Figure 8

4.4.5

(Continued)

CLASS	CONDUCTOR SIZE (AWG)	A INCH MAX.	MAXIMUM WEIGHT (LBS/1000 FT)
2	26	0.086 1	3.6
	24	0.096	4.8
	22	0.110	6.9
	20	0.126	10.0
	18	0.146	16.0
	16	0.164	19.0
	14	0.198	29.0
	12	0.232	44.0
3	26	0.093 1	5.3
	24	0.103	7.3
	22	0.118	10.4
	20	0.135	15.2
	18	0.158	22.5
	16	0.177	28.5
	14	0.214	43.5
	12	0.251	64.5
4	26	0.116 1	7.2
	24	0.129	9.7
	22	0.149	14.0
	20	0.171	20.0
	18	0.201	30.5
	16	0.226	38.2
	14	0.272	59.0
	12	0.319	89.5
5	26	0.126 1	9.0
	24	0.141	12.2
	22	0.162	17.2
	20	0.186	26.0
	18	0.219	38.2
	16	0.246	48.0
	14	0.297	73.8
	12	0.348	111.8
6	26	0.129 1	10.8
	24	0.144	14.7
	22	0.162	20.8
	20	0.195	30.6
	18	0.219	45.3
	16	0.246	56.9
	14	0.297	86.9
	12	0.348	131.6
7	26	0.129 1	12.6
	24	0.144	17.2
	22	0.162	24.3
	20	0.195	35.7
	18	0.219	52.9
	16	0.246	66.4
	14	0.297	101.4
	12	0.348	153.5
8	26	0.168 1	14.4
	24	0.188	19.6
	22	0.216	27.8
	20	0.248	40.8
	18	0.292	60.4
	16	0.328	75.9
	14	0.396	115.9
	12	0.464	175.5

1 Cable maximum outside diameter.

TYPE VIII WIRE AND CABLE

Figure 8

(Continued)

4.4.5 (Continued)



SINGLE EXTRUSION



COATED, SINGLE EXTRUSION

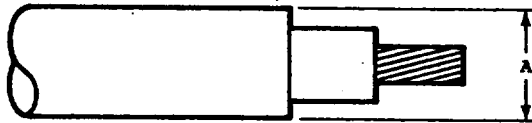

DUAL EXTRUSION

CLASS	CONDUCTOR SIZE (AWG)	A INCH MAX.	MAXIMUM WEIGHT (LBS/1000 FT)
1	26	.043	1.8
	24	.048	2.4
2	26	.086 1	3.6
	24	.096 1	4.8
3	26	.093 1	5.3
	24	.103 1	7.3
4	26	.116 1	7.2
	24	.129 1	9.7
5	26	.126 1	9.0
	24	.141 1	12.2

1 CABLE MAXIMUM OUTSIDE DIAMETER.

TYPE IX WIRE AND CABLE

FIGURE 9

4.4.5

(Continued)



SINGLE EXTRUSION



COATED, SINGLE EXTRUSION



DUAL EXTRUSION

CLASS	CONDUCTOR SIZE (AWG)	A INCH MAX.	MAXIMUM WEIGHT (LBS/1000 FT)
1	24	.043	2.2
	22	.050	3.1
	20	.058	4.7
	18	.069	7.1
	16	.076	9.0
	14	.094	13.8
	12	.112	20.7
	10	.140	32.7
2	24	.086 ¹	4.4
	22	.100	6.2
	20	.116	9.5
	18	.138	14.3
	16	.152	18.1
	14	.188	27.8
	12	.225	41.8

¹ Cable maximum outside diameter

TYPE X WIRE AND CABLE

Figure 10

CLASS	CONDUCTOR SIZE (AWG)	A INCH MAX.	MAXIMUM WEIGHT (LBS/1000 FT)
3	24	.093 ¹	6.7
	22	.108	9.4
	20	.127	14.2
	18	.149	21.5
	16	.164	27.3
	14	.203	41.8
	12	.242	62.7
4	24	.118 ¹	8.9
	22	.138	12.5
	20	.160	19.0
	18	.190	28.7
	16	.209	36.4
	14	.259	55.9
	12	.308	83.8
5	24	.129 ¹	11.2
	22	.150	15.5
	20	.174	23.8
	18	.207	36.0
	16	.228	45.6
	14	.282	70.0
	12	.336	105.0

¹ Cable maximum outside diameter.

TYPE X WIRE AND CABLE

Figure 10 (Continued)

4.4.5

(Continued)



SINGLE EXTRUSION



COATED, SINGLE EXTRUSION



DUAL EXTRUSION

CLASS	CONDUCTOR SIZE (AWG)	A INCH MAX.	MAXIMUM WEIGHT (LBS/1000 FT)
1	26	.037	1.6
	24	.043	2.2
	22	.050	3.1
	20	.058	4.7
	18	.069	7.1
2	26	.074	3.2
	24	.086	4.4
	22	.100	6.3
	20	.116	9.5
	18	.138	14.3
3	26	.080	4.9
	24	.093	6.7
	22	.108	9.4
	20	.125	14.2
	18	.149	21.5
4	26	.102	6.5
	24	.118	8.9
	22	.138	12.6
	20	.160	19.0
	18	.190	28.7
5	26	.111	8.1
	24	.129	11.2
	22	.150	15.7
	20	.174	23.8
	18	.207	36.0

TYPE XI WIRE AND CABLE

Figure 11

4.4.5 (Continued)

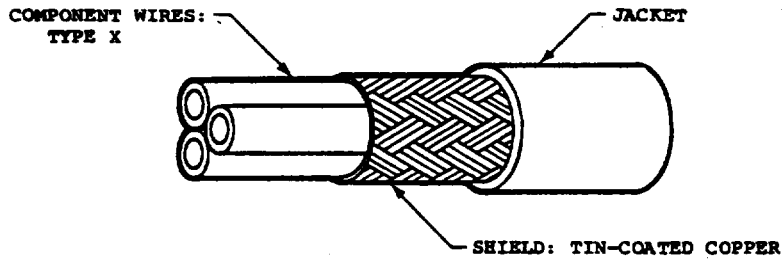

(TYPICAL FOR ALL CLASSES)

CLASS	CONDUCTOR SIZE (AWG)	MAXIMUM OUTSIDE DIAMETER (INCH)	MAXIMUM WEIGHT (LBS/1000 FT)
1	24	.079	6.0
	22	.085	7.4
	20	.093	9.5
	18	.104	12.7
	16	.112	15.3
	14	.129	21.7
	12	.147	29.7
2	24	.121	10.3
	22	.133	12.9
	20	.149	17.2
	18	.172	23.3
	16	.186	27.9
	14	.221	39.9
	12	.261	55.9
3	24	.128	13.4
	22	.141	17.2
	20	.159	23.2
	18	.183	32.4
	16	.198	39.1
	14	.238	57.2
	12	.278	79.9
4	24	.142	17.0
	22	.158	22.4
	20	.178	30.2
	18	.205	42.2
	16	.226	51.1
	14	.270	73.3
	12	.320	104.5

TYPE XII CABLE

Figure 12

4.4.5

(Continued)

COMPONENT WIRES:
TYPE XI

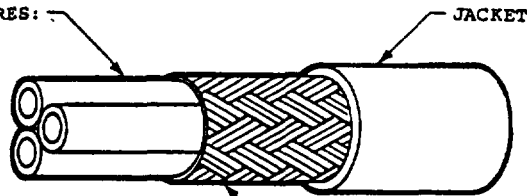

SHIELD: TIN-COATED COPPER

(TYPICAL FOR ALL CLASSES)

CLASS	CONDUCTOR SIZE (AWG)	MAXIMUM OUTSIDE DIAMETER (INCH)	MAXIMUM WEIGHT (LBS/1000 FT)
1	26	.073	5.0
	24	.079	6.0
	22	.085	7.4
	20	.093	9.5
	18	.104	12.7
2	26	.109	8.3
	24	.121	10.3
	22	.133	12.9
	20	.149	17.2
	18	.172	23.3
3	26	.115	11.5
	24	.128	13.4
	22	.141	17.2
	20	.159	23.2
	18	.183	32.4
4	26	.124	13.3
	24	.139	16.7
	22	.154	22.4
	20	.174	30.2
	18	.201	42.2

TYPE XIII CABLE

Figure 13

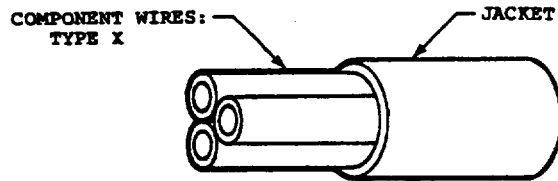

(TYPICAL FOR ALL CLASSES)

CLASS	CONDUCTOR SIZE (AWG)	MAXIMUM OUTSIDE DIAMETER (INCH)	MAXIMUM WEIGHT (LBS/1000 FT)
2	24	0.102	6.1
	22	0.115	8.3
	20	0.131	11.8
	18	0.153	17.0
	16	0.168	21.1
	14	0.202	31.6
	12	0.241	46.2
3	24	0.110	8.6
	22	0.123	11.8
	20	0.140	16.9
	18	0.165	25.1
	16	0.180	31.1
	14	0.219	46.8
	12	0.258	68.6
4	24	0.121	11.3
	22	0.136	15.4
	20	0.155	22.3
	18	0.183	33.0
	16	0.200	41.2
	14	0.244	62.1
	12	0.287	91.2
5	24	0.144	14.0
	22	0.165	19.1
	20	0.189	27.7
	18	0.222	41.1
	16	0.243	51.2
	14	0.299	77.4
	12	0.353	114.0

TYPE XIV CABLE

Figure 14

4.4.5

(Continued)

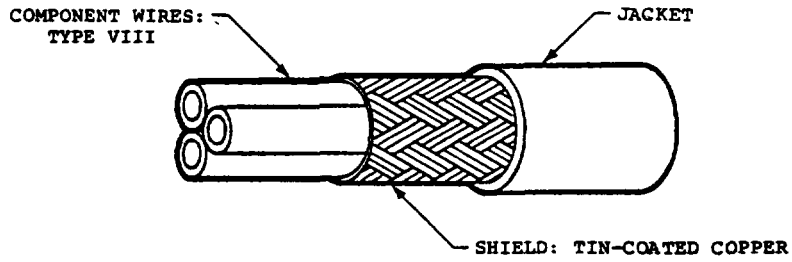

(TYPICAL FOR ALL CLASSES)

CLASS	CONDUCTOR SIZE (AWG)	MAXIMUM OUTSIDE DIAMETER (INCH)	MAXIMUM WEIGHT (LBS/1000 FT)
1	24	.086	6.5
	22	.092	8.4
	20	.103	10.3
	18	.111	13.7
	16	.120	16.0
	14	.137	22.2
	12	.154	30.4
2	24	.134	11.4
	22	.146	14.1
	20	.168	18.7
	18	.184	24.5
	16	.202	29.3
	14	.238	41.7
	12	.272	58.6
3	24	.141	15.1
	22	.154	18.8
	20	.174	25.6
	18	.195	33.9
	16	.214	40.6
	14	.253	58.7
	12	.289	83.9
4	24	.154	18.7
	22	.168	23.3
	20	.195	31.6
	18	.215	42.5
	16	.236	51.9
	14	.279	75.8
	12	.321	107.9

TYPE XV CABLE

Figure 15



SINGLE EXTRUSION



COATED, SINGLE EXTRUSION



DUAL EXTRUSION

CLASS	CONDUCTOR SIZE (AWG)	A INCH MAX.	MAXIMUM WEIGHT (LBS/1000 FT)
1	20	.073	5.9
	18	.084	8.6
	16	.091	10.5
	14	.107	15.3
	12	.126	23.0
	10	.154	35.0

TYPE XVI WIRE AND CABLE

Figure 16

4.4.5 (Continued)

CLASS	CONDUCTOR SIZE (AWG)	A INCH MAX.	MAXIMUM WEIGHT (LBS/1000 FT)
2	20	.146 1	11.9
	18	.168	17.3
	16	.182	21.2
	14	.214	30.8
	12	.252	46.0
3	20	.158 1	17.9
	18	.181	26.1
	16	.197	31.8
	14	.231	46.4
	12	.272	69.0
4	20	.201 1	23.9
	18	.231	34.8
	16	.250	42.5
	14	.294	61.9
	12	.347	92.0
5	20	.219 1	29.9
	18	.252	43.6
	16	.273	53.2
	14	.321	77.6
	12	.378	115.0
6	20	.219 1	36.0
	18	.252	52.4
	16	.273	64.0
	14	.321	93.3
	12	.378	138.0
7	20	.219 1	41.9
	18	.252	61.0
	16	.273	74.5
	14	.321	109.0
	12	.378	161.0
8	20	.292 1	48.0
	18	.336	69.9
	16	.364	85.3
	14	.428	124.0
	12	.504	184.0

1 Cable maximum outside diameter.

TYPE XVI WIRE AND CABLE

Figure 16 (Continued)

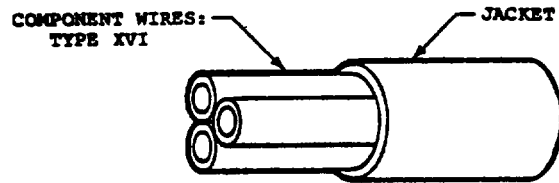

(TYPICAL FOR ALL CLASSES)

CLASS	CONDUCTOR SIZE (AWG)	MAXIMUM OUTSIDE DIAMETER (INCH)	MAXIMUM WEIGHT (LBS/1000 FT)
2	20	.166	15.0
	18	.188	20.9
	16	.202	25.0
	14	.234	35.3
	12	.276	52.6
3	20	.178	22.4
	18	.201	31.1
	16	.217	36.8
	14	.255	52.5
	12	.296	77.9
4	20	.221	28.4
	18	.251	39.9
	16	.274	48.6
	14	.318	69.0
	12	.371	102.3
5	20	.239	34.8
	18	.276	50.0
	16	.297	60.1
	14	.345	85.6
	12	.404	126.8

TYPE XVII CABLE

Figure 17

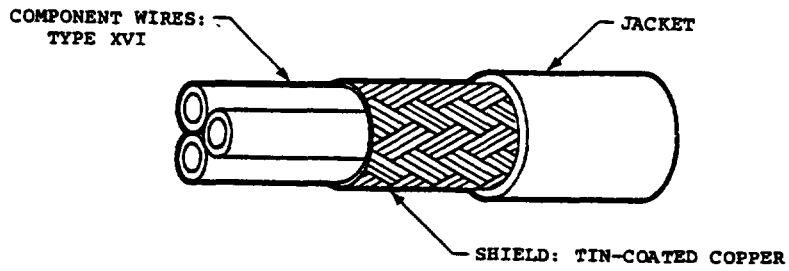

(TYPICAL FOR ALL CLASSES)

CLASS	CONDUCTOR SIZE (AWG)	MAXIMUM OUTSIDE DIAMETER (INCH)	MAXIMUM WEIGHT (LBS/1000 FT)
1	20	.110	12.3
	18	.121	15.7
	16	.128	18.4
	14	.144	24.1
	12	.163	33.6
2	20	.183	21.9
	18	.205	28.4
	16	.219	33.6
	14	.251	44.8
	12	.293	64.3
3	20	.195	30.1
	18	.218	39.8
	16	.234	46.7
	14	.272	64.2
	12	.313	91.5
4	20	.238	37.6
	18	.272	50.8
	16	.291	60.0
	14	.335	81.9
	12	.390	117.9

TYPE XVIII CABLE

Figure 18

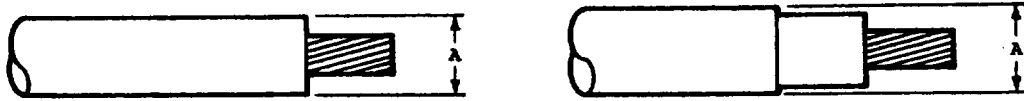

SINGLE EXTRUSION

COATED, SINGLE EXTRUSION



DUAL EXTRUSION

CLASS	CONDUCTOR SIZE (AWG)	A INCH MAX.	MAXIMUM WEIGHT (LBS/1000 FT)
1	20	.073	5.9
	18	.084	8.6
	16	.091	10.5
2	20	.146 1	11.9
	18	.168	17.3
	16	.182	21.2
3	20	.158 1	17.9
	18	.181	26.1
	16	.197	31.8
4	20	.201 1	23.9
	18	.231	34.8
	16	.250	42.5
5	20	.219 1	29.9
	18	.252	43.6
	16	.273	53.2
6	20	.219 1	36.0
	18	.252	52.4
	16	.273	64.0
7	20	.219 1	41.9
	18	.252	61.0
	16	.273	74.5
8	20	.292 1	48.0
	18	.336	69.9
	16	.364	85.3

1 Cable maximum outside diameter

TYPE XIX WIRE AND CABLE

Figure 19

4.4.5 (Continued)

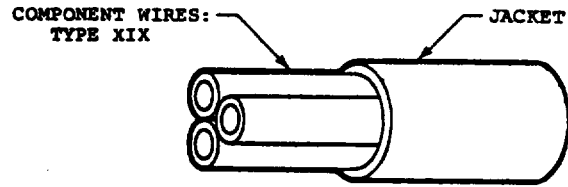

(TYPICAL FOR ALL CLASSES)

CLASS	CONDUCTOR SIZE (AWG)	MAXIMUM OUTSIDE DIAMETER (INCH)	MAXIMUM WEIGHT (LBS/1000 FT)
2	20	.166	15.0
	18	.188	20.9
3	20	.178	22.4
	18	.201	31.1
4	20	.221	28.4
	18	.251	39.9
5	20	.239	34.8
	18	.276	50.0

TYPE XX CABLE

Figure 20

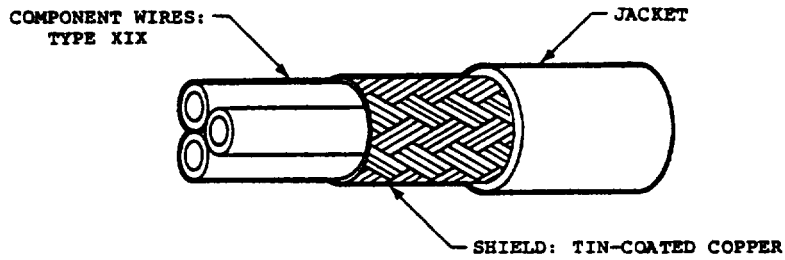

(TYPICAL FOR ALL CLASSES)

CLASS	CONDUCTOR SIZE (AWG)	MAXIMUM OUTSIDE DIAMETER (INCH)	MAXIMUM WEIGHT (LBS/1000 FT)
1	20	.108	12.3
	18	.121	15.7
2	20	.183	21.9
	18	.205	28.4
3	20	.195	30.1
	18	.218	39.8
4	20	.238	37.6
	18	.272	50.8

TYPE XXI CABLE

Figure 21



SINGLE EXTRUSION



COATED, SINGLE EXTRUSION



DUAL EXTRUSION

CLASS	CONDUCTOR SIZE (AWG)	A INCH MAX.	MAXIMUM WEIGHT (LBS/1000 FT)
1	24	0.059	3.2
	22	0.065	4.2
	20	0.073	5.9
	18	0.084	8.6
	16	0.091	10.5
2	24	0.118 ¹	6.5
	22	0.130	8.5
	20	0.146	11.9
	18	0.168	17.3
	16	0.182	21.2
3	24	0.127 ¹	9.7
	22	0.140	12.7
	20	0.158	17.9
	18	0.181	26.1
	16	0.197	31.8
4	24	0.162 ¹	13.0
	22	0.179	17.0
	20	0.201	23.9
	18	0.231	34.8
	16	0.250	42.5

¹ Cable maximum outside diameter.

TYPE XXII WIRE AND CABLE

Figure 22

4.4.5 (Continued)



SINGLE EXTRUSION



COATED, SINGLE EXTRUSION



DUAL EXTRUSION

CLASS	CONDUCTOR SIZE (AWG)	A INCH MAX.	MAXIMUM WEIGHT (LBS/1000 FT)
1	24	0.047	2.3
	22	0.054	3.4
	20	0.062	5.0
	18	0.073	7.5
	16	0.082	9.5
2	24	0.094 ¹	4.6
	22	0.108	6.9
	20	0.124	10.1
	18	0.146	15.1
	16	0.164	19.2
3	24	0.102 ¹	7.0
	22	0.117	10.3
	20	0.134	15.2
	18	0.158	22.7
	16	0.177	28.8
4	24	0.129 ¹	9.3
	22	0.149	13.8
	20	0.171	20.2
	18	0.201	30.4
	16	0.226	38.5

¹ Cable maximum outside diameter.

TYPE XXIII WIRE AND CABLE

Figure 23

4.4.5 (Continued)

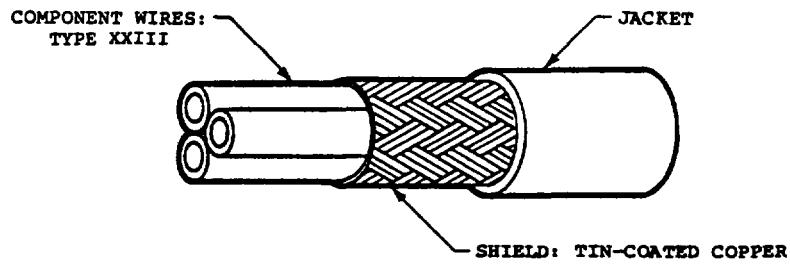

(TYPICAL FOR ALL CLASSES)

CLASS	CONDUCTOR SIZE (AWG)	MAXIMUM OUTSIDE DIAMETER (INCH)	MAXIMUM WEIGHT (LBS/1000 FT)
1	24	0.083	6.3
	22	0.089	8.0
	20	0.097	10.1
	18	0.109	13.5
	16	0.117	16.3
2	24	0.129	11.0
	22	0.141	14.1
	20	0.158	18.4
	18	0.180	24.9
	16	0.196	29.4
3	24	0.136	14.4
	22	0.149	18.8
	20	0.167	25.0
	18	0.191	33.6
	16	0.209	41.1
4	24	0.149	17.6
	22	0.164	23.6
	20	0.184	31.2
	18	0.211	43.3
	16	0.233	52.9

TYPE XXIV CABLE

Figure 24

4.5 PERFORMANCE REQUIRE

4.5.1 DESIGN AND PERFORMANCE

4.5.1.1 Accelerated Aging and Life Cycle

4.5.1.1.1 Life Cycle

4.5.1.1.1.1 Finished Wire

Specimens of wire which have been conditioned in accordance with Section 7.1.1.1.1 shall show no cracking of the insulation when removed from the oven and flexed. The straight specimens shall not exhibit insulation dripping or deformation which reduces the concentricity to less than 40 percent. No dielectric breakdown shall occur when tested in accordance with Section 7.1.11. Darkening of the conductor coating caused by normal air oxidation during aging shall not be cause for rejection.

4.5.1.1.1.2 Finished Cable

A specimen of cable which has been conditioned in accordance with Section 7.1.1.1.2 shall show no cracking of the cable jacket when flexed or wrapped around a 25X mandrel. No dielectric breakdown shall occur when tested in accordance with Section 7.1.11. Darkening of the conductor, or shield coating caused by normal oxidation during aging shall not be cause for rejection.

4.5.1.1.2 Accelerated Aging

4.5.1.1.2.1 Finished Wire and Cable

The specimens of wire and cable which have been conditioned in accordance with Section 7.1.1.2.1 shall show no evidence of cracking or dripping of the insulation. Concentricity shall not be less than 40 percent. When removed from the oven and flexed, no cracking shall occur. The cable shall not crack when wrapped 360 degrees around a 25X mandrel. No dielectric breakdown shall result when the specimens are tested in accordance with Section 7.1.11. Darkening of the conductor, or shield coating or the insulation shall not be cause for rejection.

4.5.1.2 Blocking

When tested in accordance with Section 7.1.2, the adjacent turns or layers of the wire shall not adhere to one another and the wire shall not be deformed to the degree that it fails to pass the Wet Dielectric and Insulation Resistance tests of Sections 7.1.11 and 7.1.18, respectively.

4.5.1.3 Cold Bend

The wire and cable shall withstand a temperature of $-65 \pm 2C$ without cracking of the insulation or jacket as viewed visually without magnification when tested in accordance with Section 7.1.3. The specimen shall then pass the Wet Dielectric test of Section 7.1.11.

4.5.1.4 Concentricity

The concentricity of the insulation material of the finished wire and cable shall be 70 percent (minimum) when tested in accordance with Section 7.1.4.

4.5.1.5 Conductor Direct Current Resistance

The resistance of the conductor shall be no greater than the values indicated in Table II of this specification when measured in accordance with Section 7.1.5.

4.5.1.6 Conductor Elongation and Tensile Strength

The individual strands of the conductor or the whole conductor removed from the finished wire shall have the following minimum elongation when measured in accordance with Section 7.1.6.

Soft annealed copper sizes 24 and 26	6 percent
Soft annealed copper sizes 22 and larger	10 percent
High-strength copper alloy	6 percent

4.5.1.6 (Continued)

When high-strength copper alloy is specified, the individual strands of the conductor, or the whole conductor removed from the finished wire, shall have a minimum tensile strength of 58,000 psi when measured in accordance with Section 7.1.6.

4.5.1.7 Current Overload

- a. The wire specimens when tested in accordance with Section 7.1.7.1, shall show no signs of insulation dripping or deformation which reduces the insulation concentricity to less than 40 percent when current is applied for five minutes. Post dielectric withstand values specified in Table XII, Section 7.1.7, shall be met.
- b. The two-foot long bundles, when tested in accordance with Section 7.1.7.2 shall incur no blocking or sticking sufficient to result in the bundle's failure to pass subsequent Dry Dielectric test.

4.5.1.8 Deformation

When conditioned and tested per Section 7.1.8, the wire shall meet the following requirements:

- a. The finished wire shall pass the Dielectric Withstand requirements indicated in the applicable section of Table III.
- b. The deformation of the wire outside diameters shall not be more than shown in Table III.

TABLE III
DEFORMATION

WIRE SIZE	TYPE	DIELECTRIC WITHSTAND KV			DEFORMATION PERCENT MAX		
		50 ± 3C	100 ± 3C	150 ± 3C	50 ± 3C	100 ± 3C	150 ± 3C
24	V	5.0	3.0	2.0	20.0	25.0	30.0
20	VIII	7.0	6.0	4.0	25.0	30.0	35.0
14	VIII	9.0	7.0	5.0	25.0	30.0	35.0
8	VIII	10.0	8.0	6.0	12.0	15.0	18.0
1/0	VIII	10.0	8.0	6.0	12.0	15.0	18.0
20	XVI	8.0	6.5	4.5	25.0	30.0	35.0
14	XVI	9.5	7.5	5.5	20.0	25.0	30.0

4.5.1.9 Dielectric

4.5.1.9.1 Impulse Dielectric

One hundred percent of the finished wire and cable listed below shall withstand the Impulse Dielectric test of Section 7.1.9, without dielectric breakdown, when exposed to the following impulse test voltage.

- a. Type I, V, IX, X, XI, XVI, XIX, XXII, and XXIII, all Classes and Sizes: 8Kv (Peak)
- b. Type VIII, all Classes, AWG size 26 through 10: 8Kv (Peak)
- c. Type VIII, all Classes, AWG size 8 through 4/0: 12Kv (Peak)
- d. Type III, VI, XII, XIII, XV, XVIII, XXI, and XXIV, all Classes and Sizes: 6Kv (Peak)

4.5.1.9.2 Dry Dielectric

One hundred percent of the Type III, IV, VI, VII, XII, XIII, XIV, XV, XVII, XVIII, XX, XXI, and XXIV finished cable shall withstand the Dry Dielectric test of Section 7.1.10, without breakdown, when a test voltage of 1500 volts (minimum) is applied.

4.5.1.9.3 Wet Dielectric

The specimen of finished wire shall withstand the Wet Dielectric test of Section 7.1.11 without dielectric breakdown when 2,500 volts (RMS) is applied for one minute.

4.5.1.10 (Continued)

4.5.1.10 Dynamic Cut-Through

When tested in accordance with Section 7.1.12 the finished wire shall meet the minimum cut-through requirements of Table IV.

TABLE IV
DYNAMIC CUT-THROUGH

WIRE SIZE	WIRE TYPE	POUNDS FORCE (MIN.)	
		23 + 3C	150 + 3C
24	V	10	4
20	VIII	25	6
14	VIII	50	10
8	VIII	100	15
1/0	VIII	400	125
20-2	XII	75	7
20	XVI	40	9
14	XVI	70	13

4.5.1.11 Flammability

When tested in accordance with Section 7.1.13, the finished wire shall meet the requirements listed in Table V.

TABLE V
FLAMMABILITY

TEST	FLAME TRAVEL MAXIMUM	PARTICLES	FLAME EXTINGUISH MAX.
60 Degree Test	3.00 Inch	None	5 Seconds
Vertical Test:			
Single Wire	5.00 Inch	None	5 Seconds
Bundle	3.00 Inch	None	5 Seconds

4.5.1.12 Flexure Endurance

4.5.1.12.1 Finished Wire

When tested in accordance with Section 7.1.14 both the insulation and the conductor shall withstand an average of 1000 cycles for Type VIII, and 1500 cycles for Type XVI and XIX.

The specimen shall be considered to have failed if either of the following occurs prior to achieving the required number of cycles.

- a. Cracking or breaking of the insulation so as to expose any part of the conductor.
- b. Breaking of the conductor so as to cause a loss of continuity of any duration.

4.5.1.12.2 Finished Cable

When tested in accordance with Section 7.1.14, the jacket shall not crack within 50 cycles. Where topcoat is used, cracks in the topcoat shall not constitute a failure.

4.5.1.13 Humidity Resistance

When tested in accordance with Section 7.1.15, the finished wire shall have an Insulation Resistance of not less than 5000 megohms per 1000 feet after 15 cycles of 71 + 2C/38C at 95 + 5 percent relative humidity.

4.5.1.14 Immersion

When tested as specified in Section 7.1.16, the diameter of the finished wire shall not change more than five percent. There shall be no cracking of the insulation on bending at 23 + 3C using the mandrels of Table XV, and no dielectric breakdown shall occur when tested per Section 7.1.11. The specimens as indicated in Table XV shall pass the abrasion requirements of Section 4.5.1.20. Wire identification markings, installed per Section 7.2.3, shall remain legible (Ink Jet marks are not required to be fluid resistant).

4.5.1.15

Insulation Elongation and Tensile Strength

When tested in accordance with Section 7.1.17, the insulation shall have a tensile strength of 5000 psi (minimum) and elongation of 50 percent (minimum). The elongation shall be calculated using the difference between the gauge marks at the time of rupture and the original gauge marks, divided by the original gauge marks.

4.5.1.16

Insulation Resistance

When tested in accordance with Section 7.1.18, the insulation shall have a minimum resistance of 2500 megohms per 1000 feet at $23 \pm 3C$.

4.5.1.17

Insulation Shrinkage or Elongation and Delamination

Shrinkage or elongation of the insulation measured at both ends of a 12 inch specimen of wire shall not exceed .06 inch at either end when conditioned in accordance with Section 7.1.19. There shall be no visible delamination of any protective coating. Color shall remain within the light and dark limits of MIL-STD-104.

4.5.1.18

Notch Sensitivity

When prepared and tested in accordance with Section 7.1.20 no dielectric failure shall occur.

4.5.1.19

Polyimide Cure

The wire insulation, or jacket, including the aromatic polyimide coating, shall show no visual evidence of cracking or delamination after testing in accordance with Section 7.1.21.

4.5.1.20

Scrape Abrasion Resistance

The insulation scrape abrasion resistance during any portion of the test, shall meet or exceed the values shown in Table VI when tested in accordance with Section 7.1.22.

TABLE VI

SCRAPE

WIRE SIZE	TYPE	MINIMUM CYCLES
24	V	20
20	VIII	50
14	VIII	100
8	VIII	150
1/0	VIII	500
20	XVI	63
14	XVI	125

4.5.1.21

Shield Coverage

The shield coverage, as determined by the method presented in Section 7.1.23, shall be a minimum of 85 percent. The angle of the shield carriers with the axis of the wire shall be between 20 and 35 degrees.

4.5.1.22

Smoke

4.5.1.22.1

Horizontal-Current Heating Test

The finished wire shall not give off visible smoke when conditioned and tested in accordance with Section 7.1.24.1. The conditioned wire specimen shall meet the Insulation Resistance requirements of Section 4.5.1.16 prior to and after the Wet Dielectric test of Section 7.1.11.

4.5.1.22.2

NBS Chamber Test

When tested per Section 7.1.24.2, the maximum Specific Optical Density (D_s) of the smoke shall not exceed 50 after 4 minutes.

4.5.1.23

Surface Resistance

The finished wire shall have a surface resistance of not less than five megohm/inch when tested in accordance with Section 7.1.25.

4.5.1.24

Tape Abrasion Resistance

The insulation abrasion resistance of the finished wire shall not be less than the values shown in Table VII when tested in accordance with Section 7.1.26.

TABLE VII
TAPE ABRASION

WIRE SIZE AWG	TYPE	MINIMUM RESISTANCE INCH OF TAPE
24	V	10
20	VIII	35
14	VIII	35
8	VIII	50
1/0	VIII	100
20	XVI	43
14	XVI	43

4.5.1.25

Thermal Shock Resistance

When tested in accordance with Section 7.1.27, the insulation of the finished wire shall not shrink or elongate more than .06 inch for size 20 and 14, .10 inch for size 8, and .125 inch for sizes 1/0, and Type XII, CL 2, AWG 20.

4.5.1.26

Weight

The weight of each lot of finished wire and cable, as determined by the method of Section 7.1.28, shall not exceed the maximum weight for the respective wire or cable sizes specified in Figures 1 through 24.

4.5.1.27

Wicking

When tested in accordance with Section 7.1.29, the indicator solution shall not wick a distance of more than 0.250 inch beyond the 2 inch immersion depth between any layers or components in the insulation.

4.5.1.28

Wire to Wire Abrasion

When tested in accordance with Section 7.1.30, the minimum acceptable number of cycles to failure shall be as shown in Table VIII.

TABLE VIII
WIRE TO WIRE ABRASION

TYPE	MASS ON FREE END OF WIRE	CYCLES TO FAILURE MINIMUM
VIII	1 pound	18,500,000
VIII	2.5 pound	6,150,000
VIII	5.0 pound	2,850,000
XVI	2.5 pound	10,000,000
XVI	5.0 pound	4,000,000

4.5.1.29

Wrap-Test

There shall be no insulation wrinkling, cracking, or dielectric breakdown when prepared, conditioned, and tested in accordance with Section 7.1.31.

4.5.2

HANDLING, ASSEMBLY, AND INSTALLATION

4.5.2.1

Flexibility

When tested per Section 7.2.1, flex forces and angular springback values of Table IX shall not be exceeded when the wires are bent around the test fixture mandrels to 90 and 180 degrees.

4.5.2.1 (Continued)

TABLE IX
FLEXIBILITY

WIRE SIZE AWG	TYPE	FLEX. FORCES - MAX.		SPRINGBACK ANGLE MAXIMUM
		90 Degrees	180 Degrees	
24	V	4.0 in. oz.	4.0 in. oz.	90 degrees
20	VIII	10.0 in. oz.	12.0 in. oz.	60 degrees
14	VIII	30.0 in. oz.	35.0 in. oz.	50 degrees
8	VIII	12.0 in. lbs.	15.0 in. lbs.	65 degrees
1/0	VIII	20.0 ft. lbs.	25.0 ft. lbs.	40 degrees
20	XVI	35.0 in. oz.	40.0 in. oz.	50 degrees
14	XVI	75.0 in. oz.	80.0 in. oz.	50 degrees

4.5.2.2 Durability of Product Identification

When tested in accordance with Section 7.2.2, the printed product identification coding, or the insulation or coating color, or color strip or band, applied by the manufacturer shall still be intelligible after 125 cycles.

4.5.2.3 Markability

The outer surface of the wire shall provide a finish that will retain a mark imprinted by hot stamping and ink jet marking, without a pre-etch by the user, when prepared and tested in accordance with Section 7.2.3. No portion of any character shall be completely rubbed through after an average of 20 rubs. There shall be no dielectric breakdown at the marked areas, when tested in accordance with Section 7.1.11. When exposed to the 12 hour Weatherometer test of Section 7.2.3.2.2 the ink jet mark must remain intelligible. Hot stamp markings must be fluid resistant as specified in Section 4.5.1.14. Fluid immersion is not required for ink-jet specimens.

4.5.2.4 Insulation Removal

The force required to remove a 1/4 inch slug of insulation from each end of a wire with a nominal wall thickness of 10 mils or less, shall not exceed three pounds for wire size AWG 24 and AWG 20, and four pounds for wire size AWG 14 when tested per Section 7.2.4. The strip force for wire with a nominal wall thickness of 15 mils shall not exceed five pounds for AWG 24 and 20, and six pounds for AWG 14. The conductor shall not splay when the insulation is removed.

4.5.3 PRODUCT CONTROL

4.5.3.1 Jacket Flaw

One hundred percent of the Type III, VI, XII, XIII, XV, XVIII, and XXI finished cable shall pass the Jacket Flaw test of Section 7.3.1 without breakdown. Either the Procedure I Spark test using a voltage of 1.0 Kv to 1.5 Kv, or the procedure II Impulse Dielectric test using a voltage of 6 kv is acceptable.

4.5.3.2 Workmanship

The finished wire or cable shall be uniform in every respect, free of all irregularities, lumps, bumps, voids, foreign material and abraded surfaces. It shall consistently meet the requirements of this specification when tested in accordance with Section 7. This requirement shall be applicable where specific requirements are not defined in this specification.

4.5.3.3 Visual and Dimensional

Visual and dimensional inspection of the minimum areas outlined in Section 7.3.3 shall verify that the finished product conforms to all the physical requirements described in this specification.

5. VENDOR QUALIFICATION

Wire and cable of this specification shall be subject to approval by all using Company Engineering Departments of The Boeing Company.

5.1 QUALIFICATION REQUEST

A manufacturer's request to submit his product for approval under this specification shall be directed to the Engineering Department of the using Company of The Boeing Company through the Materiel Section or Department of that Company.

After receiving written authorization from the Materiel Section, the manufacturer shall submit the reports and materials required in Section 5.3 and 5.4.

5.2 QUALIFICATION TEST

The finished wire or cable of Section 5.4 shall meet all the requirements specified in Section 4. of this specification. The qualification tests shall consist of all the tests listed in Table XX, and detailed in Section 7, as applicable to wire or to cable.

5.3 QUALIFICATION REPORT

The manufacturer shall submit six copies of a report certified by a responsible engineer or officer of the company, which shall contain the following:

- a. The quantitative results of all of the qualification tests on all of the qualification specimens. These results shall verify that the basic wire and finished cable specimens satisfactorily passed all of the qualification requirements of this specification.
- b. Detailed description of test methods.
- c. Physical details of each size of each Type and Class of wire or cable which shall include the following:
 - (1) Manufacturer's Part Number
 - (2) Detailed description of construction.
 - (3) Maximum production weights and diameters of finished wire.
 - (4) Actual weights and diameters of wire tested.

5.4 QUALIFICATION MATERIALS

For qualification tests, the manufacturer submitting his product for approval shall supply the following:

- a. 750 feet each of Type VIII, Class 1, AWG 20, 14, and 8 wire.
- b. 600 feet of Type VIII, Class 1, AWG 1/0.
- c. 750 feet of Type V, class 1, AWG 24 wire.
- d. 350 feet of Type XII, class 2, AWG 20 wire.
- e. 750 feet each of Type XVI, Class 1, AWG 20 and 14 wire.
- f. 50 feet of Type XIX, Class 1, AWG 20 wire.
- g. 50 feet of Type XXII, Class 1, AWG 20 wire.

5.5 SUPPLIER QUALITY CONTROL

Unless otherwise specified, samples of sufficient length shall be selected at random from each inspection lot of finished wire or cable to provide at least three specimens for each of the supplier tests. An inspection lot shall be defined as one manufacturing lot, not to exceed 100,000 feet. A manufacturing lot shall be defined as each type, class and size of wire or cable produced in one continuous operation, under the same conditions, and on the same equipment.

5.5.1 SUPPLIER INSPECTION TEST

The Supplier Inspection tests shall consist of the tests as indicated in Table XXI, and detailed in Sections 4.5 and 7.

5.5.2 SUPPLIER INSPECTION TEST REPORTS

Each shipment of finished wire or cable shall be accompanied by a test report identified by lot number and purchase order number. A duplicate of this report shall be mailed to the purchaser, attention of buyer whose name appears on the purchase order, on or before the day of each shipment. The report shall include the following items:

5.5.2

(Continued)

- a. Detail the average production weight (or weights), determined for the supplier's inspection lot (lots) of finished wire or cable from which this shipment was taken, in pounds per 1000 feet.
- b. Certification that the finished wire or cable has been manufactured in accordance with the requirements of this specification and that the supplier's inspection lot (or lots) of wire and cable from which this shipment was taken has successfully passed the supplier tests.
- c. Construction details, i.e., dual extrusion, braided single extrusion, etc.
- d. Verification that lengths supplied are per specification.
- e. Quantitative results of all inspection tests.

The manufacturer shall keep the quantitative results of all inspection tests on file and available to authorized representative of the Boeing Company for two years after delivery of the finished wire or cable.

5.6

PRODUCT APPROVAL

Approval granted to this specification will be contingent upon the following conditions:

- a. A manufacturer shall be prepared to produce all Types, Classes and Sizes of wire and cable approved to this specification.
- b. After initial approval, changes in design, material, construction configuration or manufacturing methods shall not be made without written approval from the using Company Engineering Department of The Boeing Company.
- c. Each manufacturer will be listed in the QPL as approved to supply only those constructions which have been granted qualification approval. Each manufacturer can supply only those constructions for which the manufacturer is listed in the QPL, and which are described in detail in the QPL Qualified Supplier Sheets.
- d. Deviations from the requirements of this specification without prior written authorization from each of the using Company Engineering Departments of The Boeing Company, shall be cause for rejection of wire and cable, and removal of a vendor's name as an approved source.

5.7

QUALIFIED PARTS LIST (QPL)

Each supplier whose products have been proven to satisfy all of the requirements herein will be added to the QPL. When the supplier is added, a two digit Qualified Supplier Sheet (QSS) number will be assigned governing the particular construction which has been qualified. This QSS number will be used by the manufacturer as part of the wire identification code (see paragraphs 8.1 and 8.2). The QSS number will also be assigned to a set of drawings containing the information described in Section 5.5.2.c. These drawings will become a part of the QPL, and shall be the requirements against which Visual and Dimensional Inspection shall be conducted.

6.

PURCHASER ACCEPTANCE

6.1

RECEIVING INSPECTION TESTS

Random samples of each Type, Class and Size shall be selected from each supplier's production wire shipment. Each sample shall be of sufficient length to conduct all acceptance tests.

The purchaser will subject each supplier manufacturing lot of wire or cable received within a shipment to the Visual and Dimensional test of Section 7.3.3. If the product received employs a "Polyimide Topcoat," the Polyimide Cure test of Section 7.1.21 is also required. However, this polyimide cure test may be conducted on a sampling basis at the discretion of Quality Control. The purchaser may subject said wire or cable to any test listed in Table XX, if deemed necessary by Quality Control, to assure that the material meets the requirements of this specification.

6.2

SOURCE INSPECTION

When buyer elects to perform inspection at the supplier's facility, paragraph 6.1 is optional.

6.3

ACCEPTANCE, REJECTION AND RETEST

Failure of any test specimen to pass the requirements of a specified test shall be cause for rejection of that type, class or size of wire or cable contained in the specific shipment. Action in case of failure shall be in accordance with MIL-STD-105.

7. TEST METHOD

All samples of wire and cable shall be examined carefully to determine conformance to this specification.

NOTE: All tests will be conducted at an ambient temperature of $23 \pm 3C$ unless otherwise stated in the specific test methods.

7.1 DESIGN AND PERFORMANCE

7.1.1 ACCELERATED AGING AND LIFE CYCLE

7.1.1.1 Life Cycle

7.1.1.1.1 Finished Wire

One inch of the insulation shall be removed from each end of a 24 inch sample of the finished wire. The central portion of the specimen shall then be bent at least halfway around a cylindrical mandrel having a diameter as specified in Table X. Each end of the conductor shall be loaded in such a manner that the portion of the insulation between the conductor and mandrel is under compression while the conductor is under the tension specified in Table X. Specimens of suitable length shall be suspended horizontally and held taut over mandrels and weights of Table X such that a minimum horizontal length of 18 inches is attained. These specimens so prepared shall be placed in an air circulating oven. The velocity of air past the specimen (measured at room temperature) shall be between 100 and 200 feet per minute. The oven shall be adjusted such that the temperature cycles is as follows: Fifteen hours at $200 \pm 5C$ followed by 6 hours during which the oven is allowed to cool to room temperature ($23 \pm 5C$). This cycle will then be repeated until a total of 8 cycles (168 hours) have been completed. After completion of the air oven conditioning, the specimen shall be cooled to a temperature of $23 \pm 5C$ within a period of one hour. When cool, the wire shall be relieved of tension, removed from the mandrel, and straightened as applicable. The specimens shall then be subjected to the Wet Dielectric test described in Section 7.1.11.

7.1.1.1.2 Finished Cable

The length of the specimen to be tested shall be 24 inches. Two inches of the jacket shall be removed from each end of a shielded specimen. The specimens shall be hung freely in the conditioning chamber. The specimens shall then be conditioned, tested, and cooled as in Section 7.1.1.1.1. When cool, the center portion of the specimen shall be wrapped a minimum of 180 degrees around a mandrel with a diameter 25 times the overall diameter of the finished cable. The specimen shall then be visually examined, without aid of magnification. The specimen shall then be subjected to the Wet Dielectric test described in Section 7.1.11. The bent portion of the specimen is to be submerged during Wet Dielectric tests.

TABLE X
ACCELERATED AGING AND LIFE CYCLE

WIRE SIZE AWG	WIRE TYPE	MANDREL DIAMETER INCH	WEIGHT POUNDS
24	V	0.5	0.5
20	VIII	0.75	2.0
14	VIII	1.00	3.0
8	VIII	3.0	4.0
1/0	VIII	8.0	6.0
20	XVI	1.00	3.0
14	XVI	1.25	3.5

1 For horizontal tests a one inch mandrel may be used for all wire sizes.

7.1.1.2 Accelerated Aging

7.1.1.2.1 Finished Wire and Cable

Prepare specimens and place in an air circulating oven as in Section 7.1.1.1.1 and 7.1.1.1.2. Condition the specimens at $250 \pm 3C$ for a period of seven hours. After conditioning is complete, cool the specimens to room temperature within a one hour period. Wrap the cable specimens around a 25X mandrel a minimum of 180 degrees. Inspect all specimens for cracks (flexing as required). Each specimen shall then pass the Wet Dielectric test of Section 7.1.11.

7.1.2 BLOCKING

One end of a piece of finished wire, of sufficient length to perform the test, shall be affixed to a metal spool with a barrel diameter 4.0 inches for AWG 26 thru 10 and 9.5 inches for AWG 8 thru 4/0. The wire shall then be wound helically on the spool for at least three turns, with the succeeding turns in close contact with one another. The tension for winding shall be equal to the test load specified in Table XI.

The winding shall be continued until there are at least three closely-wound layers of such helical turns on the spool. The free end of the wire shall then be affixed to the spool so as to prevent unwinding or loosening of the turns or layers and the spool and wire shall be placed for 24 hours in an air circulating oven at $200 \pm 5C$. The velocity of air past the specimen (measured at room temperature) shall be between 100 and 200 feet per minute. At the end of the 24 hour period, the spool and wire shall be removed from the oven and allowed to cool to room temperature. After cooling, the wire shall be unwound manually, while being examined for evidence of blocking of adjacent turns or layers. Blocking shall consist of the transfer of insulation, jacket material, or topcoat, as applicable, from one turn or layer to another. The samples shall be subjected to the Wet Dielectric test of Section 7.1.11 followed by the Insulation Resistance test of Section 7.1.18.

7.1.3 COLD BEND

7.1.3.1 Finished Wire

One end of a previously untested wire specimen of suitable length shall be secured to a mandrel in a cold chamber and the other end to the load weight specified in Table XI. The specimen of wire and the mandrel shall be conditioned at $-65 \pm 2C$ for four hours. At the end of this period and while both mandrel and specimen are still at this low temperature, the specimen shall be wrapped for two turns around the mandrel without opening the chamber. The bending shall be accomplished at a uniform rate of speed of 2 RPM. A revolving mandrel operating externally from the chamber shall be used. At the completion of this test, the specimen shall be removed from the cold box and from the mandrel without straightening. The insulation shall be removed for a distance of one inch from each end of the specimen, and the specimen shall be subjected to the Wet Dielectric test as specified in Section 7.1.11.

7.1.3.2 Finished Cable

Test as defined in Section 7.1.3.1, except that the cable shall be hung freely in the chamber. After conditioning, the cable shall be removed from the chamber, allowed to recover to room temperature, and wound for two turns on a mandrel approximately 25 times the nominal outside diameter of the finished cable. The cable shall then be subjected to the Wet Dielectric test of Section 7.1.7.3 with the bent portion submerged.

TABLE XI
COLD BEND TEST

WIRE SIZE	WIRE TYPE	MANDREL DIAMETER INCH MAXIMUM	TEST LOAD POUNDS
24	V	1.00	3
20	VIII	1.00	4
14	VIII	1.25	5
8	VIII	3.00	6
1/0	VIII	10.00	15
20	XVI	1.25	5.0
14	XVI	1.50	5.5

7.1.4 CONCENTRICITY

The percent concentricity of the insulation of the finished wire or cable jacket shall be defined as the ratio of the minimum wall thickness to the maximum wall thickness. All wall-thickness measurements shall be determined under suitable magnification. The wall thickness is the radial distance between the outer rim of the insulation and the outermost rim of the outermost strand of the conductor. Jacket wall thickness shall be the radial distance between the outer rim of the jacket and the outermost rim of the outermost shield strand or component wire.

7.1.5 CONDUCTOR DIRECT CURRENT RESISTANCE

The direct-current resistance of the conductor shall be measured for compliance with Table II of this specification using Method 6021 of FED-STD-228 to four significant figures. The wire shall be tested dry.

7.1.6 CONDUCTOR ELONGATION AND TENSILE STRENGTH

a. Elongation and tensile strength tests shall be performed on individual strands taken from the conductors of finished wire in accordance with Method 3211 of FED-STD-228 using a 12-inch specimen length, 10-inch bench marks, and a 10-inch initial jaw separation. Soft annealed copper shall be pulled at 10 inches per minute; high-strength copper alloy shall be pulled at two inches per minute.

b. Size 22 and Smaller

In case of failure to meet the required elongation, size 22 and smaller may be pulled as a whole conductor. The elongation and tensile strength shall be calculated from the values recorded when the first strand of the whole conductor breaks.

7.1.7 CURRENT OVERLOAD

7.1.7.1 Single Wire

Remove one half inch of the insulation from the ends of a two foot long wire specimen and suspend the specimen horizontally with no visible sag. Attach current leads to the uninsulated ends and apply current to the respective specimen, as listed in Table XII, for five minutes. Visual examination shall be recorded during the test and after the specimen has stabilized at room temperature.

Immediately following the examination and before dismantling the test set-up, subject the specimen to a post dielectric test. The dielectric test jig is illustrated in Figure 25. Place the bottom contact plate under the wire and make contact at the area with maximum deformation or with the center 12 inch of the specimen. The upper contact plate shall be placed on top of the specimen, directly over the bottom plate. Be certain that both plates make positive contact with the wire. The voltage shall be increased from zero to the voltage specified in Table XII at a uniform rate of 500 volts/second and maintained for one minute. Concentricity, as defined in Section 7.1.4, shall be checked at the center and at points two inches each side of center for each single wire specimen.

7.1.7.2 Bundles

Seven, two foot long wires of each qualification size shall be assembled to form a bundle consisting of a center core wire with six parallel wires surrounding it. Two power supplies shall be used to supply the test current; one for the core wire and the other for the outer wires. Apply current to the six outer wires per Table XII until the temperature has stabilized. With the other wires still energized, apply the applicable overload current to the center wire. Maintain current flow for a period of five minutes. After the current test, submit the bundle to a Dry Dielectric test per Section 7.1.10.

TABLE XII
CURRENT OVERLOAD

WIRE SIZE	WIRE TYPE	AMPERES APPLIED TO SINGLE (CORE) WIRES	AMPERES APPLIED TO OUTER WIRES IN A BUNDLES	POST DIELECTRIC WITHSTAND 1 MIN @ VAC
24	V	12	4.0	600
20	VIII	33	7.5	600
14	VIII	70	17.0	1000
8	VIII	220	46.0	1500
1/0	VIII	730	150.0	1500
20	XVI	33	7.5	1000
14	XVI	70	17.0	1500

7.1.8

DEFORMATION TEST

The deformation test shall be conducted at $50 \pm 3C$, and $150 \pm 3C$ using a test device as suggested in Figure 26.

- a. Length of specimen shall be long enough for conductor isolation from the ground.
- b. The weight (including the moving parts of the test assembly) applied to the wire shall be as specified in Table XIII.
- c. The diameter of the hardened steel mandrel shall be the same as the diameter of the test specimen plus or minus .005 inch.
- d. The dielectric withstand after one minute, and deformation measurement shall be made after 15 minutes impression time at each specified temperature.
- e. The tester may be placed in an oven or the test temperature may be maintained with a portable source, as shown in Figure 26.
- f. Deformation shall be defined as the difference between the initial and final dial indicator reading when expressed as a percentage of the original.

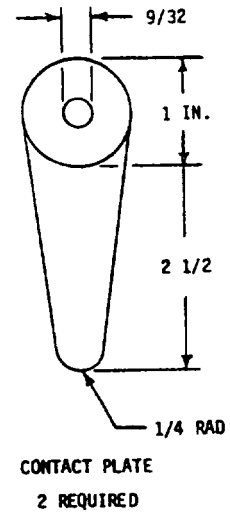
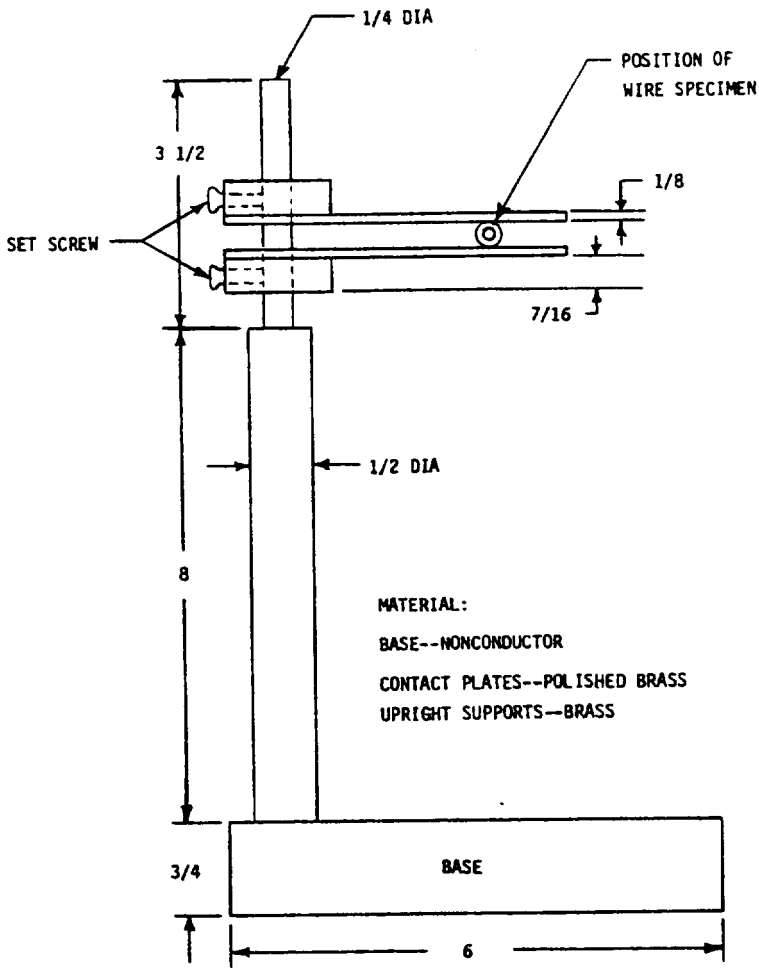

MATERIAL:
 BASE--NONCONDUCTOR
 CONTACT PLATES--POLISHED BRASS
 UPRIGHT SUPPORTS--BRASS

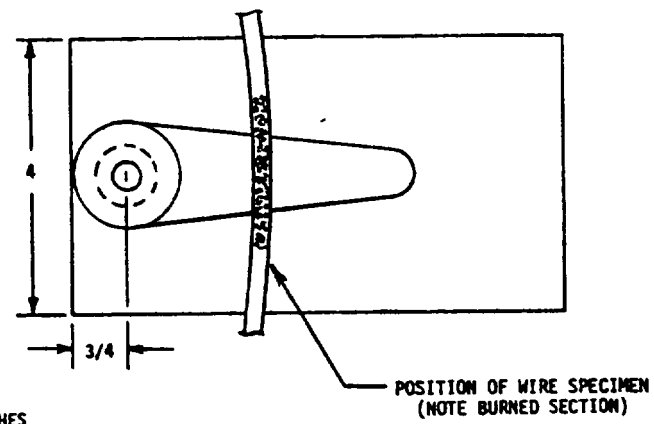

DIMENSIONS IN INCHES

DRY DIELECTRIC TEST JIG

FIGURE 25

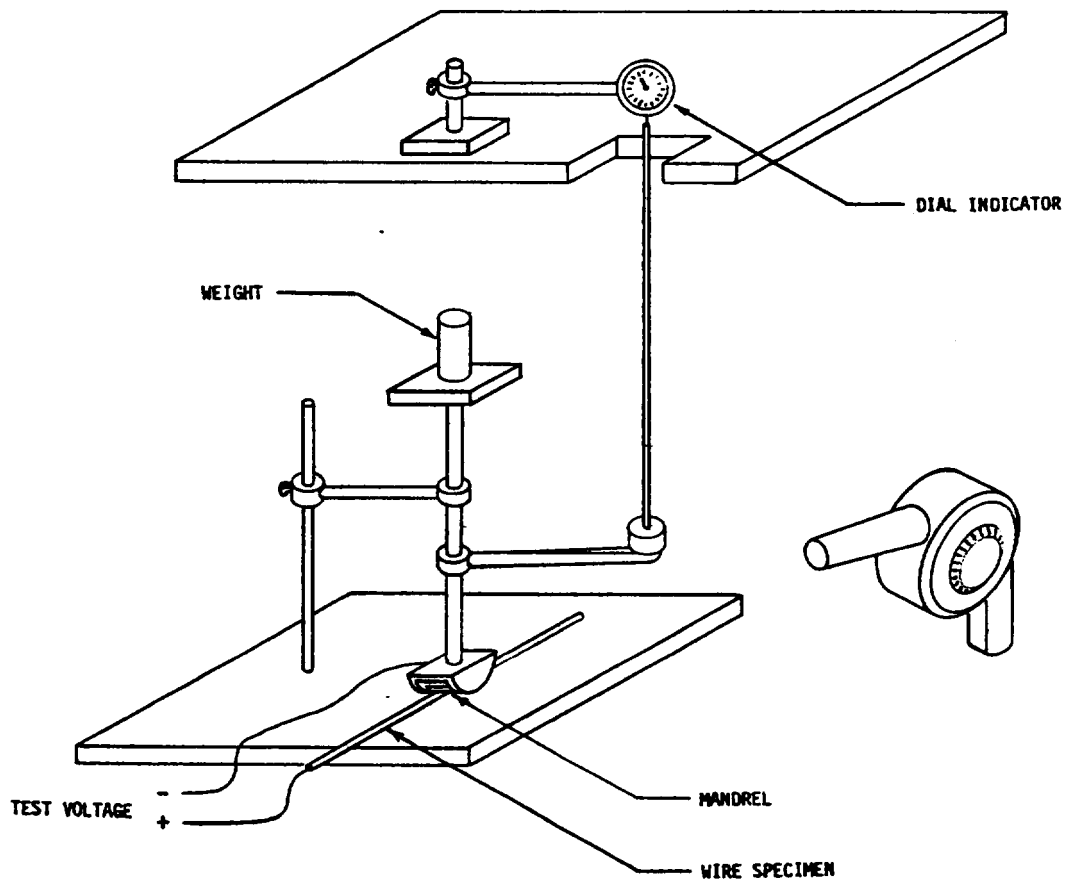

DEFORMATION TEST APPARATUS

FIGURE 26

TABLE XIII
DEFORMATION TEST

WIRE SIZE	TYPE	WEIGHT, POUNDS
24	V	3
20	VIII	5
14	VIII	8
8	VIII	15
1/0	VIII	15
20	XVI	6.5
14	XVI	9.5

7.1.9

IMPULSE DIELECTRIC

7.1.9.1

Test Equipment

The electrode head through which the wire or cable is passed in the impulse dielectric test shall be of a suitable bead-chain construction (Figure 27) such that the electrode will give intimate metallic contact with practically all of the wire or cable surface. The characteristics of the test impulse and of the equipment auxiliary to the electrode head shall be as follows:

- a. The waveform of the voltage supplied to the electrode head shall consist of a negative pulse, the peak magnitude of which shall be as specified for the wire or cable under test, followed by a damped oscillation. Unless otherwise specified, the peak impulse voltage shall be 8.0 Kv for AWG 26 thru 10, 12 Kv for AWG 8 thru 4/0, and 6.0 Kv for cable. The rise time of the negative impulse wave front from zero magnitude to 90 percent of the specified peak voltage shall be not more than 75 microseconds. The peak value of the first positive overshoot and each of the subsequent damped oscillations shall be smaller than the initial negative pulse. The time during which each pulse and accompanying damped oscillation (positive and negative) remains at an absolute potential of 80 percent or greater of the specified peak voltage shall be 20 to 100 microseconds. The pulse repetition rate shall be 200 to 250 pulses per second, inclusive. Except for the final peak voltage adjustment, conformity to these test impulse parameters shall be determined with no capacitive load impressed upon the electrode.
- b. **Capacitive Tolerance**
The tolerance of the equipment to change in capacitive load shall be such that the peak output voltage shall not be reduced by more than 12 percent in the event of an increase of capacitive load, between electrode and ground, from an initial load of 12.5 picofarads per inch to 25 picofarads per inch of electrode length.
- c. **Instrument Voltmeter**
Connected to the electrode head, there shall be a peak reading voltmeter indicating continually the potential of the electrode. The voltmeter shall show full deflection at a potential not exceeding 15 Kv, and shall have an accuracy of ± 4 percent at the specified test impulse potential.
- d. **Failure Detection Circuit**
There shall be a failure detection circuit to give a visible or audible indication of insulation failure, automatically de-energize the electrode head, and stop progress of the wire or cable through the electrode. The failure detection circuit shall be sufficiently sensitive to indicate a fault at 75 percent of the specified test voltage when the electrode is arced to ground through a 20 kilohm resistor, and shall be capable of detecting a fault which lasts for the duration of only one impulse.

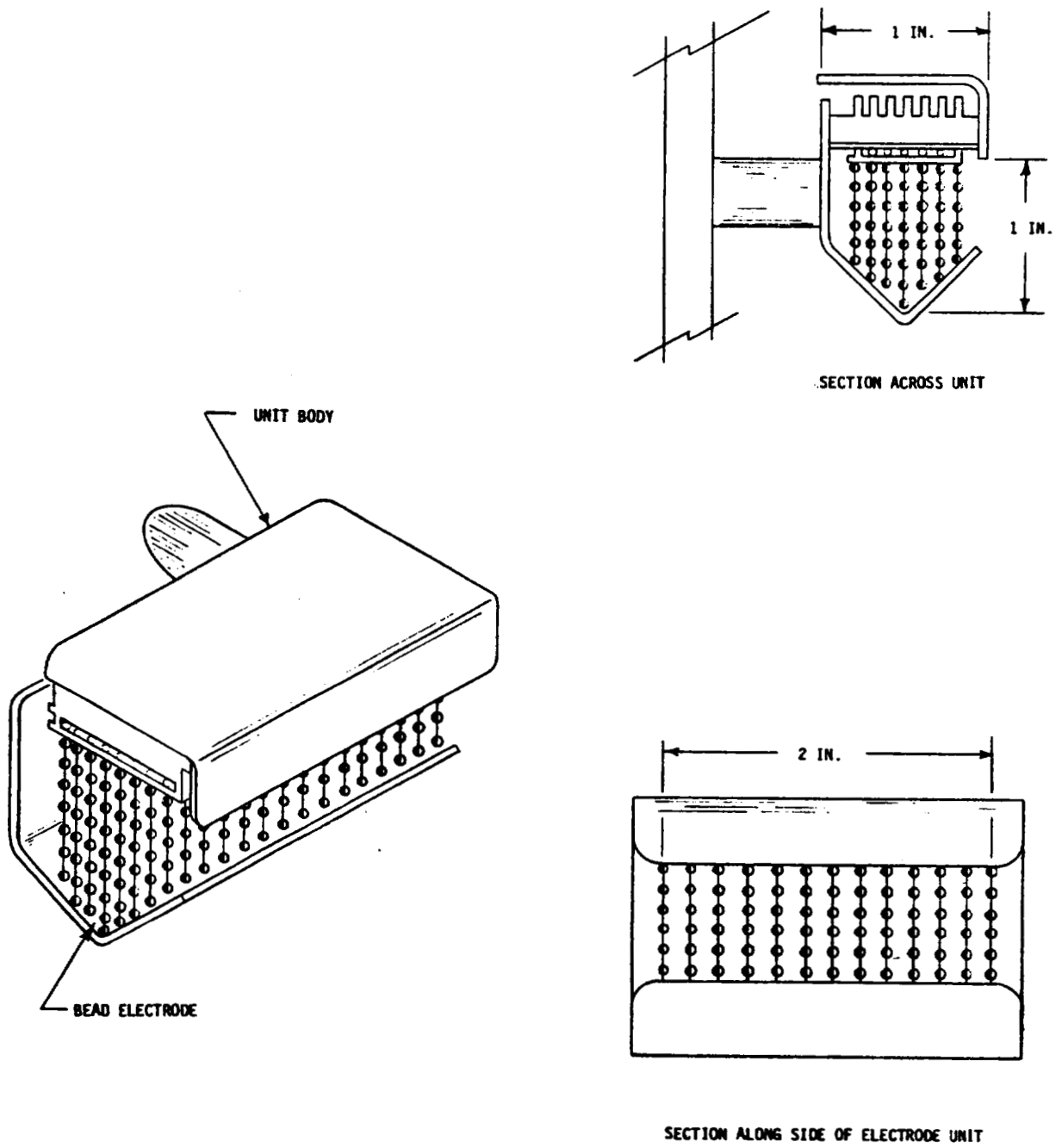

MINIATURE BEAD-CHAIN ELECTRODE HEAD FOR IMPULSE DIELECTRIC TEST

FIGURE 27

7.1.9.2

Calibration of Equipment

The instrument voltmeter shall be calibrated by comparison with an external standard voltmeter capable of detecting the peak potential at the electrode head with or without auxiliary circuitry. In performing the calibration, the standard voltmeter shall be connected to one of the electrode beads directly or through a calibrated attenuator circuit. The impulse generator shall be energized and the voltage control of the impulse generator shall be adjusted until the reading on the standard voltmeter is the specified potential, at which point the reading on the instrument voltmeter shall be observed and recorded. This calibration shall be repeated for each peak potential at which it is intended to operate the equipment. An alternative procedure is by means of a calibrated oscilloscope connected to the electrode through a suitable attenuator. The peak magnitude of the negative pulse can then be read directly from the waveform display. An oscilloscope connected to the electrode head at suitable test points shall also be used to verify conformance to the other waveform parameters specified in Section 7.1.9.1.(a).

7.1.9.3

Test Procedure

The finished wire or cable shall be threaded through the electrode head and the conductor or shield, as applicable, shall be grounded at one or both ends. The electrode shall be energized to the specified peak potential, and after final adjustment of the voltage with wire or cable in the electrode head, the wire or cable shall be passed from the pay-off spool through the electrode and onto the take-up spool. The speed of passage of the wire or cable through the electrode shall be such that the wire or cable is subjected to not less than 3 nor more than 100 pulses at any given point. Any dielectric failures which occur shall be cut out or marked for later removal along with at least two inches of wire or cable on each side of the failure. During all parts of the test, including string-up of new lengths, every effort shall be made to test the entire length, including ends of the wire or cable, in accordance with this procedure. All ends or other portions of the wire or cable not so tested shall be removed subsequent to the test.

7.1.10

DRY DIELECTRIC

Finished cables shall be subjected to a minimum potential of 1500 volts (rms) applied between each conductor and all other conductors of the cable connected together. If the specimen incorporates a shield the potential shall be applied between each conductor and all other conductors and the shield connected together. The potential shall be applied with room temperature at $23 \pm 3C$ for one minute without dielectric breakdown.

7.1.11

WET DIELECTRIC

The test specimen shall be immersed in a five percent saline solution at a temperature of $23 \pm 3C$ for four hours. The ends of the individual insulated wires shall extend at least six inches (four inches for short specimens), above the level of the liquid. At the end of this conditioning period, the specified potential of 2500 volts (rms) shall be applied for one minute between the conductor or shield (as applicable) and the electrode in the solution.

7.1.12

DYNAMIC CUT-THROUGH

7.1.12.1

Testing Apparatus

The dynamic cut-through test shall be performed using a tensile tester operating in a compression mode. The tester shall be equipped with a chart recorder which shall be suitable for recording the force necessary to force a tungsten carbide edge, as shown in Figure 28, through the insulation of a finished wire specimen. The tester shall also be equipped with a chamber, which will allow the test to be performed at elevated temperatures, and a 12-volt detection circuit designed to stop the tester when the tungsten carbide edge cuts through the wire insulation and contacts the conductor.

7.1.12.2

Testing Procedure

The test shall be conducted at temperatures of $23 \pm 3C$ and $150 \pm 3C$. One inch of insulation shall be removed from one end of the finished wire specimen. The cutting edge shall be moved through the insulation at a constant rate of 0.5 inch per minute until contact with conductor occurs. Four tests shall be performed on each specimen. The specimen shall be moved forward one inch, minimum, and rotated clockwise 90 degrees between each test. The cut-through force shall be the average of the four tests.

7.1.13

FLAMMABILITY

7.1.13.1

60 Degree Test

The test specimen shall be 24 inches in length and shall be marked 8 inches from the lower end to indicate the central point for flame application. The specimen shall be placed at an angle of 60 degrees with the horizontal within a chamber as described in Federal Aviation Regulation Part 25.1359. The specimen shall be parallel to and approximately six inches from the front of the chamber. The upper end of the specimen shall pass over a pulley and shall have a weight attached to it sufficient to hold the specimen taut throughout the flammability test. A piece of facial tissue conforming to Federal Specification UU-T-450, not less than 8 x 8 inches, shall be suspended tightly and horizontally. The tissue shall be centered 9-1/2 inches directly below the test mark on the specimen and at least 1/2 inch away from the table top. A flame from a Bunsen burner shall be applied for 30 seconds at the test mark. The Bunsen burner shall be mounted underneath the test mark on the specimen, perpendicular to the specimen, and at an angle of 30 degrees to the vertical plane of the specimen as shown in Figure 29. The Bunsen burner shall have a 1/4 inch inlet, a nominal bore of 3/8 inch, and a length of approximately 4 inches from top to primary inlets. The burner shall be adjusted to produce a 3-inch high flame with an inner cone approximately one-third of the flame height. The temperature of the hottest portion of the flame as measured with an accurate thermocouple pyrometer, shall be not less than 955C. The burner shall be positioned so that the hottest portion of the flame is applied to the test mark on the wire. The distance of flame travel upward along the wire from the test mark during and after flame impingment, and the time of burning after removal of the flame shall be recorded. Any burning particles or drippings which cause the tissue paper to burst into flame shall be recorded. Charred holes or charred spots in the tissue paper caused by burning particles do not constitute failure. Breaking of the wire specimen shall not be considered as a failure, however, test must be repeated.

7.1.13.2

Vertical Flame Test

Single Wire

The test specimen shall be 18 inches in length, and shall be placed vertically within a chamber approximately 2 x 1 x 1 foot, open at the top and one vertical side (front), which allows a sufficient flow of air for complete combustion, but which is free from drafts (per Federal Standard 191B, Method 5903). The upper end of the specimen shall be fastened in the chamber by means of a clamp, and a weight shall be attached to the lower end of the specimen to hold the specimen taut during the flammability test. The weights shall be those listed in Table X, Section 7.1.1.1.2. The specimen shall be marked at approximately seven inches above the floor of the chamber to indicate where the flame is to be applied.

A flame from a Bunsen burner shall be applied for 15 seconds to the specimen. The Bunsen burner shall be positioned below the test mark on the specimen, and at an angle of 20 degrees to the vertical plane of the specimen. The Bunsen burner shall have a 1/4 inch inlet, a nominal bore of 3/8 inch, and a length of approximately four inches from the top to primary inlets. The burner shall be adjusted to produce a three inch high flame with an inner cone approximately one-third of the flame height. The temperature of the hottest portion of the flame, as measured by a thermocouple pyrometer, shall be not less than 955C. The burner shall be positioned so that the hottest portion of the flame is applied to the approximate position of the test mark on the wire. The flame travel during and after flame impingment, and the time of burning after removal of the flame shall be recorded. Breaking of the wire specimen shall not be considered as a failure, however, test must be repeated.

Bundles

The test specimen shall be prepared by assembling 7 single wire specimens, each 14 inches long, into a bundle tied in two places with glass cord, or equivalent nonmetallic, noncombustible material, three inches from each end. The bundles shall be suspended vertically in the test chamber described above. A flame from a Bunsen burner shall be applied vertically to the base of the bundle for 15 seconds. The burner flame shall be adjusted as described for the single wire flame test. The flame travel during and after flame impingment, and the time of burning after flame removal shall be recorded.

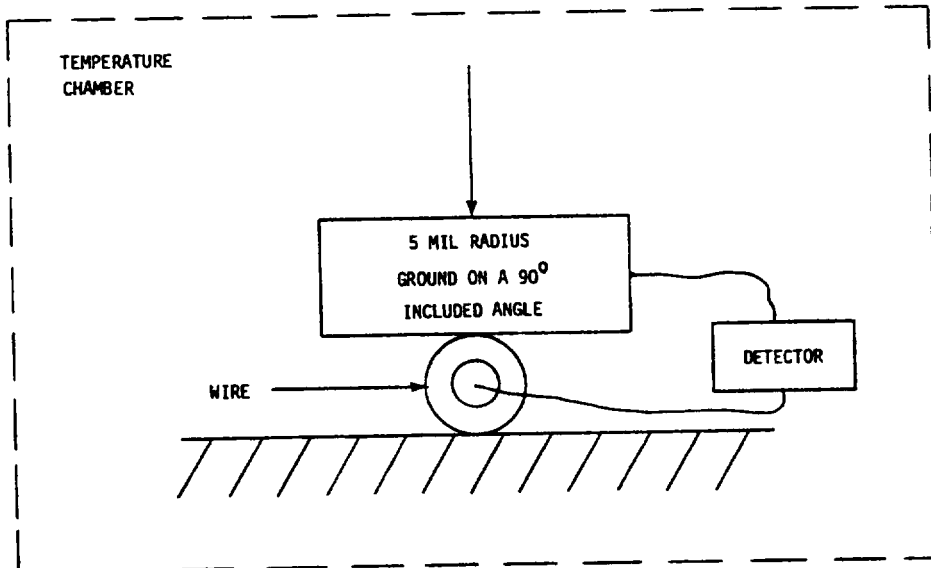

DYNAMIC CUT-THROUGH TEST SET UP

FIGURE 28

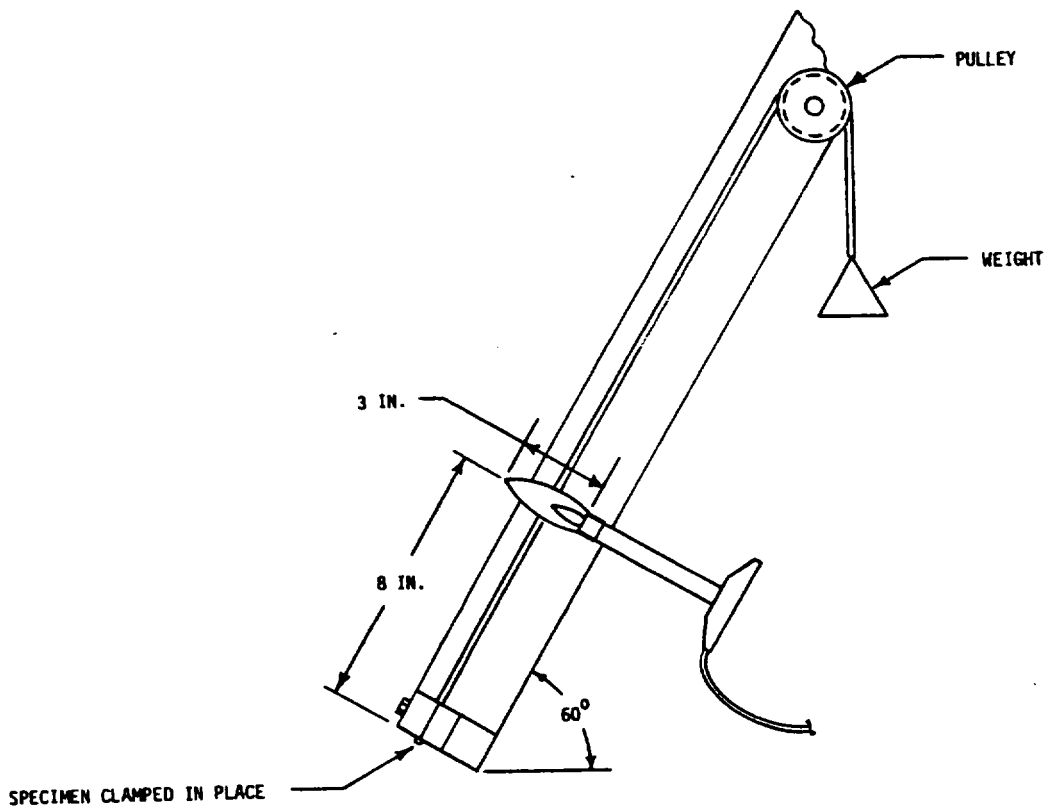

FLAMMABILITY TEST APPARATUS

FIGURE 29

7.1.14

FLEXURE ENDURANCE

A minimum of three samples of AWG 20 wire shall be suitably clamped in a fixture as in Figure 30. Using the mandrel size and weight in Table XIV below, rotate the wire through a 180 degree arc at a uniform rate of 18 ± 2 cycles per minute. A cycle shall include movement from the vertical to 90 degrees left then to 90 degrees right, and return to the vertical. The conductors shall be electrically connected in any suitable manner to determine conductor breakage.

TABLE XIV
FLEXURE ENDURANCE

WIRE SIZE	WIRE TYPE	MANDREL DIAMETER INCHES	WEIGHT POUNDS	MANDREL SPACING INCHES
20	VIII	.5	2.0	.070
20	XVI	.5	2.0	.080
20	XIX & XXII	.5	2.5	.080
20	XII	10X OUTSIDE DIAMETER OF CABLE SPECIMEN	3.0	SPECIMEN DIAMETER + 10 MILS

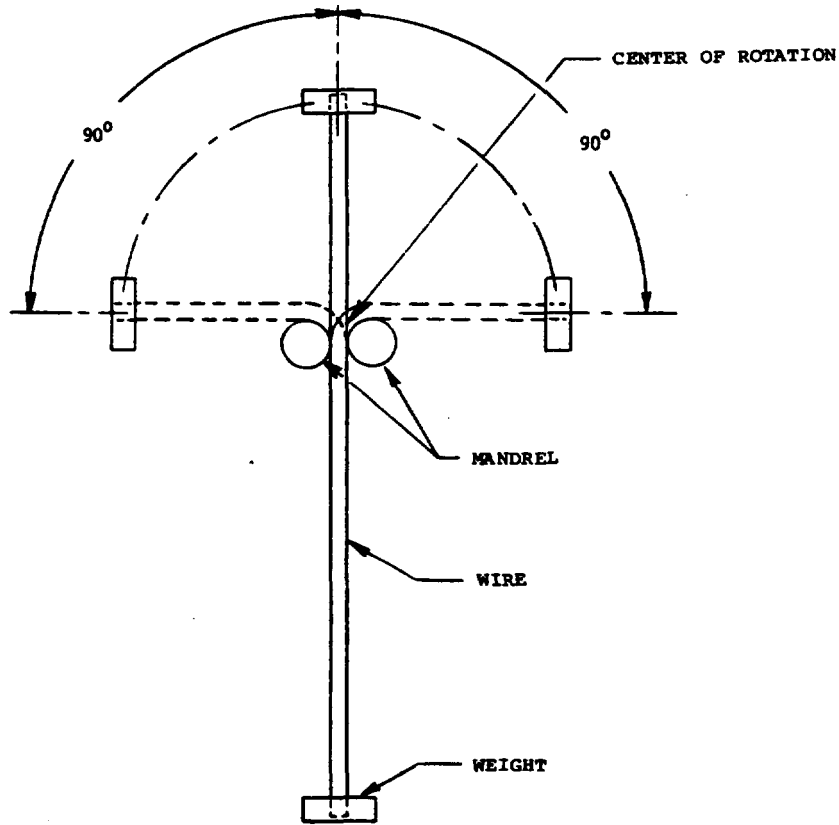

FLEXURE TEST FIXTURE

FIGURE 30

7.1.15 HUMIDITY RESISTANCE

7.1.15.1 Apparatus

The apparatus shall consist of a test chamber capable of maintaining an internal temperature of $71 \pm 2\text{C}$ and an internal relative humidity of 95 ± 5 percent. The test chamber shall be capable of being sealed so as to retain the total moisture content in the test space. The heat loss from the chamber shall be sufficient to reduce the internal temperature from the above specified operating temperature to not more than 38C within a period of 16 hours from the time of removal of the source of heat. Distilled or demineralized water shall be used to obtain the required humidity.

7.1.15.2 Procedure

A 52 foot specimen of wire shall be subject to the following:

The specimen shall be placed in the test chamber and the temperature and relative humidity raised to the values specified in Section 7.1.15.1. This condition shall be maintained for a period of six hours. At the end of the six hours, the heat shall be shut off. During the following 16 hour period the temperature must drop to 38C or lower. At the end of the 16 hour cooling period, heat shall again be supplied for two hours to stabilize to $71 \pm 2\text{C}$. This cycle shall be repeated to extend the total time of the test to 360 hours (15 cycles). At the end of the 15th cycle, the 50 foot center section of the specimen shall be immersed in a 5 percent saline solution at room temperature. The Insulation Resistance of the specimen shall be measured with the outer surface of the specimen grounded through an electrode in the electrolyte. Measurements shall be made after one minute of electrification with a potential of 250 to 500 volts dc applied to the conductor of the specimen.

7.1.16 IMMERSION

Fifty-five foot lengths of AWG 8 and 1/0, and 90 feet of AWG 20 and 14 shall be used for the test. AWG 20 and 14 shall be hot stamped in accordance with Section 7.2.3. The lengths shall be cut into 6 and 10 foot lengths as indicated in Table XV for individual immersion specimens. Two measurements, 90 degrees to each other, shall be taken at each of five random points which are located along the length of the sample, and not closer than six inches to either end. The average of the ten readings shall be considered the outside diameter.

The specimens shall be coiled over mandrels of the size specified in Table XV, removed from the mandrel as a coil, and the free ends tucked through the center to maintain the coil shape during the test.

The specimen shall be immersed to within six inches of the ends in each of the test fluids of Table XVI, using separate specimens for each fluid. The immersion time and temperature shall be as indicated for each test fluid.

After the immersion cycle, the specimens shall be removed from the test fluids, uncoiled, and wiped dry with a clean, lint-free cloth. The dimensional measurements shall be repeated in the same manner as above, and compared to the original diameters.

The six foot length of each sample shall then be subjected to two complete reverse bends around the mandrels of Table X, and to the Wet Dielectric test of Section 7.1.11, within one hour after removal from immersion. The remaining four foot lengths of the No. 20 and 14 AWG specimens shall be subjected to the Abrasion test of Section 7.1.22.

TABLE XV
IMMERSION TEST

TYPE	CLASS	SIZE AWG	MANDREL DIAMETER INCHES	SPECIMEN LENGTH FT.	ABRASION RESISTANCE
VIII	1	20	1.25	10	X
VIII	1	14	2.00	10	X
VIII	1	8	5.00	6	NA
VIII	1	1/0	11.00	6	NA

TABLE XVI
IMMERSION TEST FLUIDS

TEST FLUID	TEST FLUID TEMPERATURES	IMMERSION HOURS
Hydr. Fluid Type IV in accordance with BMS 3-11	70 ± 2C	24
Isopropyl, Alcohol, TT-I-735	23 ± 3C	24
Methyl Ethyl Ketone, TT-M-261	23 ± 3C	24
Anti-Icing Fluid 1	23 ± 3C	24
Lubricating Oil, MIL-L-23699	70 ± 2C	24
Lubricating Oil, MIL-L-7808	70 ± 2C	24
Alkaline Detergent (pH 10.0-10.5)	70 ± 2C	24
Fuel JP-4, MIL-T-5624	23 ± 3C	24
Hdr. Fluid, MIL-R-5606	70 ± 2C	24

1 Anti-icing fluid composition, percent minimum by weight

66.0 ethylene glycol MIL-E-9500, Grade A
 22.0 propylene glycol MIL-P-83800, Industrial grade
 10.0 water
 .90 dibasic potassium phosphate
 .65 sodium di-(2-ethylhexyl) sulfosuccinate (100 percent active)
 .45 benzotriazole

7.1.17

INSULATION ELONGATION AND TENSILE STRENGTH

Specimens of the entire insulation shall be carefully removed as a tube from the conductor and tested for tensile strength and elongation in accordance with FED-STD-228, Methods 3021 and 3031, using one-inch gauge marks and a one-inch initial jaw separation. Jaw separation speed shall be 20 inches per minute. For cable jackets, the method shall be the same, but only the cable jacket shall be tested.

7.1.18

INSULATION RESISTANCE

The uninsulated ends of a wire specimen at least 26 feet in length shall be connected to a DC terminal, and immersed to within 6 inches of its ends in a 5 percent salt solution at room temperature (23 ± 3C). The specimen shall remain immersed for not less than 4 hours, after which a voltage of 250 to 500 volts shall be applied between the conductor, and the water bath which serves as the other DC terminal. The insulation resistance shall be determined after one minute of electrification at this voltage, and shall be expressed as megohms/1000 feet by the following calculation:

$$\text{Megohms/1000 feet} = \frac{\text{Total specimen resistance (megohms)} \times \text{immersed length (feet)}}{1000}$$

7.1.19

INSULATION SHRINKAGE OR ELONGATION AND DELAMINATION

A 12 inch specimen of the finished wire shall be cut so that the insulation and conductor are flush at both ends. The specimen shall then be aged at 200 ± 3C for 6 hours in an air circulating oven with the insulation unrestricted. At the end of this period, the specimen shall be removed from the oven and allowed to cool to room temperature. The specimen shall then be examined to determine if any shrinkage or elongation of the insulation occurred. Any such shrinkage or elongation which occurred shall be measured to within .001 inch.

7.1.20

NOTCH SENSITIVITY

One inch of the insulation shall be removed from each end of five 24-inch specimens of finished, Type VIII, Class 1, AWG 20, 14, 8 and 1/0 wire. At the approximate center of each specimen the insulation shall be notched (cut) to a depth of .004 inches. The notch shall be made with a commercial grade stainless steel razor blade mounted in a suitable guide to control the depth of the notch. The specimens shall then be wrapped 360 degrees around a mandrel three times the outside diameter of the wire with the notch on the outside of the bend. The specimen shall then be removed from the mandrel and subjected to the Wet Dielectric test described in Section 7.1.11.

7.1.21

POLYIMIDE CURE

If a polyimide topcoat is used as a part of the insulation system the following test shall be conducted: Two hundred milliliters of distilled water together with a few boiling chips or beads shall be placed in a one liter erlenmeyer flask and the flask shall be closed by a rubber stopper fitted with a water cooled reflux condenser. The flask shall be heated by a hot plate or heating mantle until the water is boiling and condensate is returning from the reflux condenser. One end of an approximately 12 inch length of the wire to be tested shall be inserted into the flask by passing it between the rubber stopper and the side of the flask, or through a snugly fitting hole in the stopper, so that five inches of the wire length extends into the vapor phase inside the flask. The portion of the wire inside the flask shall be essentially straight and shall not be in contact with the glass sides of the flask or condenser, the layer of liquid water in the bottom of the flask, or the liquid condensate returning from the condenser. Heating of the flask shall be resumed, with the stopper and reflux condenser again in place. The portion of wire inside the flask shall be exposed to the vapor phase above the boiling water for exactly one hour and shall then be removed from the flask. A four inch specimen shall be cut from the vapor-exposed portion of the wire, avoiding the one inch which was nearest the rubber stopper during vapor exposure. The four inch specimen shall be allowed to cool at room temperature for a minimum of 15 minutes, after which it shall be wrapped in a tight spiral for six turns or the full length of the specimen, whichever is lesser, around a mandrel which for wire sizes 18 and smaller shall be equal to the maximum diameter of the wire, and for wire sizes 16 and larger shall be three times the maximum diameter of the wire. The specimen shall then be inspected visually for cracks without the aid of magnification.

7.1.22

SCRAPE ABRASION RESISTANCE

7.1.22.1

Apparatus

The scrape abrasion tester shall consist of a device which abrades the surface of the wire insulation by means of a weighted scraping fixture. The scraping action shall be in both directions along the longitudinal axis of the wire at a speed of 30 cycles per minute. The length of the scrape shall be two inches. The scraping device that contacts the wire surface shall be a Tungsten Carbide blade as shown in Figure 31. The test specimen shall be held taut and straight by clamps on a supporting anvil. The device shall be equipped with an electrical circuit designed to stop the machine when the scraping abrades through the insulation and contacts the conductor.

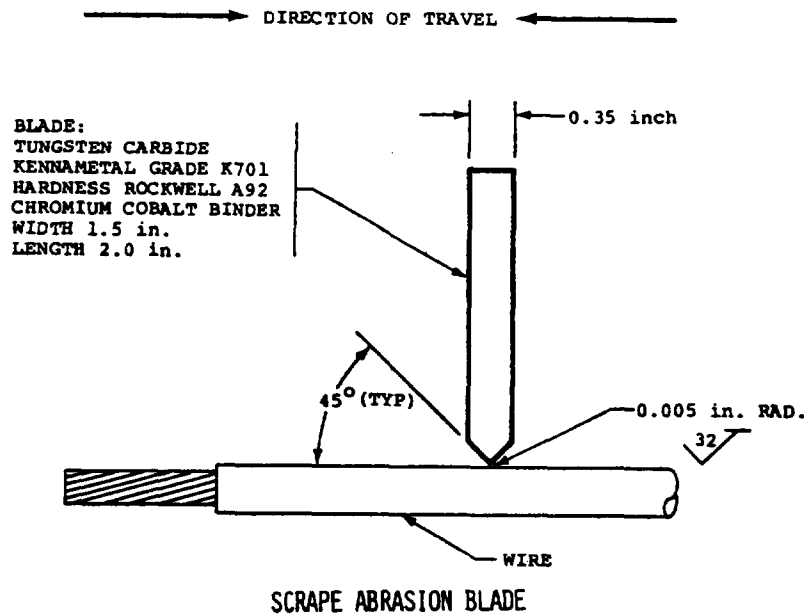

FIGURE 31

7.1.22.2

Procedure

One inch of insulation shall be removed from one end of each type of three 36 inch samples of the finished wire size listed in Table XVII. The test specimen shall be clamped in the tester and subjected to the abrasion test using the weight specified in Table XVII. Four tests shall be performed on each specimen with the specimen being moved forward four inches and rotated 90 degrees between each test. Scrape abrasion resistance shall be the number of cycles required for the scraping blade to abrade through the wire insulation and stop the machine. Tests shall be conducted at room temperature ($23 \pm 3C$).

TABLE XVII
SCRAPE ABRASION

WIRE SIZE AWG	WIRE TYPE	WEIGHT POUNDS
24	V	0.5
20	VIII	3.0
14	VIII	3.0
8	VIII	6.0
1/0	VIII	10.0
20	XVI	3.0
14	XVI	3.0

7.1.23

SHIELD COVERAGE

Shield braid coverage shall be determined by the following formula:

$$K = (2F - P^2) \times 100 = \text{Percent Shield Coverage}$$

Where:

K = Percent Coverage

$$F = \frac{NPd}{5 \sin a}$$

P = Picks per inch of cable length

a = Angle of braid with axis of cable

N = Number of strands per carrier

d = Diameter of individual shield strand, inches

$$\tan a = \frac{2 \pi (D + 2d) P}{C}$$

C = Number of carriers

D = Diameter of cable under braid, inches 1

1 For multi-conductor cable

$$D = \frac{(\pi + n) b}{\pi}$$

b = Diameter of basic wire

n = Number of basic wires

7.1.24

SMOKE TEST

7.1.24.1

Horizontal - Current Heating Test

This test shall be conducted in still air at an ambient temperature of $23 \pm 3\text{C}$. A 15 foot long wire specimen shall be suspended so that at least the central 10 foot section is horizontal and unsupported. One end of the wire shall be suitable weighted in order that no sagging will occur throughout the test. An electric current shall be applied to the wire, and the voltage drop measured over the central 10 foot portion. From the current and voltage values, calculate the resistance of the wire. The temperature of the wire conductor shall be determined from the change in resistance. The current shall be adjusted so that the conductor temperature stabilizes at $200 \pm 5\text{C}$ and shall be thus maintained for 15 minutes. A flat-black background shall be used for this test.

$$\frac{E}{I} = R_a \left[1 + \frac{T - t_a}{K + t_a} \right]$$

Where:

E = Measured voltage drop over the central 10-foot section of the specimen (volts)

I = Measured current (amps)

t_a = Measured room ambient temperature (degrees celsius)

R_a = Measured resistance of central 10-foot section of the specimen at temperature t_a (ohms)

T = 200C

$\frac{E}{I}$ = Calculated resistance of the central 10-foot section of specimen at temperature T (ohms)

K = Temperature coefficient of resistance factor for conductor material (degrees celsius)
 234.5 for tin-coated copper and nickel-coated copper,
 279.0 for silver-plated high-strength copper alloy.

7.1.24.2

NBS Chamber Test

A ten foot length of AWG 20 shall be wrapped on a frame, placed into a holder, backed with a foil covered asbestos board, and installed in a test frame. The frame shall be placed into a National Bureau of Standards (NBS) Smoke Test Chamber. Using a 2.5 W/Cm^2 heater and operating in the flaming mode, subject the specimen to a 4 minute test. Standard chamber operating procedures shall be used for all tests. Determine the smoke level by measuring the progressing attenuation of a light beam passed through the smoke within the chamber. Repeat the test using a total of four 10 foot long specimens.

7.1.25

SURFACE RESISTANCE

7.1.25.1

Specimens

The specimens shall consist of six inch lengths of finished wire, cleaned in accordance with the procedure for Group I materials in ASTM D 1371. The specimens shall subsequently be handled with maximum care, preferably with clean lint free gloves to avoid contamination. Each cleaned specimen shall be provided, near its center, with two electrodes spaced 1.0 ± 0.05 inch apart between their nearest edges. Each electrode shall be approximately $1/2$ inch wide and shall consist of conductive silver paint (DuPont 4817 or equivalent) painted around the circumference of the specimen. Electrical connection to the dry electrodes may be made by wrapping several turns of fine (AWG size 28 or finer) tin-coated copper wire around the electrode, leaving a free end of the fine wire of sufficient length for soldering to the electrical lead wires.

7.1.25.2

Test Chamber

The test chamber shall be a Blue M Company, Model FR-1000A or equivalent as shown in Figure 32. Ambient conditions for this test shall be a relative humidity of 95 ± 5 percent and a temperature of 23 ± 3C. The test chamber shown in Figure 32 is a tightly covered rectangular glass vessel containing a reservoir of aqueous solution to maintain the required relative humidity (See ASTM E 104, Method C) and a humidity gauge, when applicable, observable from outside the chamber, to indicate the relative humidity actually obtained. On the two long sides of the vessel, tin-coated AWG size 18 solid copper lead wires penetrate and are permanently sealed into the paraffin wax collar shown in Figure 32, at intervals of approximately one inch and at least one inch from any edge. As an alternate, the leads may be insulated with polytetrafluoroethylene (PTFE) and brought outside of the chamber through paraffin wax, silicone stopcock grease, or PTFE bushings, provided at least two inches of PTFE insulation extends beyond the seal inside the chamber. The chamber cover is lubricated with silicone stopcock grease to minimize interchange of air. The electrical resistance of the chamber, measured across the lead wires under the specified test conditions of relative humidity and temperature, but with no specimens in place, shall be a minimum of one million megohms.

7.1.25.3

Procedure

With the specimens and electrodes prepared as specified in Section 7.1.25.1, the electrodes shall be connected to the lead wires in the test chamber. In all cases, the wire specimens shall be installed so that their ends are a minimum of one inch from the walls of the chamber. The cover of the chamber shall be put in place, and the test assemblies shall be conditioned for 96 hours at the relative humidity and temperature specified in Section 7.1.25.2. The resistance between the electrodes shall then be measured in the test chamber after a one-minute electrication. The surface resistance value shall be computed by multiplying the measured resistance value by the measured overall diameter of the specimen in inches. Following the initial resistance measurement, 2500 volts rms shall be applied between the electrodes for a period of one minute. There shall be no evidence of distress such as arcing, smoking, burning, flashover, dielectric failure. After a discharge interval of 15 to 20 minutes following the voltage test, the surface resistance shall be measured and computed. Both values of computed surface resistance shall be greater than the minimum specified in Section 4.5.1.23.

7.1.26

TAPE ABRASION RESISTANCE

The apparatus for performing this test shall consist of an abrasion tester constructed in accordance with specification MIL-T-5438. The abrasant shall be a 400 Grit Aluminum Oxide tape. Stripes of silver conductive paint, 1/4 inch wide, spaced three inches center to center, shall be used. The silver conductive paint shall be duPont 4817 or equivalent. A 36 inch sample of the wire or cable shall be placed in the tester. Wire or cable size 26 through 10 shall be held taut by clamping one end and applying a tension load weight on the other end. Wire or cable size 8 thru 1/0 shall be held taut by clamping both ends. The detection circuit leads shall be applied between the wire conductor and the detector roller. Using the tension load, weight support brackets, and weight specified in Table XVIII, subject the sample to the abrasion test. At the start of each test the center of the conducting stripe shall be at the point of contact with the wire. After each reading, the specimen shall be moved forward two inches and rotated 90 degrees. Eight tests shall be performed for each sample. An average of the readings shall be obtained by calculating the arithmetic mean of all readings which are individually less than the arithmetic mean of all eight readings. This average shall define the abrasion resistance of the wire or the cable jacket as applicable.

TABLE XVIII
TAPE ABRASION

WIRE SIZE AWG	TYPE	WEIGHT SUPPORT BRACKET	WEIGHT POUNDS	TENSION LOAD POUNDS
24	V	A	1.0	1.0
20	VIII	A	1.0	1.0
14	VIII	B	2.0	2.0
8	VIII	B	3.0	---
1/0	VIII	C	4.25	---
20	XVI	A	1.0	1.0
14	XVI	B	2.0	2.0

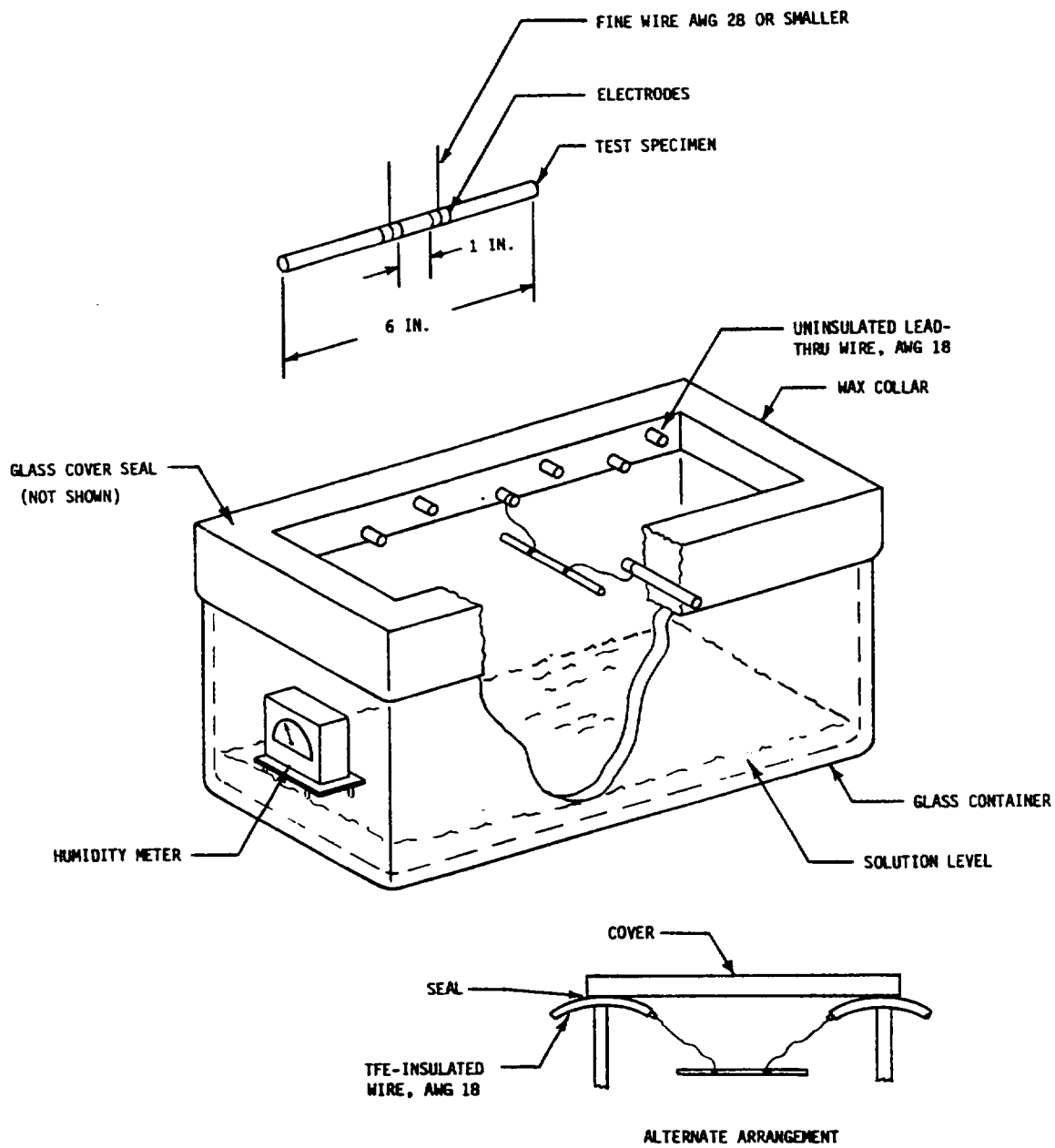

TYPICAL SURFACE-RESISTANCE TEST CHAMBER

FIGURE 32

7.1.27 THERMAL SHOCK RESISTANCE

7.1.27.1 Preparation of Specimen

A specimen of wire, five feet long, shall be prepared by carefully removing one inch of insulation from each end of the wire. A razor blade or equivalent, held perpendicular to the axis of the wire, shall be used to cut the insulation for the removal operation. The length of exposed conductor at each end of the specimen shall be measured to the nearest 0.01 inch. The specimen shall then be laid on a wire screen for handling throughout the test.

7.1.27.2 Test Procedure

The specimen shall be conditioned for 30 minutes in a preheated air circulating oven at the temperature $200 \pm 2C$. The specimen shall then be removed from the oven and, within two minutes, placed in a chamber which has been precooled to $-65 \pm 2C$. It shall be exposed to this temperature for 30 minutes, after which it shall be removed and allowed a minimum of 30 minutes to return to room temperature (20 to $25C$). At the conclusion of this cycle, the distance from the end of each layer of insulation to the end of the conductor shall be measured to the nearest 0.01 inch. This thermal shock cycle and the measurements shall be repeated for an additional three cycles (a total of four cycles). Any measurement varying from the original measurement by more than the amount specified in Section 4.5.1.25 shall constitute failure. Flaring of any layer shall also constitute failure.

7.1.28 WIRE WEIGHT

The weight of each lot of finished wire or cable shall be determined by Procedure I. Lots failing to meet the wire weight requirements of Figure 1 through 24, when tested in accordance with Procedure I, shall be subjected to Procedure II. All wire lots failing to meet the requirement of both procedures shall be rejected.

7.1.28.1 Procedure I

Three specimens at least 10 feet long shall be selected at random from each lot of finished wire. The length and weight of the specimens shall be accurately measured with the resultant measurements transposed to pounds per 1000 feet. The average weight for the wire lot shall be determined from these values.

7.1.28.2 Procedure II

Three reels of the inspection lot shall be selected for checking. The net weight of the finished wire on each reel or spool shall be obtained by subtracting the tare weight of the reel or spool from the gross weight of the reel or spool, dividing the difference by the accurately determined length of finished wire on that reel or spool, and transposing the resultant to pounds per 1000 feet. When wood or other moisture absorbant materials are used for reel or spool construction, weight determinations shall be made under substantially the same conditions of relative humidity.

7.1.29 WICKING

A specimen of each finished wire size to be tested shall be cut $6 \pm 1/16$ inch with square ends. The specimen shall be vertically immersed for two inches of its length in Esterlin Angus, Medium Dry, Red Instrument Ink, which is contained in an open test tube, and conditioned for 24 hours at room temperature in a draft-free room. After this conditioning, the ink on the surface shall be removed immediately from the two inches immersed by wiping gently with a clean, dry, lint-free cloth. The specimen shall then be examined for wicking between insulation layers. The distance that the ink has wicked above the two inch immersed portion of the specimen shall be recorded as the distance of wicking.

7.1.30 WIRE TO WIRE ABRASION TEST

Specimens of Type VIII and Type XVI, Class 1, AWG 20 wire shall be mounted in a test jig as shown in Figure 33. The moveable member of the fixture shall be activated by a vibration tester exciter or other suitable device. The activating device shall be adjusted to produce a sinusoidal mode at 10 cycles/second and a displacement of 0.25 inch double amplitude. The tension shall be applied by attaching a 1, 2.5, or 5 pound mass to the free end of the wire. A minimum of three test samples will be used for each mass. An electrical detector shall be installed to indicate when both conductors are exposed.

This test is required of all candidate wire against all other candidate or qualified wire. If any wire is unacceptable when tested against other products, but is acceptable when tested against itself, it must be noted on the QPL.

7.1.30

(Continued)

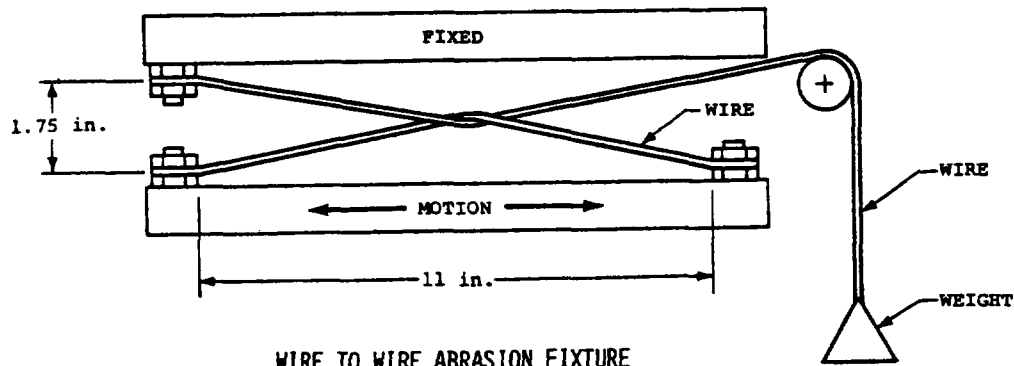

WIRE TO WIRE ABRASION FIXTURE

FIGURE 33

7.1.31

WRAP TEST

Wire specimens shall have a length of 24 inches plus a length required for winding tightly around itself or around a mandrel as specified below. A total of four close turns of a central portion of the specimen shall be made such that six inches of each end shall remain straight. Wrapping is to be accomplished manually. Wire size 2 through 1/0 shall be wrapped around a 10 X mandrel. Wire size 8 through 4 shall be wrapped around a mandrel six times the diameter of the wire. The specimens shall be conditioned in an air circulating oven at 250 + 3C for 7 hours, then removed, visually examined, and subjected to the Wet Dielectric Test of Section 7.1.11.

7.2

HANDLING, ASSEMBLY, AND INSTALLATION

7.2.1

FLEXIBILITY

An 18 inch long specimen shall be mounted in the tester as shown in Figure 34 with standard tester mandrel accessories. The specimen shall be rotated clockwise at a uniform rate of approximately 20 degrees per second, to the 90 degree position. The torque indicator value shall be recorded. Wire travel shall be continued to the 180 degree position. The torque indicator value shall again be recorded. After one minute in this position, the wire shall be released of tension. After 10 seconds the angle of wire return from the 180 degree position shall be measured and recorded as the spring-back.

MANDREL SIZES

WIRE SIZE	WIRE TYPE	WIRE CLASS	MANDREL DIAMETER
24	V	1	.187
20	VIII	1	.187
14	VIII	1	.421
8	VIII	1	1.500
1/0	VIII	1	1.500
20	XVI	1	.312
14	XVI	1	.421

7.2.1

(Continued)

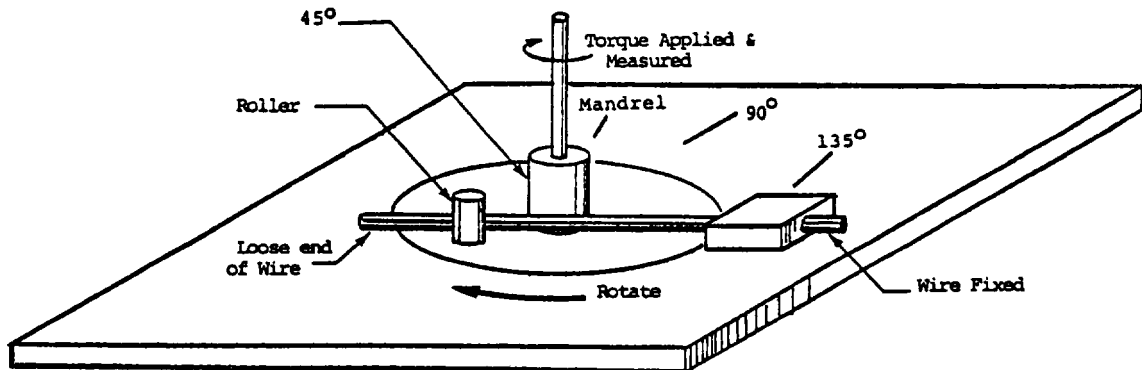

WIRE FLEXIBILITY TESTER

FIGURE 34

7.2.2

DURABILITY OF PRODUCT IDENTIFICATION

The durability of product identification, color, and color striping applied to the wire for coding shall be evaluated at $23 \pm 3C$ as follows:

a. Testing Apparatus

The markings durability tester shall be designed to hold a short specimen of finished wire firmly clamped in a horizontal position with the upper longitudinal surface of the specimen fully exposed. The instrument shall be capable of rubbing a small cylindrical steel mandrel (usually a needle), 0.025 inch in diameter maximum, repeatedly over the upper surface of the wire, in such position that the longitudinal axis of the mandrel and the specimen are at right angles to each other, with the cylindrical surfaces in contact. A weight affixed to a jig above the mandrel shall control the thrust normal to the surface of the insulation. A motor driven, reciprocating cam mechanism, and counter shall be used to deliver an accurate number of abrading stroke in a direction parallel to the axis of the specimen. The length of the stroke shall be $3/8$ inches, and frequency of the stroke shall be 30 cycles per minute.

b. Testing Procedure.

In performing the test, a specimen of wire shall be mounted in the specimen clamp and the weight of 500 grams for wires without an outer braid, and 150 grams for wires with an outer braid, shall be applied through the abrading mandrel to the marked surface. The counter shall be at zero, and the drive motor started. The specimen shall be observed throughout the progress of the test and as soon as a continuous line of the solid color insulation, or coating, or of the stripe, band, or printed marking is removed under the abrading mandrel, the number of abrading cycles shall be recorded. Unless otherwise specified, three specimens from each sample unit shall be tested and the results averaged.

7.2.3

MARKABILITY

7.2.3.1

Hot Stamp

7.2.3.1.1

Marking Process

Specimens shall be tested for markability in the as-received condition. A 100 foot specimen selected at random shall be marked using normal handling procedures. A Conrac (or equivalent) hot embossing single step process machine shall be used to imprint the specimen with the characters one through five and the letters A through D, indenting the wire to 0.0015 inch maximum. No post cure for the marking is allowed. The marking foil shall be Kingsley No. K-496 color purple, and shall be applied to the specimen using a temperature, pressure, and dwell time adjusted to obtain the best pigment transfer, and the best marking permanence. The adjusted temperature shall be within the limits of $180 \pm 20C$.

7.2.3.1.2 Test

After a cooling or setting time of at least two minutes, the marked wire or cable shall be mounted in the specimen clamp of a General Electric Repeated Scrape Abrasion Tester, Type 512040G1 (Modified), or equivalent, so that the rubbing member will contact the marking. A weight, including the weight of the fixture, of two pounds shall be applied through the rubbing member to the identification marking. The rubbing member shall be a 3/16-inch-wide micarta block with 1/32-inch corner radii, covered with 1/16-inch-thick felt in accordance with Federal Specification C-P-206B Type I, Classification 984 (American Felt Company number 133). The speed of the reciprocating abrading head shall be 60 cycles per minute maximum.

Six separate marks on each specimen shall be tested. The test shall be terminated after 30 rubs (15 cycles), or after failure, whichever occurs first. The specimen is considered to have failed when any portion of any character is completely rubbed through. The values obtained for the six tests shall then be averaged. This average shall be listed as the test result. Following the Rub test, a Wet Dielectric test shall be performed in accordance with Section 7.1.11.

7.2.3.2 Ink Jet

7.2.3.2.1 Marking Process

A 100-foot specimen shall be marked with the ink jet (deposited) process, in the as-received condition, using normal handling procedures. Circuitry coding shall be designated with G10LS ink manufactured by American Can Company and applied with an American Can Company IJWM 9400 series, or equivalent, ink jet marking machine.

7.2.3.2.2 Test

Following a 24-hour setting time, specimens of marked wire shall be subjected to a rub test per 7.2.3.1.2 except that a one pound weight shall be used. A separate piece of the ink jet marked sample shall be subjected to the following light fastness test. Place the specimen in a Weatherometer tester and cycle for 102 minutes of ultraviolet light followed by 18 minutes of ultraviolet light plus a tap water spray. Repeat this cycle five additional times, for a total of six cycles (12 hours).

7.2.4 INSULATION REMOVAL

Adjust a carpenter single blade rotary stripper to acceptably strip 10 consecutive samples of Type I, Class 1, AWG 24, Type VIII, Class 1, AWG 20 and 14 wire, and Type XVI, Class 1, AWG 20 and 14 wire (without scraping the conductor).

The stripper shall be mounted on the stationary member of an Instron Tensile Tester (or equivalent) as shown in Figure 35. Attach the test specimen to the movable head of the tensile tester, and with the stripper turned off, insert the loose end into the stripper to a depth suitable to remove a $.25 \pm .05$ inch slug of insulation. Turn the stripper on and allow it to run a minimum of 30 seconds. Operate the tensile tester at a speed of 50 inches per minute, and record the tensile force required to remove the insulation slug while the stripper is running.

Repeat this procedure on the opposite end of each test sample after cutting off any portion of the wire that was gripped by the tensile tester.

7.3 PRODUCT CONTROL

7.3.1 JACKET FLAW

Procedure I (Spark Test)

The flaw test of the jacket shall be conducted as described in FED-STD-228, Method 6211, with the shield being used as a conductor.

Electrode length, and speed of cable through the electrode shall be such that all surface area of the jacket will be subjected to a voltage of 1.0 Kv to 1.5 Kv for a minimum of 0.20 seconds.

Procedure II (HV Impulse Test)

One hundred percent of the finished cable shall be tested in accordance with Section 7.1.9.

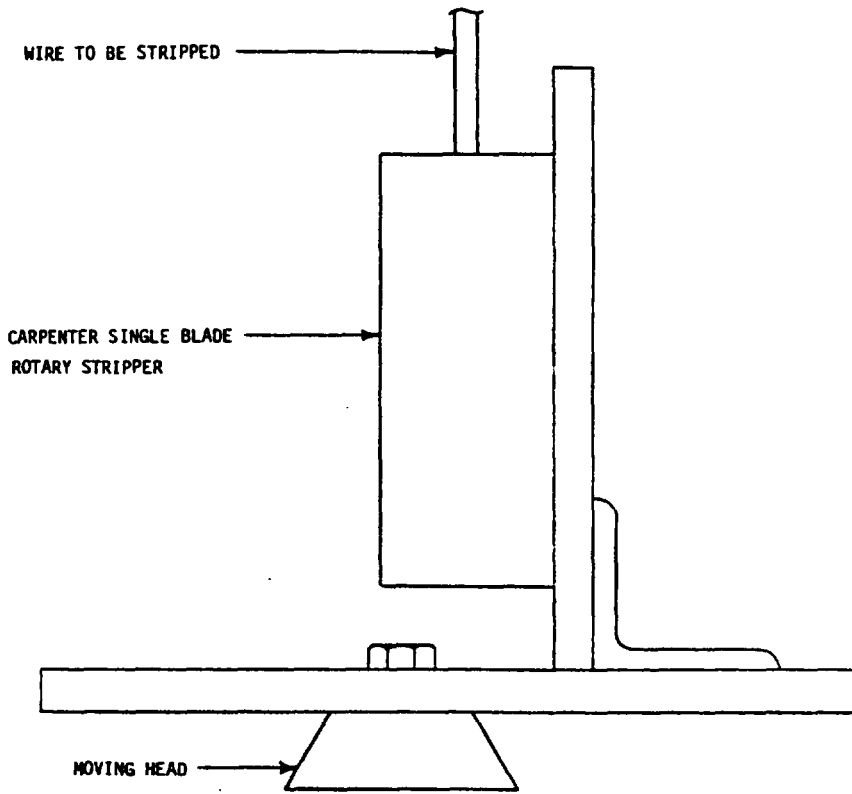
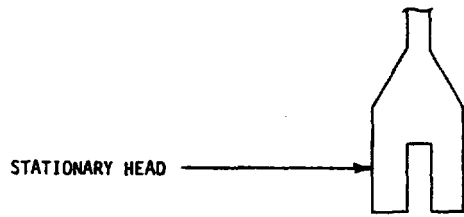

INSULATION REMOVAL TESTER

FIGURE 35

7.3.2

WORKMANSHIP

All details of workmanship shall be in accordance with high-grade wire and cable manufacturing practices. Manufacturing processes shall be used to ensure the consistent compliance with the requirements of this specification when tested in accordance with Section 7. In addition, the finished product shall comply with the requirements of Section 4.5.3.2.

7.3.3

VISUAL AND DIMENSIONAL

In addition to all other tests, the finished wire or cable shall be inspected to ensure that finished products conform to the general physical characteristics defined in this specification. The following list of items is the minimum requiring examination during V&D inspection. The requirements for a particular suppliers finished wire and cable are contained in the QSS drawing corresponding to the Qualified Supplier Sheet number contained in the wire part number (See Section 8.1 and 8.2).

a. Conductor

- (1) Diameter
- (2) Number of Strands
- (3) Strand Coating
- (4) Type of Stranding
- (5) Diameter of Strands

b. Finished Wire or Cable

- (1) Maximum diameter of finished wire or cable.
- (2) Construction of finished wire or cable to conform to Type and Class designation.
- (3) Color-code identification for individual wires of a multi-conductor cable applied as specified.
- (4) Continuity, uniform application of insulations and jackets on wire or cable.
 - (a) Variations in color which do not exceed the light-dark limits established by MIL-STD-104, or this specification are acceptable.
 - (b) Discolorations due to foreign materials are not acceptable, i.e.,
 - 1) Overheated or scorched insulations or jackets
 - 2) Dust, grease or oil contamination
 - (c) Voids or delaminations in the insulation or jacket which can be detected without magnification insulation or in tightly fitting jackets that do not increase the diameter in excess of the computed maximum outside diameter, are acceptable.
 - (e) Metallic or gritty particles in the insulation or jacket, are not acceptable.
- (5) Thickness of wire or cable jacket where applicable.
- (6) Push-back characteristics for shield on Type III, VI, XII, XIII, XV, XVIII, XXI, and XXIV cable.
- (7) Tendency of Class 2 or greater cable to untwist when cut as a unit.
- (8) Blocking of adjacent conductors in multi-conductor cable.

8.

IDENTIFICATION

8.1

ALL TYPES, CLASS 1

All Types, Class 1 wire or cable shall be identified by permanent printed marking applied at regular intervals to the outer surface of the finished wire or component wire as applicable. As an option, the identification may be applied to the cable jacket rather than the component wire. Spacing between the last and the first letter of adjacent marking shall be six inches (nominal).

8.1 (Cont'd)

The printed identification shall consist of the following:

- a. Wire Specification and QPL Qualified Supplier Sheet (QSS) Number
- b. Wire Type
- c. Wire Class
- d. Wire Size
- e. Manufacturer's code number or trade mark.

Example: W48C/01 1/1-20 XXXXX

Indicates: BMS 13-48C/XX, Type I, Class 1, Size 20,

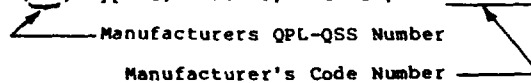

8.2 ALL TYPES, CLASS 2 THROUGH 24

For Class 2 through 24 cable the identification shall be only on the red component wire. As an option, the identification may be applied to the cable jacket rather than the component wire.

The cable identification shall be imprinted at intervals of not more than six inches and shall consist the following:

- a. Wire Specification and QPL-QSS Number
- b. Wire Type
- c. Wire Class
- d. Wire Size
- e. Manufacturer's code number or trade mark

Example: W48C/01 3/4-6 XXXXX

Indicates: BMS 13-48C/XX, Type III, Class 4, Size 6,

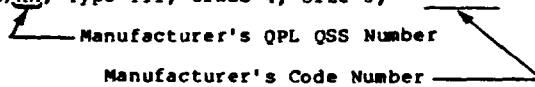

8.3 APPLICATION AND COLOR OF IDENTIFICATION MARKING

Unless otherwise specified on the purchase order, the following shall apply:

8.3.1 TYPES I THROUGH XXI

The identification marking on all wire and cable shall be permanent and of sufficient size to be intelligible. When the finished diameter is 0.054 inch or less, the marking shall be within the limits of MIL-STD-104, Class 1. The color of the marking on all wire with a marking surface color of red, blue, green, black, purple, or brown shall be white within the MIL-STD-104, Class 1, limits. The marking shall meet the requirements of Section 4.5.2.2

8.3.2 TYPES XXII THROUGH XXIV

The identification marking shall be in accordance with 8.3.1 except that the color of the marking on all wire and cable with a marking surface color of white, shall be orange, within the limits of MIL-STD-104, Class 1. In addition, a series of six 0.10 inch dashes shall be applied at the approximate mid-point between the identification markings. The dashes shall be a maximum of 0.06 inches wide, and shall be spaced 0.10 inches apart. The color of the dashes shall be the same as that of the identification marking.

Jacketed cable which has no identification marking on the jacket, shall have orange colored dashes applied along its length. The length of the dashes may vary from a minimum of .25 inch to a maximum of 1.0 inch. The width shall not exceed 0.06 inches. Spacing between the dashes is not critical.

Example:

W48C/01/1/1-20 XXXXX - - - - - W48C/01/1/1-20 XXXXX

9. PACKAGING AND MARKING

Unless otherwise specified on the purchase order, wire and cable shall be prepared for shipment according to the following requirements.

9.1 PACKING

9.1.1 Type I, V, VIII, IX, X, XI, XVI, XIX, XXII, and XXIII Wire and Cable

- a. The wire or cable of a given lot shall be wound on spools or reels, with a minimum barrel diameter 50 times the wire diameter for size 26 through 14, 40 times the wire diameter for size 12 through 10, 30 times the wire diameter for sizes 8 through 1/0, and 20 times the wire diameter for size 2/0 through 4/0. The minimum barrel diameter for any wire size shall be 3-1/2 inches with a hole size of 1-1/2 inches in diameter.
- b. The minimum acceptable finished lengths for Wire (Types I, V, VIII, IX, X, XI, XVI, XIX, XXII and XXIII Class 1) shall conform to Table XIX.
- c. One foot of each end of each continuous length of multiconductor wire or cable on each spool or reel shall be accessible for inspection tests. If the spool or reel contains more than one length of wire or cable, the ends of each length shall be marked or tagged for identification.

Acceptable shipping lengths of Class 1 wire sizes 26 through 10 AWG shall be wound on a reel or spool in one continuous length. The ends of different lengths of wire shall be telephone spliced together to form a continuous length and the insulation stripped from the conductor for at least six inches in each direction from the splice. The splice shall be finished off smooth and free of burrs and flagged with an international orange color tape to prevent damage to adjacent coils of wire as shown in Figure 36. The quality of the tape and adhesive shall be such that the tape flag shall remain intact during normal handling and shipping operations. Both ends of each continuous length of wire on a spool or reel shall be brought out on the inside of the flanges and shall be accessible above the surface of the wire for a minimum of 12 inches. The loose ends shall be taped to the inside of the flange. No adhesive shall be in contact with the wire surface, other than the fastened ends.

- d. The maximum number of splices, in any reel, spool, delivery lot, or shipment shall conform to the following formula:

$$S_{\max} = \frac{L_T}{L_{AV}}$$

Where:

S_{\max} = An integer representing the maximum allowable number of segments.

NOTE: S_{\max} should always be rounded off to the next highest integer.

L_T = Total length of wire being examined, i.e., may be a segment, reel, spool, delivery lot or shipment. The minimum acceptable length for any segment is contained in Table XIX. L_T must be determined for each particular Type, Class, and Size of wire or cable contained in a shipment.

L_{AV} = Average length per segment as described in Table XIX.

For values of L_T which are equal to or less than L_{AV} , the maximum permissible number of segments in any inspection lot shall be two.

The inspection lot to which this paragraph applies will be any lot from the same shipment on any single day.

- OPTIONS:
- 1. When specified on the individual purchase order, acceptable shipping lengths may be shipped on a single reel or spool without splicing. When this method is requested, at least 12 inches of each end of each length shall be accessible for inspection tests.
 - 2. The ends of different lengths of wire wound on a reel or spool may be butt welded rather than telephone spliced. If butt welding is used, the international orange tape flag shall be replaced by a tape wrap of the same color. The tape wrap shall be such that the total O.D. of the wrap does not exceed the insulation O.D. by more than 0.003 inches.

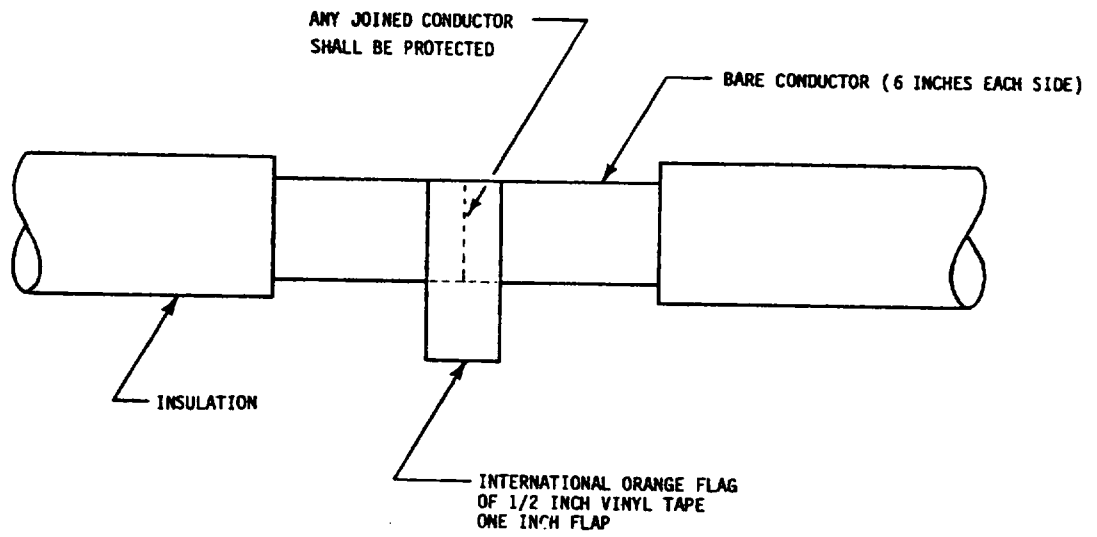

SPLICE IDENTIFICATION

FIGURE 36

9.1.1

(Continued)

TABLE XIX
TYPE I, V, VIII, IX, X, XI, XVI, XIX, XXII AND XXIII,
CLASS 1, WIRE - SHIPPING LENGTHS

WIRE GAUGE	MINIMUM ACCEPTABLE SEGMENT LENGTH (L_T)	L_{AV} (FT)
26 - 20	500	3155
18 - 14	500	2020
12 - 8	500	1020
6 - 4	300	520
2 - 4/0	100	275

9.1.2

Type I, III, IV, V, VI, VII, VIII, IX, X, XI, XII, XIII, XIV, XV, XVI, XVII, XVIII, XIX, XX, XXI, XXII, XXIII and XXIV Cable

Acceptable shipping lengths shall be specified on individual purchase orders. The cable shall be delivered on spools or reels having a minimum barrel diameter as specified in Section 9.1.1.a.

9.2

PACKAGING

Packaging shall insure that the electric wire will be adequately protected, during shipment and storage, both from physical damage and from the effects of harmful materials and environments.

9.3

MARKING

Each package and each reel or spool shall be durable and legibly marked to give the following information:

- a. Boeing Material Specification 13-48C, Manufacturers QPL-QSS Number, Type, Class, Size.
- b. Manufacturer's Part Number
- c. Total and Individual Wire or Cable Lengths in Feet
- d. Order of Individual Wire or Cable Lengths as put on Shipping Reel
- e. Actual Finished Wire Weight in Pounds
- f. Purchase Order Number
- g. Manufacturer's Name
- h. Date of Manufacture
- i. Manufacturer's Lot Number

NOTE: c., d., and e. may be eliminated on containers used for shipping reels or spools

TABLE XX
QUALIFICATION AND PURCHASER INSPECTION TESTS

TEST	REQUIREMENTS	TEST METHOD
Design and Performance	4.5.1	7.1
Accelerated Aging and Life Cycle	4.5.1.1	7.1.1
Blocking	4.5.1.2	7.1.2
Cold Bend	4.5.1.3	7.1.3
Concentricity	4.5.1.4	7.1.4
Conductor D.C. Resistance	4.5.1.5	7.1.5
Conductor Elongation and Tensile Strength	4.5.1.6	7.1.6
Current Overload	4.5.1.7	7.1.7
Deformation	4.5.1.8	7.1.8
Impulse Dielectric	4.5.1.9.1	7.1.9
Dry Dielectric	4.5.1.9.2	7.1.10
Wet Dielectric	4.5.1.9.3	7.1.11
Dynamic Cut-Through	4.5.1.10	7.1.12
Flammability	4.5.1.11	7.1.13
Flexure Endurance	4.5.1.12	7.1.14
Humidity Resistance	4.5.1.13	7.1.15
Immersion	4.5.1.14	7.1.16
Insulation Elongation and Tensile Strength	4.5.1.15	7.1.17
Insulation Resistance	4.5.1.16	7.1.18
Insulation Shrinkage or Elongation	4.5.1.17	7.1.19
Notch Sensitivity	4.5.1.18	7.1.20
Polyimide Cure	4.5.1.19	7.1.21
Scrape Abrasion Resistance	4.5.1.20	7.1.22
Shield Coverage	4.5.1.21	7.1.23
Smoke Tests	4.5.1.22	7.1.24
Surface Resistance	4.5.1.23	7.1.25
Tape Abrasion Resistance	4.5.1.24	7.1.26
Thermal Shock Resistance	4.5.1.25	7.1.27
Weight	4.5.1.26	7.1.28
Wicking	4.5.1.27	7.1.29
Wire to Wire Abrasion	4.5.1.28	7.1.30
Wrap Test	4.5.1.29	7.1.31
Handling and Installation	4.5.2	7.2
Flexibility	4.5.2.1	7.2.1
Durability of Product Identification	4.5.2.2	7.2.2
Markability	4.5.2.3	7.2.3

TABLE XX (Continued)

TEST	REQUIREMENTS	TEST METHOD
Insulation Removal	4.5.2.4	7.2.4
Product Control	4.5.3	7.3
Jacket Flaw	4.5.3.1	7.3.1
Workmanship	4.5.3.2	7.3.2
Visual and Dimensional Inspection	4.5.3.3	7.3.3
Color Code	4.1	----
Conductor	4.2	----
Insulation	4.3	----
Construction	4.4	----
Performance Requirements	4.5	7.
Identification of Product	8.	----

TABLE XXI

SUPPLIERS QUALITY CONFORMANCE INSPECTION TESTS

TEST	REQUIREMENTS	TEST METHOD
Concentricity	4.5.1.4	7.1.4
Conductor D.C. Resistance	4.5.1.5	7.1.5
Impulse Dielectric 1	4.5.1.9.1	7.1.9
Dry Dielectric 1	4.5.1.9.2	7.1.10
Flammability	4.5.1.11	7.1.13
Insulation Resistance	4.5.1.16	7.1.18
Insulation Shrinkage or Elongation	4.5.1.17	7.1.19
Polyimide Cure 2	4.5.1.19	7.1.21
Weight	4.5.1.26	7.1.28
Wrap Test	4.5.1.29	7.1.31
Durability of Product Identification	4.5.2.2	7.2.2
Markability (Ink Jet Only)	4.5.2.3	7.2.3
Jacket Flaw	4.5.3.1	7.3.1
Workmanship	4.5.3.2	7.3.2
Visual and Dimensional	4.5.3.3	7.3.3
Color Code	4.1	----
Conductor	4.2	----
Insulation	4.3	----
Construction	4.4	----
Identification of Product	8.	----

1 This test shall be performed on all wire, or cable (as applicable), of the Inspection Lot.

2 Applies only to products which employ a polyimide topcoat

APPENDIX II

MIL-W-81044/9

Wire Specification

MIL-W-81044 / 9(AS)

MILITARY SPECIFICATION SHEET

WIRE, ELECTRIC, CROSSLINKED POLYALKENE INSULATED, 30 March 1967
 TIN-COATED COPPER, MEDIUM WEIGHT, 150°C

The complete requirements for procuring the wire described herein shall consist of this document and the Issue in effect of Specification MIL-W-81044

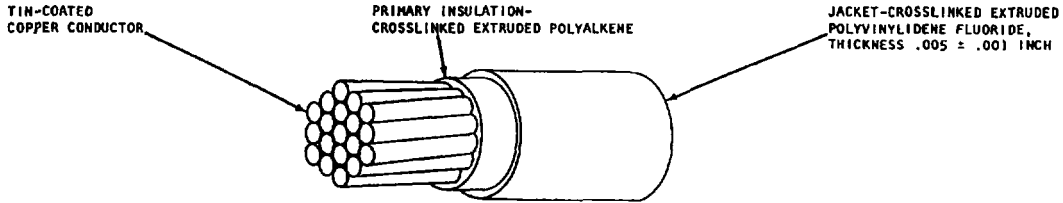

TABLE I. CONSTRUCTION DETAILS

DASH NO.	WIRE SIZE (AWG)	CONDUCTOR STRANDING (NO. x AWG)	MAXIMUM DIAMETER STRANDED CONDUCTOR (INCHES)	MAX. RESISTANCE AT 20°C (68°F) (OHMS PER 1000 FEET)	FINISHED WIRE		
					DIAMETER (INCHES)	NOMINAL WEIGHT (LBS/1000 FT)	MAXIMUM WEIGHT (LBS/1000 FT)
-24-w	24	19 x 36	.026	25.4	.054 ± .002	2.5	2.7
-22-w	22	19 x 34	.033	15.9	.062 ± .003	3.7	3.9
-20-w	20	19 x 32	.041	9.76	.070 ± .003	5.3	5.5
-18-w	18	19 x 30	.052	6.22	.080 ± .003	7.7	8.0
-16-w	16	19 x 29	.058	4.82	.089 ± .004	9.6	10.1
-14-w	14	19 x 27	.072	3.05	.108 ± .004	14.8	15.5
-12-w	12	37 x 28	.090	2.00	.126 ± .004	21.6	23.0
-10-w	10	37 x 26	.118	1.26	.155 ± .005	34.0	35.7
-8-w	8	133 x 29	.176	0.702	.214 ± .006	59.7	62.8
-6-w	6	133 x 27	.218	0.464	.264 ± .007	91.4	99.3
-4-w	4	133 x 25	.272	0.279	.320 ± .008	145	153
-2-w	2	665 x 30	.345	0.183	.400 ± .012	227	247
-0-w	0	1,045 x 30	.432	0.116	.490 ± .016	347	377

TABLE II. PERFORMANCE DETAILS

DASH NO.	ABRASION RESISTANCE (Procedure 1)				BEND TESTING				
	MINIMUM RESISTANCE (INCHES OF TAPE)	WEIGHT SUPPORT BRACKET	WEIGHT (LBS)	TENSION LOAD (LBS)	MANDREL DIAMETER (INCHES-MAX.)			TEST LOAD (LBS)	
					LIFE CYCLE TEST AND ACCELERATED AGING TEST	COLD BEND TEST	WRAP TEST	LIFE CYCLE TEST AND ACCELERATED AGING TEST	COLD BEND TEST
-24-w	12	A	1.0	1	1/2	1	1/4	0.5	3.0
-22-w	22	A	1.0	1	3/4	1	1/4	1.5	3.0
-20-w	22	A	1.0	1	3/4	1	1/4	2.0	4.0
-18-w	22	A	1.0	1	1	1 1/2	3/8	2.0	4.0
-16-w	30	A	1.0	2	1	1 1/2	3/8	2.0	5.0
-14-w	17	B	3.0	2	1 1/2	2	1/2	2.0	5.0
-12-w	17	B	3.0	2	2	2	1/2	2.0	5.0
-10-w	20	B	3.0	3	3	3	3/4	2.0	5.0
-8-w	25	B	3.0	3	3	4	3/4	3.0	6.0
-6-w	25	C	3.0	4	4	5	1	3.0	10.0
-4-w	33	C	4.25	4	5	6	1 1/4	3.0	10.0
-2-w	33	C	4.25	5	6	8	3	4.0	15.0
-0-w	48	C	4.25	5	8	10	4	4.0	15.0

REQUIREMENTS

TEMPERATURE RATING: 150°C (302°F)
 Max. Conductor Temperature
 VOLTAGE RATING: 600 volts (rms)
 PHYSICAL PROPERTIES (Primary Insulation)
 Tensile Strength, 2500 psi (min.), sizes 24-12
 2000 psi (min.), sizes 10-0
 Elongation, 150% (min.)
 INSULATION FLAWS (Spark Test)
 Primary insulation, 3000 volts/60 cps (rms), 100% test
 Finished wire, 5000 volts/60 cps (rms), 100% test
 BLOCKING: 225 ± 3°C for 6 hours
 DIELECTRIC TANK TEST: 2500 volts/1 min, 60 cps (rms) 100% test
 INSULATION RESISTANCE: 5000 megohms for 1000 ft. (min.)
 THERMAL SHOCK RESISTANCE: 150°C. Max. change 0.06 inch
 SHRINKAGE: 300 ± 3°C, 1/8 inch (max.) in 12 inches, sizes 24-12
 1/4 inch (max.) in 12 inches, sizes 10-0
 WICKING: 1/4 inch (max.)
 DIELECTRIC TEST: 2500 volts/5 min, 60 cps (rms)
 LOW TEMPERATURE (Cold Bend): 2 turns (720°)
 COLOR: White preferred

FLAMMABILITY: 30 sec. (max.); 3 inches (max.); no flaming of tissue paper
 LIFE CYCLE: 200 ± 3°C for 168 hours
 ACCELERATED AGING: 300 ± 3°C. Identification legibility 225 ± 3°C
 HUMIDITY RESISTANCE: Insulation Resistance 5000 megohms for 1000 ft. (min.)
 SURFACE RESISTANCE: 500 megohms-inches (min.), both readings
 SMOKE: 200 ± 3°C. No visible smoke
 IDENTIFICATION OF PRODUCT: Required
 COLOR STRIPING DURABILITY: 125 cycles (250 strokes) (min.)
 IDENTIFICATION DURABILITY: 125 cycles (250 strokes) (min.)
 DASH NO: The "w" in tables above shall be replaced by a color code designator in accordance with MIL-STD-681.
 PART NO: The part number shall consist of the military part number indicator, spec. sheet no., and dash no.

M 81044/9 -20-9
 Military Part No, Indicator Spec. Sheet No. Dash No.
 Example: Size 20, White: M 81044/8 -20-9,
 White with orange stripe: M 81044/9 -20-93.

THIS SPECIFICATION SHEET TAKES PRECEDENCE OVER DOCUMENTS REFERENCED HEREIN. REFERENCED DOCUMENTS SHALL BE OF THE ISSUE IN EFFECT ON DATE OF INVITATIONS FOR BID.

FSC 6145

MIL W-81044/9(AS)

NOTE:

The resistance of the insulation of this wire to "cut-through"* decreases with increasing temperature. Therefore, for applications where total conductor temperatures# are expected to exceed 110°C, use of this wire shall be restricted to installations where special precautions are taken to preclude stresses which can result in cut-through damage to the wire.

* CUT-THROUGH is damage which results from localized stresses such as are caused by thin or sharp edges, lacing cords or ties, mounting clamps etc.

TOTAL CONDUCTOR TEMPERATURE is the operating temperature of the conductor of the wire. It is the sum of the ambient temperature plus the temperature rise caused by the current carried by the wire.

*U.S. GOVERNMENT PRINTING OFFICE: 1967-251-519/5905

APPENDIX III

MIL-C-26500

Connector Specification

U. S. AIR FORCE
SPECIFICATION
NOTICE

MIL-C-26500D(USAF)
NOTICE 1
18 Nov 1971

MILITARY SPECIFICATION

CONNECTORS, GENERAL PURPOSE, ELECTRICAL
MINIATURE, CIRCULAR, ENVIRONMENT RESISTING
GENERAL SPECIFICATION FOR

This Notice should be filed in front of or in place of
Military Specification MIL-C-26500D(USAF), dated
10 November 1970.

1. MIL-C-26500D(USAF) is inactive for new design by the Air Force.
2. For Air Force applications use MIL-C-38999 or MIL-C-83723.

★U.S. GOVERNMENT PRINTING OFFICE:1972-714-102/4549

Preparing Activity:
Air Force 17

FSC 5935

MIL-C-26500D(USAF)
 AMENDMENT 2
 15 November 1971
 SUPERSEDING
 AMENDMENT 1
 26 January 1971

MILITARY SPECIFICATION

CONNECTORS, GENERAL PURPOSE, ELECTRICAL,
 MINIATURE, CIRCULAR, ENVIRONMENT RESISTING,
 GENERAL SPECIFICATION FOR

This amendment forms a part of Military Specification MIL-C-26500D(USAF), dated 10 November 1970, and is mandatory for use by the Department of the Air Force.

Page 1

- * 1.2 (f), line 1: Delete "Five" and substitute "Six".

At end of paragraph, add "Firewall (Class K)."

Page 2

- * Under Federal Specifications, insert:

"QQ-P-35 Passivation Treatments for Austenitic, Ferritic, and Martensitic Corrosion-resisting Steel (fastening devices).
 QQ-S-763 Steel Bars, Shapes, and Forgings-Corrosion Resisting."

Page 4

- * Under Military Standards, insert:

"MS27657 Short Support, Cable, Electrical Connector (for Class E and K Connectors).
 MS27658 Long Support, Cable, Electrical Connector (for Class E and K Connectors).
 MS27659 90° Support, Cable, Electrical Connector (for Class E and K Connectors)."

Page 10

- * 3.2.7: Add

"h. For Classes E and K in stainless steel materials, short cable support fitting in accordance with MS27657.

i. For Classes E and K in stainless steel materials, long cable support fitting in accordance with MS27658.

j. For Classes E and K in stainless steel materials, 90° cable support fitting in accordance with MS27659."

- * 3.3: At the end of paragraph, add "Classes E and K, stainless steel, shall be passivated in accordance with QQ-P-35."

Page 35

- * 4.7.13, line 5: Delete "50" and substitute "100".

FSC 5935

MIL-C-26500D(USAF)
AMENDMENT 2

Page 44

6.3, delete and substitute:

"6.3 **Qualification.** With respect to products requiring qualification, awards will be made only for products which are, at the time set for opening of bids, qualified for inclusion in the applicable Qualified Products List whether or not such products have actually been listed by that date. The attention of the suppliers is called to this requirement, and manufacturers are urged to arrange to have the products that they propose to offer to the Federal Government tested for qualification, in order that they may be eligible to be awarded contracts or orders for the products covered by this specification. The activity responsible for the Qualified Products List is the Rome Air Development Center, Griffiss AFB, NY 13440; however, information pertaining to qualification of products may be obtained from the Defense Electronics Supply Center (DESC-E), Dayton, Ohio with "Provisions Governing Qualification" (see 6.3.1)."

* Add new paragraph:

"6.3.1 Copies of "Provisions Governing Qualification" may be obtained upon application to Commanding Officer, Naval Publications and Forms Center, 5801 Tabor Avenue, Philadelphia, PA 19120."

* The margins of this amendment are marked with asterisks to indicate where changes from the previous issue were made. This was done as a convenience only and the Government assumes no liability whatsoever for any inaccuracies in these notations. Bidders and contractors are cautioned to evaluate the requirements of this document based on the entire content irrespective of the marginal notations and relationship to the last previous issue.

Review activities:
Air Force - 11, 80

Preparing activity:
Air Force - 17

Agent:
DSA - ES

(Project 5935-F744)

*U.S. GOVERNMENT PRINTING OFFICE: 1972-714-162/4659

Page 2
of 2 pages

MIL-C-26500D (USAF)

10 November 1970

Superseding
MIL-C-26500C
26 June 1967

MILITARY SPECIFICATION

CONNECTORS, GENERAL PURPOSE, ELECTRICAL,
MINIATURE, CIRCULAR, ENVIRONMENT RESISTING,
GENERAL SPECIFICATION FOR

1. SCOPE

1.1 Scope. This specification covers an environment-resisting family of miniature, circular, electrical connectors (plugs and receptacles), designed to meet the requirements of advanced aircraft, rockets, missiles, and space vehicles.

1.2 This specification defines connectors with the following physical characteristics:

- (a) A series of plugs and receptacles in which the socket contact inserts have a resilient face, and the mating pin inserts may have either a resilient or a hard face. The available forms are as shown below:
- (b) Coupling types - Threaded (Type T) and Bayonet (Type B).
- (c) Nine shell sizes. (8, 10, 12, 14, 16, 18, 20, 22 and 24).
- (d) Various contact arrangements and sizes, including low frequency shielded contacts (Figure 1 of Supplement 1).
- (e) Six different shell polarization positions.
- (f) Five classes - Environment resisting (Class R); Hermetic (Class H); Stainless steel (Class E); Fluid resisting (Class F); Grounding (Class G).
- (g) Contact styles - "P" pin, "S" socket, "C" pin solder cup, "E" pin solder eyelet (styles C&E only for hermetic).

FSC 5935

MIL-C-26500D (USAF)

2. APPLICABLE DOCUMENTS

2.1 The following documents, of the issue in effect on date of invitation for bids or request for proposal, form a part of this specification to the extent specified herein:

SPECIFICATIONS

Federal

QQ-A-367	Aluminum Alloy Forgings, Heat Treated
L-P-378	Plastic Film (Polyethylene Thin Gauge)
PPP-B-566	Boxes, Folding, Paperboard
PPP-B-585	Boxes, Wood, Wirebound
PPP-B-591	Boxes, Fiberboard
PPP-B-601	Boxes, Wood, Cleated-Plywood
PPP-B-621	Boxes, Wood, Nailed and Lock-Corner
PPP-B-636	Box, Fiberboard
PPP-B-676	Boxes, Set-Up, Paperboard

Military

MIL-M-14	Molding Plastics and Molded Plastic Parts, Thermosetting
MIL-P-116	Preservation, Methods of
MIL-H-5606	Hydraulic Fluid, Petroleum Base, Aircraft, Missile and Ordnance
MIL-J-5624	Turbine Fuel, Grades JP-4 and JP-5
MIL-S-7742	Screw Threads, Standard, Optimum Selected Series, General Specification for
MIL-L-7808	Lubricating Oil, Aircraft, Turbine Engine, Synthetic Base
MIL-A-8625	Anodic Coatings, for Aluminum, and Aluminum Alloys
MIL-L-8937	Lubricant, Solid Film, Heat Cured
MIL-L-9236	Lubricating Oil, Aircraft Turbine Engine, 400°F
MIL-L-10547	Liners, Case and Sheet, Overwrap, Water-Vapor proof, or Waterproof, Flexible
MIL-W-16878	Wire, Electrical, Insulated, High Temperature
MIL-I-17214	Indicator, Permeability, Low-Mu "Go-no-Go"
MIL-W-22759	Wire, Electrical, Fluorocarbon, Insulated, Copper and Copper Alloy
MIL-L-23699	Lubricating Oil, Aircraft and Turbine engines, Synthetic Base

MIL-C-26500D (USAF)

MIL-C-45662 Calibration System Requirements

STANDARDS

Federal

FED-STD-406 Plastics, Methods of Testing

Military

MIL-STD-105 Sampling Procedures and Tables for Inspection by Attributes

MIL-STD-129 Marking for Shipment and Storage

MIL-STD-202 Test Methods for Electronic and Electrical Component Parts

MIL-STD-454 Standard General Requirements for Electronic Equipment

MS24254 Contact-Electrical Connector, Male, Removable

MS24255 Contact-Electrical Connector, Female, Removable

MS24264 Connectors, Receptacle, Electrical-Flange Mount Miniature

MS24265 Connectors, Receptacle, Electrical-Single Hole Mount, Miniature

MS27034 Connector, Receptacle, Electrical, Pin Insert, Cylindrical, Miniature, Hermetic, Solder Mount

MS27186 Plug, End, Seal, Electrical Connector Size 16, 20, and 50 ohm coaxial

MS27187 Plug, End, Seal, Electrical Connector Size 12, 16, and 22

MS27290 Bushing, Cable Adapter

MS27291 Support, Cable, Electrical Connector

MS27292 Cap, Electrical Connector Plug, Protective, Metal, Threaded Coupling

MS27293 Cap, Electrical Connector Plug, Protective, Metal, Bayonet Coupling

MS27294 Cap, Electrical Connector, Receptacle, Protective, Metal, Threaded Coupling

MS27295 Cap, Electrical Connector, Receptacle, Protective, Metal, Bayonet Coupling

MS27296 Connector, Receptacle, Electrical, Dummy Stowage, Threaded Coupling

MS27297 Connector, Receptacle, Electrical, Dummy Stowage, Bayonet Coupling

MS27426 Tool Kit, Contact, Crimp Type, Electrical Connector

MIL-C-26500D (USAF)

MS27557	Adapter, Conduit, Right Angle
MS27558	Support, Cable, Right Angle, Closed
MS27559	Support, Cable, Right Angle

(Copies of specifications, standards, drawings, and publications required by suppliers in connection with specific procurement functions should be obtained from the procuring activity or as directed by the contracting officer).

3. REQUIREMENTS

3.1 Qualification. The connectors furnished under this specification shall be a product which has been qualified under paragraph 3.1.1 and shall be listed or approved for listing on the applicable qualified product list.

3.1.1 Qualification to this specification shall consist of proper demonstration that articles submitted for qualification meet all requirements contained herein.

3.1.2 In the event of conflict between this specification and the MS sheet listed on the supplement, the latter shall govern. In the event of conflict between this specification and the applicable document (Section 2), the requirements of this specification shall govern.

3.1.1.1 Family Qualification. Where it can be shown that a group of connectors constitutes a design series differing only in envelope dimensions, qualification of the entire series can be accomplished at the discretion of the qualifying agency by submitting the largest and smallest shell sizes to, and successfully passing, this specification. Proof of design similarity shall take into account but not necessarily be limited to the following considerations:

- a. That shell couplings are identical
- b. That component materials are identical
- c. That contacts are identical
- d. That contact spacing is identical, or at least that connector samples subjected to actual testing include those exhibiting the closest contact to contact and contact to shell spacing.

MIL-C-26500D (USAF)

3.2 Military Standards for individual connectors. All requirements herein apply to all connectors covered by the applicable military standards listed in this specification and supplement. Each complete plug or receptacle is an assembly of specific parts, such as:

- a. Body, comprising the shell, dielectric inserts, and on plugs, the coupling ring.
- b. Contacts, pin or socket type as specified.
- c. Plug end seal (except on hermetically sealed receptacles).
- d. Cap, protective plastic.
- e. Instruction Sheet (except for Class H).

3.2.1 Body - The design and construction of the body portion of the plug and receptacle shall be as follows:

3.2.1.1 Shell

*3.2.1.1.1 Shell material. The shell for the plug or receptacle for Classes R, F, and G shall be aluminum alloy 6061, temper T6, in accordance with QQ-A-367. Other materials for Classes R, F, and G will be permitted provided they show equal or better mechanical strength and meet the performance requirements herein. Shell material for Class E shall be 300 series stainless steel. All materials shall be corrosion resistant or protected to meet the performance requirements herein. The shell material for the hermetic receptacles shall be suitable for soldering or brazing to a mounting surface of steel or aluminum alloy.

3.2.1.1.2 Shell keying. The polarization of the mating plug and receptacles shall be accomplished by means of integral keys and keyways on plug and receptacle shells, as shown on the applicable military standard. Keys shall be designed to prevent engagement of the contacts with the mating contacts or with the insert surface of the counterpart connector until the keyways are properly aligned for engagement.

3.2.1.1.3 Mating bodies. The shells and their inserts shall be designed to achieve a face-to-face seal, providing continuous electrical separation between contacts and between contacts and shell. A peripheral "O" ring seal shall be provided between the receptacle and plug shell. The seals thus provided shall be

MIL-C-26500D (USAF)

sufficient to allow the mated plug and receptacle to comply with the performance requirements specified herein. Complete mating of threaded types shall occur when the plug shell bottoms against the receptacle shell.

3.2.1.1.4 Receptacle shell. The single-hole mount receptacle shall be provided with an O-ring panel seal and nut with provisions for locking.

3.2.1.1.5 Coupling connection. The coupling ring of threaded and bayonet types shall be straight knurled or fluted and designed to assist in mating and unmating contacts as the coupling ring is tightened or loosened. It shall be possible to fully mate or unmate a counterpart plug and receptacle of any size and contact arrangement without the use of tools. The coupling ring shall be mechanically retained on the plug shell and shall provide positive retention of the plug and receptacle by means of solid shoulders on the coupling ring and plug shell. A plug with a bayonet coupling shall couple to its mating receptacle by rotating the coupling ring through 120° maximum as shown on the applicable military standard. The threaded coupling ring shall have three 0.035 diameter safety wire holes equally spaced.

3.2.1.1.6 Visual indicator of completed coupling.

3.2.1.1.6.1 Threaded coupling. A circumferential stripe of contrasting color with the shell, and which shall be a minimum of 0.025 inch in width, shall be placed on the threaded type receptacle and the dimension from the front edge of the receptacle to the far side of the stripe shall be 0.433 plus or minus 0.003 inch. The coupling ring shall cover the stripe when the connectors are completely mated.

3.2.1.1.6.2 Bayonet coupling. Three 0.025 plus or minus 0.010 inch wide axial stripes of contrasting color shall be placed on the bayonet coupled receptacle; the stripes shall coincide with the bayonet pin. The coupling ring shall have three similar stripes coinciding with the lock positions. The receptacle line and the coupling ring line shall align within 0.015 inch when the connectors are completely mated.

3.2.1.1.7 Screw threads. Screw threads shall be in accordance with MIL-S-7742. Out-of-roundness is not objectionable if the threads can be checked without forcing the thread gauges. All thread surfaces including the lead thread shall be smooth enough that they will not be galled, cut, or otherwise damaged by mating, or cause damage to the mating connector. All threads shall be continuous

MIL-C-26500D (USAF)

and not broken or interrupted, except where otherwise required by the military standard.

3.2.1.1.8 Lubrication. Internal coupling ring threads shall be coated with a lubricant conforming to MIL-L-8937.

3.2.1.1.9 Rear connector seal - Sealing of the wires and back of the connectors shall be accomplished without aid of auxiliary compression devices.

3.2.1.2 Insert

3.2.1.2.1 Insert construction. The inserts shall be designed and constructed to eliminate all air paths between contacts. The socket insert face shall be of a resilient material. An integrally molded resilient static peripheral seal shall be provided that will effect a seal before mating is completed, as shown on the military standard. The entire insert and wire sealing member shall function as an integral part. Its separate parts shall be bonded and shall provide suitable sealing around the wire shown in Table I for the appropriate contact sizes. The inserts shall be so designed that positive locking of the contacts in the inserts is provided. The contact retaining device shall be free of foreign material, adhesive, or any obstruction that would prevent contact insertion and positive retention. Contacts for the hermetic receptacle shall be fused in place with vitreous material and a resilient gasket shall be cemented to the face of the insert. No metal lattice material shall be used. All materials used for inserts shall meet Resistance to Arc requirements of 3.6.20.

TABLE I WIRE SEALING ACCOMMODATION OF CONTACT SIZES AND WIRE DIMENSIONS		
Contact Size	Range of Outside Diameter of all Insulated Conductors (INCHES)	Wire Gauge to which Contact is required to Crimp
No. 20	0.040 to 0.090	No. 24, 22, or 20
No. 16	0.068 to 0.130	No. 20, 18, or 16
No. 12	0.106 to 0.170	No. 14 or 12
Shielded	0.095 to 0.145	No. 22, 20, and 18

MIL-C-26500D (USAF)

3.2.1.2.2 Contact alignment and stability. With all contacts properly inserted into the connector, the alignment of pin and socket contacts shall always permit engagement irrespective of buildup of misalignment tolerances such as tolerances allowed on hole locations, and allowable distortion of contacts due to crimping. This requirement shall apply to unwired contacts having sealing plugs and to contacts wired with minimum or maximum size wire insulation or with contacts properly inserted having any combination of the above conditions.

3.2.1.2.3 Insert arrangement and marking of the insert. The insert arrangement shall be as specified by the connector part number and in accordance with the applicable military standards. The contact positions shall be marked by numbers and a line in accordance with the applicable MS standard. The size of the numbers shall be as large as practicable and no less than 3/64 inch in height. The contact positions shall be permanently designated in contrasting color on the front and rear faces of the insert. The marking on mating faces shall be of opposite rotation so that, when mated, contacts of the same identification number shall mate with each other. The marking shall be legible on all samples after all tests.

3.2.1.3 Part numbering and marking. The connectors shall be clearly and permanently marked. Insofar as is practical, the marking shall be readable after the connector is mounted on equipment. All letters and numbers shall be a minimum of 3/64 inch in height and shall be legible after any test sequence required by this specification. Each connector shall be marked on the shell or coupling ring with the manufacturer's name or trademark and with the appropriate MS part number, as in the following example:

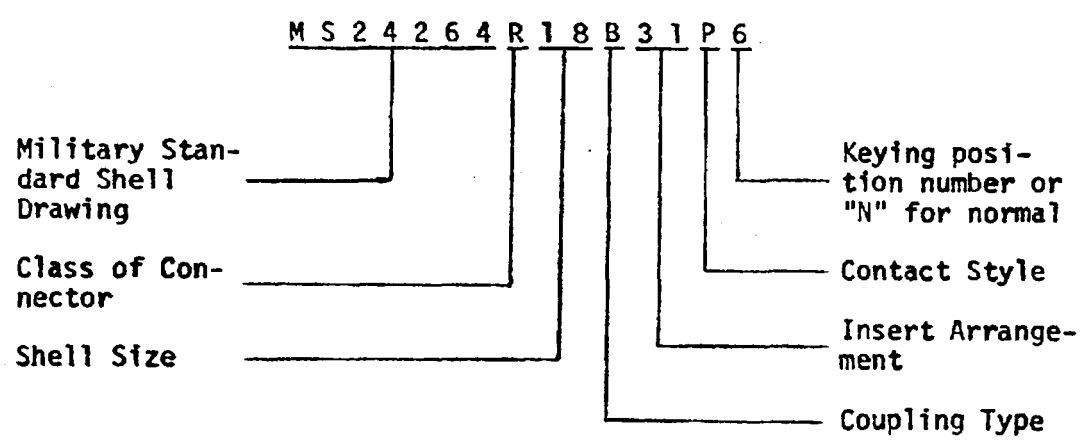

MIL-C-26500D (USAF)

The manufacturer's symbol for purge control shall also appear on each connector, but shall not be marked in direct association with the part number.

*3.2.2 Contacts. All connectors, except the hermetic receptacles, shall be designed to meet the performance requirements of this specification, using contacts in accordance with MS24254 and MS24255. The contact style shall be as designated in the connector part number and the size as shown on the applicable MS insert drawing.

3.2.2.1 Contacts for hermetic receptacles shall be made of suitable material plated to meet the performance and detail requirements of MS27034, MS24264 and MS24265 receptacles. Dimensions shall be as shown on the applicable military standard.

3.2.3 Plug, end seal. Sealing plugs shall be in accordance with MS27186 and MS27187.

3.2.4 Caps. Protective plastic dust caps shall be furnished in place on each end of each plug and receptacle for protection during shipping, storage, and assembly.

3.2.5 Installation instruction sheet. Except for Class H, an installation instruction sheet shall be furnished and shall specify the proper application, assembly, wiring, mounting, and installation of the specific plug or receptacle. The paper and printing shall be sulphur free. The manufacturer's name and address may appear on the instruction sheet.

*3.2.6 Tools. Except for Class H, contacts shall be insertable and removable from the connectors and wires shall be attachable to contacts with tools contained in tool kit, contact, crimp type Electrical-Connector MS27426.

3.2.7 Accessories. The accessories are not an integral part of the connector. The connector shall perform as specified when applicable accessories are used. Unless otherwise shown on the military standard, the accessories are as follows:

- a. For Classes R, G, and F in aluminum shell materials, cable support fitting in accordance with MS27291.
- b. For Classes R, G, and F in aluminum shell materials, cable adapter bushing in accordance with MS27290, used to cushion the bundle of wires in the cable support.

MIL-C-26500D (USAF)

- c. For Classes R, G, and F in aluminum shell materials right angle conduit adapter in accordance with MS-27557.
- d. For Classes R, G, and F in aluminum shell materials closed right angle cable support fitting in accordance with MS27558.
- e. For Classes R, G, and F in aluminum shell materials right angle cable support fitting in accordance with MS27559.
- f. A dummy stowage receptacle in accordance with MS-27296 or MS27297, as applicable. When the plug is coupled to its applicable dummy stowage receptacle, the mated assembly shall be sealed to prevent accumulation of dust, dirt, grease, oils, vapors, and other foreign substances on the face of the plug which could result in contamination.
- g. A protective metal cap MS27292, MS27293, MS27294 or MS27295, as applicable. When the cap is coupled onto the receptacle or plug, the mated assembly shall prevent accumulation of dust, dirt, grease, oils, vapors, and other foreign substances on the face of the receptacle which could result in contamination.

3.3 Finish. Aluminum parts on other than Class G connectors shall be anodic coated to Type III, with a minimum thickness of 0.001 inch, Class 2, dark gray to black color and shall be sealed per MIL-A-8625, except where shown or otherwise on the military standard. The finish of hermetic receptacles shall be suitable for soldering or brazing to the mounting surface. The finish on Class G connectors shall be such as to provide an electrically conductive path from the cable clamp screws on the plug to the receptacle mounting flange and shall meet the other requirements herein.

3.4 Dissimilar Metals. Unless otherwise protected against electrolytic corrosion, dissimilar metals shall not be employed in intimate contact with each other in a connector or in any mated pairs of connectors conforming to this specification. Dissimilar metals are defined in MIL-STD-454, Requirement 16.

3.5 Interchangeability. Any plug and receptacle assembly, including its complement of contacts, shall be completely interchangeable with any other plug or receptacle having the same

MIL-C-26500D (USAF)

assembly part number whether from the same or any other supplier who complies with this specification. All pin and socket contacts of the same part numbers shall be interchangeable whether from the same or any other supplier who complies with this specification.

3.6 Performance. When subjected to the environmental tests specified herein, connectors covered by this specification shall meet the following performance requirements.

3.6.1 Design and Construction. The connectors shall conform to all requirements of this specification and military standards in accordance with 4.7.1.

3.6.2 Torque to couple/uncouple. When mated with and unmated from counterpart connectors in accordance with 4.7.2 and 4.7.2.2, the connectors shall require torque within the limits of the applicable values in Table II.

TABLE II - TORQUE		
Shell Size	Torque for Types T & B (INCH POUNDS)	
	MAXIMUM With Contacts	MINIMUM UNCOUPLING Without Contacts
8	9	2.0
10	10	2.5
12	14	3.0
14	17	3.5
16	23	4.0
18	26	5.5
20	31	6.0
22	38	6.5
24	46	7.0

3.6.2.1 Torque to couple/uncouple - variables data. When tested in accordance with 4.7.2.1, it shall be demonstrated with 95% confidence that 99% of the design population require mating or unmating torques within the limits of the applicable values shown in Table II.

3.6.3 Contact Retention. When tested as specified in 4.7.3, the individual contact retention mechanism on unmated connectors shall retain the contact under the axial loads specified in Table III. During the test, the axial displacement of the contact shall not exceed 0.012 inch when pressures are applied to the mating end of the contact.

MIL-C-26500D (USAF)

3.6.3.1 Contact Retention - variables data. When tested in accordance with 4.7.3.1, it shall be demonstrated with 95% confidence that 99% of the design population have minimum contact retention capabilities which exceed the values given in Table III.

TABLE III AXIAL LOADS FOR CONTACT RETENTION TEST CLASS R, G, F, AND E	
Contact Size	Axial Loads (pounds)
20	20
16	25
12	30
#1 shielded	30
#2 shielded	45

3.6.4 Contact Insertion/Removal Forces. Except for Class H, when tested as specified in 4.7.5, the individual contact insertion forces shall not exceed 15 pounds. Individual removal forces shall not exceed 10 pounds.

3.6.4.1 Contact Insertion/Removal Forces - variables data. Except for Class H, when tested in accordance with 4.7.5.1, it shall be demonstrated with 95% confidence that 99% of the design population shows contact insertion forces of 15 pounds or less, and contact removal forces of 10 pounds or less.

3.6.5 Insulation Resistance. When tested as specified in 4.7.7, the insulation resistance shall be greater than 5000 megohms when measured between two adjacent contacts and between the contact closest to the shell and the shell.

3.6.5.1 Insulation Resistance - variables data. When tested as specified in 4.7.7.1, it shall be demonstrated with 95% confidence that 99% of the design population exhibit insulation resistance exceed 5000 megohms between two adjacent contacts and between the contact closest to the shell and the shell.

*3.6.5.2 Insulation Resistance at High Temperature. When tested in accordance with 4.7.7.2, the insulation resistance of connectors shall be greater than 2000 megohms for Classes G, H, and R, and 100 megohms for Class F when measured separately between any two adjacent contacts and between the shell and any contact.

MIL-C-26500D (USAF)

*3.6.5.3 Insulation Resistance at High Temperature - variables data. When tested as specified in 4.7.7.3, it shall be demonstrated with 95% confidence that 99% of the design population exhibit insulation resistance exceed 2000 megohms for Classes G, H, and R and 100 megohms for Class F between two adjacent contacts and between the contact closest to the shell and the shell.

3.6.6 Dielectric Withstanding Voltage. When tested in accordance with 4.7.8, and at the voltage levels indicated by Table XII, connectors shall show no evidence of flashover or breakdown. Breakdown shall be said to have occurred when leakage current exceeds 2.0 mA upon application of high potential.

3.6.6.1 Dielectric Withstanding Voltage - variables data. When tested in accordance with 4.7.8.1, it shall be demonstrated with 95% confidence that 99% of the design population do not have breakdown or flashover at voltages under 1500 volts A.C.

3.6.6.2 Dielectric Withstanding Voltage, Altitude (mated). Completely wired and assembled connectors shall show no evidence of breakdown or flashover when tested in accordance with 4.7.8.2. Corona shall not be considered as breakdown.

3.6.6.3 Dielectric Withstanding Voltage, Altitude (mated) - variables data. Completely wired and assembled connectors shall be tested in accordance with 4.7.8.3, and it shall be demonstrated with 95% confidence that 99% of the design population will not breakdown or flashover under 1000 volts A.C. at 110,000 feet altitude simulation. Corona shall not be considered as breakdown.

3.6.6.4 Dielectric Withstanding Voltage, Altitude (unmated). Completely wired but unmated connectors shall show no evidence of breakdown or flashover when tested in accordance with 4.7.8.2. Corona shall not be considered as breakdown.

3.6.7 Fluid Immersion (Class R, G, and E). After immersion in fluids specified in 4.7.9 for the times and conditions specified, unmated connectors shall mate properly.

3.6.7.1 Fluid Immersion (Class F). After immersion in fluids specified and according to the cycling sequence of 4.7.9.1, unmated connectors shall mate properly. The insert shall not swell to the extent that will cause cracks or tears. The insert diameter shall not swell to the extent that its dimension changes by more than 15%. Inserts shall not show evidence of material reversion.

3.6.8 Vibration. When tested in accordance with 4.7.12 or 4.7.12.2 connectors shall not crack or break and there shall be no loosening

MIL-C-26500D (USAF)

of parts. Connectors shall be in full engagement during vibration and the coupling device shall not loosen as a result of vibration. Interruption of electrical continuity shall be no longer than one microsecond.

3.6.9 Physical Shock. During and after testing in accordance with 4.7.13, connectors shall show no sign of damage. Interruption of electrical continuity shall not exceed one microsecond.

3.6.10 Contact Resistance. When testing with a mating plug and in accordance with 4.7.11, the average contact resistance value of any 10 contacts of Class H connectors shall not exceed those in the table entitled "Contact Resistance" (Potential Drop) of MIL-C-26636 by more than 700 percent. No individual contact shall exceed the specified value by more than 1100 percent at 25° and 200°C. Contacts of mated Class R, G, F, and E connectors shall meet the requirements of table entitled "Contact Resistance" of MIL-C-26636.

3.6.10.1 Contact Resistance - variables data. In accordance with 4.7.11.1, it shall be demonstrated with 95% confidence that 99% of the design population exhibit contact resistance which is less than the maximum values stated in 3.6.10.

3.6.11 Thermal Shock. After testing in accordance with 4.7.6, connectors shall be unmated and show no evidence of cracking, fracture, or other damage detrimental to the connector. No material reversion shall be in evidence.

3.6.12 Moisture Resistance. During or after the test specified in 4.7.14, the insulation resistance values shall not be less than 1000 megohms.

3.6.13 Corrosion. After being tested in accordance with 4.7.15, the unmated connectors shall show no exposure of basic metal due to corrosion. Class H specimens shall be exposed unmated and shall meet the requirements of 3.6.10, on the first mating after corrosion testing.

3.6.14 Temperature Life. After subjection to the test of 4.7.16, the connectors shall perform satisfactorily and shall pass the succeeding tests in the qualification test sequence.

3.6.15, Ozone Exposure. At the end of the ozone exposure test of 4.7.17, the connectors shall evidence no cracking of materials or other damage that will adversely affect subsequent performance in

MIL-C-26500D (USAF)

the qualification test sequence.

*3.6.16 Magnetic Permeability. When tested per 4.7.18, the relative permeability of the connectors shall be less than 2. Class H receptacles are not subject to this requirement.

3.6.17 Insert Retention. When tested in accordance with 4.7.19, connectors less cable supports or any insert supporting accessory shall withstand an axial load of 75 PSI from either direction for a period of at least 5 seconds without being dislocated from their normal position in the shell.

*3.6.17.1 Insert Retention (Class H). When tested in accordance with 4.7.19.1, Class H connectors shall withstand a load as shown on Table IV either direction parallel to the axis of the connector, for a period of 5 seconds minimum, without displacement of contacts or insert. Connectors shall then meet the test specified in 3.6.18.1.

TABLE IV	
INSERT RETENTION LOADS (CLASS H)	
Shell Size	Load (PSI)
24	250
22	300
20	700
18	1000
16	1250
14	1750
12	2000
10	2750
8	3000

3.6.18 Air Leakage. When testing in accordance with 4.7.20, receptacles shall prevent leakage of more than one cubic inch of air per hour.

3.6.18.1 Air Leakage Class H Receptacles. When testing in accordance with 4.7.20.1, and when subjected to a pressure differential of 15 PSI across the receptacle, the receptacle shall not exhibit an air leakage rate that will produce a pressure change of more than 0.01 micron of mercury per cubic foot per hour (1×10^{-7} Standard cc/sec at 1 atmosphere). The specific leakage rate shall apply through the connector only and not through the brazed or welded joint between the connector and the mounting flange.

MIL-C-265000 (USAF)

*3.6.19 Altitude Immersion. When tested in accordance with 4.7.21, Class G, H, and R connectors shall maintain an insulation resistance of at least 5000 megohms and shall withstand a voltage of 1500 volts AC at sea level. Class F connectors shall maintain an insulation resistance of at least 1000 megohms and shall withstand a voltage of 1500 volts AC at sea level.

3.6.20 Resistance to Arc. The resistance to arc of insert material disc specimens, conforming to designation 2 of MIL-M-14, shall be a minimum of 115 seconds when tested in accordance with FED-STD-406, Test Method 4011, except as otherwise specified in 4.7.22.

3.6.21 Ground Resistance (Class G only). When tested in accordance with 4.7.23, the resistance shall not exceed 0.250 ohms.

3.7 Workmanship. Details or workmanship shall be in accordance with highgrade manufacturing practices for similar connectors. All sharp corners shall be broken and shall be smooth; shell surfaces shall be free from porosity, blow holes, burrs, and cracks.

4. QUALITY ASSURANCE PROVISIONS

4.1 Responsibility for inspection. Unless otherwise specified in the contract or purchase order, the supplier is responsible for the performance of all inspection requirements as specified herein. Except as otherwise specified, the supplier may utilize his own inspection facilities or any laboratory acceptable to the Government. The Government reserves the right to perform any of the inspections set forth in the specification where such inspections are deemed necessary to assure supplies and services conform to prescribed requirements.

4.1.1 Test equipment and inspection facilities. Test equipment and inspection facilities shall be of sufficient accuracy, quality and quantity to permit performance of the required inspection. The supplier shall establish calibration of inspection equipment to the satisfaction of the Government. Calibration of the standards which control the accuracy of inspection equipment shall comply with the requirements of MIL-C-45662.

4.2 Classification of inspection. The examination and testing of connectors (plugs and receptacles) shall be classified as follows:

MIL-C-26500D (USAF)

<u>TABLE V</u>	
INSPECTION B - MAJOR-MINOR DEFECTS	
MAJOR	MINOR
Inability to mate with counterpart	Poor exterior finish
Incorrect sealing rings	Sealing member flash
Incorrect wire entry hole	Incorrect exterior or outline dimensions not preventing engagement or mounting
Improper sealing member or connector dimensions preventing sealing	Omission of colored stripe
Omission or incorrect identification markings	
Defective insert	
Missing or defective contact-locking device	
Burrs capable of cutting	
Piece part missing	
Materials not meeting specification requirements	
Nonconformance to design and construction	
Poor workmanship	

MIL-C-26500D (USAF)

- a. Qualification inspection (Inspection C - see 4.4).
- b. Verification of qualification (Inspection D - see 4.5).
- c. Quality conformance inspection.
 - (1) Inspection of product for delivery (Inspection A & B - see 4.6.1.2 and 4.6.1.3).
 - (2) Inspection of preparation for delivery (see 4.6.2).

4.3 Inspection conditions. Unless otherwise specified herein, all inspections shall be performed in accordance with the test conditions specified in the general requirements of MIL-STD-202 and on sample units selected from the same inspection lot.

4.3.1 Disposition of inspected samples and defective items. Items damaged during inspections A and B and connectors subjected to inspections C and D shall not be delivered on the contract or purchase order.

*4.4 Qualification inspection. Inspection C shall be performed at a laboratory acceptable to the Government (see 6.3). Connectors shall be inspected to the requirements outlined in Tables VIII and IX in the sequence listed. A minimum of 30 independent readings shall be made for each test in Table IX. This inspection shall be performed at least once on samples of each new design connector or after a significant design or construction change is made. To determine if any changes have occurred, the manufacturer shall retain the items on which the qualification tests were performed along with the applicable manufacturing drawings. Examination of these drawings will provide the basis for deciding whether a change has been made, and discussion and agreement between technical representatives of the manufacturer and the qualifying agency will provide the basis for a decision on the significance of the change.

4.4.1 Selection of samples. The number and type of samples selected for subsection to Inspection C shall be in accordance with Tables VI and VII. The manufacturer shall establish the sample size to be used for qualification of his connectors. The sample lot size and associated acceptance level shall not be changed after the tests are started.

4.4.2 Preparation of samples. Tests per 4.7.2.2 and 4.7.12.2 must be run before wiring those samples which are to be subjected

TABLE VI
SAMPLE GROUPING - ATTRIBUTE TEST

Notes		1		2		3		4		5	
Total Sample Class R,G,E	Class F	Group I Class R,G,F,E	Group II Class R,G,F,E	Group III Class R,G,F,E	Group IV Class R,G,E,F	Group V Class R,G,E	Group VI Class H	Group VII Class H	Decision Accept	Decision Numbers Reject	
13	16	I-1 thru I-3	II-1 thru II-3	III-1 thru III-3	IV-1 thru IV-7	V-1	VI-1	VII-1	0	1	
33	38	I-1 thru I-8	II-1 thru II-8	III-1 thru III-8	IV-1 thru IV-14	V-1	VI-1	VII-1	1	2	
81	81	I-1 thru I-20	II-1 thru II-20	III-1 thru III-20	IV-1 thru IV-21	V-1	VI-1	VII-1	2	3	
125	128	I-1 thru I-31	II-1 thru II-31	III-1 thru III-31	IV-1 thru IV-35	V-1	VI-1	VII-1	3	4	
201	206	I-1 thru I-50	II-1 thru II-50	III-1 thru III-50	IV-1 thru IV-56	V-1	VI-1	VII-1	4	5	

- NOTES:**
1. Mated pairs of connectors.
 2. One pair of connectors, with plug and receptacle respectively mated to a QPL listed receptacle and plug produced by another qualified manufacturer.
 3. One hermetically sealed receptacle - mated with a QPL listed Class R, G, or E plug produced by a qualified manufacturer.
 4. One hermetically sealed receptacle - mated with a QPL listed Class R, G, or E plug produced by a qualified manufacturer other than the one used in Group VI.
 5. These numbers apply to Class R, G, F, and F connectors only. Acceptance number is zero for all cases involving hermetic seal connectors.

MIL-C-26500D (USAF)

to these tests.

- *a. For samples of the non-hermetic sealed types, one half the sample size of Tables VI and VII shall be wired with MIL-W-16878 or MIL-W-22759 wire with insulation of extruded construction as applicable. The wire gauge and insulation diameter shall be the smallest for which the contacts are designed, i.e., size 20-gauge wire and size 12 contacts with 14-gauge wire. The remaining half of the samples shall be wired with MIL-W-16878 or MIL-W-22759 wire where the wire gauge and insulation diameter shall be the largest for which the contacts are designed, i.e., size 20 contacts with 20-gauge wire, size 16 with 16-gauge wire and size 12 contacts with 12-gauge wire. In all test samples 5% of the contacts in each connector or one contact in each connector, whichever number is greater, shall not be wired, and the wire entry holes shall be filled with sealing plugs.
- b. The hermetic receptacles shall be wired with MIL-W-16878 or MIL-W-22759 wire with insulation of extruded construction. The wire gauge shall be the largest for which the contacts are designed, i.e., size 20 contacts with 20-gauge wire, size 16 with 16-gauge wire and size 12 contacts with 12-gauge wire. Only the tests applicable to hermetic receptacles need be conducted. The hermetic receptacles shall be mounted as in service on sealed metal cans for the altitude test.

*4.4.3 Accept-Reject Criteria. The total number of connectors failing to pass the inspection indicated in Table VIII shall not exceed the acceptance number for the plan chosen on Table VI, except that on the examination of product test, only failures involving interchangeability or those that require different tools or accessories will be counted. Other failures disclosed during the examination of product will require correction to the degree that articles produced and submitted for acceptance inspection will comply with individual and sampling inspection requirements.

4.5 Verification of qualification. Every 6 months the manufacturer shall compile the results of Inspection D tests, indicating the number and type of any part failures, and forward it to the qualifying activity as the basis of continued qualification approval. If the test results indicate nonconformance with specification requirements, action shall be taken to remove the failing product from the

TABLE VII MINIMUM SAMPLE SIZES FOR VARIABLES DATA				
	NOTES 1	2	3	4
Connector Designation	Thirty (30) Independent Electrical Measurements	Thirty (30) Independent Mechanical Measurements	Thirty (30) Independent Readings Involving Mated Pair As a Unit	Total Mated Pairs Req'd For Testing To Table VIII
24 - 61	3	1	30	30
24 - 43	4	2	30	30
22 - 55	3	1	30	30
22 - 32	5	2	30	30
22 - 19	8	3	30	30
22 - 12	10	4	30	30
20 - 41	4	2	30	30
20 - 39	4	2	30	30
20 - 28	5	2	30	30
20 - 25	5	2	30	30
20 - 16	8	3	30	30
18 - 31	4	2	30	30
18 - 14	10	3	30	30
18 - 11	10	3	30	30
18 - 8	15	5	30	30
16 - 24	6	3	30	30
16 - 10	10	5	30	30
14 - 15	6	3	30	30
14 - 12	15	4	30	30
14 - 7	15	8	30	30
14 - 4	30	8	30	30
14 - 3	30	15	30	30
12 - 12	10	4	30	30
12 - 3	30	15	30	30
10 - 20	30	15	30	30
10 - 5	30	15	30	30
10 - 2	30	15	30	30
8 - 2	30	15	30	30

- NOTES: 1. Test Paragraphs 4.7.7.1 and 4.7.7.3 - TABLE IX.
2. Test Paragraphs 4.7.5.1, 4.7.3.1, and 4.7.4 - TABLE IX.
3. Test Paragraphs 4.7.2.1, 4.7.8.1, 4.7.8.3, 4.7.10.1 and 4.7.11.1 - TABLE IX.
4. See Note - TABLE IX for instructions governing use of samples for more than one test. Note that test sequence TABLE IX is designed to allow use of fewest samples possible in completing variables data tests.

MIL-C-26500D (USAF)

qualified products list. Failure to submit the data shall result in loss of qualification for that product. In addition to the periodic submission of inspection data, the supplier shall immediately notify the qualifying activity at any time during the applicable period if the inspection data indicates failure that could cause changes in the qualification status of any qualified product.

4.5.1 Selection and preparation of samples. Inspection D shall consist of the tests specified in Table XI and IX, in the order shown, and shall be performed on sample units selected from inspection lots that have passed Inspections A and B. A minimum of 30 independent readings shall be made for each test in Table IX. The selection of samples and mating halves of test samples shall be in accordance with Tables X and VII. Selected samples shall be prepared in accordance with subparagraphs (a) and (b) of 4.4.2 Attributes inspection shall be performed on items presented for inspection before 20,000 connectors of the same part number have been produced since the preceding group was subjected to this inspection, but not more often than each 3 months and at least every 6 months. Variables tests need not be performed more often than once every 6 months.

4.5.2 Accept-Reject Criteria. The total number of failures to pass the inspection indicated in Table XI shall not exceed the acceptance number for the plan chosen in Table X. On the examination of product test, only failures involving interchangeability or those that require different tools or accessories will be counted.

4.6 Quality conformance inspection

4.6.1 Inspection of product for delivery. Inspection of product for delivery shall consist of Inspections A and B.

4.6.1.1 Inspection Lot. An inspection lot shall consist of connectors conforming to the same part number, manufactured by the same processes and with the same equipment, and submitted for acceptance at one time. Where production of connectors conforming to this specification is continuous, an inspection lot may be arbitrarily selected on a time span basis.

4.6.1.1.1 Test sample mating part. In order to economize on inspection, both plugs and receptacles may be subjected to inspection for acceptance even though they are on different contracts or purchase orders. Where this is not possible, the plug or receptacle to mate with the one under inspection shall be suitable for

MIL-C-26500 (USAF)

TABLE VIII QUALIFICATION INSPECTION C									
Test Description	Attribute Testing								
	Requirement Paragraph	Test Method Paragraph	Test Groups						
			I	II	III	IV	V	VI	VII
Examination of Product	3.6.1	4.7.1	X	X	X	X	X	X	X
Torque to Couple/Uncouple	3.6.2	4.7.2.2	X						
Vibration (Mated)	3.6.8	4.7.12.2	X						
Torque to Couple/Uncouple	3.6.2	4.7.2	X	X	X	X	X	X	X
Ground Resistance - Class G	3.6.21	4.7.23	X	X	X	X	X	X	X
Maintenance Aging	N/A	4.7.4	X	X	X	X			
Contact Insertion/Removal Force	3.6.4	4.7.5			X	X			
Durability	N/A	4.7.10	X				X		X
Thermal Shock	3.6.11	4.7.6	X	X	X	X	X	X	X
Dielectric Withstanding Voltage (Unmated)	3.6.6	4.7.8	X	X	X	X	X	X	X
Vibration (Mated)	3.6.8	4.7.12	X		X		X		X
Physical Shock	3.6.9	4.7.13	X						X
Moisture Resistance	3.6.12	4.7.14	X						X
Insulation Resistance	3.6.5	4.7.7	X						X
Corrosion	3.6.13	4.7.15	X						X
Temperature Life	3.6.14	4.7.16		X				X	
Insulation Resistance (high Temp)	3.6.5.2	4.7.7.2		X				X	X
Ozone Exposure (Unmated)	3.6.15	4.7.17			X				
Magnetic Permeability	3.6.16	4.7.18			X				
Insulation Resistance	3.6.5	4.7.7			X				
Insert Retention	3.6.17	4.7.19	X						
Insert Retention - Class H	3.6.17.1	4.7.19.1							X
Dielectric Withstanding Voltage (Unmated)	3.6.6	4.7.8	X	X	X			X	X
Air Leakage	3.6.18	4.7.20	X		X				
Air Leakage - Class H	3.6.18.1	4.7.20.1							X
Contact Retention	3.6.3	4.7.3	X	X	X			X	X
Altitude Immersion	3.6.19	4.7.21	X			X	X		X
Fluid Immersion - Class R, G, & E	3.6.7	4.7.9				X	X		
Fluid Immersion - Class F	3.6.7.1	4.7.9.1				X			
Torque to Couple/Uncouple	3.6.2	4.7.2	X	X	X	X		X	X
Insulation Resistance	3.6.5	4.7.7		X	X	X		X	X
Dielectric Withstanding Voltage (Mated at Altitude)	3.6.6.2	4.7.8.2		X	X	X		X	X
Dielectric Withstanding Voltage (Unmated at Altitude)	3.6.6.4	4.7.8.2	X	X				X	X
Contact Insertion/Removal Forces	3.6.4	4.7.5			X	X			
Contact Resistance	3.6.10	4.7.11		X					X
Examination of Product	3.6.1	4.7.1	X	X	X	X	X	X	X

MIL-C-26500D (USAF)

that purpose.

4.6.1.2 Inspection A (Individual 100 percent). All connectors submitted for compliance with this specification shall be inspected and comply with the following:

- a. All connector bodies meet the dielectric withstanding voltage requirements of 3.6.6 between adjacent contact retainers and contact retainers and shell.
- b. All contact retention devices are in place and provide the required contact retention of 3.6.3.
- c. Each hermetically sealed receptacle meets the air leakage requirement of 3.6.18.

*4.6.1.3 Inspection B (Sampling lot-by-lot). This inspection applies to those items that normally make up the kit of parts comprising the connector part number. The kit of parts shall be inspected for the presence of the proper parts, correctness of markings on connector container, the contact and plug end seal container, and the correct date code. At this time, a visual inspection shall be made of the piece parts for defects listed in Table V. Any defects shall be corrected, and if this inspection shows improper piece parts beyond that allowed by 4.6.1.3.1, the lot shall be rejected until the piece parts are corrected.

4.6.1.3.1 Sampling plan. Statistical sampling and inspection shall be in accordance with MIL-STD-105 for general inspection level II. The acceptable quality level (AQL) shall be 1.0 for major defects and 4.0 for minor defects as defined in Table V. Major defects are those that interfere with the mating interchangeability of connectors and their electrical functioning. Minor defects are those that are objectionable, but do not render a connector useless.

4.6.1.3.2 Rejected lots. If an inspection lot is rejected, the manufacturer shall withdraw the lot, or rework it to correct the defects, or screen out the defective units, as applicable, and reinspect. Such lots shall be separate from new lots, and shall be clearly identified as reinspected lots. Rejected lots shall be inspected using tightened inspection.

4.6.2 Inspection of preparation for delivery. Sample packages and packs shall be selected and inspected in accordance with the schedule of acceptance tests and visual inspection aids of MIL-P-

TABLE IX INSPECTION C - QUALIFICATION INSPECTION			
TEST DESCRIPTION	VARIABLES TESTING		
	Requirement Paragraph	Test Method Paragraph	Type of Test
Torque to Couple/Uncouple	3.6.2.1	4.7.2.1	Non-Destructive
Contact Insertion-Removal Force	3.6.4.1	4.7.5.1	Non-Destructive
Insulation Resistance	3.6.5.1	4.7.7.1	Non-Destructive
Durability	N/A	4.7.10.1	Non-Destructive
Torque to Couple/Uncouple	3.6.2.1	4.7.2.1	Non-Destructive
Contact Resistance	3.6.10.1	4.7.11.1	Non-Destructive
Insulation Resistance (High Temp)	3.6.5.3	4.7.7.3	Non-Destructive
Dielectric Withstanding Voltage (Mated)	3.6.6.1	4.7.8.1	Non-Destructive
Dielectric Withstanding Voltage (Mated at Altitude)	3.6.6.3	4.7.8.3	Destructive-Electrical Destructive-Electrical
Contact Retention	3.6.3.1	4.7.3.1	Destructive-Mechanical
Maintenance Aging	N/A	4.7.4	Non-Destructive
Contact Retention	3.6.3.1	4.7.3.1	Destructive-Mechanical

NOTES: See Table VII for minimum sample sizes.

Connectors subject to non-destructive tests may be used for subsequent tests.
Connectors subject to electrically destructive tests may be subjected only to follow-on tests which are purely mechanical. Connectors subjected to mechanically destructive tests may not be tested further.

MIL-C-26500D (USAF)

116, to verify conformance with the requirements of Section 5 of this specification.

4.7 Methods of examination and test.

4.7.1 Examination of Product. The connectors and piece parts shall be examined to insure conformance to all physical, mechanical, and size and weight requirements of this specification and the applicable military standards.

4.7.2 Torque, to couple and uncouple. While applying a coupling or an uncoupling force to the coupling ring at a uniform rate of approximately 4 inch-pound per second, the torque required to mate and unmate the plug from its counterpart shall be measured and recorded. The requirements of 3.6.2 shall be met.

4.7.2.1 Torque to couple and uncouple - variables data. While applying a coupling or an uncoupling force to the coupling at a uniform rate of approximately 4 inch-pound per second, the torque required to mate and unmate the plug from its counterpart shall be measured and recorded. Data shall be reduced in accordance with 6.4, and the requirement of 3.6.2.1 shall be demonstrated.

4.7.2.2 Torque to couple and uncouple - no contacts. With no contacts in the connectors, measurements shall be made in accordance with 4.7.2.

4.7.3 Contact retention. An axial load, as shown in Table III, shall be applied to the mating end of the contacts in unmated connectors. The axial rate of load application shall be approximately 4 pound per second. Contact movement shall be measured after contact is firmly seated on the retention member. The connector shall have all the contacts in place during the test and shall meet the requirements of 3.6.3.

4.7.3.1 Contact retention - variables data. An axial load shall be applied to the mating end of the contacts in unmated connectors. The axial rate of load application shall be approximately 4 pound per second until the contact moves axially a distance greater than .012". Contact movement shall be measured after contact is firmly seated on the retention member. The test shall not be applied to adjacent contacts (See Figure 1b). The maximum load shall be recorded and upon analysis in accordance with 6.4 shall meet the requirements of 3.6.3.1.

4.7.4 Maintenance aging. Before any environmental tests are conducted, each contact shall be inserted, removed, and reinserted

TABLE X
SAMPLE GROUPING - INSPECTION D - VERIFICATION OF QUALIFICATION

NOTES 1		Group I		Group II		Group III		Group IV		Decision Numbers	
Class R,G,E	Class F	Class R,G,F,E	Class R,G,F	Class F	Class R,G,F,E	Class R,G,F,E	Class H	Accept	Reject	Accept	Reject
6	11	I-1 and I-2	II-1 and II-2	II-1 thru II-7	III-1 and III-2	IV-1	0	1			
21	27	I-1 thru I-7	II-1 thru II-7	II-1 thru II-7	III-1 thru III-7	IV-1	0	2			
33	36	I-1 thru I-11	II-1 thru II-11	II-1 thru II-14	III-1 thru III-11	IV-1	1	3			
81	82	I-1 thru I-27	II-1 thru II-27	II-1 thru II-28	III-1 thru III-27	IV-1	2	5			
201	204	I-1 thru I-67	II-1 thru II-67	II-1 thru II-70	III-1 thru III-67	IV-1	3	6			

- NOTES:**
1. Based on MIL-STD-105, reduced inspection 1%, mated pairs.
 2. One connector - hermetically sealed receptacle - mated with a plug produced by a qualified manufacturer.
 3. These numbers apply only to Class R, G, F, and E connectors, Acceptance number is zero in all cases for Class H connectors due to the reduced sample size. Where accept number is exceeded by reject number is not reached, accept test lot but go to Table VI for sample size when next Verification of Qualification is run.

MIL-C-26500D (USAF)

using applicable insertion and removal tools. The same contacts shall be used throughout this aging and subsequent tests. The connector shall be mated and unmated 10 times. 20% of the contacts, but not less than 3 contacts in both plugs and receptacles, shall be removed and inserted 9 times, using applicable insertion and removal tools. Pairs of adjacent contacts and contacts adjacent to the shell shall be cycled, with the total number of contacts cycled being in accordance with requirements of this paragraph. The purpose of the procedure is to provide accelerated maintenance aging of the contact, contact locking mechanism, and sealing provisions prior to environmental testing.

4.7.5 Contact insertion and removal forces. The forces required to push the wired contacts into their normal position within the insert and to remove them, using the applicable insertion or removal tool, shall be measured. Unless otherwise specified, 20% but not less than 3 contacts in both plugs and receptacles shall be measured. Measurements shall be taken on one contact at a time with all other contact holes filled with wired contacts or contacts followed by sealing plugs. Connectors shall meet the requirements of 3.6.4.

4.7.5.1 Contact insertion and removal forces - variables data. The forces to push the contacts into their normal position within the insert and to remove them, using the applicable insertion or removal tool, shall be measured. Measurements shall be taken on one contact at a time with all other contact holes filled with wired contacts or contacts followed by sealing plugs. Connectors shall meet the requirements of 3.6.4. The measurements shall be recorded, and the data shall be analyzed in accordance with 6.4 and meet the requirements of 3.6.4.1.

4.7.6 Thermal Shock. The wired, mated connectors shall be subjected to 5 continuous cycles of temperature change. The two temperature extremes shall form the limits of the cycle, which shall be $-55^{\circ}\text{C} + 3^{\circ}\text{C}$ and $+260^{\circ}\text{C} + 3^{\circ}\text{C}$ for Classes R, H, G, and E and $+200^{\circ}\text{C} + 3^{\circ}\text{C}$ for Class F. The first exposure shall be from room temperature to the lowest extreme. The connectors shall be maintained at each extreme for a period of $30 +5 -0$ minutes in each cycle.

The connectors shall be transferred from one chamber to the other for the temperature changes. The time of exposure at room temperature shall not exceed 2 minutes during each transfer. Exposure to low temperature, then high, shall form one cycle. Upon completion of the last cycle, the connectors shall be returned to room ambient conditions for inspection to the requirements of 3.6.11 and

MIL-C-26500D (USAF)

TABLE XI						
INSPECTION D (VERIFICATION OF QUALIFICATION) ORDER OF TESTS						
Test Description	Requirements Paragraph	Test Method Paragraph	Test Groups (TABLE X)			
			I	II	III	IV
Examination of Product	3.6.1	4.7.1	X	X	X	X
Maintenance Aging	N/A	4.7.4	X	X	X	
Thermal Shock	3.6.11	4.7.6	X	X	X	X
Dielectric Withstanding voltage (Unmated)	3.6.6	4.7.8	X			X
Moisture Resistance	3.6.12	4.7.14		X		
Insulation Resistance	3.6.5	4.7.7		X		
Temperature Life	3.6.14	4.7.16	X			
Insulation Resistance (High Temp)	3.6.5.2	4.7.7.2	X			
Air Leakage	3.6.18	4.7.20	X			
Air Leakage (Class H)	3.6.18.1	4.7.20.1				X
Altitude Immersion	3.6.19	4.7.21		X	X	
Fluid Immersion (Class R, G, E)	3.6.7	4.7.9		X		
Fluid Immersion (Class F)	3.6.7.1	4.7.9.1		X		
Torque to Couple/ Uncouple	3.6.2	4.7.2	X	X	X	X
Dielectric Withstanding Voltage (Mated, Altitude)	3.6.6.2	4.7.8.2		X		
Dielectric Withstanding Voltage (Unmated, Altitude)	3.6.6.4	4.7.8.2	X		X	X
Examination of Product	3.6.1	4.7.1	X	X	X	X

MIL-C-20500D (USAF)

additional specified tests.

4.7.7 Insulation resistance. The connectors shall be tested in accordance with MIL-STD-202, Method 302, Test Condition B. For test purposes, the resistance shall be measured separately between the closest 3 pairs of adjacent contacts, which were inserted and removed 10 times in maintenance aging and between the contact closest to the shell and the shell. The requirements of 3.6.5 shall be met.

*4.7.7.1 Insulation resistance - variables data. The connectors shall be tested in accordance with MIL-STD-202, Method 302, Test Condition B. For test purposes, the resistance shall be measured as specified in 4.7.7. The insulation resistance values shall be recorded. The data shall be analyzed in accordance with 6.4 and meet the requirements of 3.6.5.1.

*4.7.7.2 Insulation resistance at high temperature. The insulation resistance of mated connectors shall be measured in accordance with 4.7.7 except that the connectors shall have been exposed to an ambient temperature of $200^{\circ} + 3^{\circ} - 0^{\circ}\text{C}$ for Classes R, H, G, and E and $175^{\circ} + 3^{\circ} - 0^{\circ}\text{C}$ for Class F for a period of 30 minutes; after which, the resistance shall be measured while the connector is at the elevated temperature. The requirements of 3.6.5.2 shall be met.

*4.7.7.3 Insulation resistance at high temperature - variables data. After connectors have been exposed to a temperature of $200^{\circ} + 3^{\circ} - 0^{\circ}\text{C}$ for Classes R, H, G, and E and $175^{\circ} + 3^{\circ} - 0^{\circ}\text{C}$ for Class F for a period of 30 minutes, the connectors shall be tested in accordance with MIL-STD-202, Method 302, Test Condition B. For test purposes, the resistance shall be measured as specified in 4.7.7. The insulation resistance values shall be recorded. The data shall be analyzed in accordance with paragraph 6.4 and meet the requirements of 3.6.5.3.

4.7.8 Dielectric withstanding voltage. Mated and unmated connectors shall be tested in accordance with MIL-STD-202, Method 301. Test voltages, as shown in Table XII shall be applied between the closest 3 pair of adjacent contacts that were subjected to maintenance aging and between the shell and the 3 contacts closest to the shell that were subjected to maintenance aging (See 3.6.6 and 4.7.4).

*4.7.8.1 Potential to breakdown - variables data. Utilizing mated pairs of connectors, voltage shall be applied to adjacent contacts (See Figure 1a) until breakdown. Test voltage alternating current,

MIL-C-20900 (USAF)

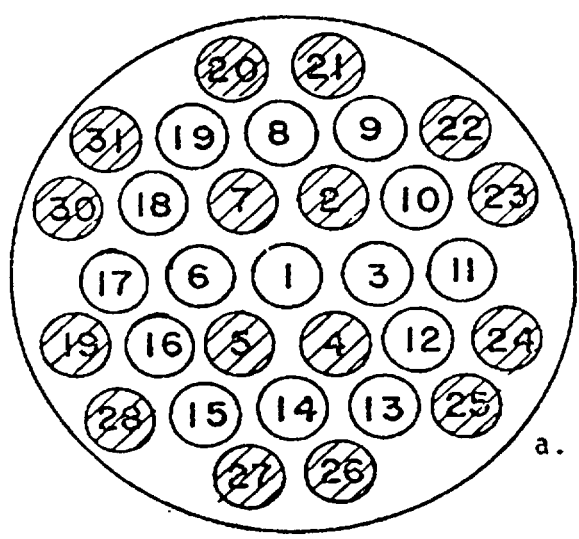

a. ELECTRICAL
8 READINGS

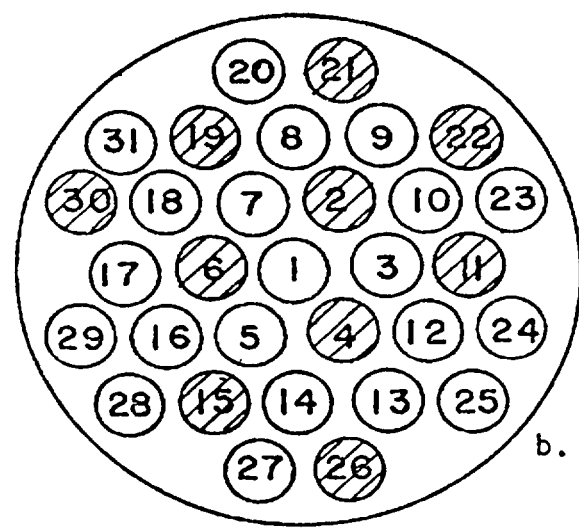

b. MECHANICAL
10 READINGS

FRONT FACE PIN INSERTS
18-31 Inserts

EXAMPLE OF CONTACT LOCATIONS TO BE USED FOR INDEPENDENT
ELECTRICAL AND MECHANICAL READINGS IN CONNECTORS

Figure 1

MIL-C-26500D (USAF)

60 cycle, shall be raised from zero to the breakdown voltage uniformly at a rate not exceeding 100 volts per second. Each test shall be performed on two adjacent contacts. The data shall be analyzed in accordance with 6.4 and meet the requirements of 3.6.6.1.

TABLE XII			
TEST VOLTAGES (AC-RMS)			
Altitude (feet)	Unmated		Mated
	Style S	Style P	
Sea Level	1500	1500	1500
10,000	1250	1250	1250
30,000	750	700	1000
50,000	500	450	1000
70,000	350	275	1000
90,000	250	200	1000
110,000	250	200	1000

4.7.8.2 Dielectric withstanding voltage, altitude. The connectors shall be placed in a suitable chamber at room temperature and tested at 20,000 foot intervals, starting at 10,000 feet and concluding at 110,000 feet. The tests, for both mated and unmated connectors, shall be in accordance with MIL-STD-202, Method 301. Test voltages, as shown in Table XII, shall be applied between the closest 3 pairs of contacts as well as between the shell and the 3 contacts closest to the shell. Exposed wire ends in the chamber shall be widely separated or sealed to reduce corona. The connectors shall meet the requirements of 3.6.6.2 when tested unmated, or 3.6.6.4 when tested mated.

4.7.8.3 Potential to breakdown, mated at altitude - variables data. With the connectors mated, and in a simulated altitude of 110,000 feet, voltage shall be applied in accordance with 4.7.8.1, and the connectors shall meet requirements of 3.6.6.3.

*4.7.9 Fluid immersion (Class R, G, and E). The unmated connectors shall be immersed in the following fluids, for the time indicated:

- a. Half of the samples of Groups IV and V of Table VI, in hydraulic fluid, petroleum base, conforming to MIL-H-5606, for 20 hours.
- b. Half of the samples of Groups IV and V of Table VI,

in aviation lubricating oil, conforming to MIL-L-9236, for 20 hours.

Upon removal from the fluid, the connectors shall be placed in a position to allow the fluid to drain from the mating insert face and remain in free air at room temperature for one hour. The connectors shall then be mated by hand.

4.7.9.1 Fluid immersion (Class F). Connectors in Group IV of Table VI shall be divided equally into seven sub-groups and tested as shown in Table XIII. Each sub-group shall contain connectors wired with the smallest and largest insulation diameter wires as described in 4.4.2. After testing in accordance with Table XIII, the connectors shall be visually (no magnification) inspected for cracks or tears and be mated by hand per 3.6.7.

4.7.10 Durability. The connector assemblies shall be subjected to 200 cycles of mating and unmating for Type T and 500 cycles for Type B. The mating and unmating shall be accomplished in a manner similar to subjection in service. After 200 or 500 cycles, as applicable, the plug and receptacle assemblies shall pass the remaining sequence of tests.

4.7.10.1 Durability - variables data. The connector assemblies shall be subjected to 200 cycles of mating and unmating for Type T and 500 cycles for Type B. The mating and unmating shall be accomplished in a manner similar to subjection in service. After 200 or 500 cycles, as applicable, the plug and receptacle assemblies shall pass the mating and unmating force test of 3.6.2.1.

4.7.11 Contact resistance. Contacts of mated connectors shall be tested in accordance with paragraph entitled "Contact Resistance" of MIL-C-26636, and shall meet the requirements of 3.6.10.

4.7.11.1 Contact resistance - variables data. Contacts of mated connectors shall be tested in accordance with the paragraph entitled "Contact Resistance" of MIL-C-26636. The potential drop shall be recorded for individual contacts. The data shall be analyzed and shall meet the requirements of 3.6.10.1.

*4.7.12 Vibration. The connector assembly shall be mounted as specified herein and be vibrated in accordance with MIL-STD-202, Method 204, Condition D. In addition, the vibration shall be conducted at a low temperature ambient of -55°C and high ambient of 200°C, for Classes R, H, G, and E, and 175°C for Class F. All contacts shall be wired in series, with at least 100 milliamperes of current allowed to flow. A suitable instrument shall be

MIL-C-26500D (USAF)

TABLE XIII		
SAMPLE SUB-GROUP	TEST FLUID SPECIFICATION	TEST PROCEDURE
1	MIL-L-7808	Immerse unmated connectors in fluid at $120^{\circ} \pm 3^{\circ}\text{C}$ for five minutes.
2	MIL-L-23699	Remove connectors and allow to drain for one hour at room temperature. Fluid shall be drained from all recesses. Mate connectors and expose to $175^{\circ} \pm 3^{\circ}\text{C}$ in air circulating oven for 22 hours. Repeat procedure for a total of seven cycles.
3	MIL-H-5606	Same as above except immerse in fluid at 85°C for five minutes and expose mated connectors to $104^{\circ} \pm 3^{\circ}\text{C}$ in an air circulating oven for 22 hours.
4	MIL-J-5624 (Grade JP-5)	Same as for MIL-L-7808 except fluid temperature shall be at room temperature.
5	Glycol	Same as MIL-L-7808 except fluid temperature shall be $65^{\circ} \pm 3^{\circ}\text{C}$ and connectors shall be mated during fluid immersion.
6	Alkaline cleaning solution pH10-12	
7	MIL-H-5606	The unmated connectors shall be immersed in the fluid at room temperature for 20 hours. Remove connectors and allow to drain for 1 hour at room temperature. Fluid shall be drained from all recesses.

MIL-C-26500D (USAF)

employed to monitor the current flow and to indicate any discontinuity of contact or interruption of current flow exceeding one microsecond. Duration of vibration at extreme temperatures shall be 25 percent of the duration specified for the standard temperature condition.

4.7.12.1 Connector mounting. The vibration mounting shall be in accordance with Figure 2. The receptacle shall be mounted on an adapter plate using the connector's normal mounting provisions and suitable hardware. The adapter plate for the receptacle shall be attached to the mounting bracket. The plug shall be mated with the receptacle as in service. No safety wire or supplementary locking device shall be used.

4.7.12.2 Vibration (mated). With no contacts, the connector assembly shall be mounted as specified herein, (no cable clamp required) and vibrated in accordance with MIL-STD-202, Method 204, Condition D. Requirements of 3.6.8 apply, except the electrical requirements are not applicable.

4.7.13 Physical Shock. The wired and mated connectors shall be subjected to a transient deceleration force as specified. The forces shall be produced by securing the connectors to a sufficient mass and dropping the assembly through such a height that when decelerated by resilient impact, a force of 50 gravity units is obtained as outlined in MIL-STD-202, Method 213, Test Condition C. At least one blow shall be applied in each major axis of the connector so that the resultant force tends to disengage the connectors. Receptacles shall be mounted by a method similar to the vibration test on the shock device or carriage. Plugs shall be engaged with the receptacles. The connectors shall be wired in series with at least 100 milliamperes allowed to flow. A suitable instrument shall be employed to monitor the current flow and to indicate any discontinuity of contact or interruption of current flow exceeding one microsecond. The wire bundle or cable shall be clamped to points that move with the connector. A minimum of 8 inches of wire or cable shall be unsupported behind each connector. The connector shall meet the requirements of 3.6.9.

4.7.14 Moisture resistance. The mated and wired connectors shall be subjected to a moisture resistance test in accordance with MIL-STD-202, Method 106, with the following exceptions and details.

- a. Step 7b, vibration not required.
- b. There shall be no drip loops in the wires.

MIL-C-205000 (USAF)

- c. Wires shall be brought out of the chamber through vaportight seals.
- d. There shall be no wire splices in the chamber.
- e. Upon completion of Step 6 of the final cycle, while the connectors are still subjected to high humidity, the insulation resistance shall be measured and requirements of 3.6.12 shall be met.
- f. The Class H receptacles shall not be enclosed for this test, but be blown dry before the insulation resistance measurements.

4.7.15 Corrosion. Wired connectors shall be subjected to a salt spray test in accordance with MIL-STD-202, Method 101, Test Condition B. Immediately after exposure, the exterior surface of the connectors shall be thoroughly washed with tap water. The specimens shall then be dried in a circulating air oven at temperature of $38^{\circ} + 3^{\circ}\text{C}$ for a maximum period of 12 hours. The specimens shall then be removed and inspected to the requirements of 3.6.13.

*4.7.16 Temperature life. The mated connectors shall be subjected to an ambient temperature of $200^{\circ} + 3^{\circ} - 0^{\circ}\text{C}$ for Classes R, H, G, and E and $175^{\circ} + 3^{\circ} - 0^{\circ}\text{C}$ for Class F, as monitored adjacent to connector shells, for a period of 1000 hours. The wired contacts shall carry sufficient current, not exceeding the rated current to maintain a contact temperature of $238^{\circ} + 3^{\circ} - 0^{\circ}\text{C}$ for Classes R, H, G, and E and $200^{\circ} + 3^{\circ} - 0^{\circ}\text{C}$ for Class F. The temperature shall be monitored on a contact closest to the center of the connectors. After exposure to temperature for the time specified, the connectors shall meet requirements of 3.6.14.

4.7.17 Ozone exposure. The unmated connectors shall be subjected to ozone having a concentration from 0.010 to 0.015 percent by volume for 2 hours at room temperature. At the end of the specified period, the samples shall be examined for signs of ozone deterioration in accordance with 3.6.15.

4.7.18 Magnetic permeability. Permeability shall be checked with an instrument conforming to MIL-I-17214. The connectors may be wired or unwired, as convenient, but shall not be carrying current. The connector shall meet the requirements of 3.6.16.

4.7.19 Insert retention. Unmated connectors shall be subjected to axial loads applied separately to insert face and insert rear.

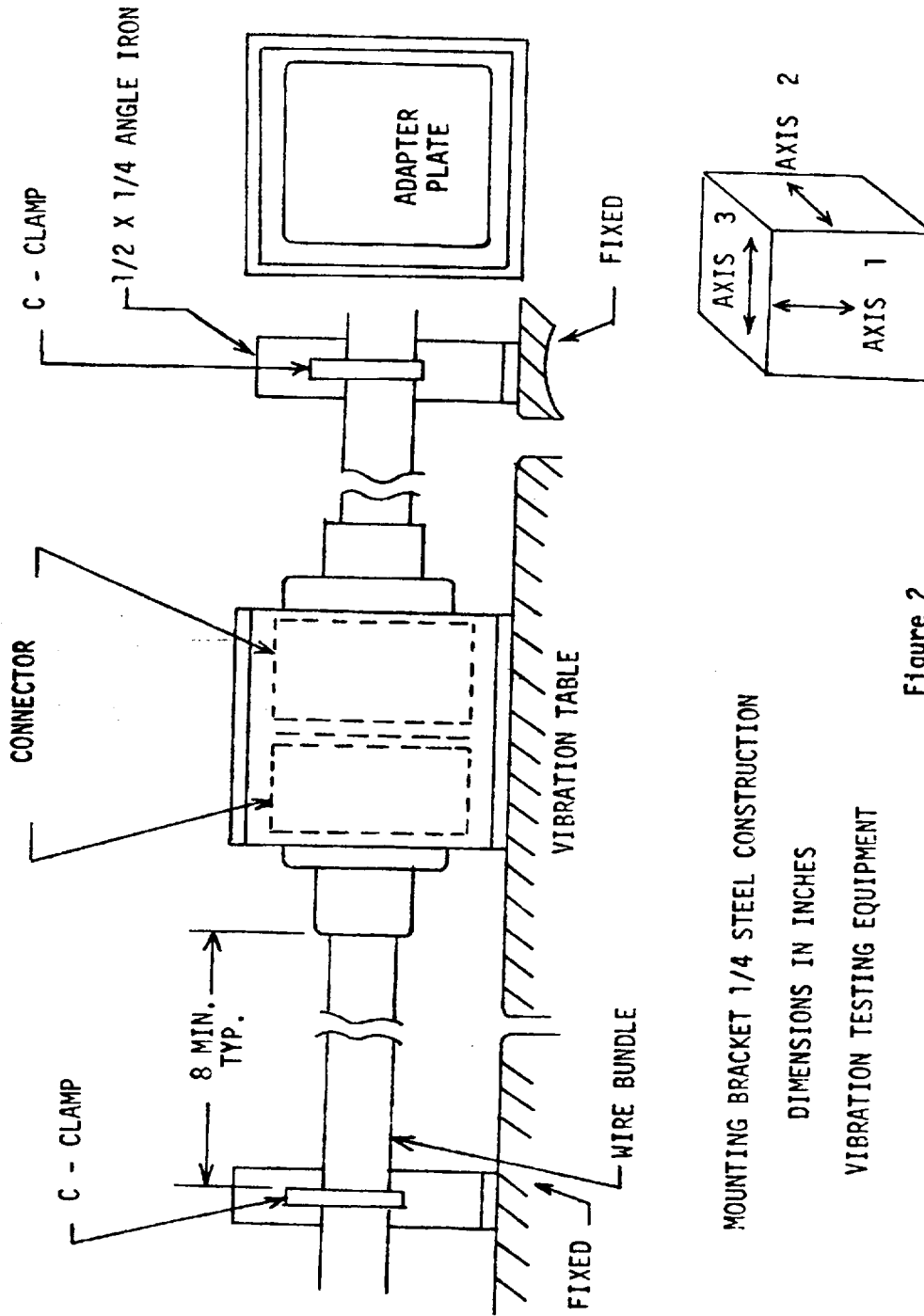

MOUNTING BRACKET 1/4 STEEL CONSTRUCTION
 DIMENSIONS IN INCHES
 VIBRATION TESTING EQUIPMENT

Figure 2

MIL-C 26500D (USAF)

The loading shall be increased gradually at an approximate rate of 10 pound per second until the specified load is reached. The load shall be maintained for the specified time. The load-applying device may be shaped as necessary to reduce the pressure at individual points. The requirements of 3.6.17 shall be met.

*4.7.19.1 Insert retention, Class H. Test specimens shall be mounted in a fixture which simulates mounting in actual service. Such fixture shall accommodate an adapter suitable for connection to a pressure source (air or hydraulic). Pressure shall be gradually applied at a rate such that the specified pressure is uniformly arrived at in a time not to exceed two minutes. Pressure shall be maintained for the specified time, and the requirements of 3.6.17.1 shall apply.

4.7.20 Air leakage. Wired receptacles shall be mounted in a test apparatus, arranged to permit application of a 30 PSI pressure differential across the receptacle. The test shall be performed in both directions separately after 30 minutes of exposure to a temperature of -55°C, and while samples are at the low temperature. The exposed ends of the wires shall not be sealed during the measurement of air leakage; leakage through the unsealed wire insulation shall be included in the air leakage measurements. Means shall be provided for determining leakage of air through the connector, and requirements of 3.6.18 shall apply.

4.7.20.1 Air Leakage, Class H. Receptacles shall be mounted in a test apparatus arranged to permit application of 15 PSI pressure differential across the connector. Prior to test, at least 10%, with a minimum of 3, of the contacts, shall have short wires soldered into normal service positions. Means shall be provided for determining leakage of air or of pressurized gas, containing not less than 10% helium by volume, through the connector while 15 PSI is applied. Requirements of 3.6.18.1 shall apply.

*4.7.21 Altitude immersion. Mated connectors shall be immersed in a container of water at approximately 20°C and placed in a chamber. Wire ends, opposite the connector, shall be terminated within the altitude chamber, exposed to the chamber atmosphere but not submerged. The exposed wire ends shall not be sealed. A quantity of salt, 5% by weight, shall be added to make the water conductive. The chamber pressure shall be reduced to approximately 1 inch of mercury and maintained for 30 minutes. The chamber pressure shall then be returned to atmospheric pressure in not more than one (1) minute. While the connectors are still submerged, insulation resistance measurements shall be made, and the requirements of 3.6.5 shall be met. This shall constitute one cycle. Two additional

MIL-C-26500D (USAF)

environmental cycles shall be run. At the end of the third cycle, the insulation resistance measurements made at the end of the first cycle shall be repeated, and the requirements of 3.6.5 shall be met. A dielectric withstanding test voltage as specified on 3.6.19 shall be applied between the same points as those used for insulation resistance measurements. The voltage shall be applied while the connectors are still submerged, and at atmospheric pressure.

4.7.22 Arc resistance (except Class H). Disc specimens of insert material conforming to specimen designation 2 of MIL-M-14 shall be tested in accordance with FED-STD-406, Test Method 4011, and shall meet the requirements of 3.6.20. The circuit employed is as shown in Figure 3. Details of the test are as follows:

- a. A transformer of 12 kv. minimum voltage shall be used.
- b. Kva rating of the transformer is not specified, but 10 milliamperes (rms) shall be obtainable.
- c. Sufficient external resistance may be added in the leg of the circuit that is not grounded if necessary to obtain the required 10 milliamperes across the electrodes in air (not reading on test specimens).
- d. The cable on the resistance side shall be supported in air.
- e. The floor of chamber shall have a one-inch thick insulating sheet for support of the specimen under test.
- f. A milliammeter shall be placed in the circuit between the ground and the arc electrodes.
- g. The specimens shall be cleaned with a clean cloth dampened with alcohol and dried with a soft, clean, dry cloth before each test.
- h. The arc electrodes shall be cleaned with a soft, clean cloth dampened with alcohol and dried with a soft, clean, dry cloth before each test.
- i. The primary voltage shall be controlled with a variable tap auto transformer.
- j. Relative humidity shall be between 30 and 40%.

MIL-C-26500D (USAF)

- k. The interrupter shall cause an arc to flow 1/4 second and cease 1-3/4 seconds repeatedly during the first minute and to flow 1/4 second and cease 3/4 seconds repeatedly during the second minute.
- l. The electrodes shall consist of 2 steel rods, 0.168 inch diameter, equipped with tungsten wire tips, 0.060 inch in diameter, which have conical points with a 60° included angle. The electrodes shall be mounted to an insulated block at 45° to the vertical and shall be adjusted to give a gap of 0.320 inch. Both electrodes shall be in the same horizontal and vertical planes. The specimen shall meet the requirements of 3.6.20.

4.7.23 Ground resistance. The receptacle of Class G connectors shall be mounted by its normal mounting means to a copper plate of 1/4 inch minimum thickness. With a plug properly mated to the receptacle, a resistance measurement shall be made from a cable clamp screw on the plug to the copper plate, using a milliohmmeter of the four-terminal type. The connectors shall meet the requirements of 3.6.21.

5. PREPARATION FOR DELIVERY

5.1 Preservation and packaging.

*5.1.1 The requirements of Section 5 apply only to direct purchases by or direct shipments to the government or purchases of connectors qualified to this specification by non-government agencies.

5.1.2 Level A. Each plug or receptacle shall be packaged in accordance with Method 1A-8 of MIL-P-116 except that the unit wrapping specified in 5.1.2.1 shall be substituted for the neutral material required as an intimate wrap internal to the barrier material. Contact preservative is not required. Plugs or receptacles having dimensions exceeding 3 inches and weight exceeding 2 pounds shall be further packaged in folding cartons or setup boxes conforming to PPP-B-566 or PPP-B-676.

5.1.2.1 Unit wrapping. Each plug or receptacle shall be wrapped in a transparent bag of equal characteristics to or better than a .003 inch wall thickness polyethylene conforming to L-P-378. The bag shall be sealed to preclude the entry of dust and foreign matter. Materials not conforming to L-P-378 shall have a pH factor equal to that specified in MIL-P-116. Contacts shall be

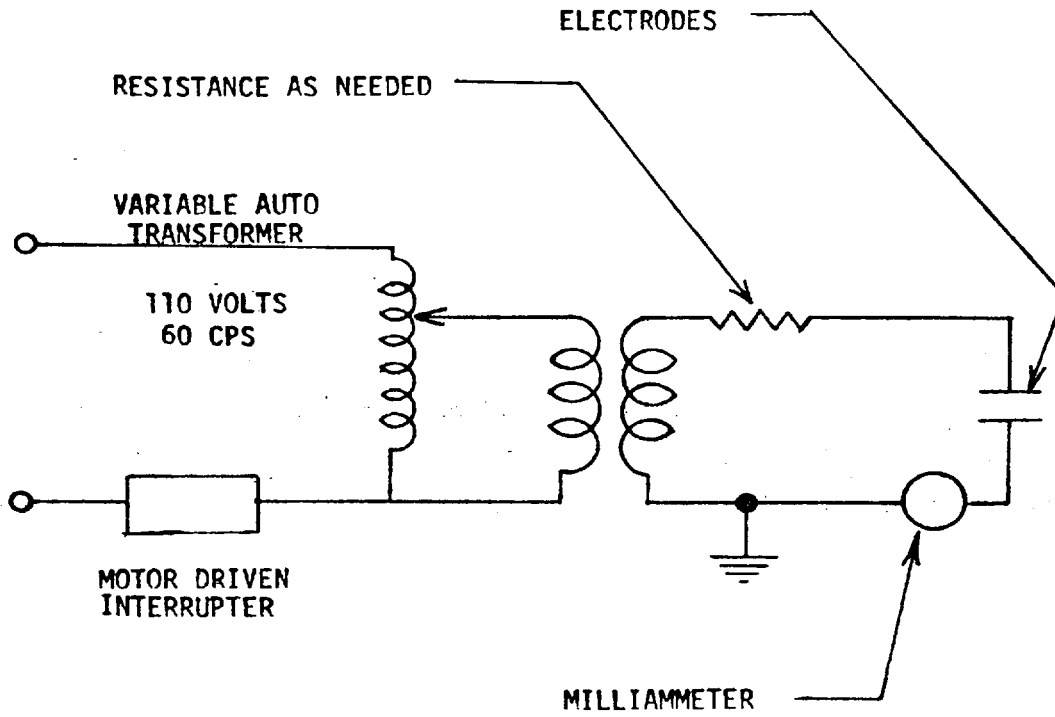

ARC-RESISTANCE TEST CIRCUIT

Figure 3

MIL-C-26500D (USAF)

furnished in a rigid transparent container and supported to restrict movement of the contacts within the container.

- a. Sufficient contacts shall be supplied within the container to complete the insert arrangement, plus a minimum of 2 spares.
- b. Sealing plugs (See 3.2.3) for at least 15% of the contacts in the insert arrangement with a minimum of three, shall be included in the container with the contacts.

5.1.2.2 Unit marking. The following information shall be permanently marked on a low-sulfur-content card in or on the unit wrap container or by a combination of marking on a card or container.

Part Number

Manufacturer's Name

Month and year of manufacture

Purge control symbol

5.1.2.3 Intermediate packaging. Connectors packaged in accordance with 5.1.2 shall be further packaged in quantities of 5 unit packages or multiples thereof in intermediate containers conforming to PPP-B-566, PPP-B-676, or PPP-B-636. The gross weight for intermediate packages shall not exceed 20 pounds, or the weight limitation of the box specification.

5.1.3 Level C. Connectors shall be preserved and packaged in accordance with the manufacturer's commercial practice.

5.2 Packing.

5.2.1 Level A. Connectors, packaged in accordance with Level A or C as specified, shall be packed in wood-cleated fiberboard, nailed wood, wirebound wood, Style 3 for type 2 load, corrugated or solid fiberboard, or wood-cleated plywood (overseas type) boxes conforming to PPP-B-591, PPP-B-621, PPP-B-585, PPP-B-636, or PPP-B-601, respectively. Shipping containers shall have case liners conforming to MIL-L-10547 and appendix hereto. Case liners for boxes conforming to PPP-B-636 may be omitted provided all joints of the boxes are sealed with tape as specified in the appendix of the applicable box specifications. The gross weight of wood boxes shall not exceed 200 pounds; fiberboard boxes shall not exceed the weight limitations of the applicable box specification.

MIL-C-26500D (USAF)

5.2.2 Level B. Connectors, packaged in accordance with Level A or C as specified, shall be packed in wood-created fiberboard, nailed wood, wirebound wood (for type 2 load) corrugated or solid fiberboard, or wood-created plywood (domestic type) boxes conforming to PPP-B-591, PPP-B-621, PPP-B-585, PPP-B-636, or PPP-B-601, respectively. Closures shall be as specified in the applicable box specification, or appendix thereto. Fiberboard boxes shall conform to the special requirements of the applicable box specification. The gross weight of wood boxes shall not exceed 200 pounds; fiberboard boxes shall not exceed the weight limitations of the applicable box specification.

5.2.3 Level C. Connectors, packaged in accordance with Level A or C as specified, shall be packed in containers in a manner to insure safe delivery and acceptance at destination. Containers shall comply with the Consolidated Freight Classification Rules or other carrier regulations applicable to the mode of transportation.

5.3 Marking of shipments. Each unit and intermediate package and shipping container shall be marked in accordance with MIL-STD-129.

6.0 NOTES

6.1 Intended use. The connectors covered by this specification are intended for use in electrical control and power circuits of ground, rocket, missile, aircraft and space environments.

6.2 Ordering data. Procurement documents should specify the following:

- a. Procurement of items to this specification will be only from sources that, prior to closing data of bids, have received qualification of the product within terms of the Armed Services Procurement Regulations, ASPR, Paragraph 1-1101 through 1-111 (See Paragraph 6.3).
- b. Title, number, and date of this specification.
- c. The part number in accordance with the applicable military standards.
- d. Accessories.
- e. Levels of preservation, packaging, packing, and applicable marking.

MIL-C-26500D (USAF)

- f. Special handling, if applicable.

6.3 Qualification. With respect to products requiring qualification, awards will be made only for such products as have, prior to the time set for opening bids, been tested and approved for inclusion in the applicable Qualified Product List whether or not such products have actually been so listed by that date. The attention of suppliers is called to this requirement, and manufacturers are urged to arrange to have the products that they propose to offer to the Federal Government tested for qualification in order that they may be eligible to be awarded contracts or orders for the products covered by this specification.

The activity responsible for the Qualified Product List is

Rome Air Development Center
ATTN: RCRC
Griffiss AFB, NY 13440

6.4 Data handling.

6.4.1 Variables data reduction. Reduction of variables data shall be accomplished by:

- a. Determining if data is normal or non-normal through the application of the Chi-Square or the Kolmogorov-Smirnov Test.
- b. If the data is normal, proceed to:
 - (1) Compute the data mean (average) by

$$\bar{X} = \frac{\sum_{i=1}^N X_i}{N}, \text{ where}$$

\bar{X} is the mean or average of the data
 X_i is the value of an individual measurement
 N is the total number of measurements.

MIL-C-26500D (USAF)

- (2) Compute the standard deviation as:

$$s = \left(\frac{\sum_{i=1}^N X_i^2}{N} - \bar{X}^2 \right)^{\frac{1}{2}} \text{ where}$$

S is the standard deviation, and other symbols are as in (1).

- (3) Consult Table XIV for the proper multiplying factor (k) and compute:
- (a) The upper limit as $L_U = \bar{X} + ks$ where a maximum requirement is given in this specification.
 - (b) The lower limit as $L_L = \bar{X} - ks$ where a minimum requirement is given in this specification.
 - (c) Both limits where requirements of this specification establish both a minimum and maximum value.

c. If the data is not normal, proceed to:

- (1) Normalize the distribution by the application of statistically sound methods such as:
 - (a) Taking the logarithm of the data.
 - (b) Taking reciprocals of the data.
- (2) After normalizing by transformation, reduce data per the above and retransform for comparison to specification limits.
- (3) Solve directly by plotting on Weibull Paper.

*6.5 The margins of this specification are marked with an asterisk to indicate where changes (additions, modifications, corrections deletions) from the previous issue were made. This has been done as a convenience only and the government assumes no liability whatsoever for any inaccuracies in these notations. Bidders and contractors are cautioned to evaluate the requirements of this

MIL-C-26500D (USAF)

TABLE XIV							
K FACTOR FOR TWO SIDED LIMITS							
N	K	N	K	N	K	N	K
2	48.430	51	3.119	100	2.934	220	2.803
3	12.861	52	3.112	101	2.932	225	2.800
4	8.299	53	3.106	102	2.930	230	2.798
5	6.634	54	3.100	104	2.926	235	2.795
6	5.775	55	3.094	106	2.922	240	2.792
7	5.248	56	3.088	108	2.918	245	2.790
8	4.891	57	3.082	110	2.915	250	2.788
9	4.631	58	3.076	112	2.911	255	2.785
10	4.433	59	3.071	114	2.908	260	2.783
11	4.277	60	3.066	116	2.904	265	2.781
12	4.150	61	3.061	118	2.901	270	2.779
13	4.044	62	3.056	120	2.898	275	2.777
14	3.955	63	3.051	122	2.895	280	2.775
15	3.878	64	3.046	124	2.892	285	2.773
16	3.812	65	3.042	126	2.889	290	2.771
17	3.754	66	3.037	128	2.886	295	2.769
18	3.702	67	3.033	130	2.883	300	2.767
19	3.656	68	3.029	132	2.880	310	2.764
20	3.615	69	3.025	134	2.878	320	2.760
21	3.577	70	3.021	136	2.875	330	2.757
22	3.543	71	3.017	138	2.873	340	2.754
23	3.512	72	3.013	140	2.870	350	2.752
24	3.483	73	3.009	142	2.868	360	2.749
25	3.457	74	3.006	144	2.865	370	2.746
26	3.432	75	3.002	146	2.863	380	2.744
27	3.409	76	2.999	148	2.861	390	2.742
28	3.388	77	2.996	150	2.859	400	2.739
29	3.368	78	2.992	152	2.856	425	2.734
30	3.350	79	2.989	154	2.854	450	2.729
31	3.332	80	2.986	156	2.852	475	2.725
32	3.316	81	2.983	158	2.850	500	2.721
33	3.300	82	2.980	160	2.848	525	2.717
34	3.286	83	2.977	162	2.846	550	2.713
35	3.272	84	2.974	164	2.844	575	2.710
36	3.258	85	2.971	166	2.843	600	2.707
37	3.246	86	2.968	168	2.841	625	2.704
38	3.239	87	2.966	170	2.839	650	2.702
39	3.226	88	2.963	172	2.837	675	2.699
40	3.213	89	2.960	174	2.835	700	2.697
41	3.202	90	2.958	176	2.834	725	2.694
42	3.192	91	2.955	178	2.832	750	2.692
43	3.183	92	2.953	180	2.831	800	2.688
44	3.173	93	2.950	185	2.827	850	2.685
45	3.165	94	2.948	190	2.823	900	2.682
46	3.156	95	2.945	195	2.819	950	2.679
47	3.148	96	2.943	200	2.816	1000	2.676
48	3.140	97	2.941	205	2.812	∞	2.576
49	3.133	98	2.939	210	2.809		
50	3.126	99	2.936	215	2.806		

*95% Confidence Level - 99% of Design Universe

*This confidence level holds only where data is truly normal. Departure from a normal distribution will lower confidence somewhat. The exact amount of such a reduction is not readily obtainable.

MIL-C-26500D (USAF)

document based on the entire content irrespective of the marginal notations and relationship to the last previous issue.

Reviewers:
Air Force - 11, 80

Preparing activity:
Air Force - 17

Project No 5935-F552

This standard has been approved by the Department of the Army, Department of the Navy, Department of the Air Force, and the Department of Defense. All other military activities are required to supply this standard where applicable.

NOTE: When Government drawings, specifications, or other data are used for any purpose other than in connection with a definitely related Government procurement operation, the United States Government hereby makes no responsibility, nor any obligation whatsoever, and the fact that the Government may have furnished, furnished, or is now furnishing, the said drawings, specifications, or other data is not to be regarded by implication or otherwise as in any manner licensing the holder or any other person or corporation, or conveying any rights or permission to manufacturer, use, or sell any patented invention that may in any way be related thereto.

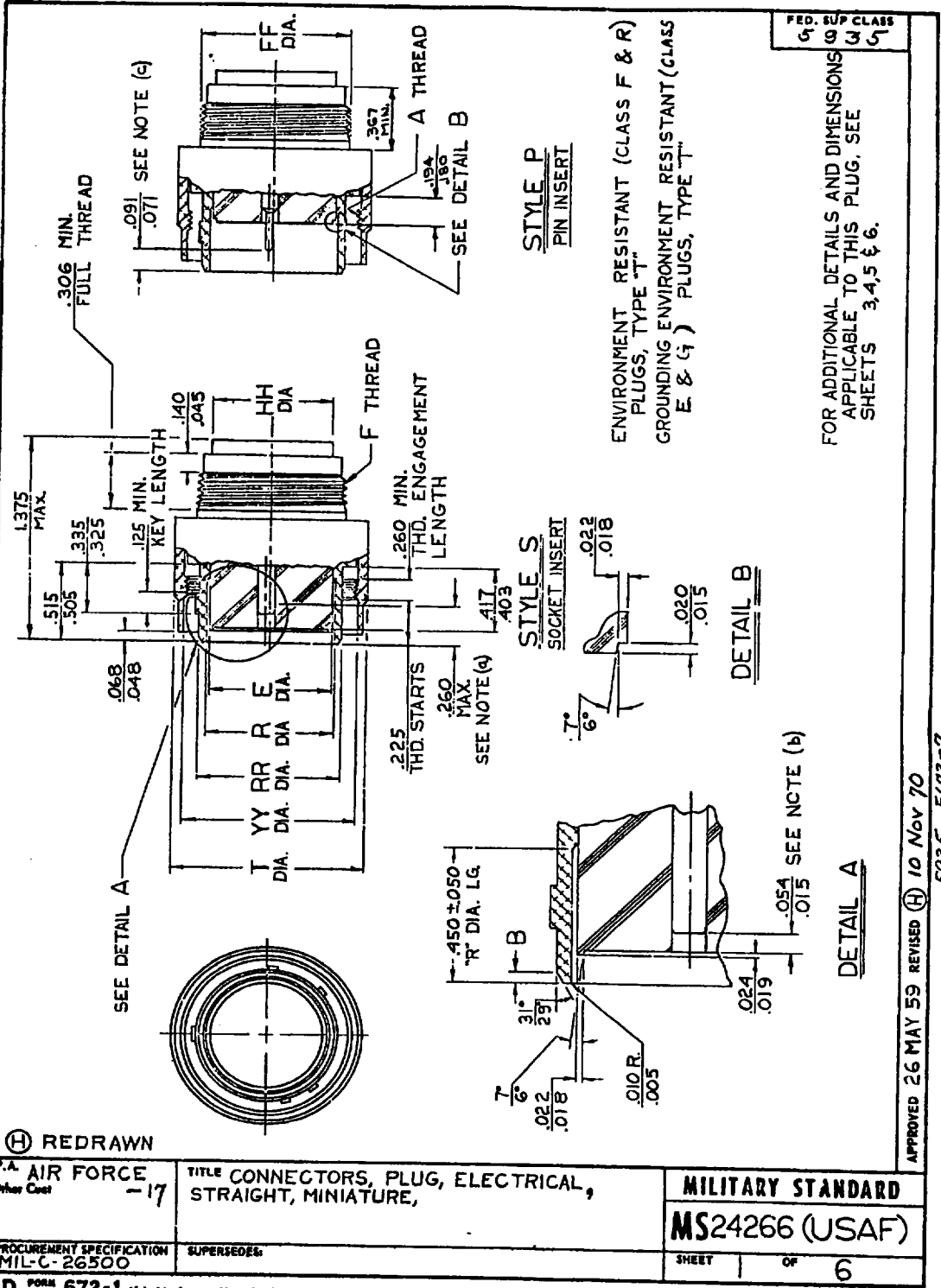

Ⓜ REDRAWN

P.A. AIR FORCE
Other Code -17

TITLE CONNECTORS, PLUG, ELECTRICAL,
STRAIGHT, MINIATURE,

MILITARY STANDARD

PROCUREMENT SPECIFICATION
MIL-C-26500

SUPERSEDES:

MS24266 (USAF)

SHEET OF 6

DD FORM 672-1 (Limited circulation)

PREVIOUS EDITIONS OF THIS FORM ARE OBSOLETE.

FOR ADDITIONAL DETAILS AND DIMENSIONS APPLICABLE TO THIS PLUG, SEE SHEETS 3, 4, 5 & 6.

DETAIL B

DETAIL A

APPROVED 26 MAY 59 REVISED 10 Nov 70
5935-F673-7

This standard has been approved by the Department of the Air Force and is mandatory for use by the activity. All other military activities are required to employ this standard where suitable.

NOTICE—When Government drawings, specifications, or other data are used for any purpose other than in connection with a definitely related Government procurement operation, the United States Government thereby incurs no responsibility, nor any obligation whatsoever; and the fact that the Government may have furnished, furnished, or in any way supplied the said drawings, specifications, or other data is not to be regarded by implication or otherwise as in any manner endorsing the holder or any other person or corporation, or conveying any rights or permission to manufacturer, use, or sell any patented invention that may in any way be related thereto.

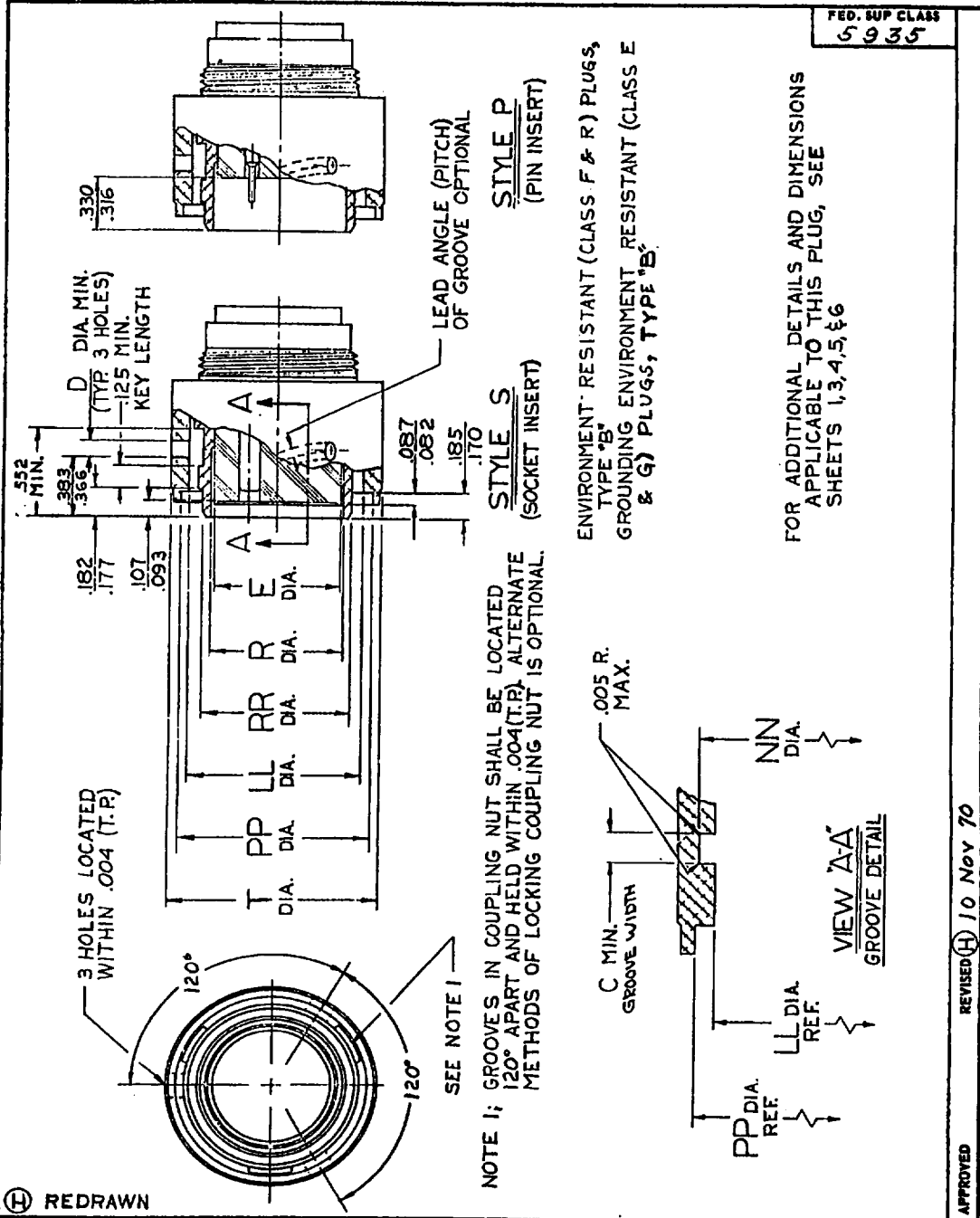

Ⓜ REDRAWN

P.A. AIR FORCE Other Code -17	TITLE CONNECTORS, PLUG, ELECTRICAL, STRAIGHT, MINIATURE	MILITARY STANDARD
PROCUREMENT SPECIFICATION MIL-C-26500	SUPERSEDES:	MS24266 (USAF)
DD FORM 672-1 (United coordination)		SHEET 2 OF 6

NOTE 1; GROOVES IN COUPLING NUT SHALL BE LOCATED 120° APART AND HELD WITHIN .004(T.P.) ALTERNATE METHODS OF LOCKING COUPLING NUT IS OPTIONAL.

STYLE S (SOCKET INSERT)

STYLE P (PIN INSERT)

ENVIRONMENT RESISTANT (CLASS F & R) PLUGS, TYPE "B"
GROUNDING ENVIRONMENT RESISTANT (CLASS E & G) PLUGS, TYPE "B"

FOR ADDITIONAL DETAILS AND DIMENSIONS APPLICABLE TO THIS PLUG, SEE SHEETS 1,3,4,5,6&6

FED. SUP CLASS 5935

APPROVED REVISED (H) 10 Nov 70

FED. SUP CLASS
5935

NOTE—When Government drawings, specifications, or other data are used for any purpose other than in connection with a definitely related Government procurement operation, the United States Government hereby accepts no responsibility for any obligation whatsoever; and the fact that the Government may have furnished, published, or in any way supplied the said drawings, specifications, or other data is not to be regarded by implication or otherwise as in any manner limiting the holder or any other person or corporation, or conveying any right or permission to manufacture, use, or sell any patented invention (if any) in any way be related thereto.

This standard has been approved by the Department of the Army, Department of the Navy, and is mandatory for use by their activity. All other military activities are required to employ this standard where applicable.

SHELL SIZE	TT +0.000 -0.003	RR +0.000 -0.005	SS ±0.003 KEY WIDTH	U ±.003 KEY WIDTH
8	.234	.424	.084	.042
10	.285	.526	.084	.052
12	.370	.696	.084	.052
14	.405	.765	.084	.052
16	.468	.892	.115	.052
18	.521	.993	.115	.052
20	.583	1.123	.115	.052
22	.646	1.248	.115	.052
24	.708	1.373	.115	.052

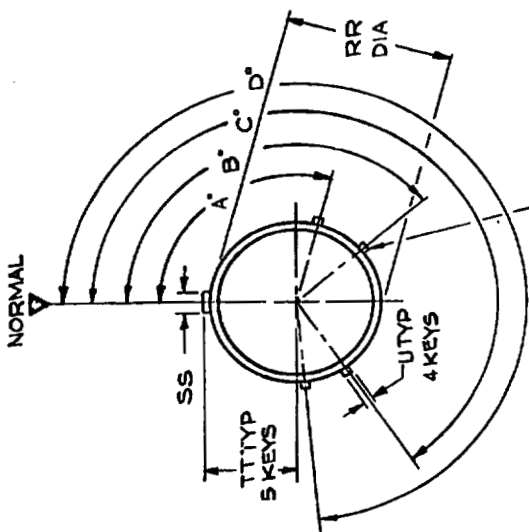

ALTERNATE SHELL KEY POSITIONS FOR PLUG CONNECTORS

POSITION	SIZE 10											
	A'	B'	C'	D'	A	B	C	D	A'	B'	C'	D'
NORMAL	105	140	215	265	105	140	215	265	105	140	215	265
6	102	132	248	320	102	132	248	320	18	149	192	259
7	80	118	230	312	80	118	230	312	92	152	222	342
8	35	140	205	275	35	140	205	275	84	152	204	334
9	64	155	234	304	64	155	234	304	24	135	199	240
10					25	115	220	270	98	152	268	336

(H) REDRAWN

P.A. AIR FORCE Other Cust -17	TITLE CONNECTORS, PLUG, ELECTRICAL, STRAIGHT, MINIATURE	MILITARY STANDARD MS24266(USAF)
PROCUREMENT SPECIFICATION MIL-C-26500	SUPERSEDES:	SHEET 3 OF 6

DD FORM 1, SEP 57 672-1 (Limited coordination)

PREVIOUS EDITIONS OF THIS FORM ARE OBSOLETE.

APPROVED REVISED (H) 10 Nov 70

FED. SUP CLASS
5935

This standard has been approved by the Department of the Army. It is mandatory for use by all military activities. All other military activities are required to comply with standards where suitable.

NOTICE—When Government drawings, specifications, or other data are used for any purpose other than in connection with a definitely related Government procurement operation, the United States Government, its agencies, its employees, or any other person or organization, is not to be regarded as endorsing, recommending, or certifying the use of such data, nor is it to be regarded as making any warranty, expressed or implied, or assuming any liability in connection with the use of such data. The Government makes no warranty, expressed or implied, or assuming any liability in connection with the use of such data.

(H) REDRAWN

P.A. AIR FORCE
Other Case 117

TITLE CONNECTORS, PLUG, ELECTRICAL,
STRAIGHT, MINIATURE,

MILITARY STANDARD

PROCUREMENT SPECIFICATION
MIL-C-26500

SUPERSEDES:

MS24266 (USAF)

SHEET 4 OF 6

DD FORM 672-1 (Limited coordination)

PREVIOUS EDITIONS OF THIS FORM ARE OBSOLETE.

SHELL SIZE	A UNEF-2B COUPLING THREAD	E MAX. INSERT DIA.	F UNEF-2A ACCE SS. THREAD	FF MAX. DIA.	HH MAX. GROMMET DIA.	LL DIA. +0.005 -0.000	NN MIN. DIA.	PP MIN. DIA.	R MIN. DIA.	T MAX.Q.D. COUPLING NUT	YY MIN. DIA.	FOR INSERT ARRANGEMENT SEE DWG.
8	7/16-24	.312	7/16-28	.437	.328	.540	.632	.632	.352	.776	.583	MS27561
10	1/16-24	.388	9/16-24	.562	.420	.662	.760	.760	.428	.906	.707	MS24260
12	7/8-20	.553	3/4-20	.750	.580	.832	.930	.930	.598	1.078	.895	MS24260
14	15/16-20	.627	13/16-20	.812	.664	.901	.999	.999	.667	1.141	.957	MS24260
16	1 1/16-18	.754	1 1/16-20	.938	.769	1.028	1.126	1.126	.794	1.266	1.084	MS24261
18	1 1/16-18	.860	1 1/16-18	1.062	.902	1.134	1.232	1.232	.900	1.375	1.203	MS24262
20	1 5/16-18	.985	1 7/16-18	1.182	1.033	1.261	1.357	1.357	1.025	1.510	1.334	MS27561
22	1 7/16-18	1.110	1 7/16-18	1.312	1.152	1.384	1.482	1.482	1.150	1.625	1.459	MS24263
24	1 9/16-18	1.235	1 7/16-18	1.432	1.282	1.511	1.607	1.607	1.275	1.760	1.594	MS27561

SHELL SIZE	B	C MIN.	D MIN. DIA.
8	.025	.079	.079
10	.031	.084	.084
12	.031	.094	.094
14	.031	.094	.094
16	.031	.094	.094
18	.031	.094	.094
20	.031	.094	.094
22	.031	.094	.094
24	.031	.094	.094

APPROVED REVISED 10 Nov 70

FED. SUP CLASS
5935

NOTICE—When Government drawings, specifications, or other data are used for any purpose other than in connection with a definitely related Government procurement operation, the United States Government's liability is hereby disclaimed. The fact that the Government is shown on any drawing, specification, or other data, or in any supply list, does not constitute an acknowledgment of the Government's responsibility therefor, nor does it constitute an authority for the Government to assume any liability for the use of drawings, specifications, or other data, or in any supply list, for any purpose other than that for which it was prepared. The fact that the Government is shown on any drawing, specification, or other data, or in any supply list, does not constitute an acknowledgment of the Government's responsibility therefor, nor does it constitute an authority for the Government to assume any liability for the use of drawings, specifications, or other data, or in any supply list, for any purpose other than that for which it was prepared.

ALL DIAMETERS TO BE CONCENTRIC WITH EACH OTHER WITHIN .015 T.I.R.
 ALL DIAMETERS IN THE SAME PLANE TO BE CONCENTRIC WITH EACH OTHER WITHIN .004 T.I.R.
 CONTACTS TO BE IN ACCORDANCE WITH SPEC. MIL-C-26636.
 TRUE POSITION (T.P) TOLERANCE SPECIFIED ARE FOR MAXIMUM MATERIAL CONDITIONS (M.M.C.)

(a) DISTANCE BETWEEN END OF SHELL AND THE POINT AT WHICH A GAGE PIN, HAVING THE SAME BASIC DIAMETER AS THE MATING CONTACT AND A SQUARE FACE, ENGAGES SOCKET CONTACT SPRING.

(b) DIMENSIONS ON PIN AND SOCKET CONTACT LOCATIONS AND INSERT FACES APPLY WHEN CONTACTS ARE PLACED IN INSERTS FOR INSPECTION OR APPLICATION.

(c) .071 MAY REDUCE TO .056 MIN. UNDER PRESSURES CAUSED BY MOLDED CABLE ASSEMBLIES OR SHARP CABLE BENDS.

FOR ACCESSORIES USED WITH THIS CONNECTOR SEE PARAGRAPH 32.7 OF PROCUREMENT SPECIFICATION,
 DIMENSIONS IN INCHES, UNLESS OTHERWISE SPECIFIED TOLERANCES - DECIMALS - ±.005

REFERENCED DOCUMENTS SHALL BE THE ISSUE IN EFFECT ON DATE OF INVITATIONS FOR BID.
 THIS STANDARD TAKES PRECEDENCE OVER DOCUMENTS REFERENCED HEREIN.
 USE TOOL MS24256A TO ASSEMBLE CONTACTS INTO THIS CONNECTOR
 USE TOOL MS24256R TO REMOVE CONTACTS FROM THIS CONNECTOR

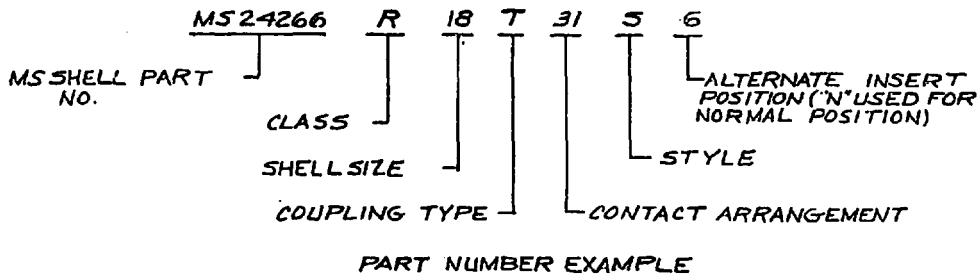

This standard has been approved by the Department of the Army. It is mandatory for use by that activity. All other military activities are required to employ this standard where applicable.

(H) REDRAWN

P.A. AIR FORCE Other Cust	TITLE CONNECTORS, PLUG, ELECTRICAL, STRAIGHT, MINIATURE	MILITARY STANDARD MS24266(USAF)
PROCUREMENT SPECIFICATION MIL-C-26500	SUPERSEDES:	SHEET 5 OF 6

DD FORM 1 SEP 57 672-1 (limited coordination)

PREVIOUS EDITIONS OF THIS FORM ARE OBSOLETE.

APPROVED
REVISED 10 NOV 70

FED. SUP CLASS
5935

NOTICE—When Government drawings, specifications, or other data are used for any purpose other than in connection with a definitely related Government procurement operation, the United States Government hereby means no responsibility, nor any obligation whatsoever; and the fact that the Government may have furnished, furnished, or in any way supplied the said drawings, specifications, or other data is not to be regarded by implication or otherwise as in any manner increasing the liability of any other person or corporation, or conveying any right or permission to manufacture, use, or sell any patented invention that may in any way be related thereto.

WEIGHT CHART					
MAXIMUM CONNECTOR WEIGHT IN LBS.					
PIN INSERT			SOCKET INSERT		
M5 PART NUMBER	LESS WITH CONTACTS	WITH CONTACTS	M5 PART NUMBER	LESS WITH CONTACTS	WITH CONTACTS
MS24266R8T2PN	.028	.030	MS24266R8T2SN	.029	.031
10T2PN	.040	.042	10T2SN	.041	.043
10T5PN	.039	.043	10T5SN	.040	.044
10T20PN	.040	.044	10T20SN	.041	.045
12T3PN	.055	.060	12T3SN	.057	.062
12T12PN	.053	.063	12T12SN	.054	.064
14T3PN	.059	.069	14T3SN	.061	.070
14T4PN	.059	.074	14T4SN	.061	.076
14T7PN	.059	.072	14T7SN	.061	.072
14T12PN	.059	.072	14T12SN	.061	.074
14T15PN	.059	.073	14T15SN	.061	.074
16T10PN	.072	.090	16T10SN	.071	.089
16T24PN	.071	.091	16T24SN	.074	.094
18T8PN	.081	.110	18T8SN	.084	.112
18T11PN	.078	.102	18T11SN	.082	.105
18T14PN	.078	.103	18T14SN	.082	.107
18T31PN	.078	.104	18T31SN	.082	.107
20T16PN	.098	.126	20T16SN	.101	.129
20T25PN	.095	.133	20T25SN	.099	.136
20T28PN	.097	.132	20T28SN	.099	.133
20T33PN	.097	.132	20T33SN	.099	.133
20T41PN	.097	.131	20T41SN	.099	.133
22T12PN	.110	.153	22T12SN	.117	.156
22T19PN	.110	.154	22T19SN	.117	.150
22T32PN	.110	.153	22T32SN	.117	.160
22T55PN	.106	.153	22T55SN	.112	.157
24T43PN	.128	.184	24T43SN	.134	.188
24T57PN	.128	.181	24T57SN	.133	.185
MS24266R24T61PN	.125	.176	MS24266R24T61SN	.131	.181

THREADED CONNECTORS CLASSES EFG & R

This standard has been approved by the Department of Defense. It is mandatory for use by all military organizations and is required to comply with standards where applicable.

(H) REDRAWN			
P.A. AIR FORCE Other Code -17	TITLE CONNECTORS, PLUG, ELECTRICAL, STRAIGHT, MINIATURE	MILITARY STANDARD	
PROCUREMENT SPECIFICATION MIL-C-26500	SUPERSEDES:	MS24266(USAF)	
		SHEET 6 OF 6	

DD FORM 672-1 (Limited coordination) PREVIOUS EDITIONS OF THIS FORM ARE OBSOLETE.
☆ U. S. GOVERNMENT PRINTING OFFICE: 1971-433-694/3754

REVISED 10 Nov 70
APPROVED

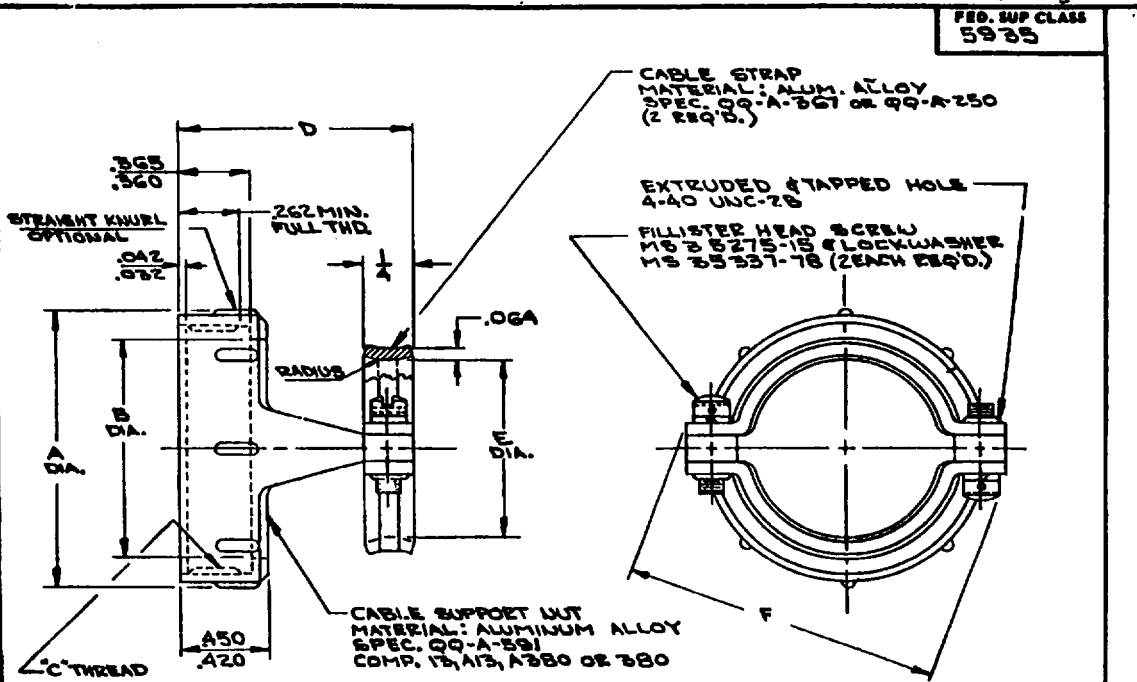

MS PART NUMBER	FOR SHELL SIZE	A MAX. DIA.	B HOLE DIA.	C UNEF-28 COUPLING THREAD	D ±.015	E ±.015 DIA.	F MAX.
MS27291-1	10	.731	.459	9/16-24	.935	.270	.914
MS27291-2	12	.919	.636	3/4-20	.935	.400	1.026
MS27291-3	14	.981	.698	13/16-20	1.170	.460	1.090
MS27291-4	16	1.106	.823	15/16-20	1.170	.610	1.250
MS27291-5	18	1.231	.941	1 1/4-18	1.170	.690	1.358
MS27291-6	22	1.481	1.191	1 3/4-18	1.170	.940	1.604
MS27291-13	8	.582	.358	7/16-28	.935	.180	.785
MS27291-14	20	1.356	1.066	1 1/4-18	1.170	.830	1.496
MS27291-15	24	1.606	1.316	1 3/4-18	1.170	1.040	1.740

NOTES:

1. FINISH- ANODIZE PER SPEC. MIL-A-8625 OR SUITABLE HARD ANODIZING PROCESS TO MEET THE PERFORMANCE REQUIREMENTS OF MIL-C-26500 AND MIL-C-38300.
2. ALL THREADS IN ACCORDANCE WITH SPECIFICATION MIL-S-7742.
3. DIMENSIONS IN INCHES, UNLESS OTHERWISE SPECIFIED, TOLERANCES: DECIMALS ±.003, FRACTIONS ± 1/64, ANGLES ± 2°.
4. REFERENCED DOCUMENTS SHALL BE OF THE ISSUE IN EFFECT ON DATE OF INVITATIONS FOR BIDS THESE PARTS ARE INTENDED FOR USE WITH MINIATURE ELECTRICAL CONNECTORS PER SPECIFICATION MIL-C-26500 AND MIL-C-38300.
5. FOR BUSHING CABLE ADAPTER SEE MS-27290.
6. REMOVE ALL BURRS AND SHARP EDGES.

REDRAWN

This standard has been approved by the Department of the Air Force and is mandatory for use by that activity. All other military activities are invited to employ this standard where feasible.

P.A. AIR FORCE 17 Other Cost	TITLE SUPPORT, CABLE, ELECTRICAL CONNECTOR	MILITARY STANDARD MS 27291(USAF)
PROCUREMENT SPECIFICATION NONE	SUPERSEDES.	SHEET 1 OF 1

DD FORM 672-1 (limited coordination)

EDITION OF 1 SEP 1964, RELEASSED

☆ U. S. GOVERNMENT PRINTING OFFICE: 1971-433-694/5034

APPROVED 15 AUG 63 REVISED 17 DEC 63 4 Jan 71 5935-F681

APPENDIX IV

Sample Photographs

Photograph A1: DC-10 Sample 6 Connectors



Photograph A2: DC-10 Sample 8 Connectors



Photograph A3: White 747 Sample 1 Connectors

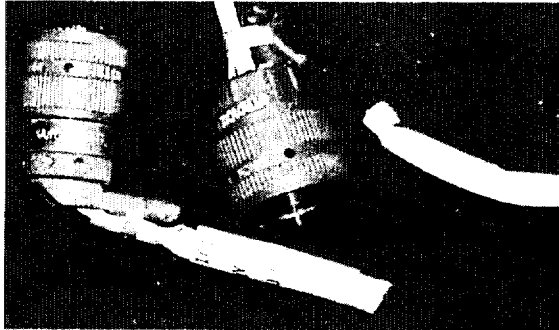

Photograph A4: White 747 Sample 4 Connectors

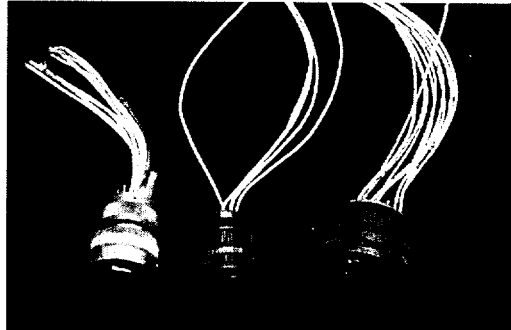

Photograph A5: White 747 Sample 5 Connectors

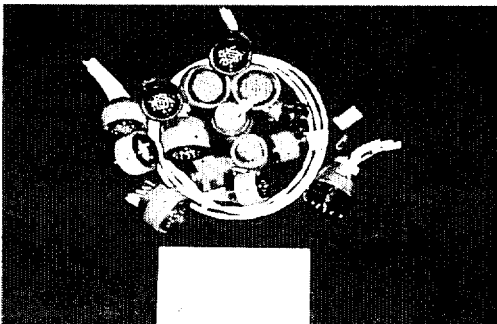

Photograph A6: European 747 Sample 1 Connectors

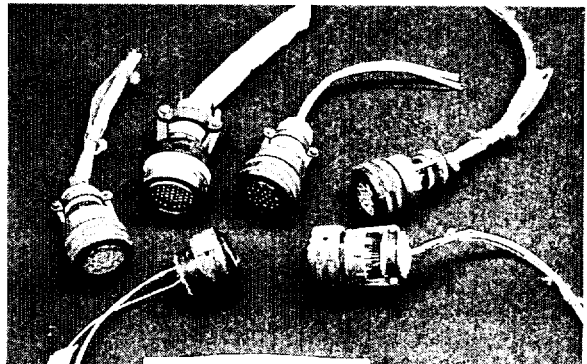

APPENDIX V

Photographs of Sample Problems

Photo B1: DC-10 Sample 8 gouging of wire

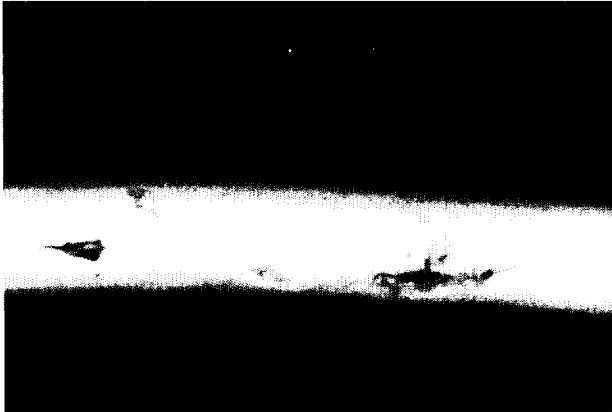

Photo B2: White 747 Sample 5 mangled area of wire with dielectric failure



Photo B3: Dirt and grime DC10 Sample 8 wire

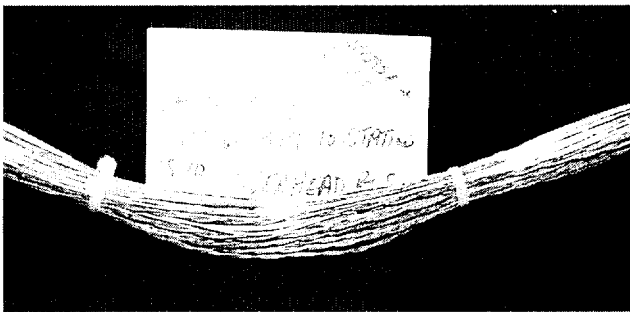

Photo B4: DC-10 connectors with brown film

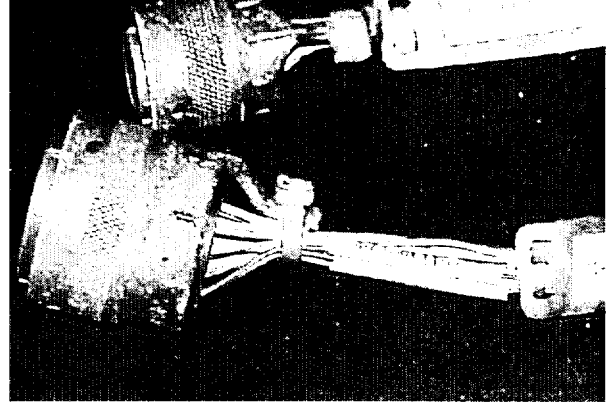

Photo B5: DC-10 Sample 8 Connector with Corrosion

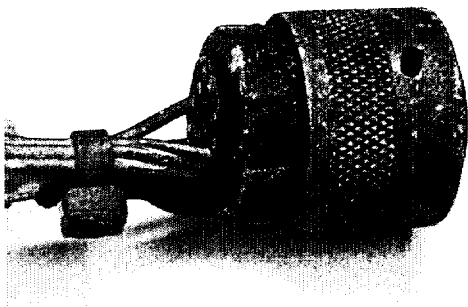

Photo B6: DC10 Sample 6 Connector Grommet deformation and surface crumbling



Photo B7: White 747 Sample 5 Connector with small number of wires (1 wire), no backshell and no support for wire

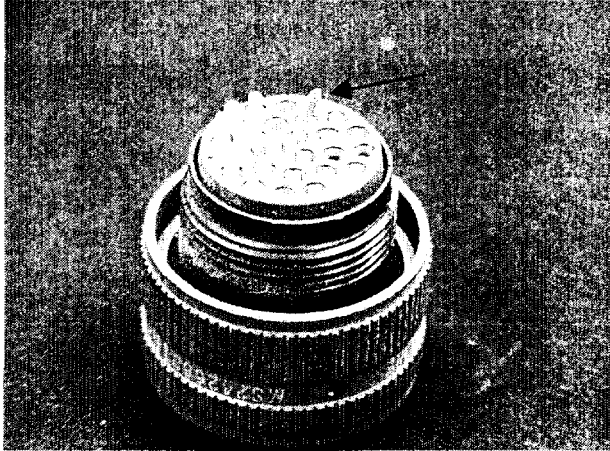

Photo B8: European 747 S1 connector with small number of wires, and additional support for wires



Photo B9: White 747 Sample 4 with sealing plugs in place

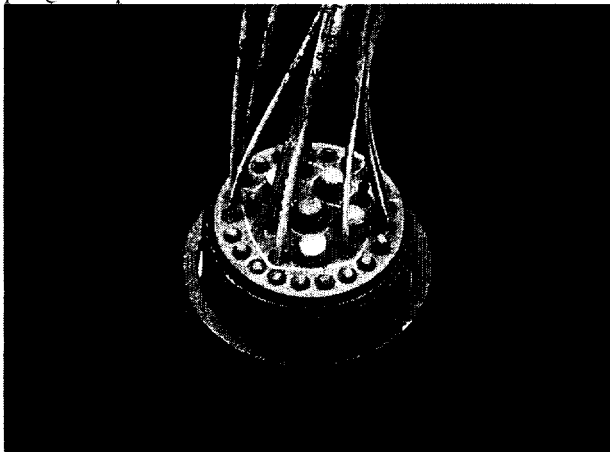

Photo B10: White 747 Sample 1 Connector tape degradation, sticky residue



Photo B11: Fine metallic filing contamination in grommet

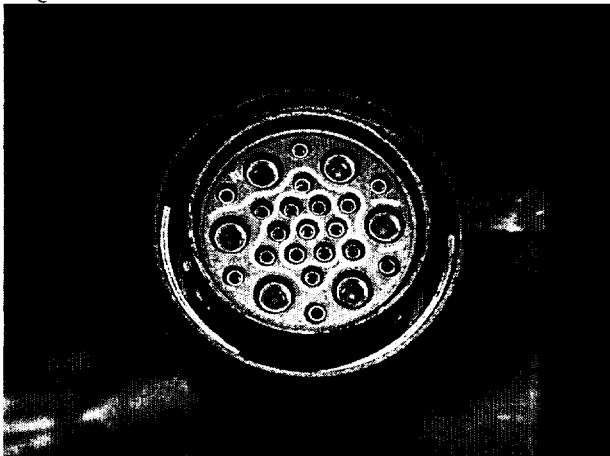

Photo B12: DC-10 Sample 8 dielectric failure on untested wire

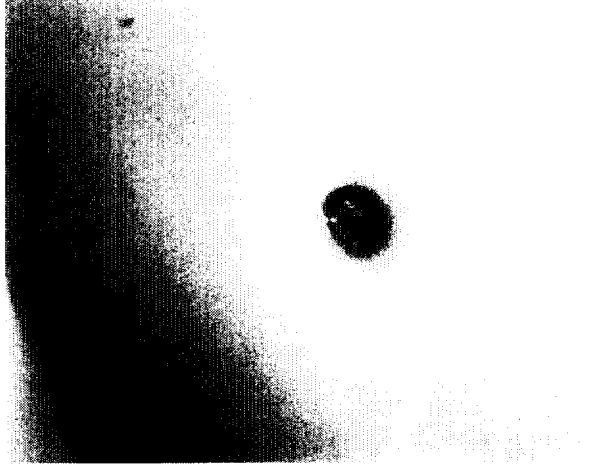

Photo B13: DC-10 Sample 4 Cold Bend Failure

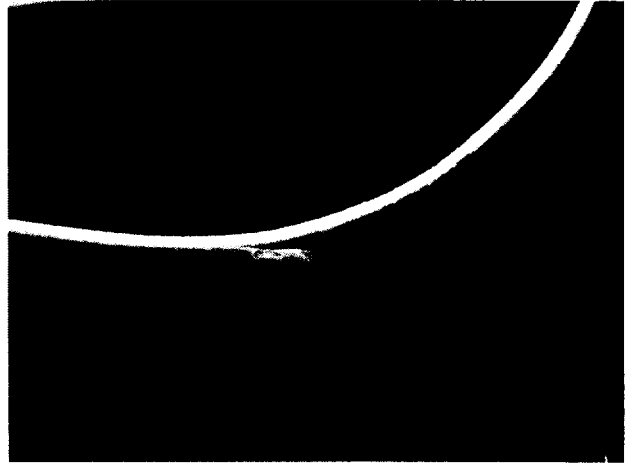

Photo B14: White 747 Sample 5 low temperature cold bend failure



Photo B15: White 747 Sample 5 low temperature cold bend failure

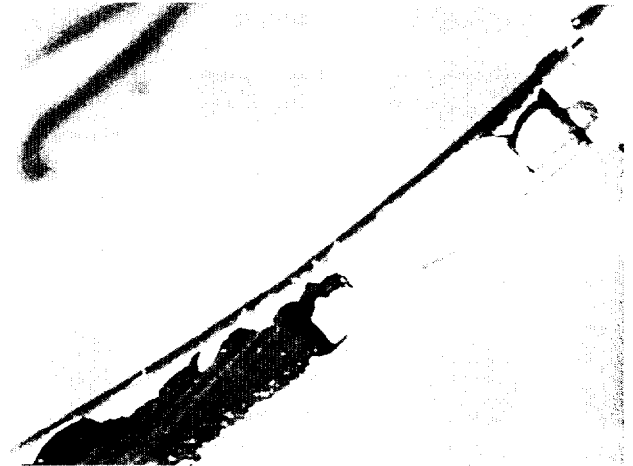

Photo B16: DC-10 Sample 4 Lifecycle failure

