



NATIONAL TRANSPORTATION SAFETY BOARD

Office of Aviation Safety
Washington, D.C. 20594

March 22, 2019

STRUCTURES

Group Chairman's Factual Report

ERA18FA120

**Appendix A – Figures
(6 pages)**

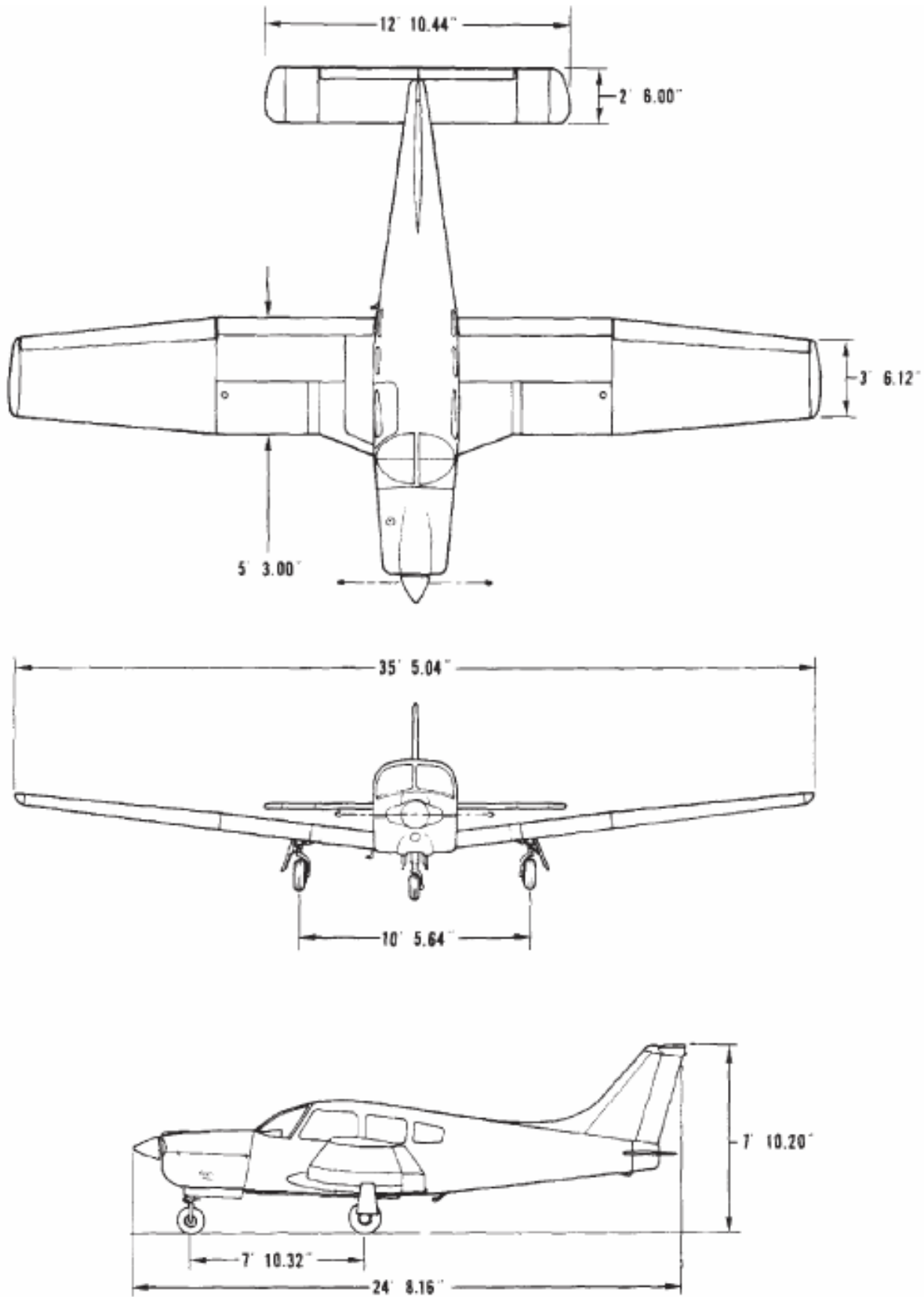

Figure 1 – Piper PA-28R-201 Arrow III 3-view drawing

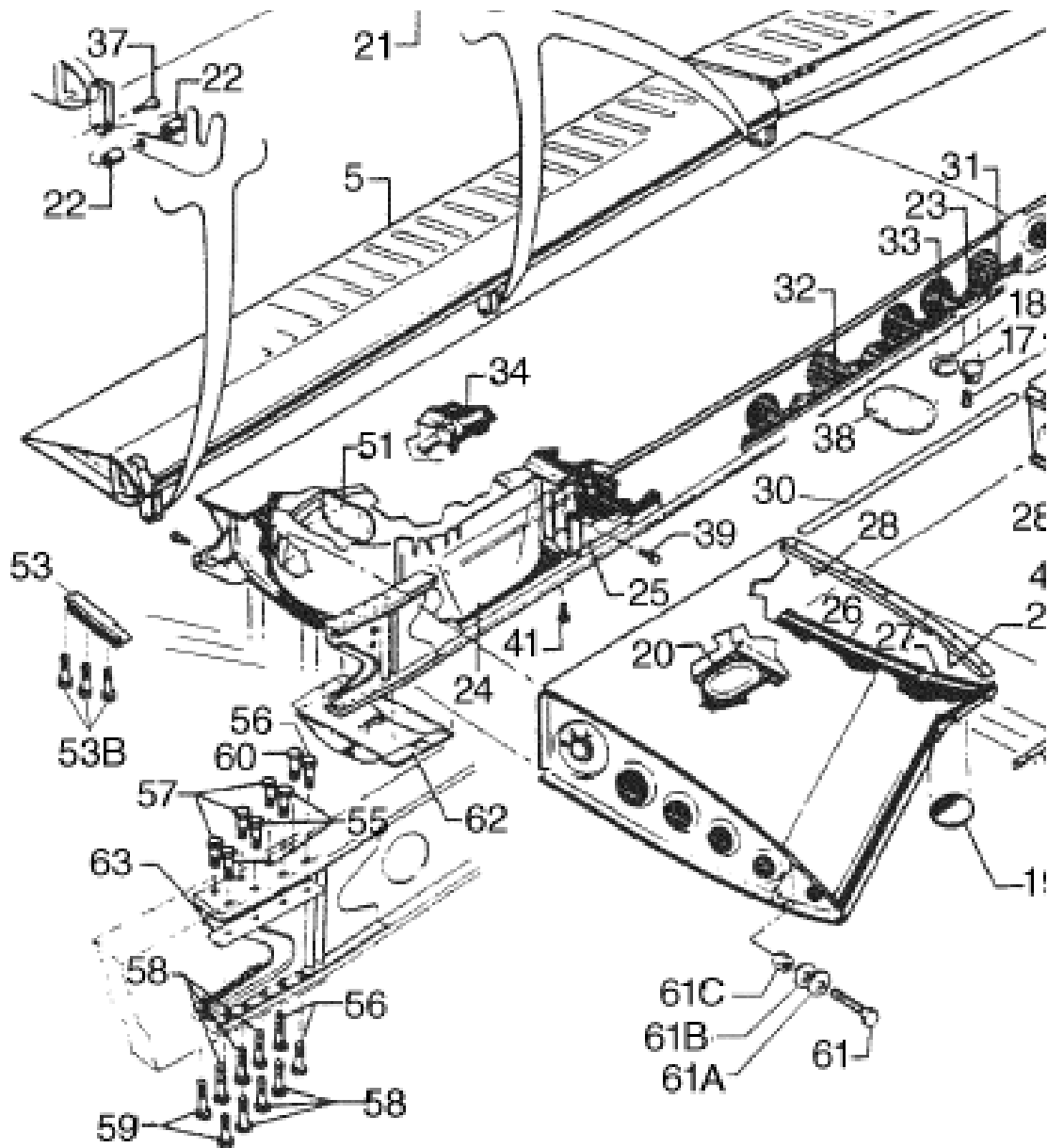

Figure 2 – Piper PA-28R-201 Wing installation as depicted in the PA-28R-201 Airplane Parts Catalog

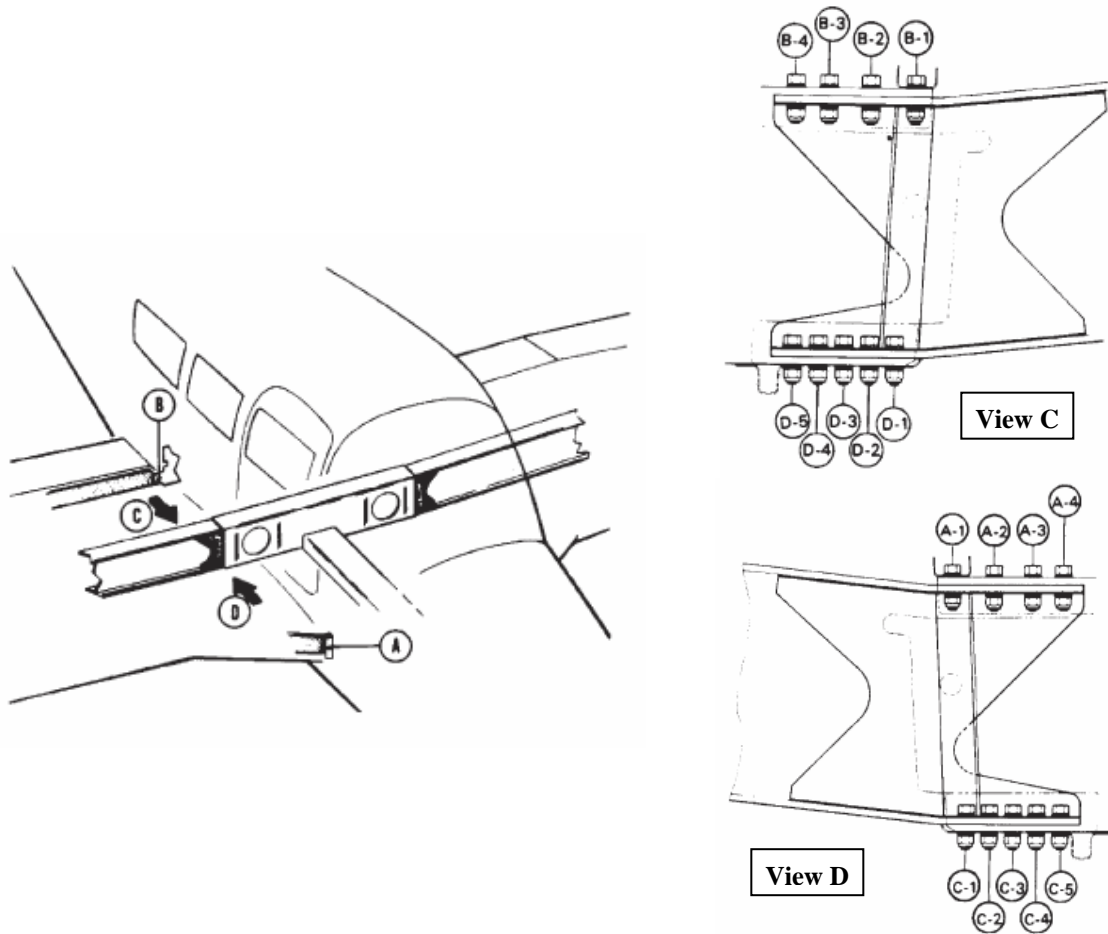

Figure 3 – Piper PA-28R-201 Main spar installation as depicted in the PA-28R-201 Airplane Maintenance Manual

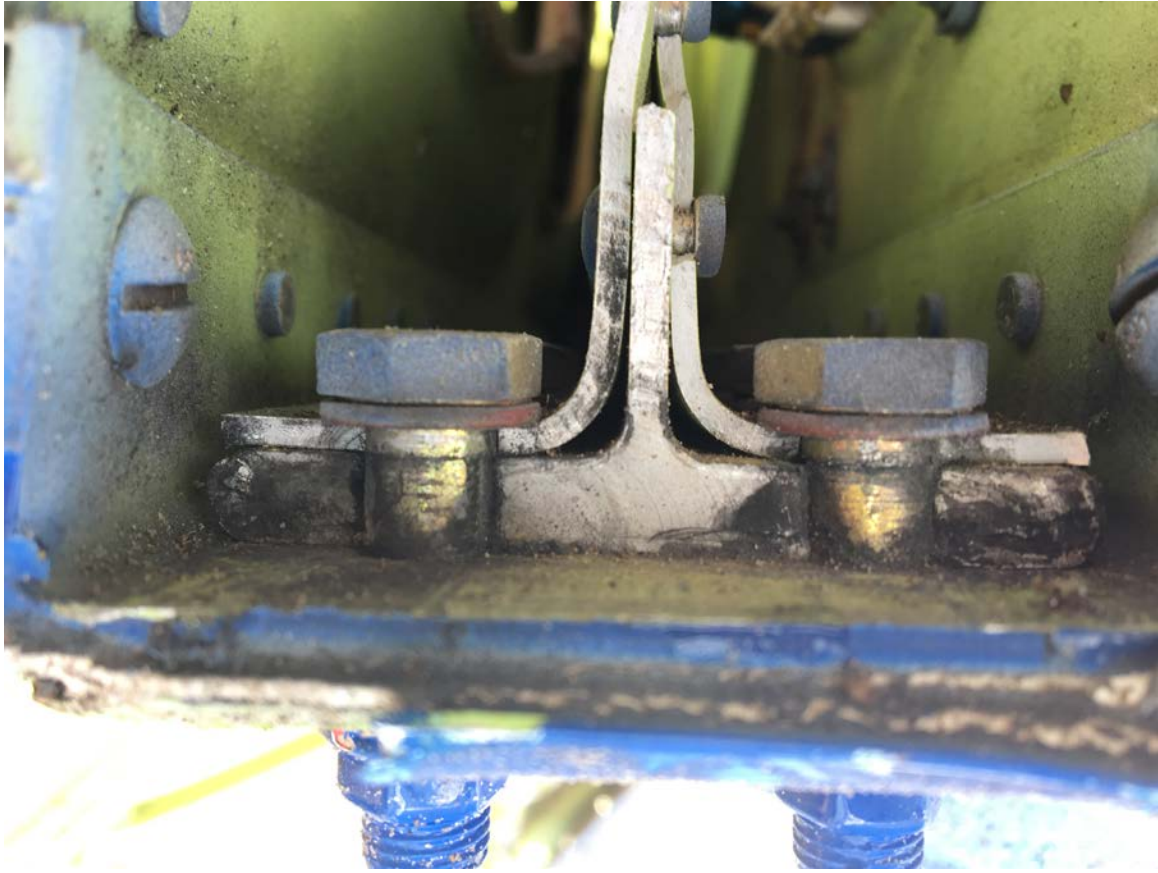

Figure 4 – N106ER Left wing lower spar cap fracture face, looking inboard



Figure 5 – N104ER Eddy Current indication in hole LC-1

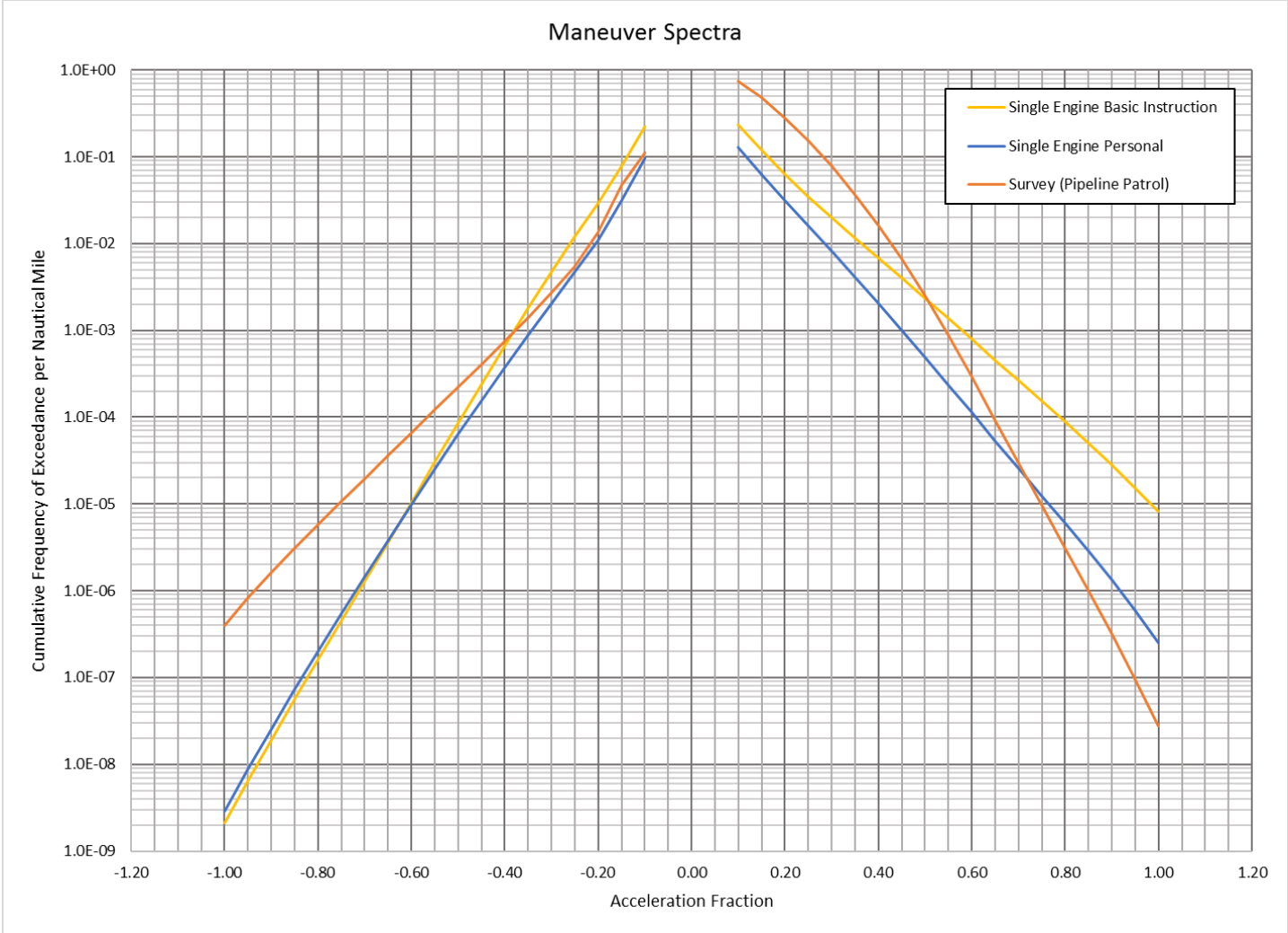

Figure 6 – AC23-13A maneuver spectra

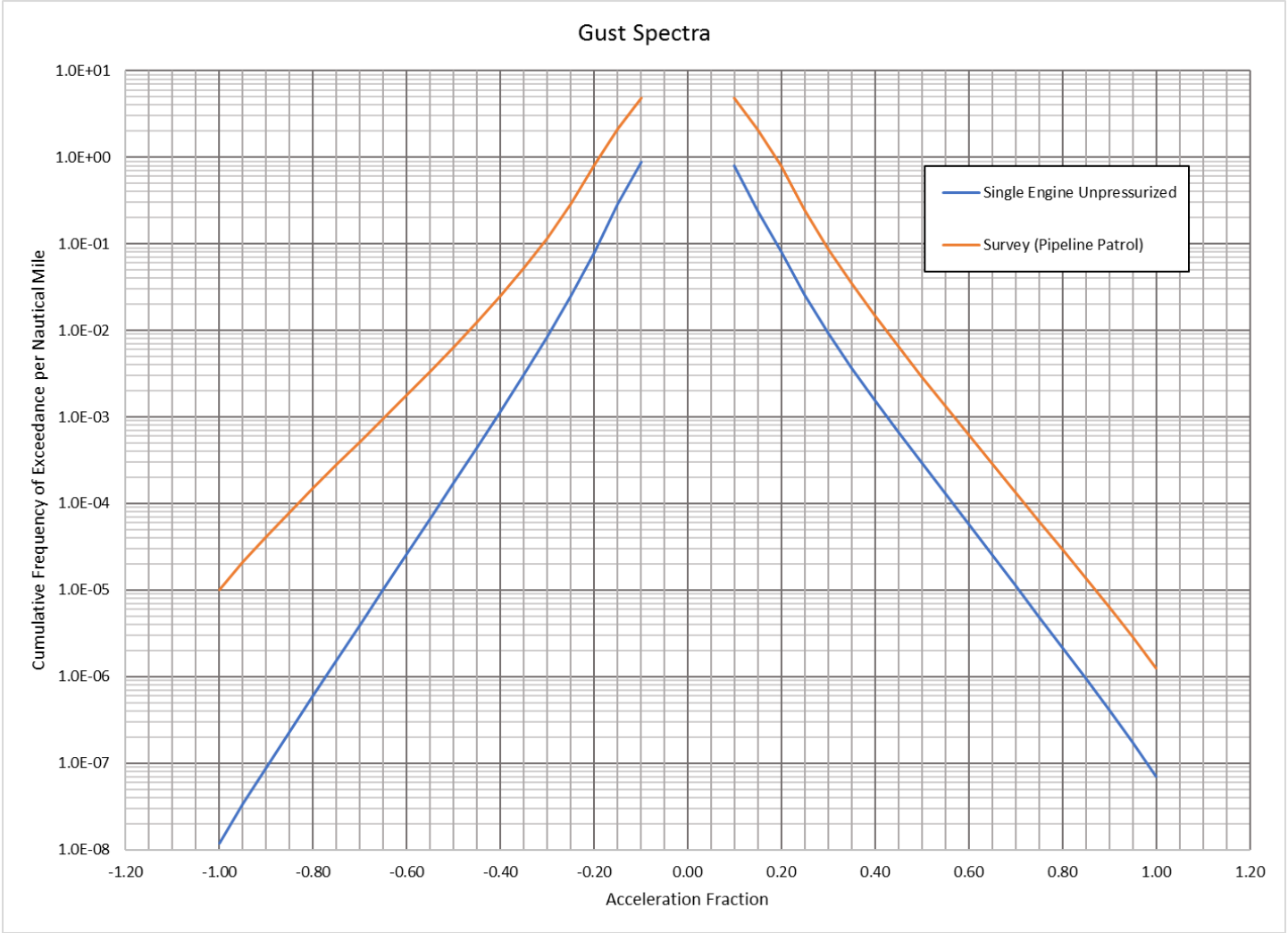

Figure 7 – AC23-13A gust spectra