

Docket No. SA-532

Exhibit No. 7-G

NATIONAL TRANSPORTATION SAFETY BOARD

Washington, D.C.

Addendum 1
Structures Group Chairman's
Attachment 3 to the Factual Report
Measured Fuselage Deformations

(23 Pages)



NATIONAL TRANSPORTATION SAFETY BOARD
Office of Aviation Safety
Washington, D.C. 20594

ADDENDUM 1

STRUCTURES GROUP CHAIRMAN'S FACTUAL REPORT

DCA09MA026
May 26, 2009

Attachment 3 Measured Fuselage Deformation

USAIR 1549 Ditching Body Contour Data – Lower Fuselage Frame 49 – Frame 65 April 2nd, 2009

Note: The data contained herein was collected using approximate means to capture/document gross airframe body deformations, and are not intended to be a precise measurement of actual final displacements.

It should also be noted that the damaged fuselage structure aft of frame 59 between stringer 38L and 33R was largely unsupported. This section deflected during the inspection, so was subject to larger variation and error in measurements.

Measurements were taken both inside and outside the fuselage and the displacements determined as shown on the following pages

Body Contour – External Measurement Methodology

Measurement methodology:

- We created a reference yz - axis system.
 - $y=0$ at the vertical line tangent to the right side fuselage external surface at Frame 56.
 - $z=0$ on a horizontal reference surface.
- Using this reference axis, the airplane centerline is at $y=78.5$ inches.
- For all measurements taken aft of Frame 56, the horizontal reference surface was always aligned such that $y=78.5$ inches was at the airplane centerline (i.e., at stringer 44, $y=78.5$). Airplane centerline was marked by chalk line with centerline points marked by using a plumb line from Frame 47 - stringer 44 and the centerline of the horizontal stabilizer attachments.
- y and z coordinates were recorded at each stringer/frame interface on the external surface of the airplane between stringers 24L and 24R (where available) from Frame 56 to Frame 70.

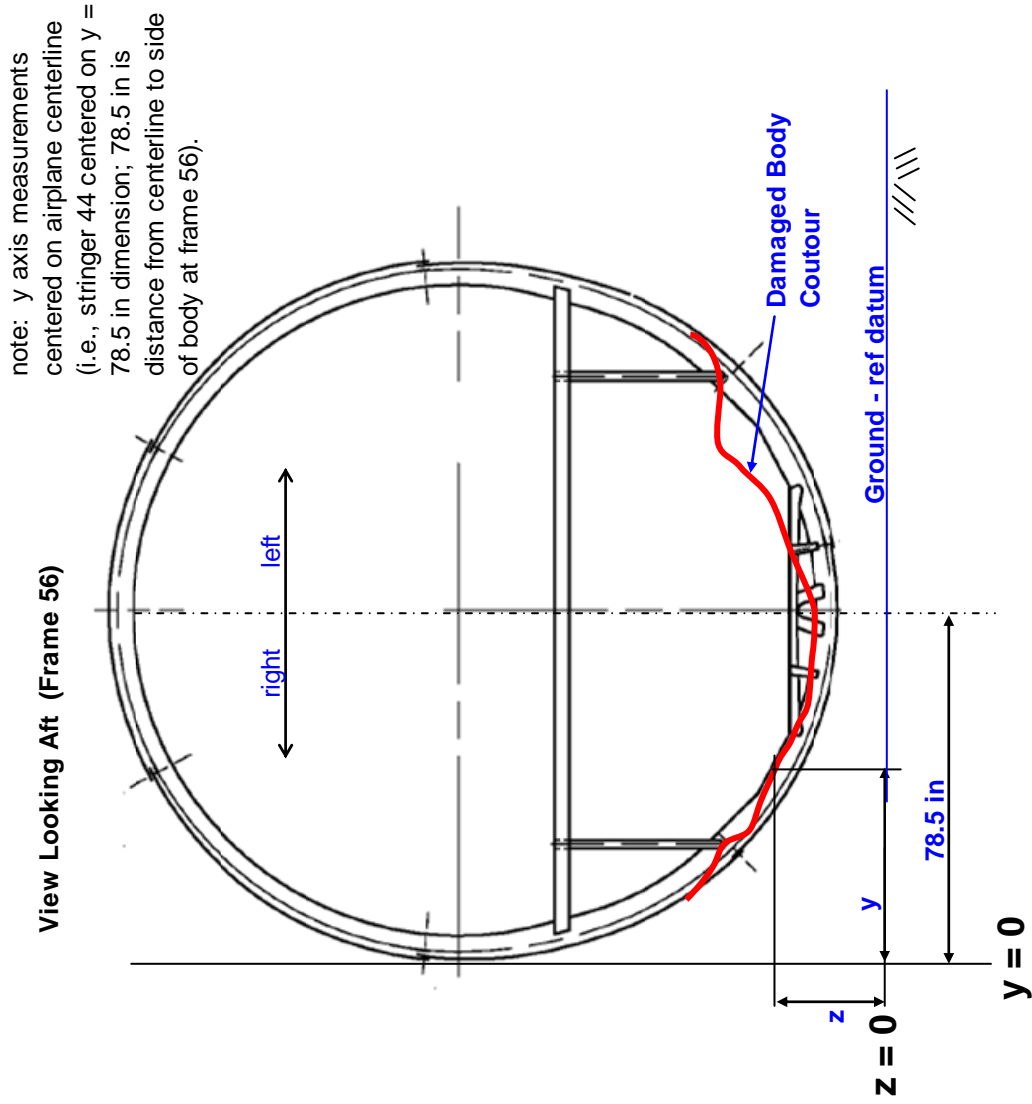

Method used for Out-Of-Plane-Deformation (OOPD) Determination (using deformation measurements taken inside the aircraft)

1. At each frame station a reference point was marked onto the bottom flange of the pax crossbeam at the aircraft centre line ($y=0, z=-644\text{mm}$)
2. At each frame station the distance was measured between this reference point and the fuselage skin at relevant stringer positions (R_m)
3. The out of plane displacement (OOPD) at each relevant stringer was then determined by subtracting this measured distance from the distance between the reference point and the original stringer reference datum (R_t)

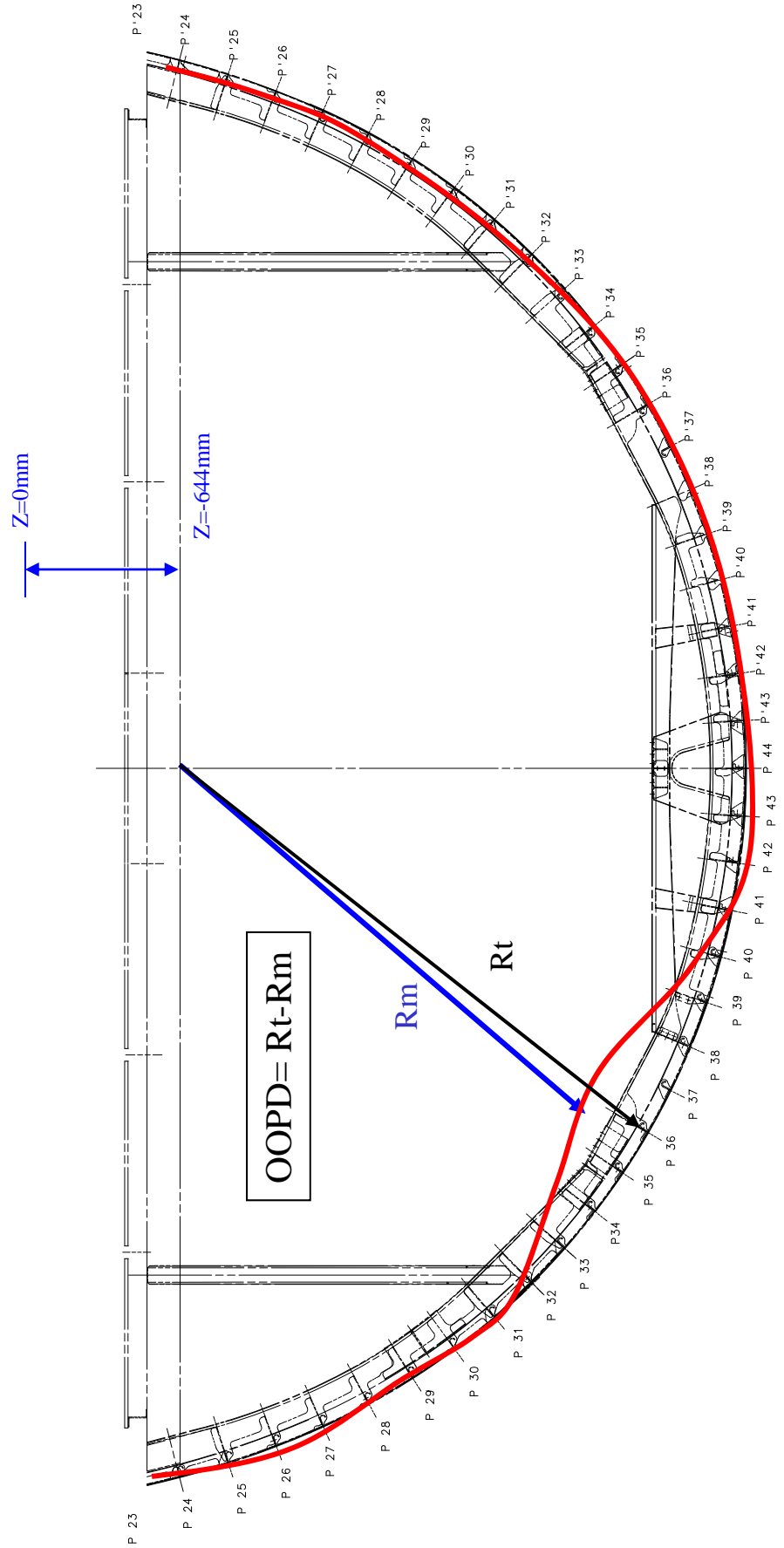

Overview of all OOPD measurements (mm, +ve is inwards, from internal measurements only)

	C49	C50	C51	C52	C53	C54	C55	C56	C57	C58	C59	C60	C61	C62	C63	C64	C65
P'24								12	2	10	5	7	14				
P'25								47	97	43	44	60	49				
P'26								41									
P'27																	
P'28																	
P'29								122	204	239	247	234	209	39	0	-42	
P'30								95	156	211	236						
P'31								22							28		
P'32								6	74	183	273	322	235	139	102	68	1
P'33													224	151	115	106	24
P'34													227	160	132	117	30
P'35								-2	126	195	273	290	220	181	171	124	17
P'36											206	271	263	242	191	124	10
P'37								55		142			203	216	159	111	-1
P'38												145	185	187	130	86	
P'39		29	45	65					88	75	90	119	136	135	86	59	
P'40		30	60	66						46	53	78	80	41	16		
P'41		42	52	76	80	92	107	122	130	125	84	59	65	23			
P'42		61	81	91	101	113	131	174	137	94	68						
P'43		53	73	98	108	28	138	153		78	61						
P44										128	105	119					
P43		33	53	78	63	69	113	153	160	201	178	161					
P42		16	21	46	51	112	101	71	234	217	194	158					
P41		32	75	102	105	132	132	122	130								
P40		10	30	50	70	84	90	103		94	76	73					
P39		14	19	29	52	62	69	79	89	98	90	69					
P38																	
P37																	
P36										79	98	66					
P35								38									
P34																	
P33																	
P32																	
P31																	
P30																	
P29																	
P28																	
P27																	
P26																	
P25																	
P24																	

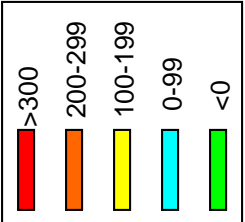

Cargo Door

Too flexible to measure

Missing Panels

OOPD

Frame by Frame

Note on all pages P## refers to Stringer ##

FR49

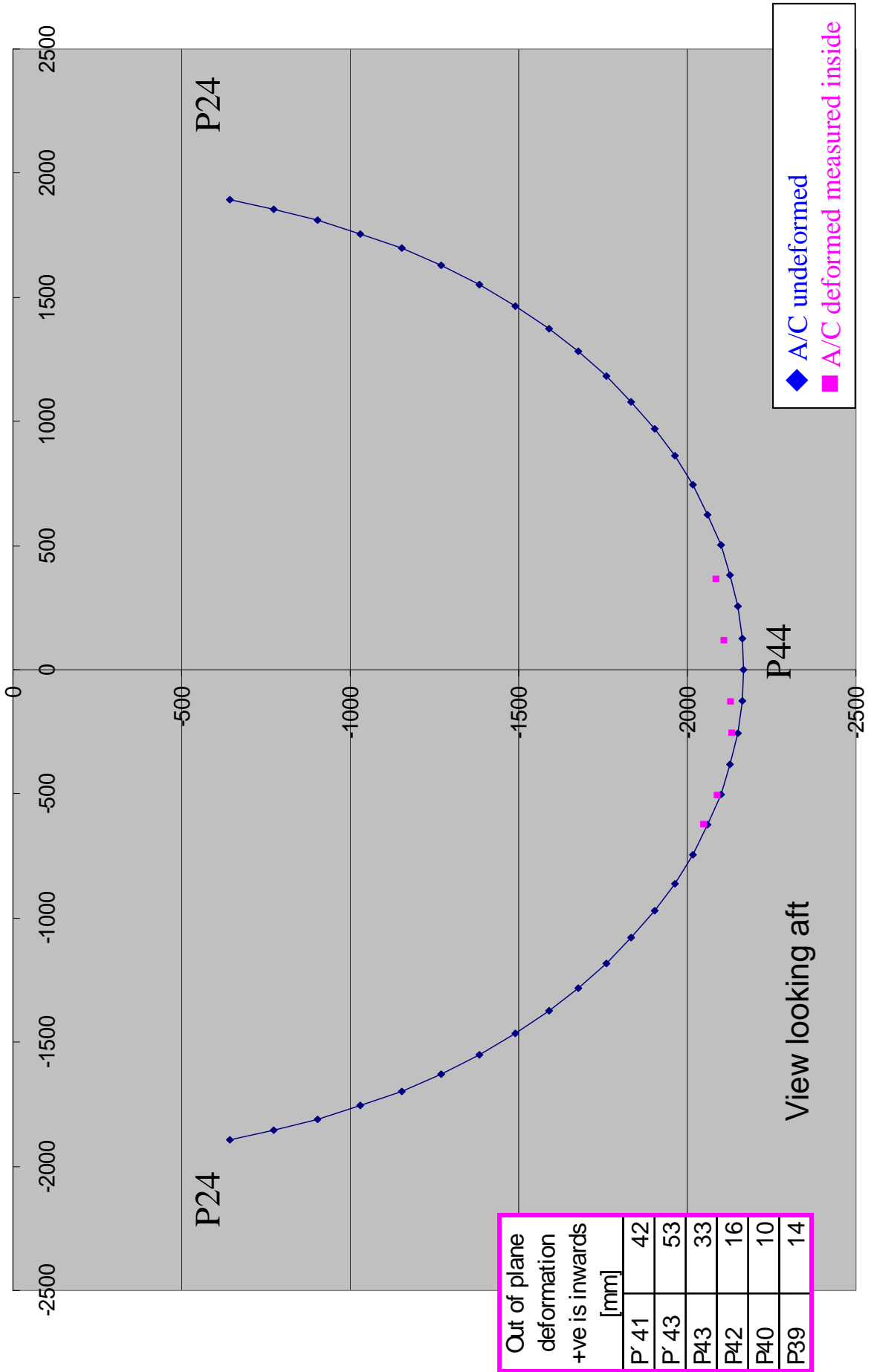

FR50

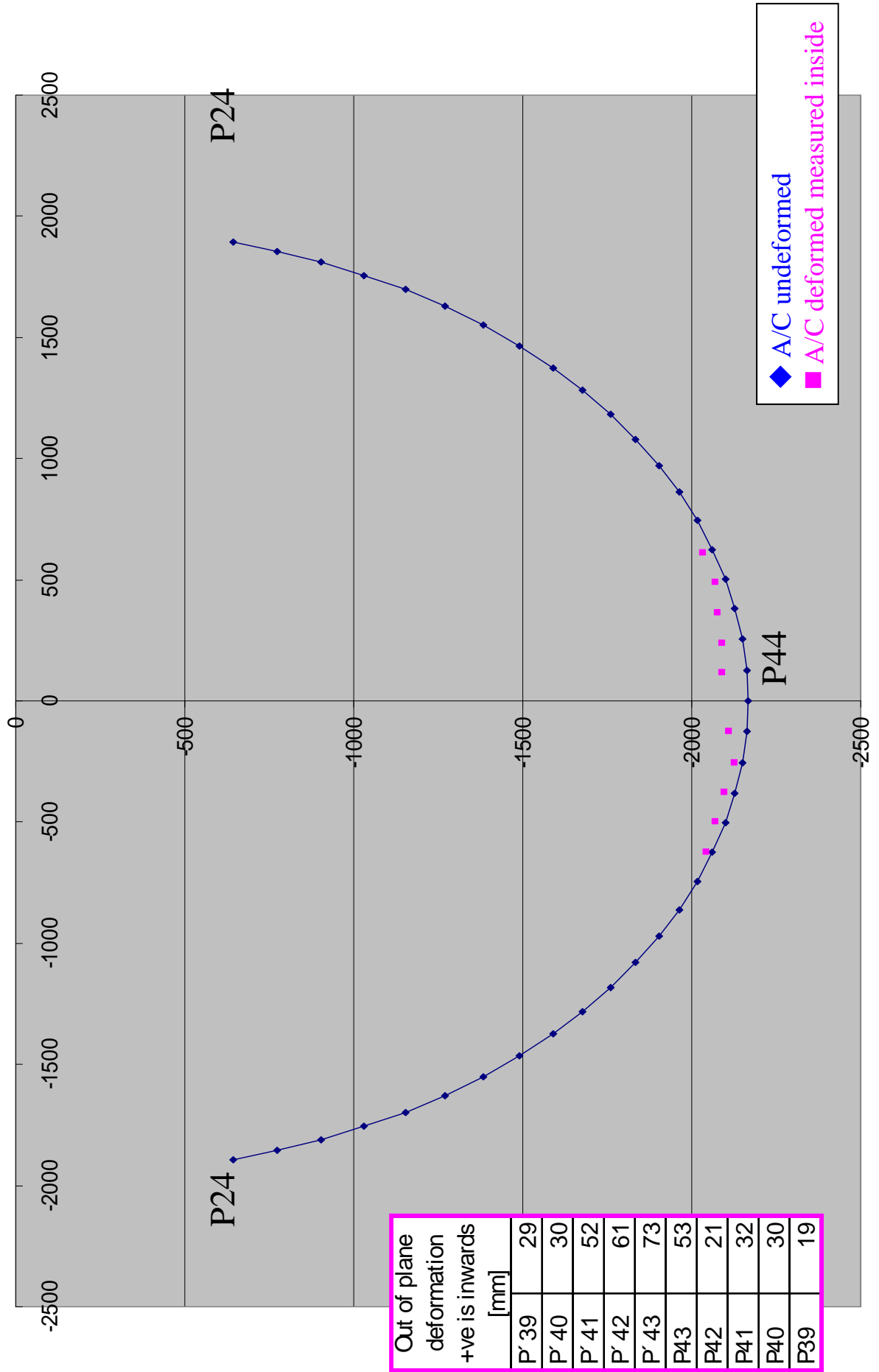

FR51

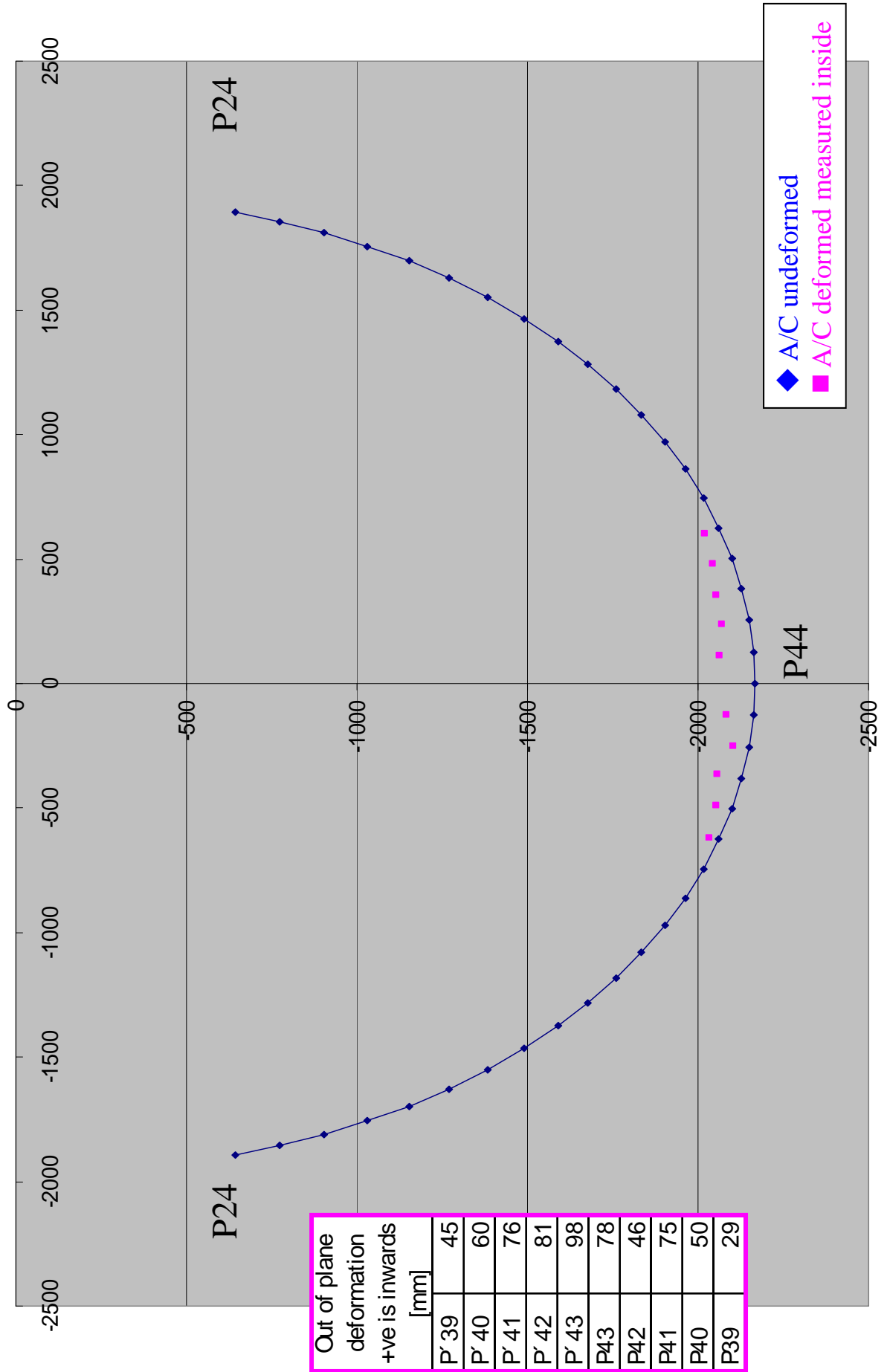

FR52

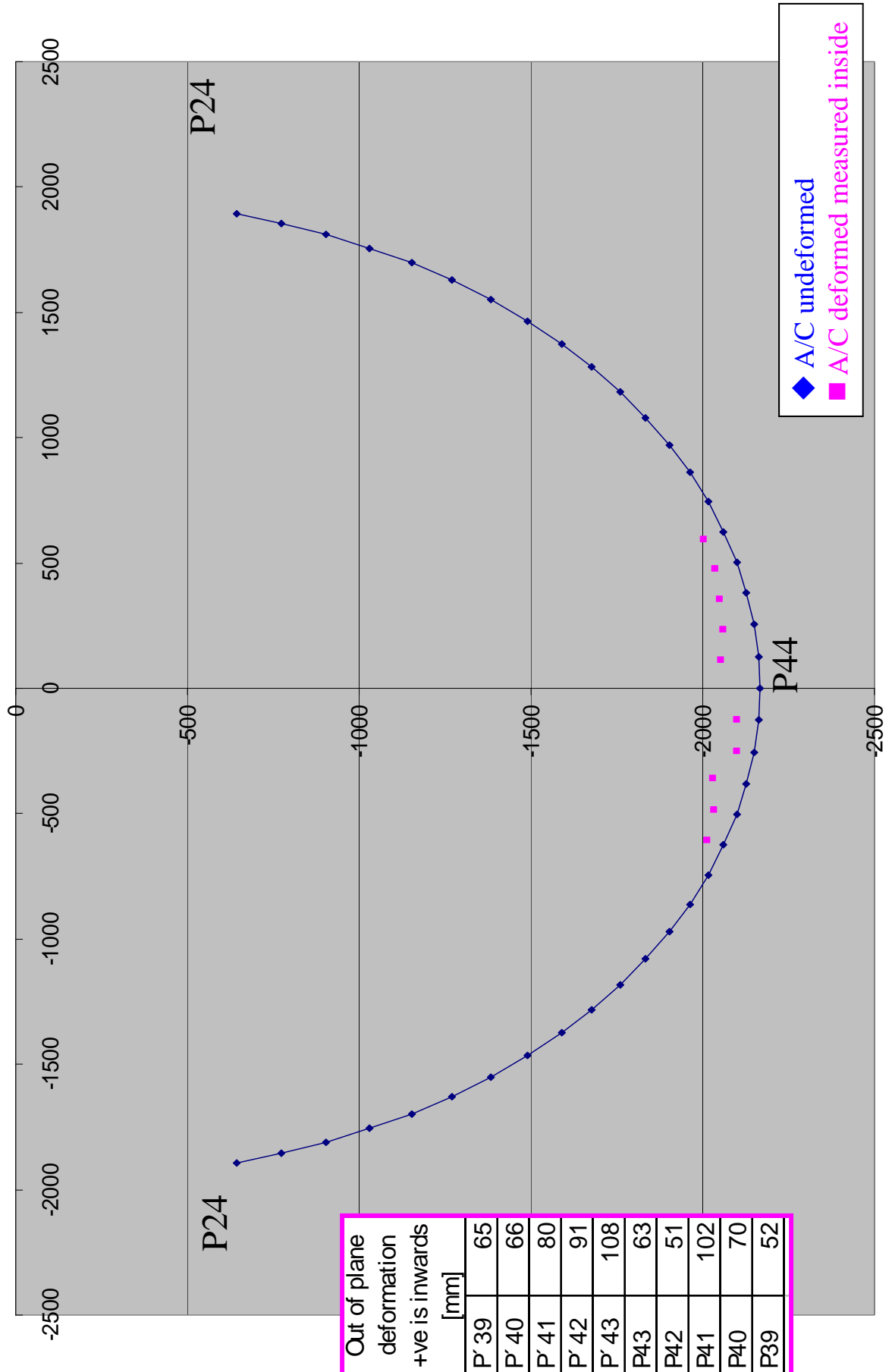

FR53

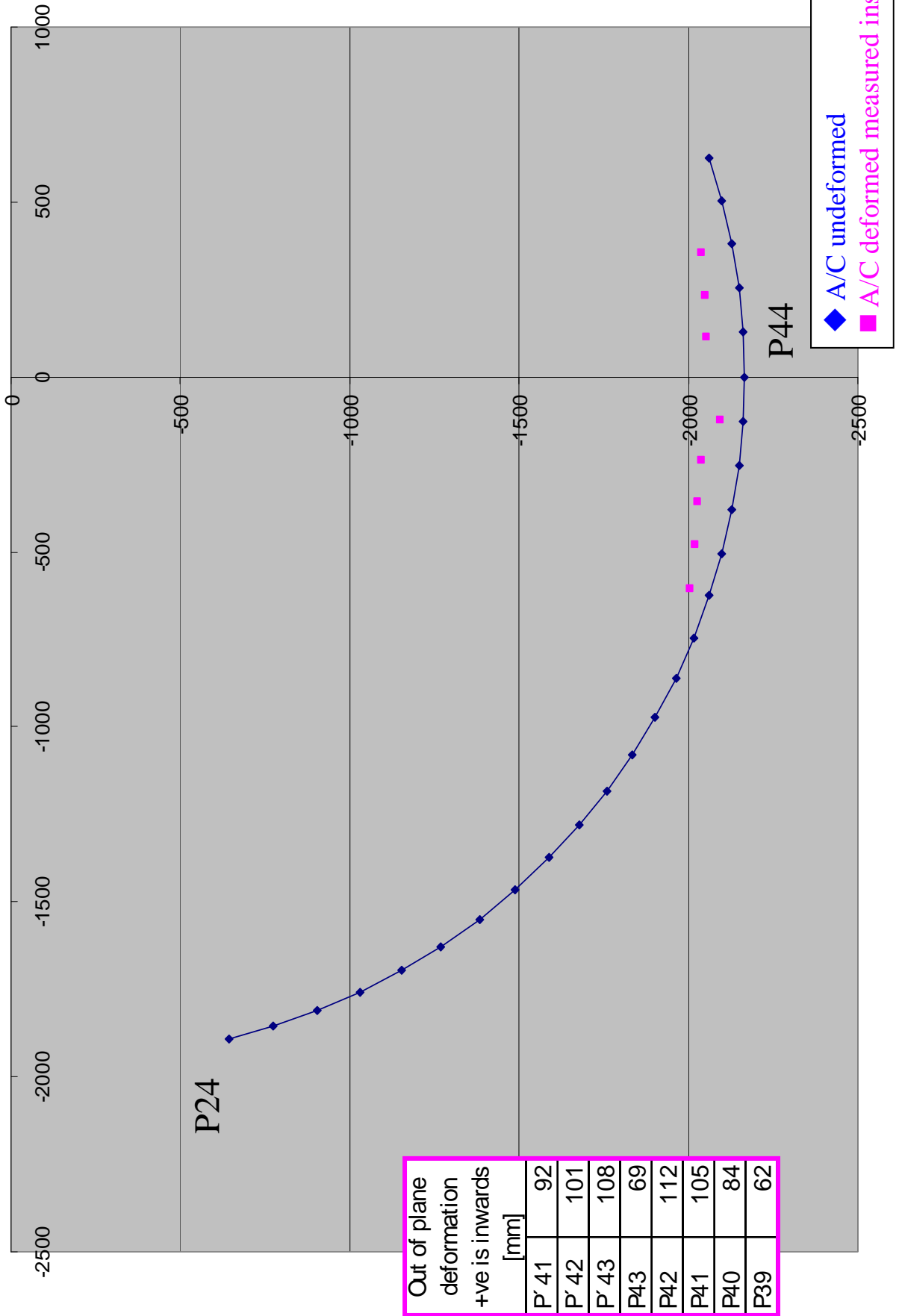

FR54

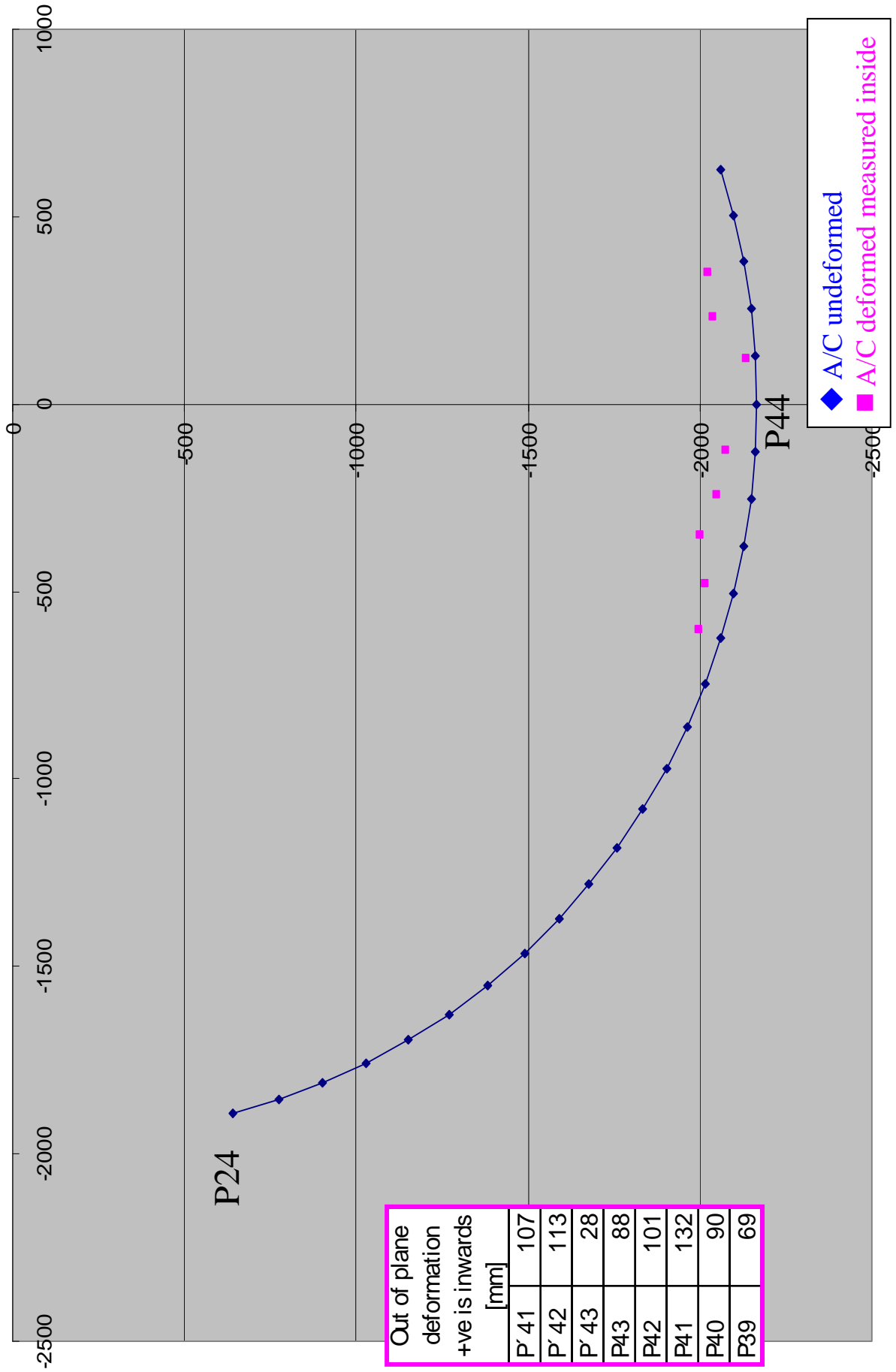

FR55

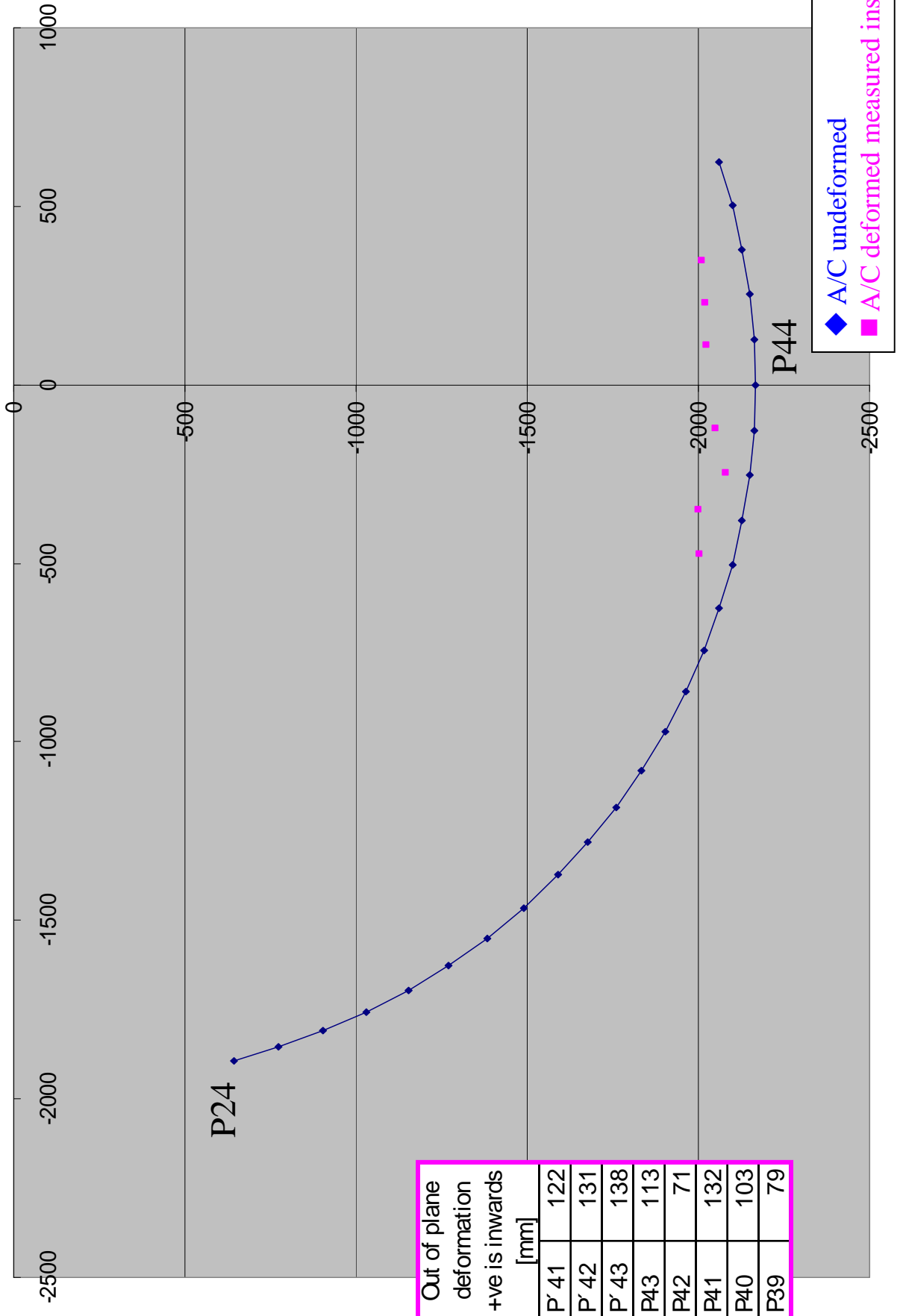

FR56

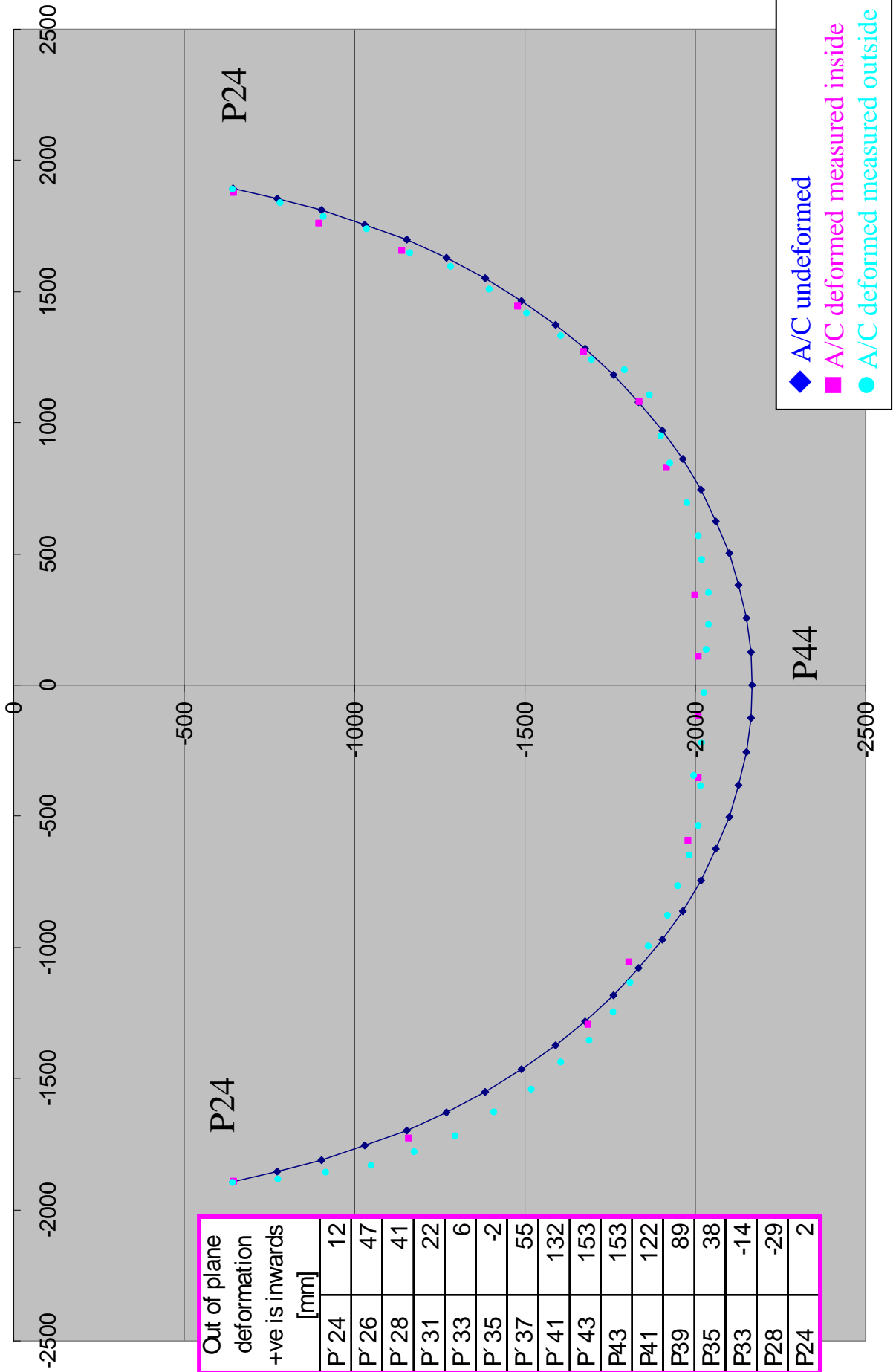

FR57

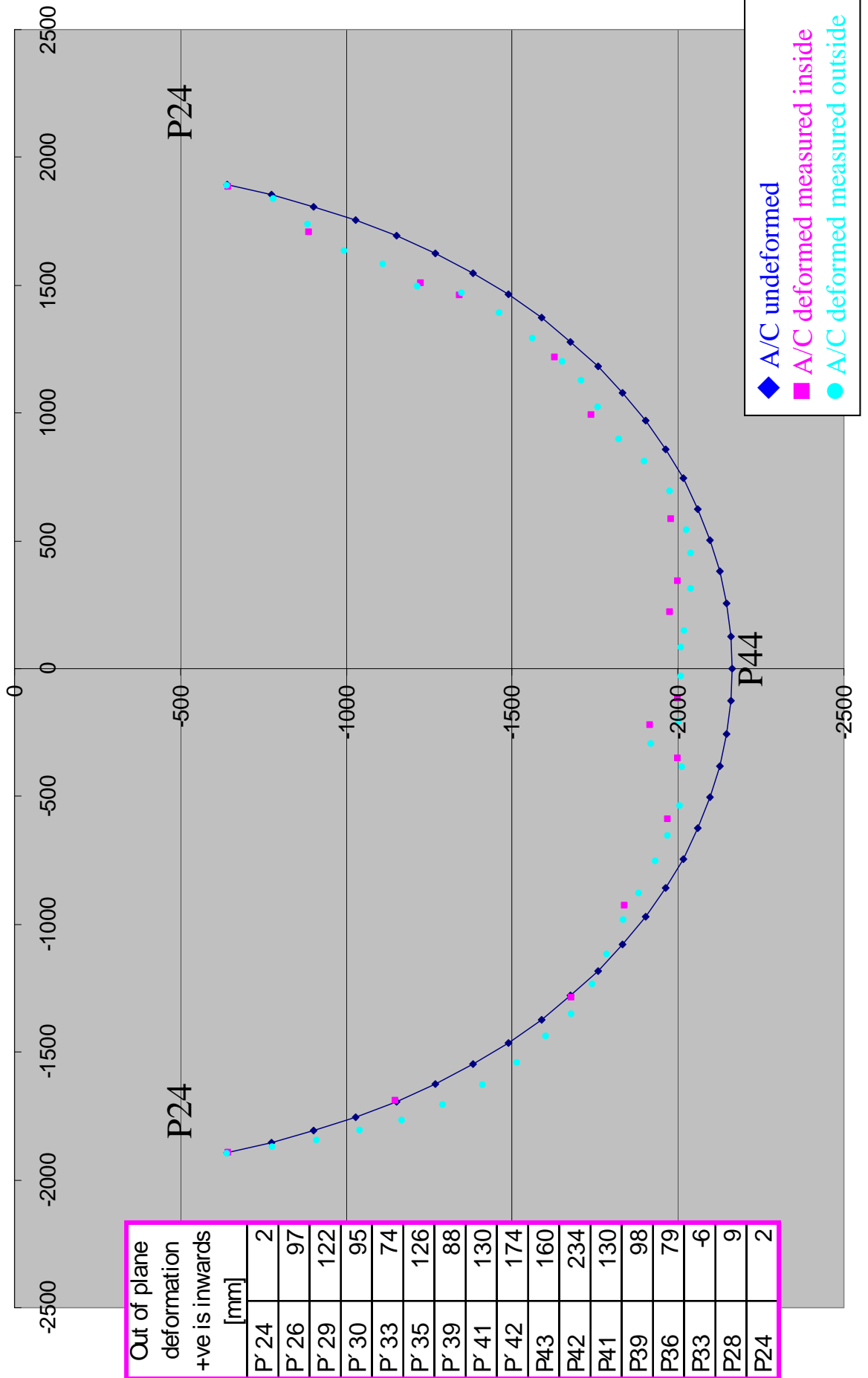

FR58

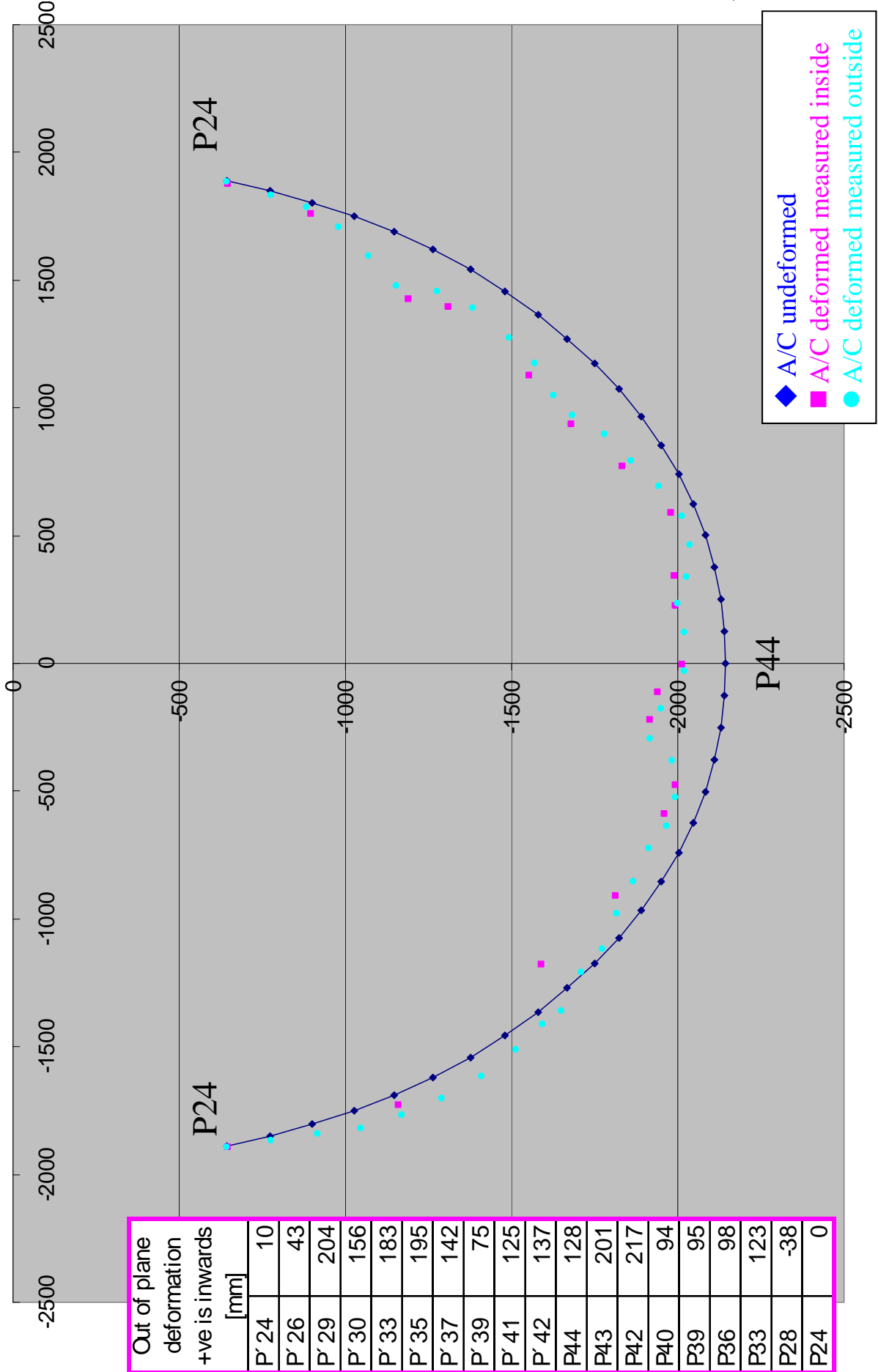

FR59

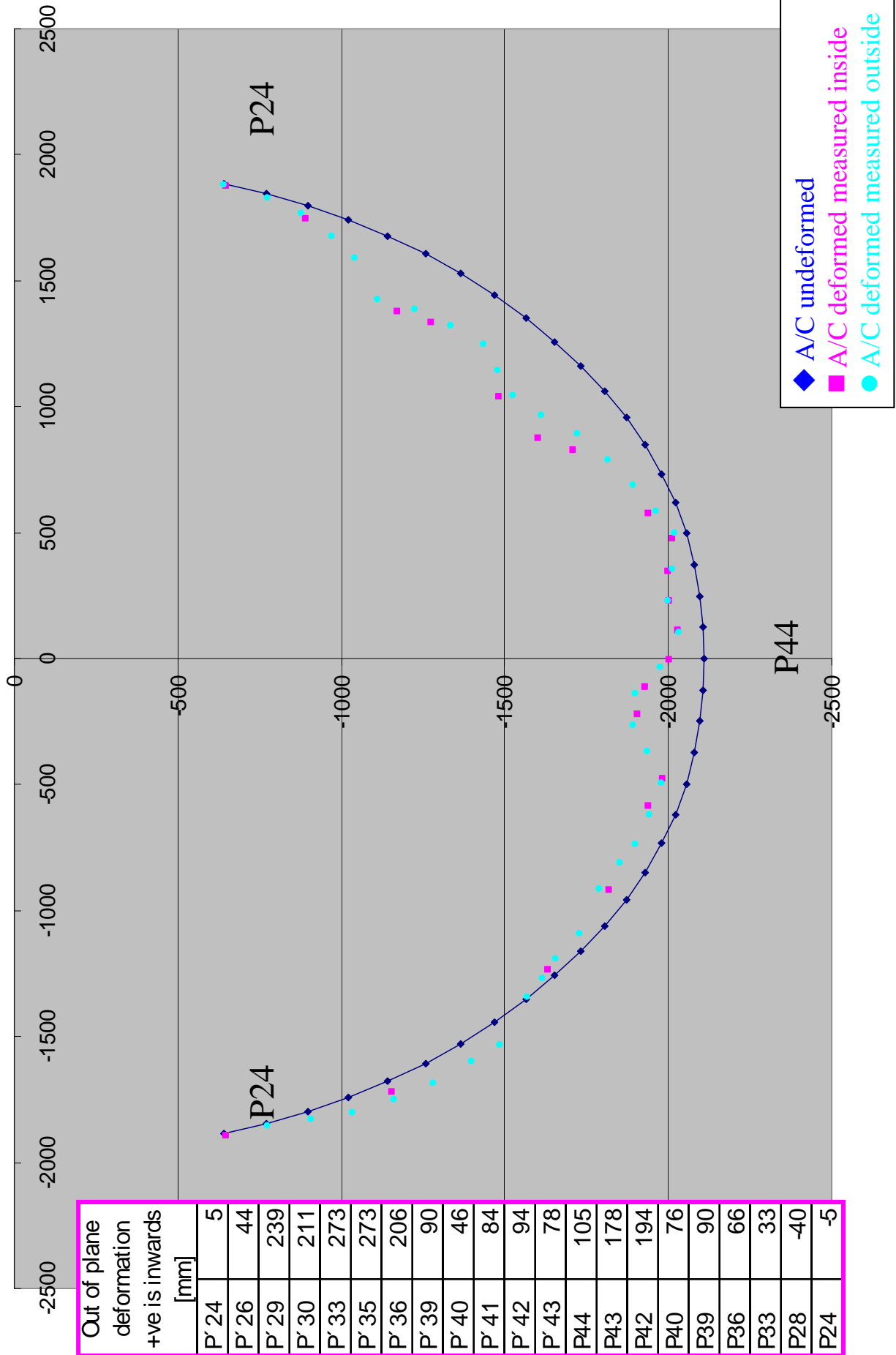

FR60

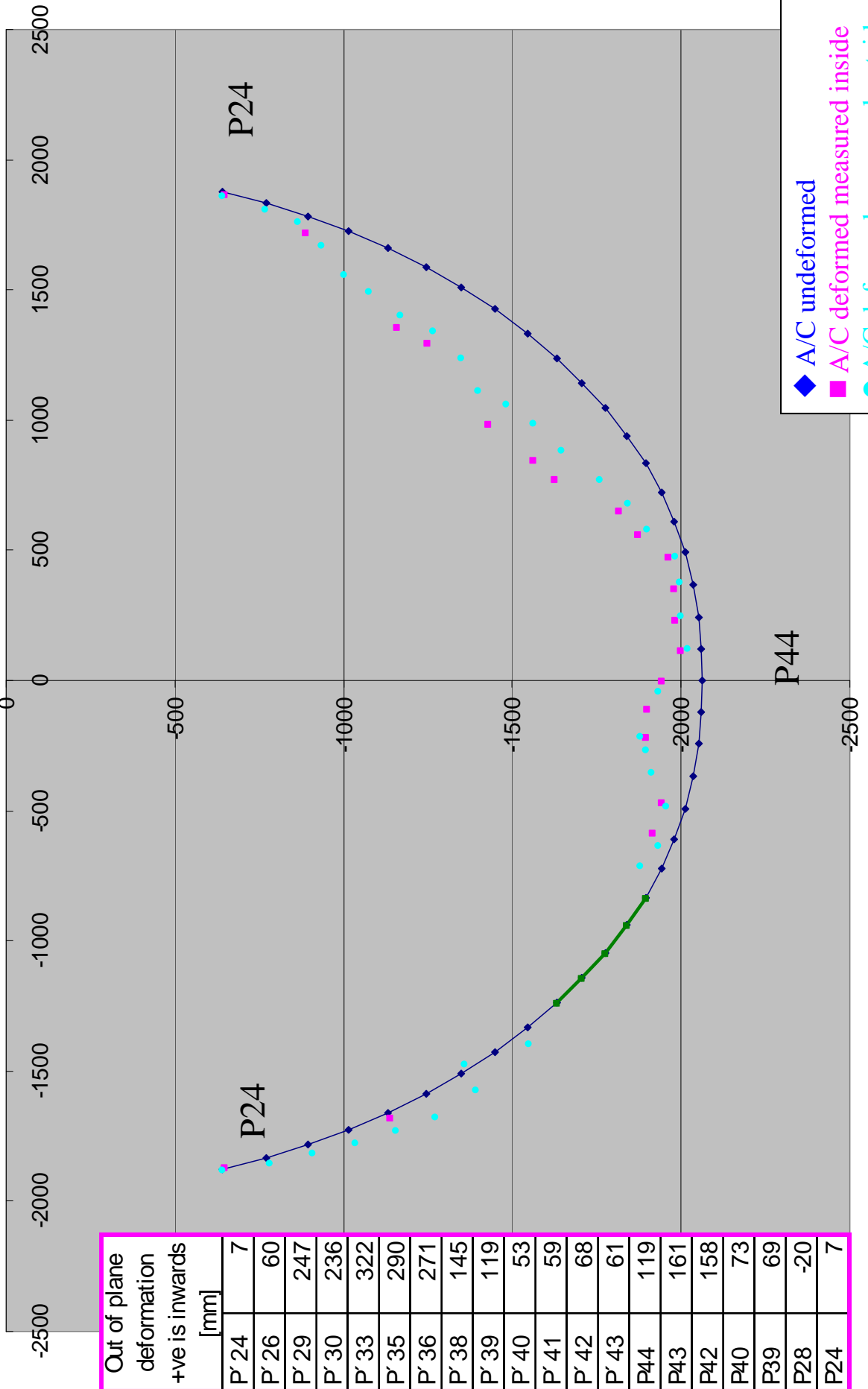

FR61

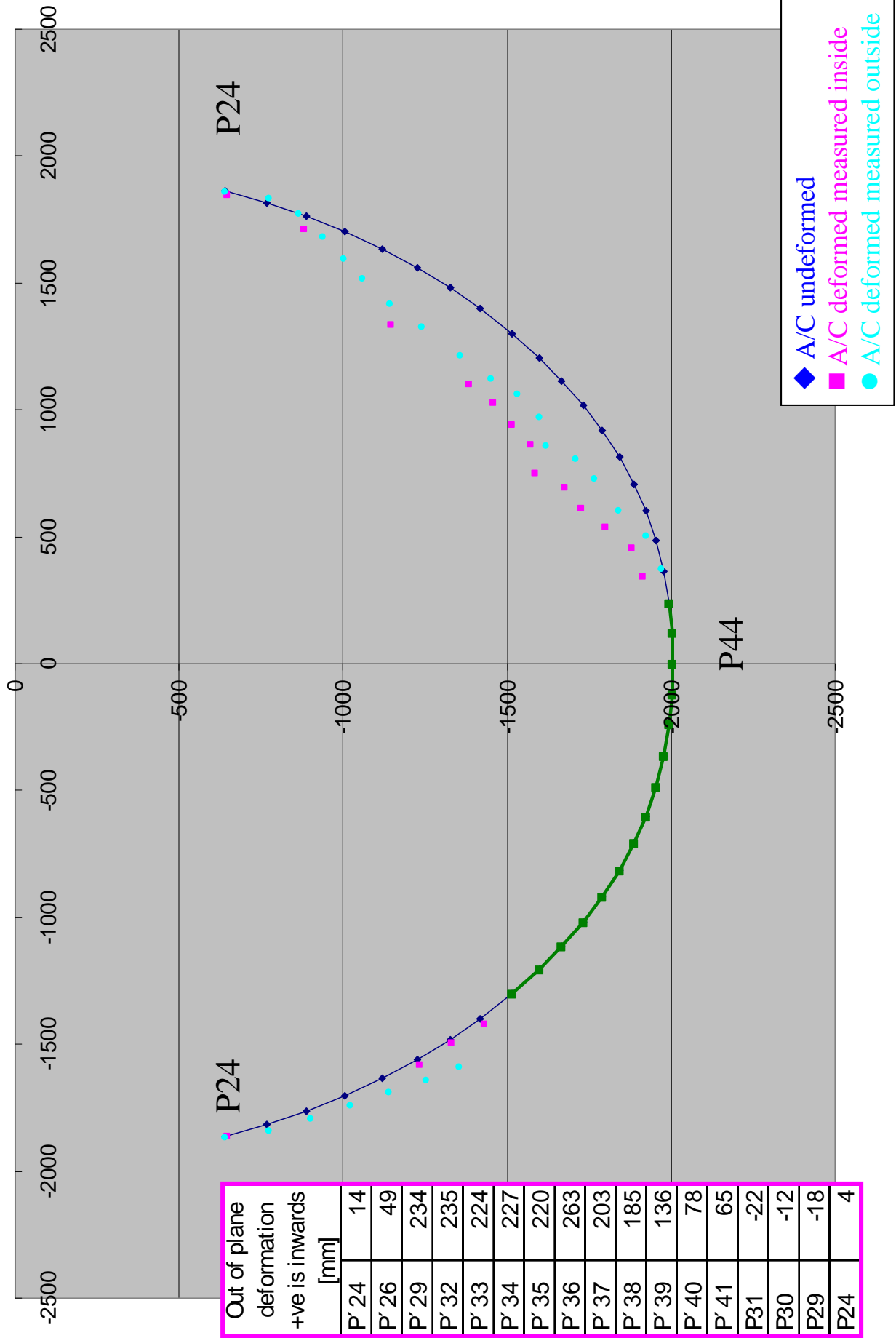

FR62

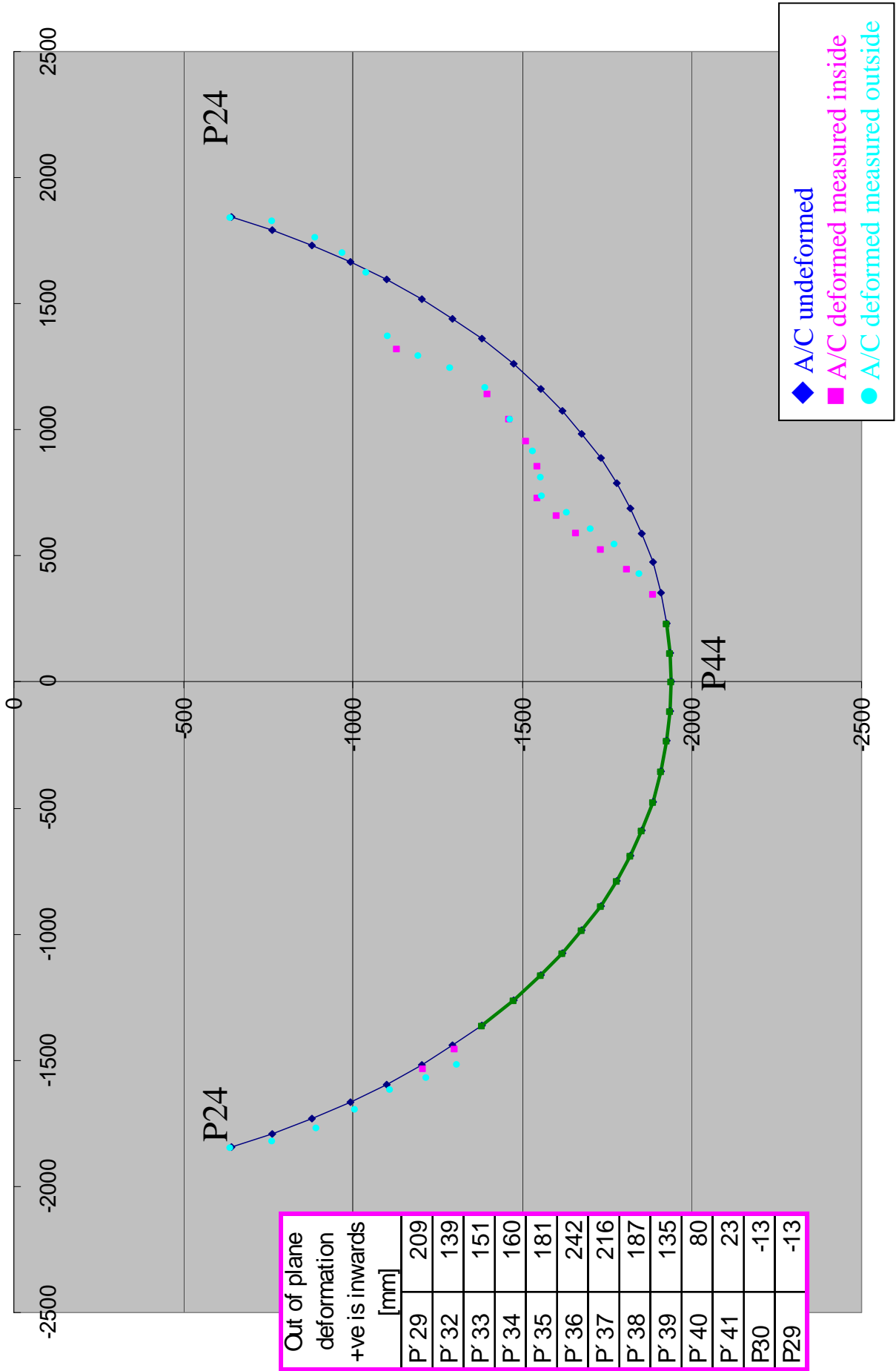

FR63

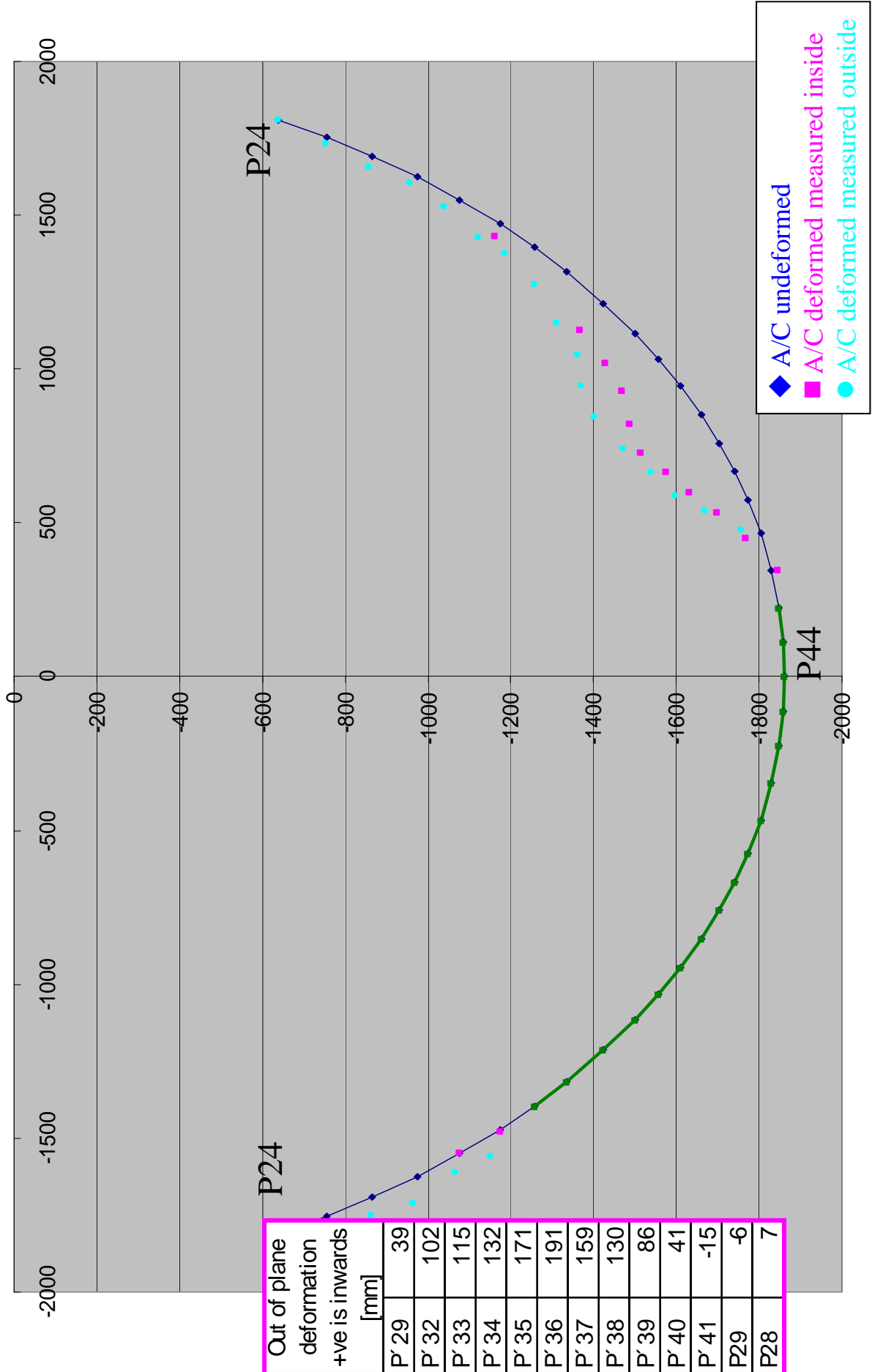

FR64

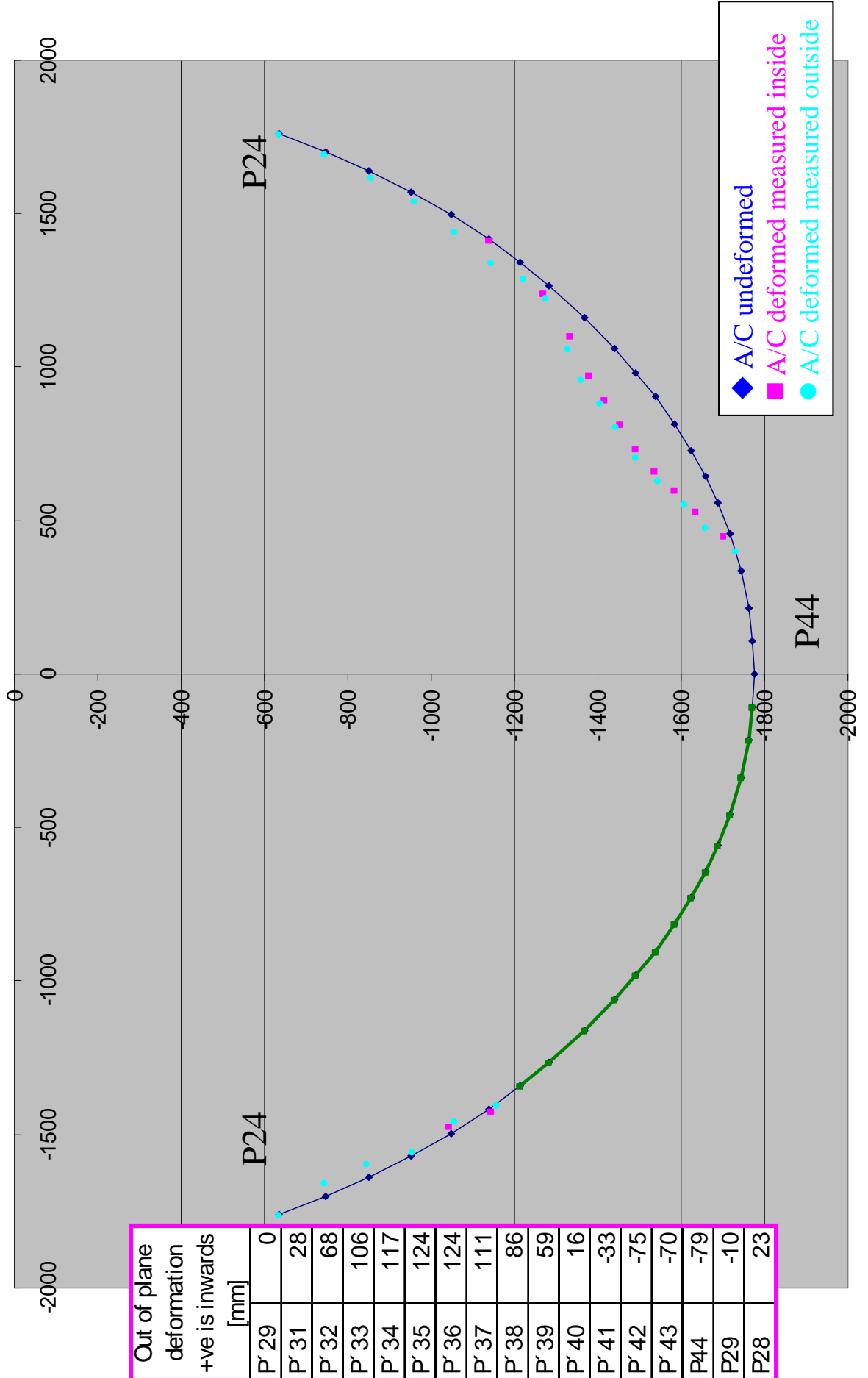

FR65

