

**Docket No. SA-532**

**Exhibit No. 7-E**

**NATIONAL TRANSPORTATION SAFETY BOARD**

**Washington, D.C.**

Addendum 1  
Structures Group Chairman's  
Attachment 1 to the Factual Report  
Figures

(22 Pages)



**NATIONAL TRANSPORTATION SAFETY BOARD**

Office of Aviation Safety  
Washington, D.C. 20594

**ADDENDUM 1**

**STRUCTURES GROUP CHAIRMAN'S FACTUAL REPORT**

DCA09MA026

May 26, 2009

Attachment 1  
Figures

Accident #: DCA09MA026 | N106US

Description: Structural Description.

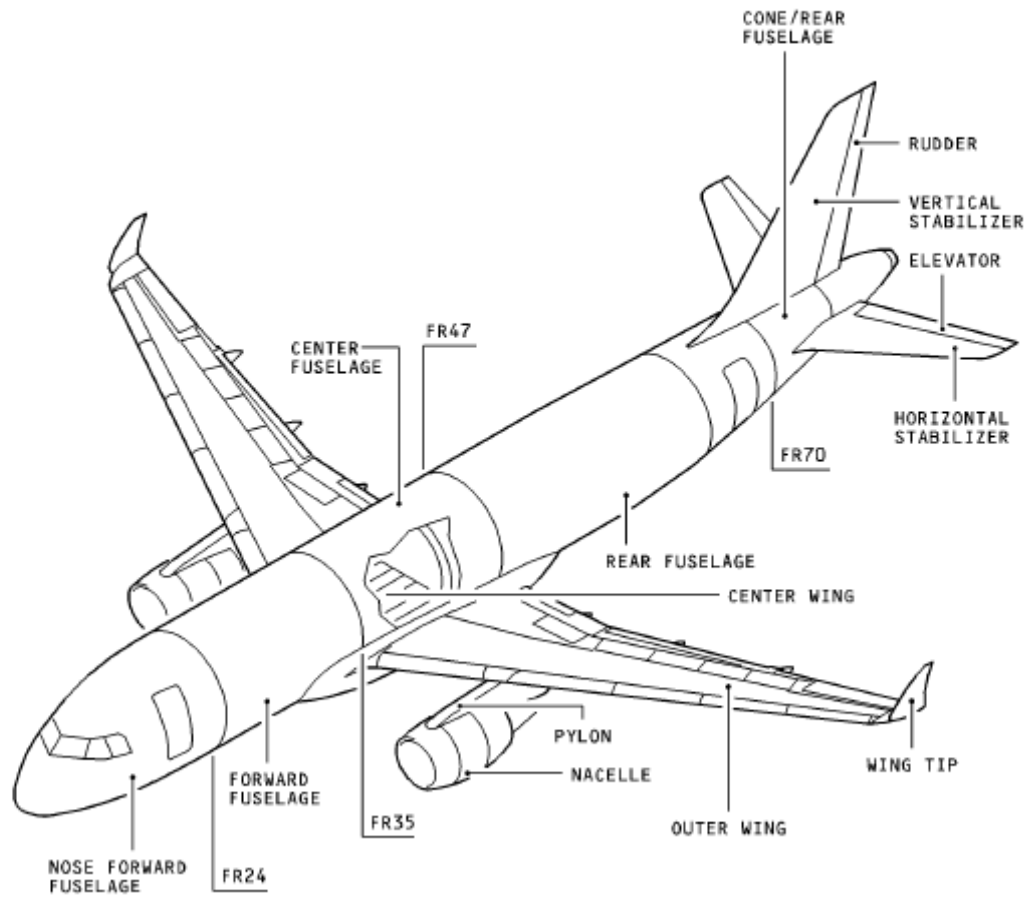

Figure 1

Accident #: DCA09MA026 | N106US

Description: Airplane Dimensions.

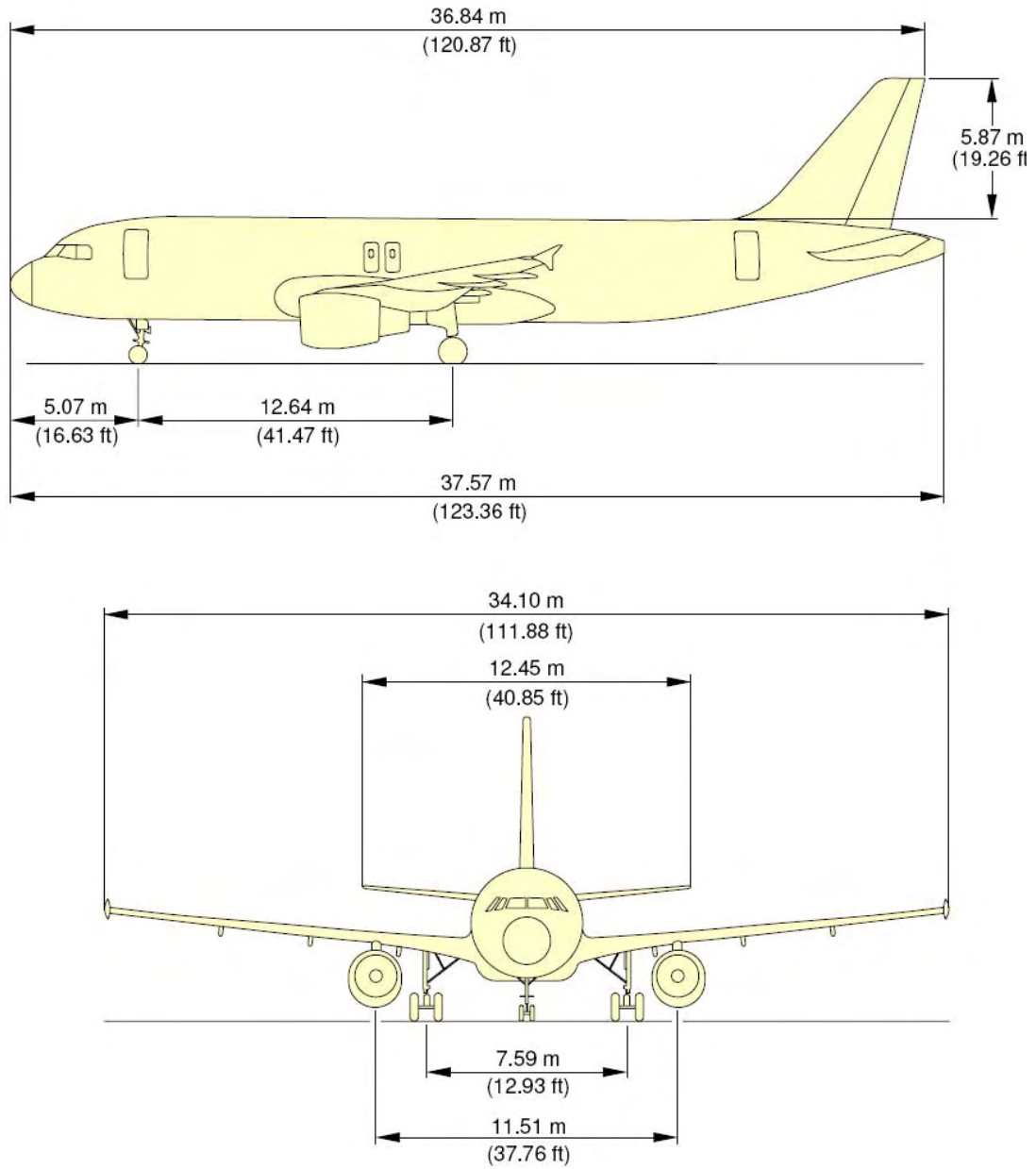
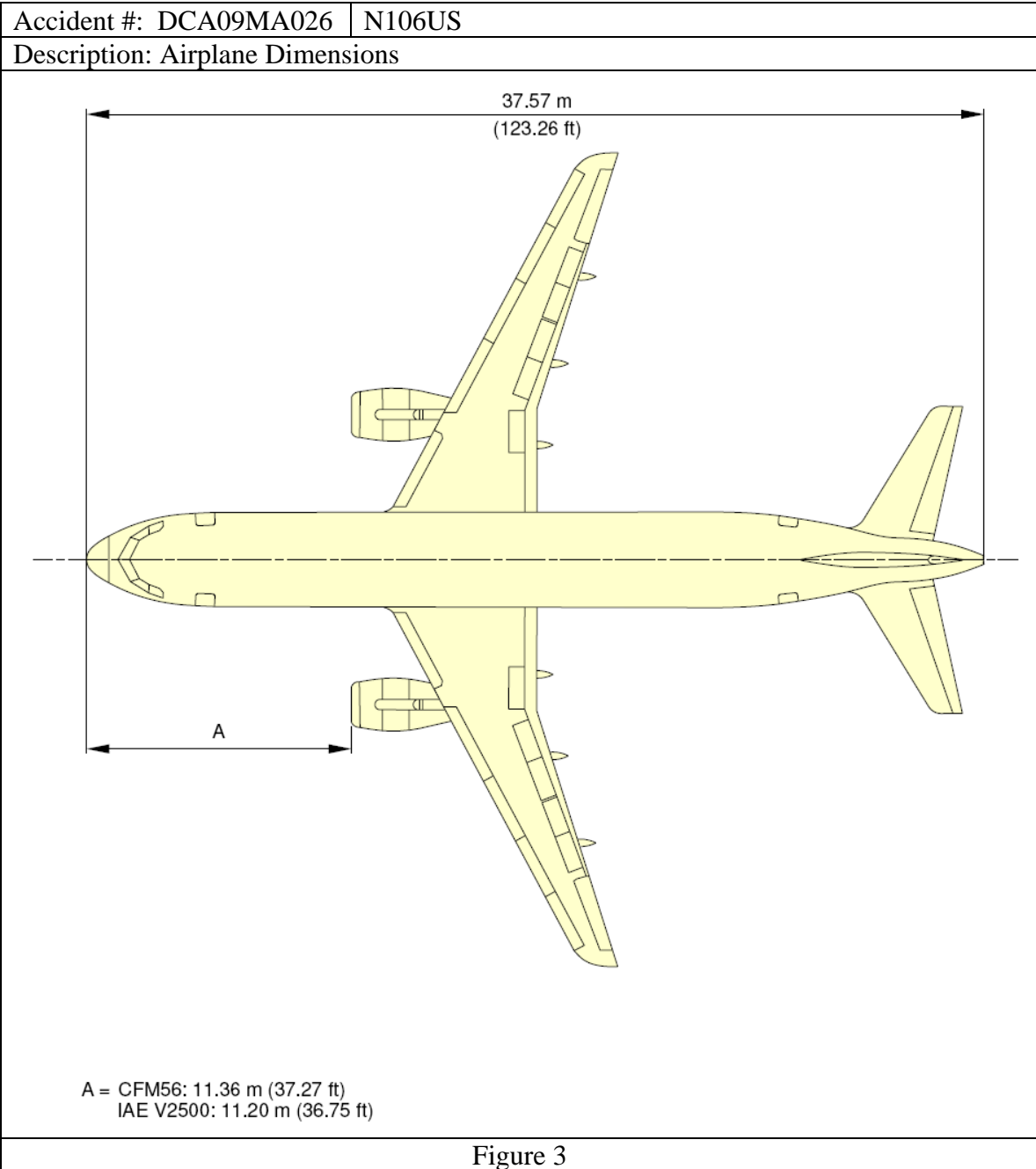

Figure 2



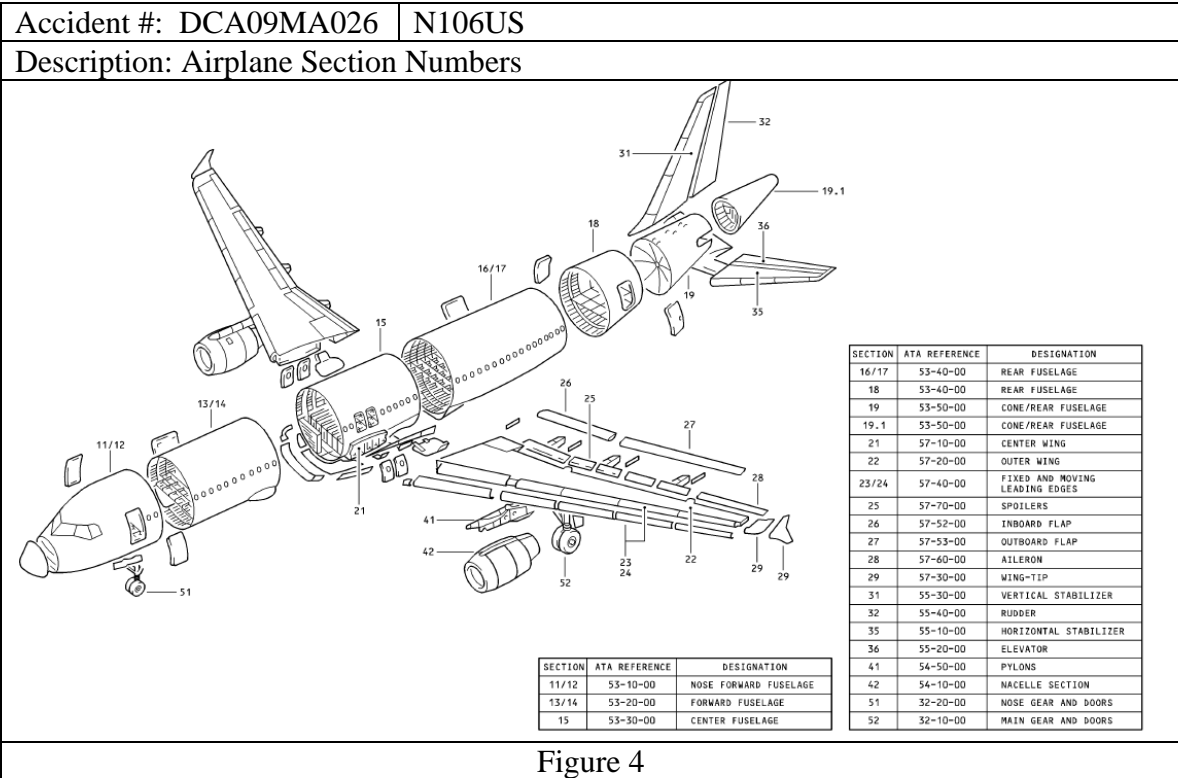
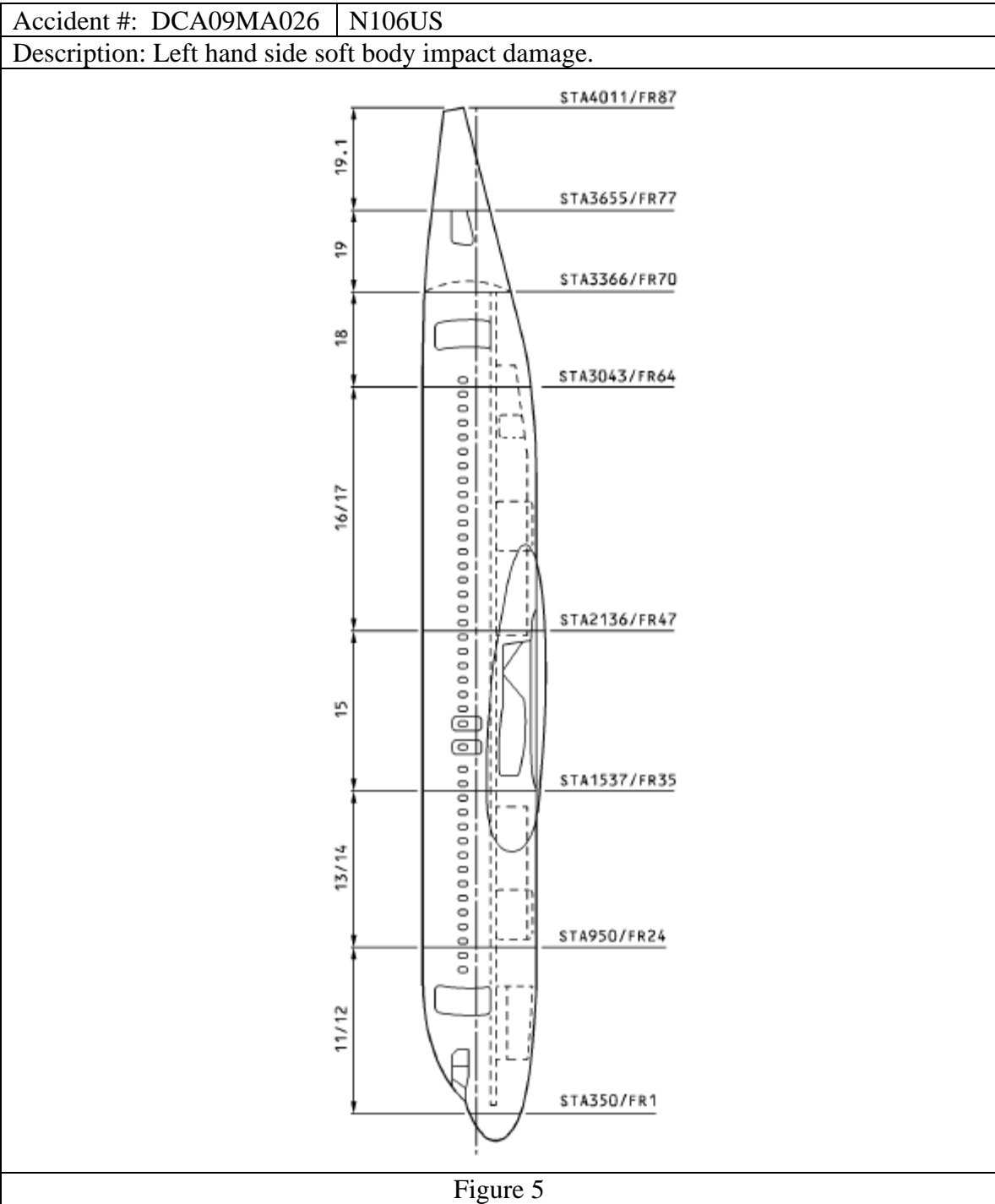
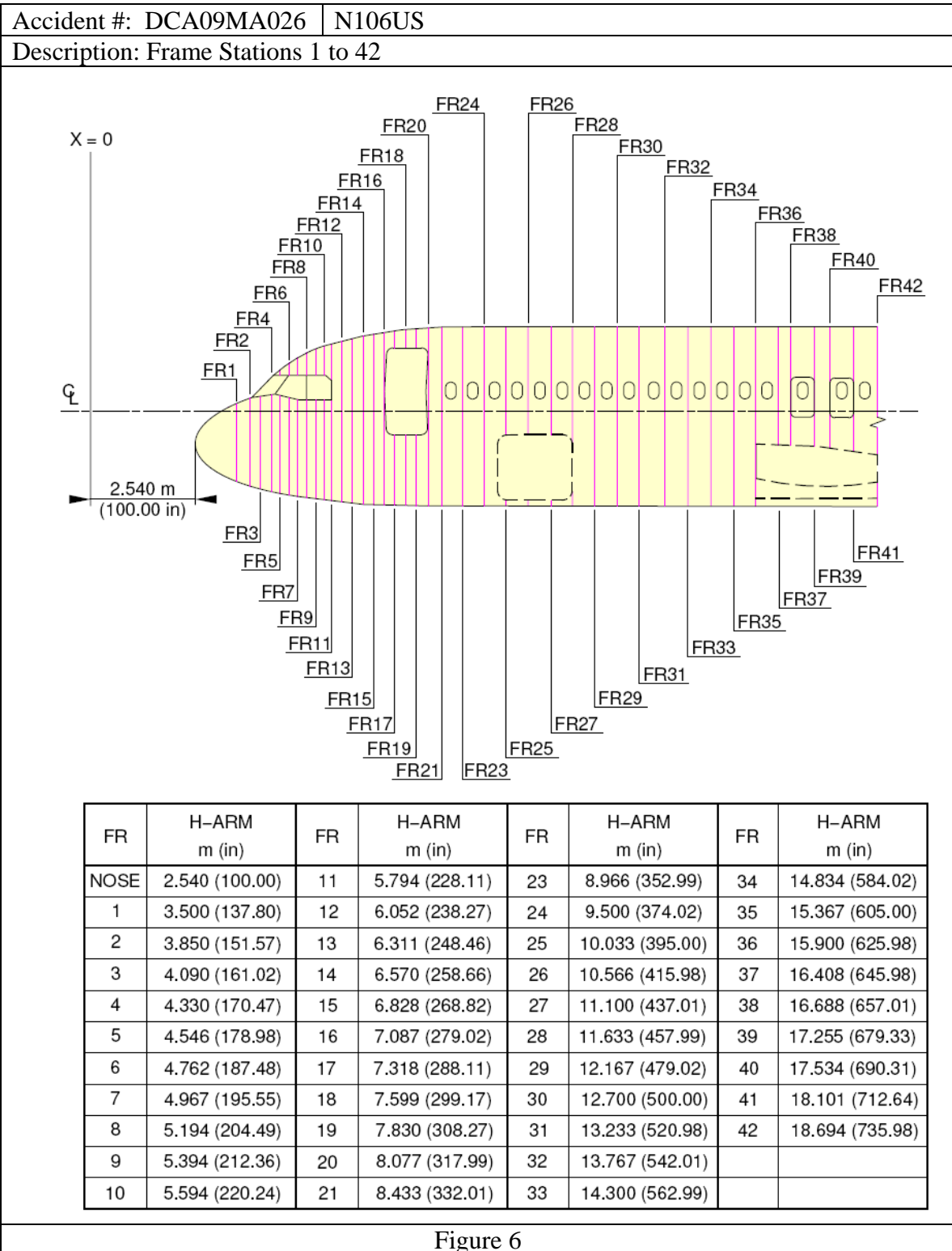

Figure 4







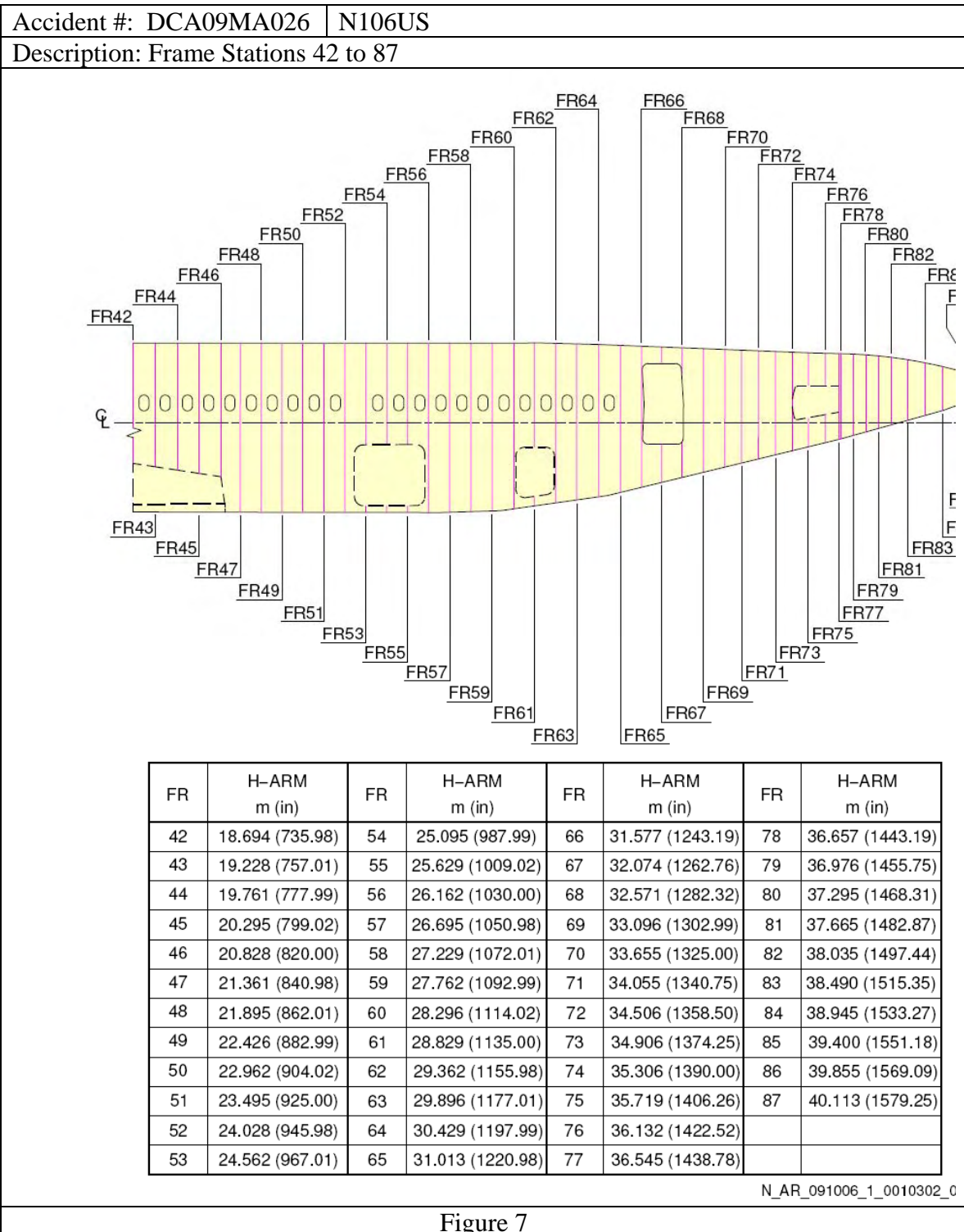

Figure 7

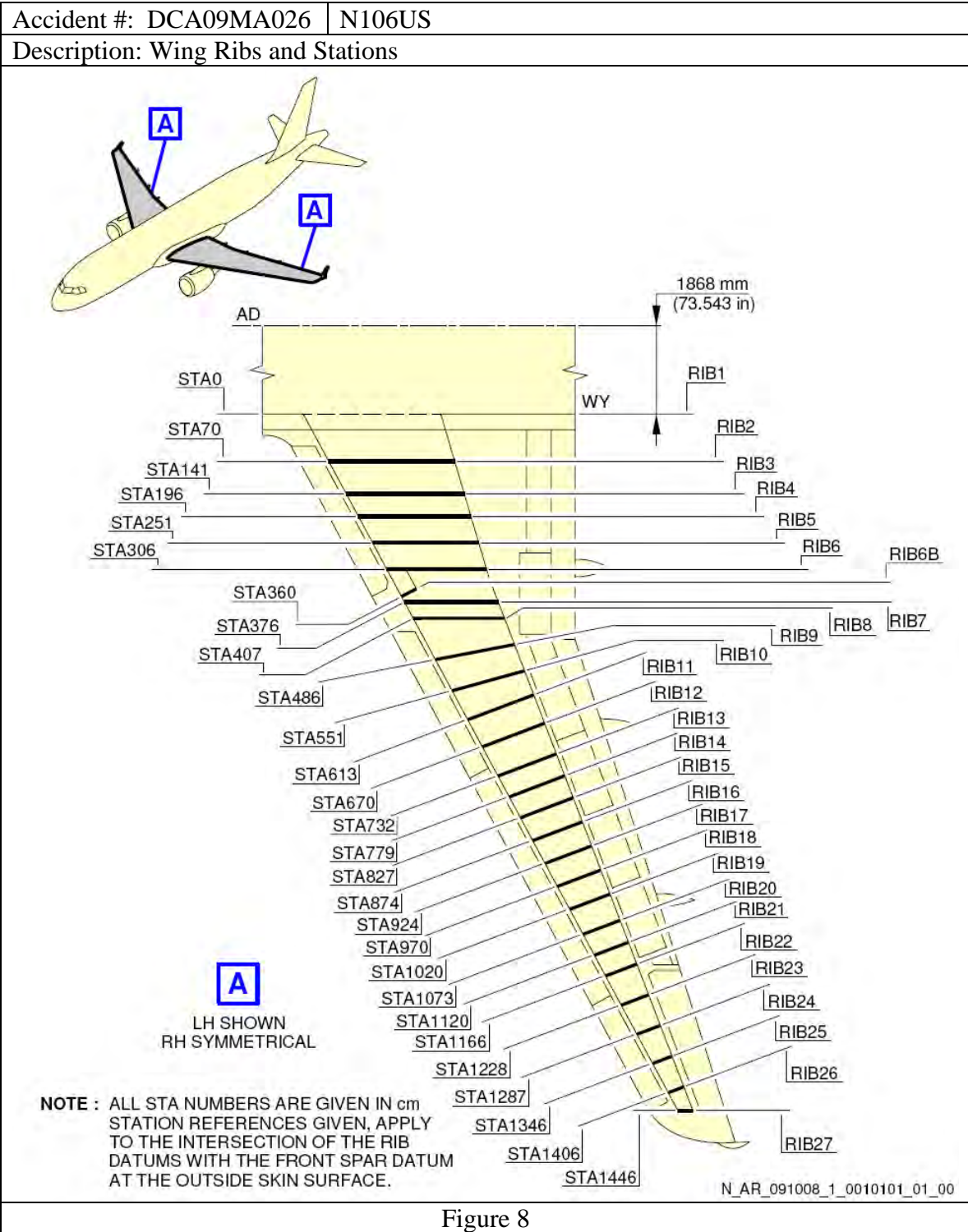
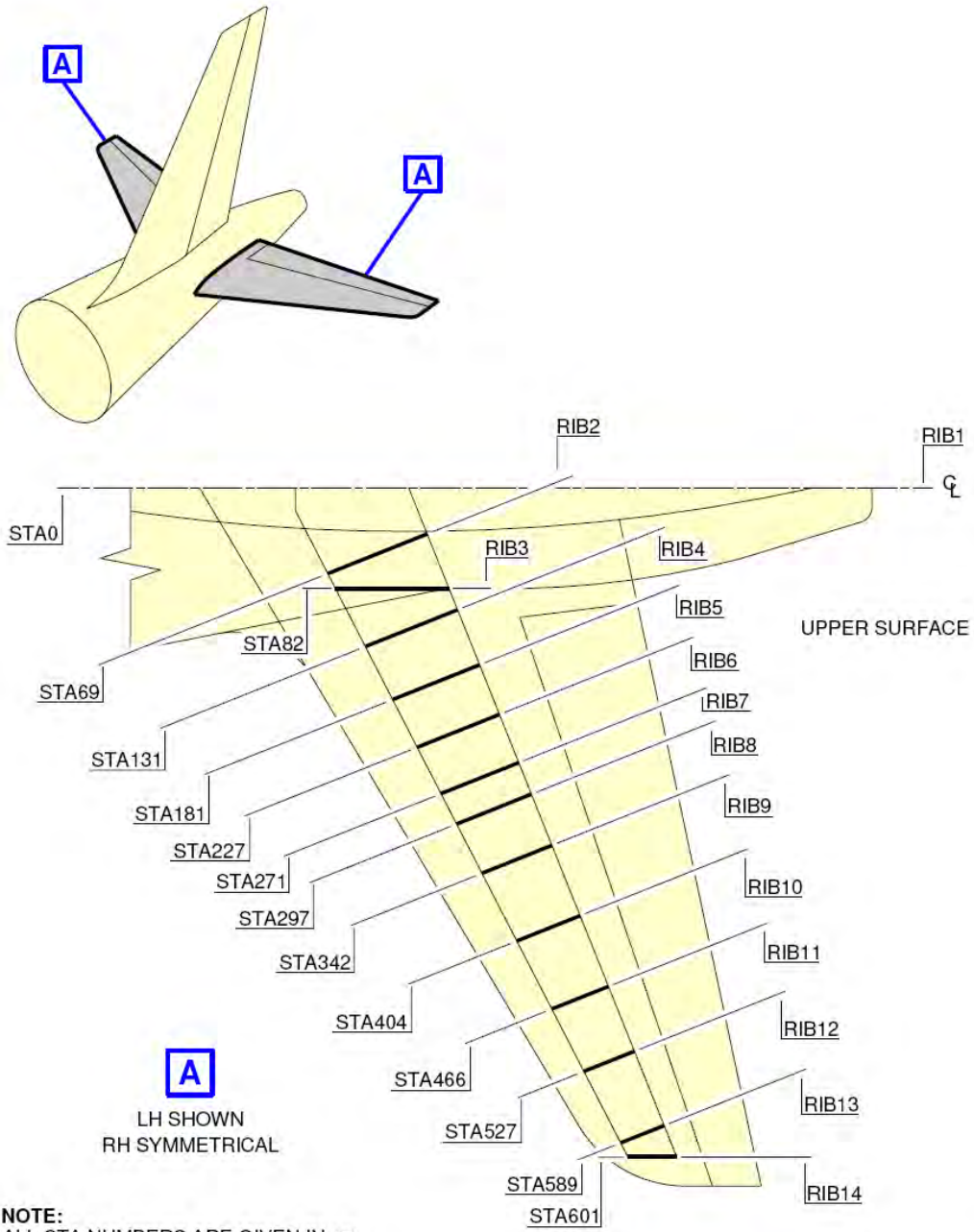

Figure 8

Accident #: DCA09MA026 | N106US

Description: Horizontal Stabilizer Ribs and Stations.



N\_AR\_091009\_1\_0010101\_01\_00

Figure 9

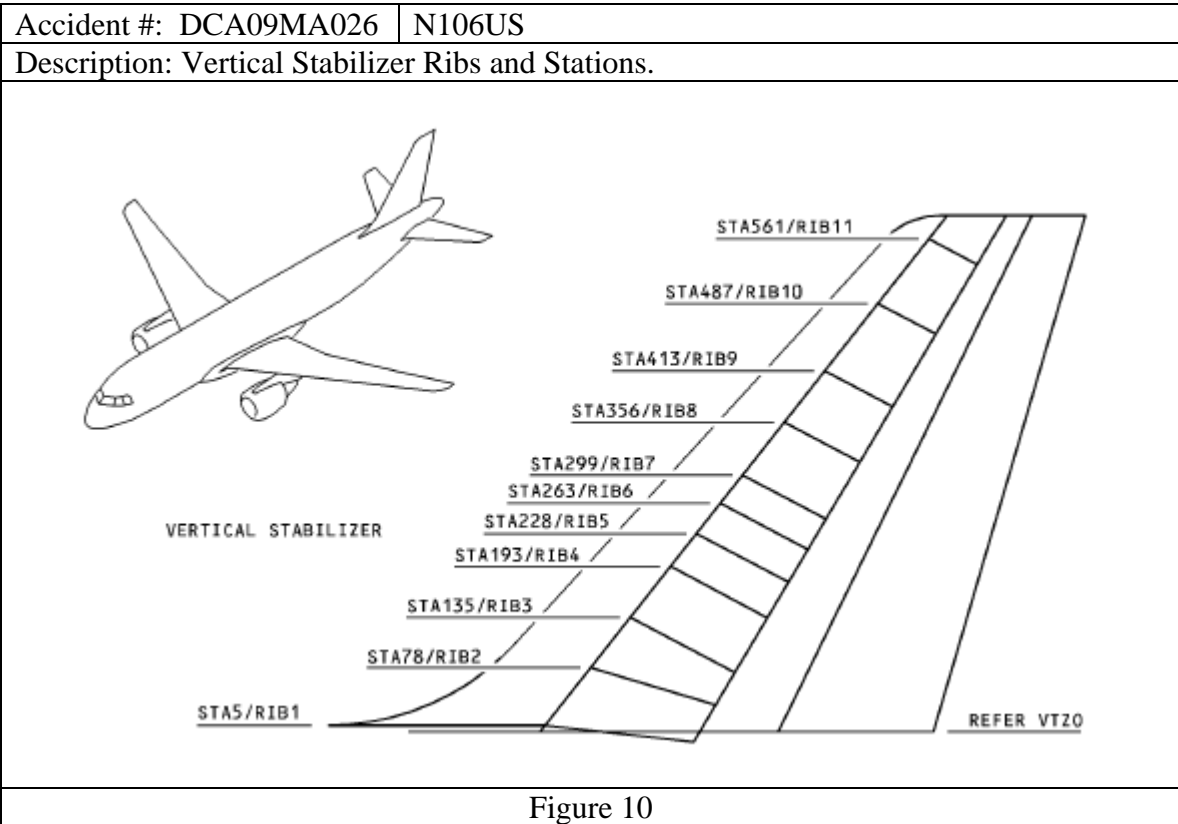

Accident #: DCA09MA026 | N106US  
 Description: Frames and Connecting Sections.

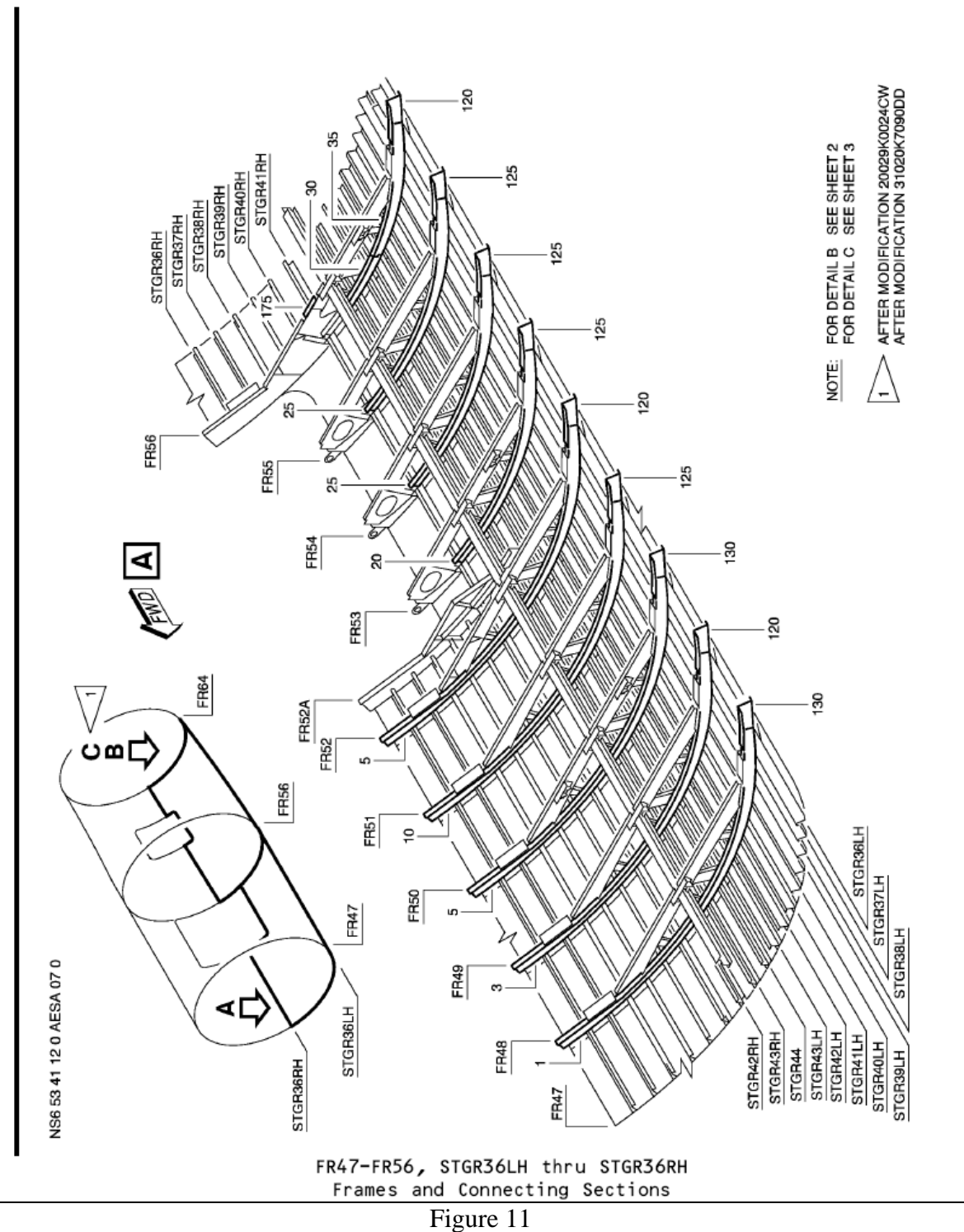
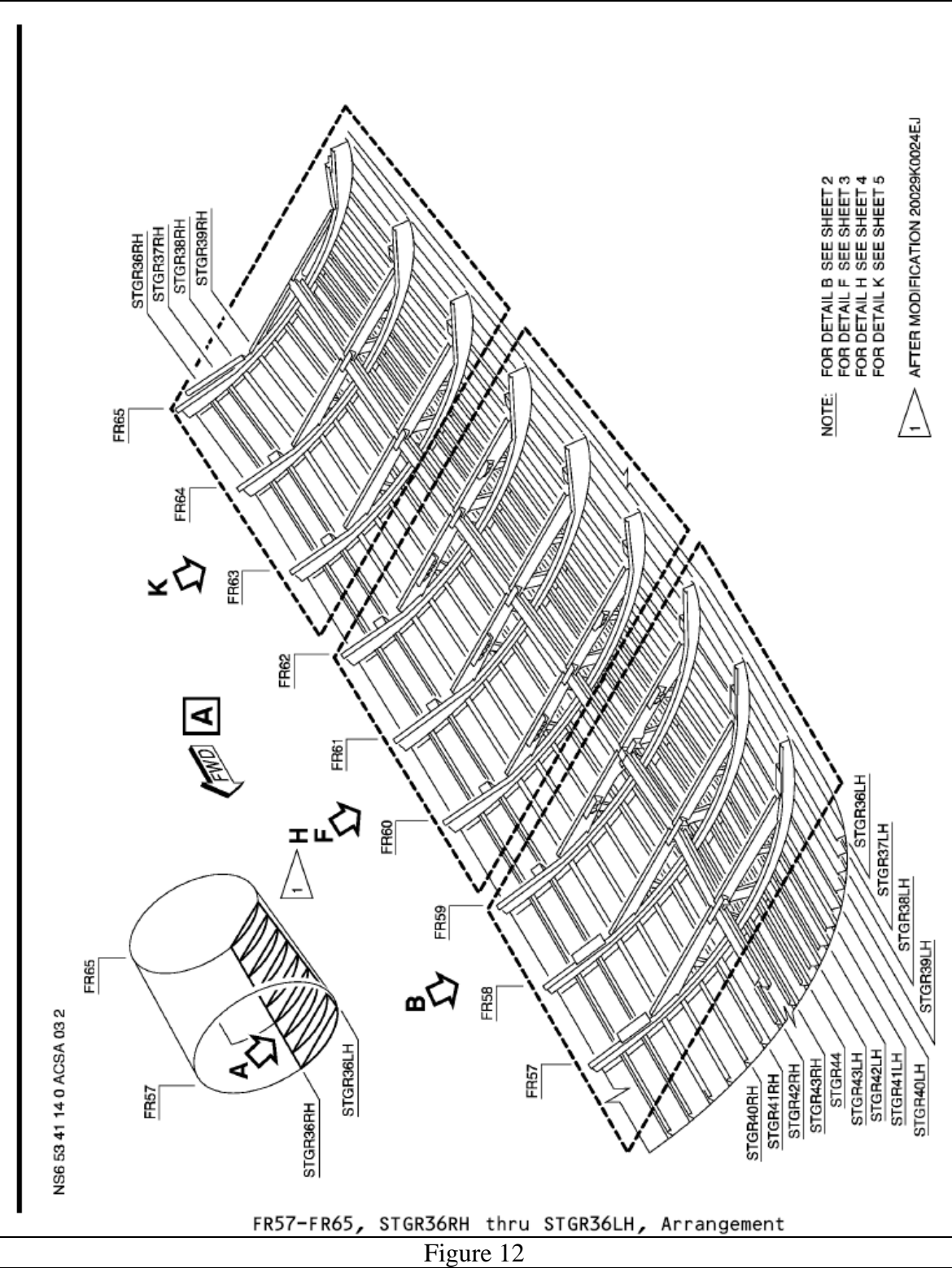
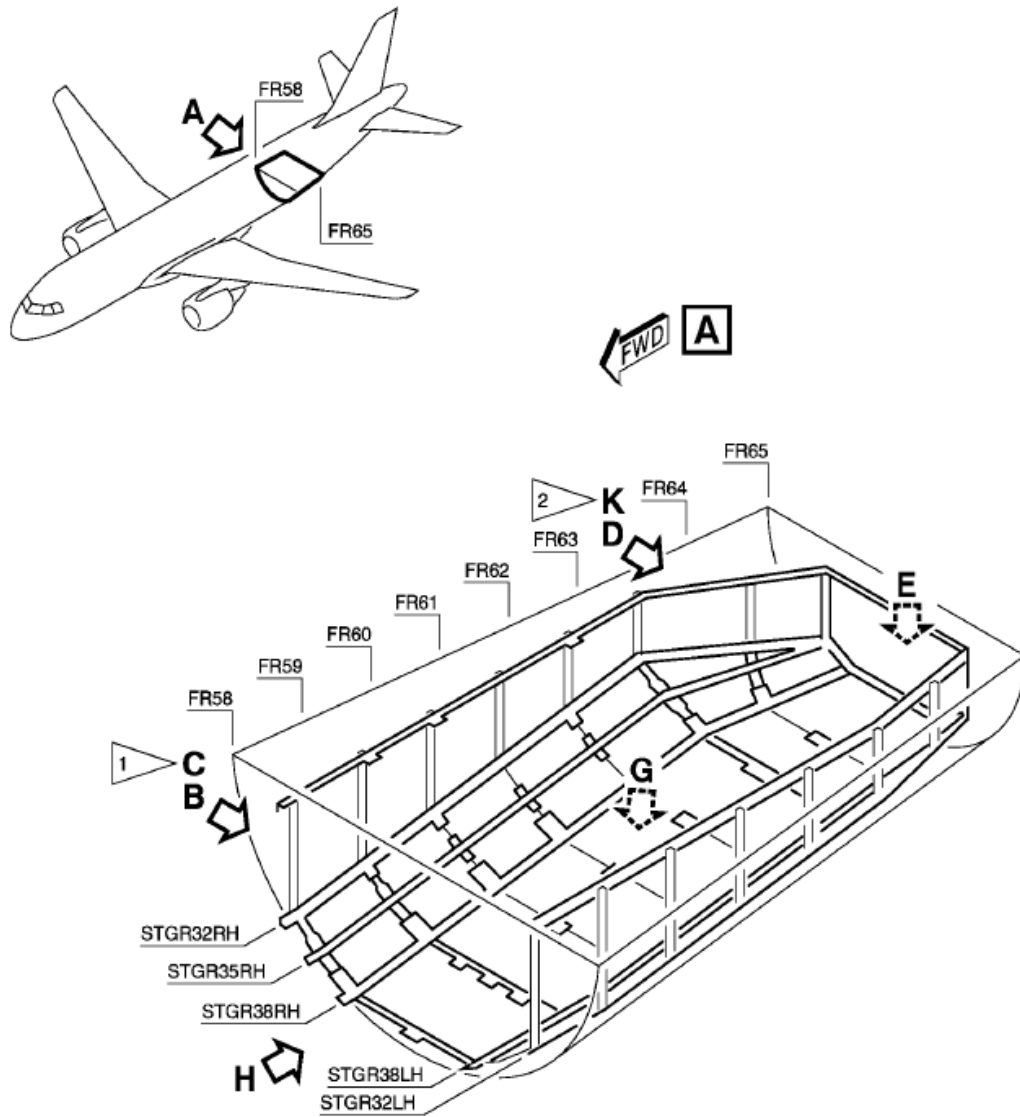

Figure 11

Accident #: DCA09MA026 | N106US  
 Description: Frames and Connecting Sections.



Accident #: DCA09MA026 | N106US  
 Description: Frames and Connecting Sections.



NS6 53 41 14 0 ANSA 03 2

**NOTE:** FOR DETAIL B SEE SHEET 2  
 FOR DETAIL C SEE SHEET 3  
 FOR DETAIL D, E SEE SHEET 4  
 FOR DETAIL G SEE SHEET 5  
 FOR DETAIL H SEE SHEET 6  
 FOR DETAIL K SEE SHEET 7

1 AFTER MODIFICATION 20029K0024  
 AFTER MODIFICATION 20365K0287N  
 2 AFTER MODIFICATION 26994K5266D  
 AFTER MODIFICATION 26371K4914A

FR58-FR65, STGR32RH thru STGR32LH  
 Arrangement

Figure 13



Accident #: DCA09MA026 | N106US

Description: Panels 8 and 10.

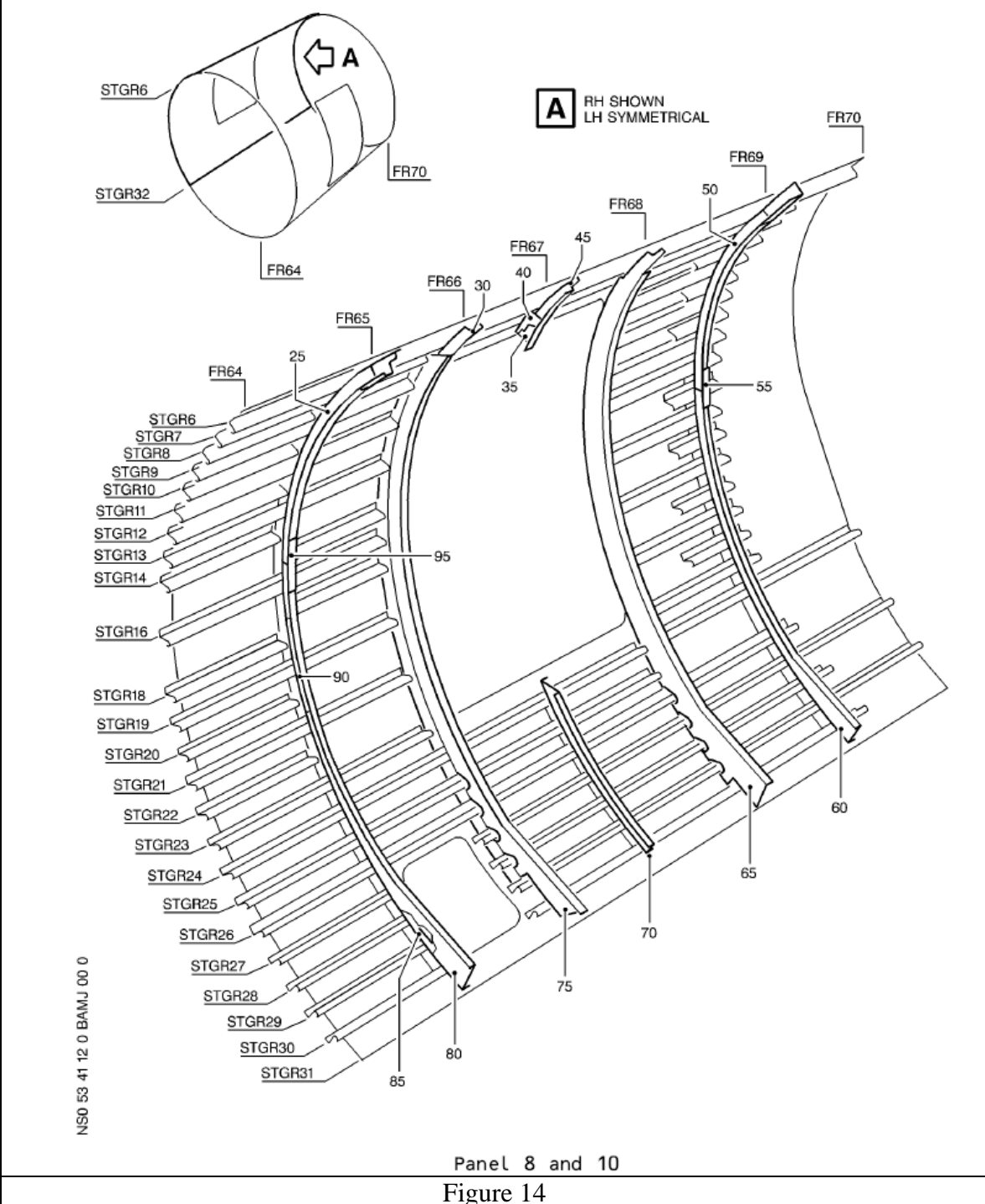



Accident #: DCA09MA026 | N106US

Description: Panel 9.

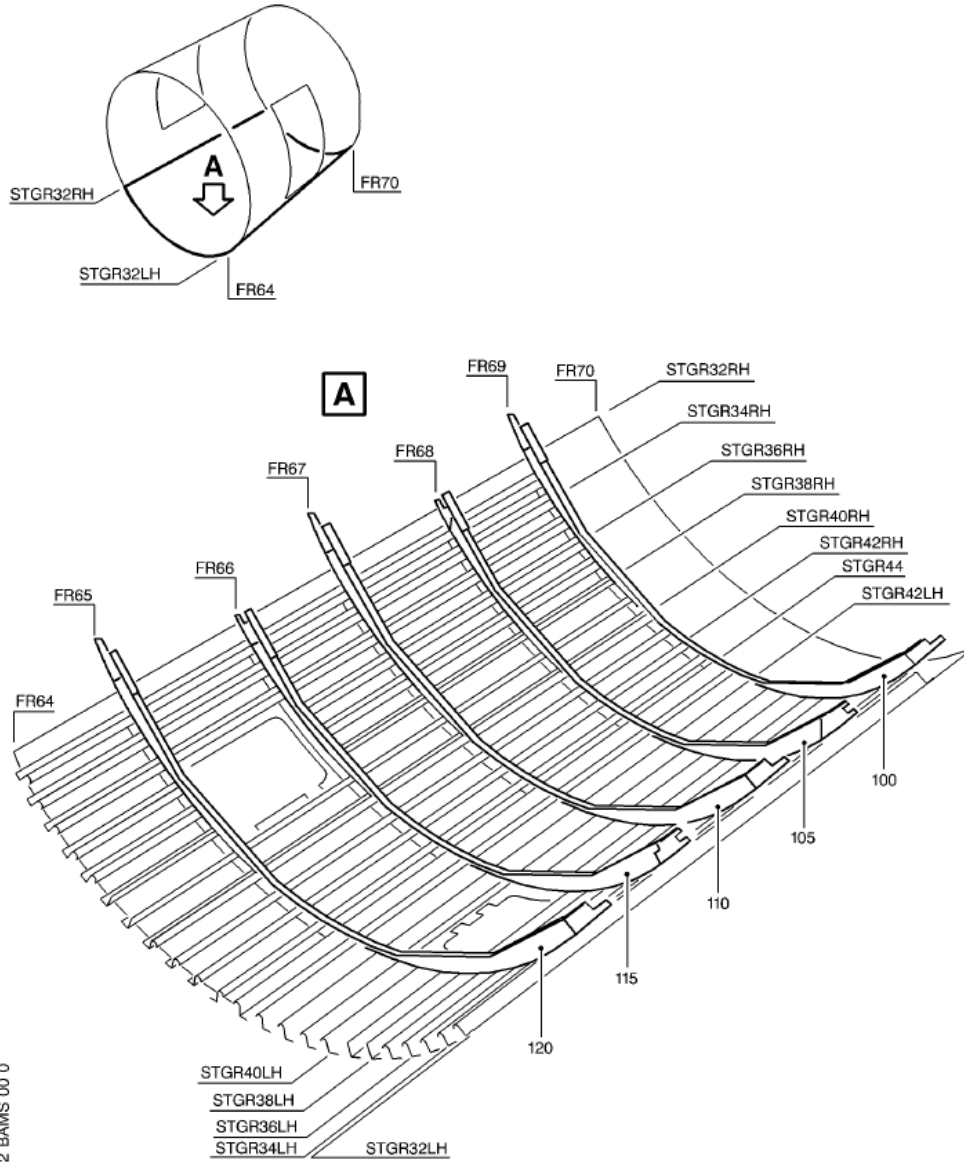

Panel 9

Figure 15



Accident #: DCA09MA026 | N106US

Description: Aft Pressure Bulkhead.

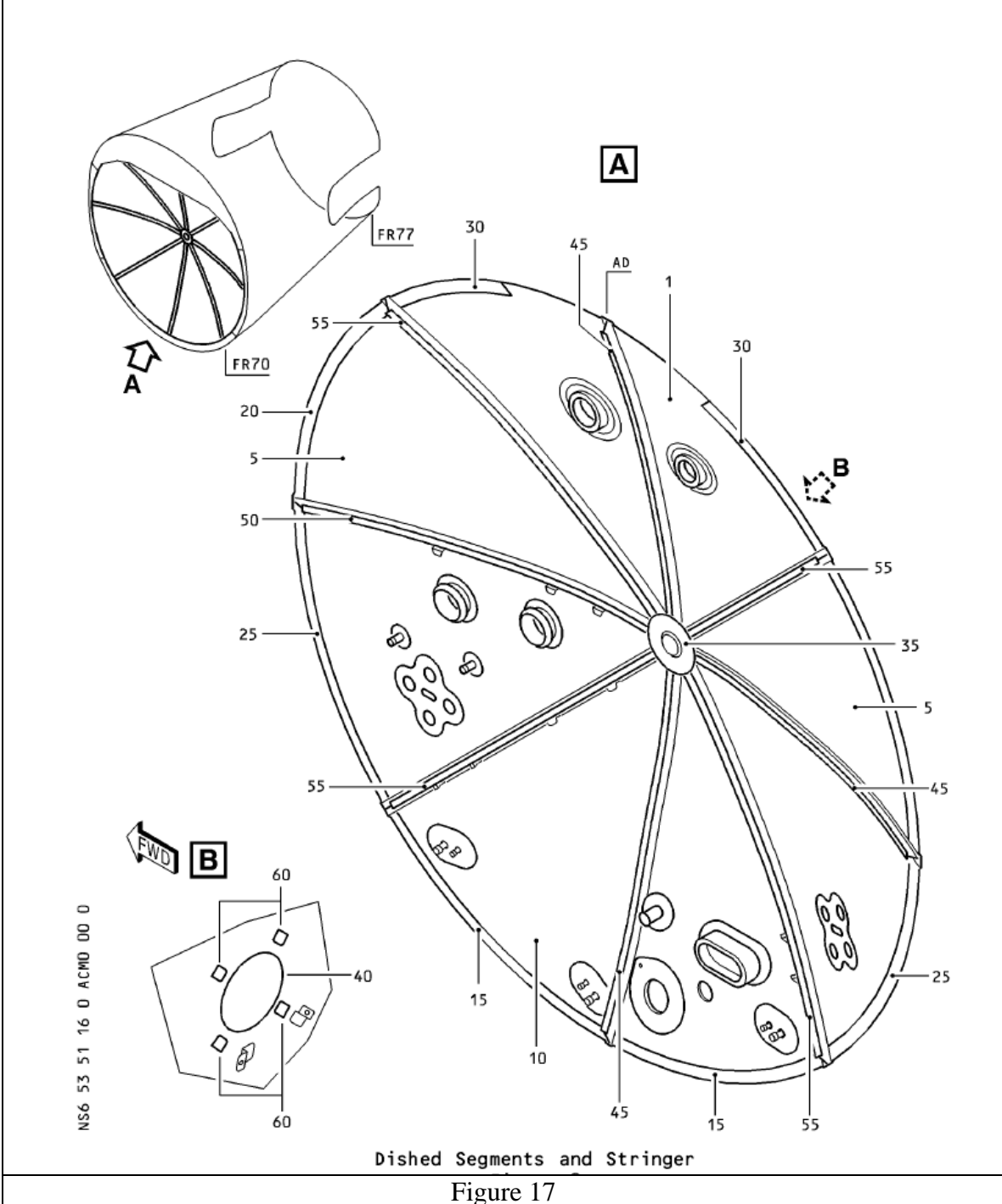

Accident #: DCA09MA026 | N106US

Description: Panel 6.

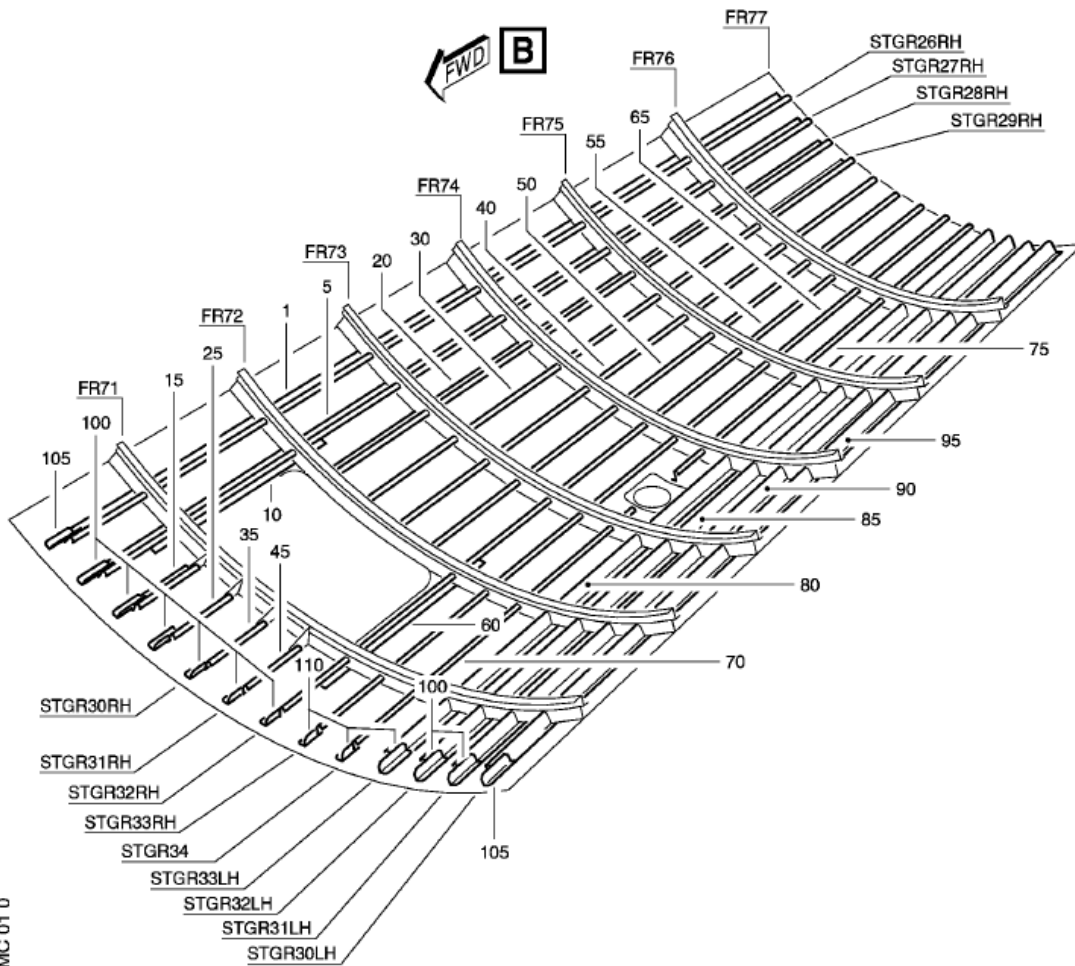

NS6 53 51 13 0 AEMC 01 0

EFFECTIVITY: AFTER MODIFICATION 21817K1936A

Stringers and Couplings - Panel 6

Figure 18

Accident #: DCA09MA026 | N106US

Description: Side Shell Stiffening Structure.

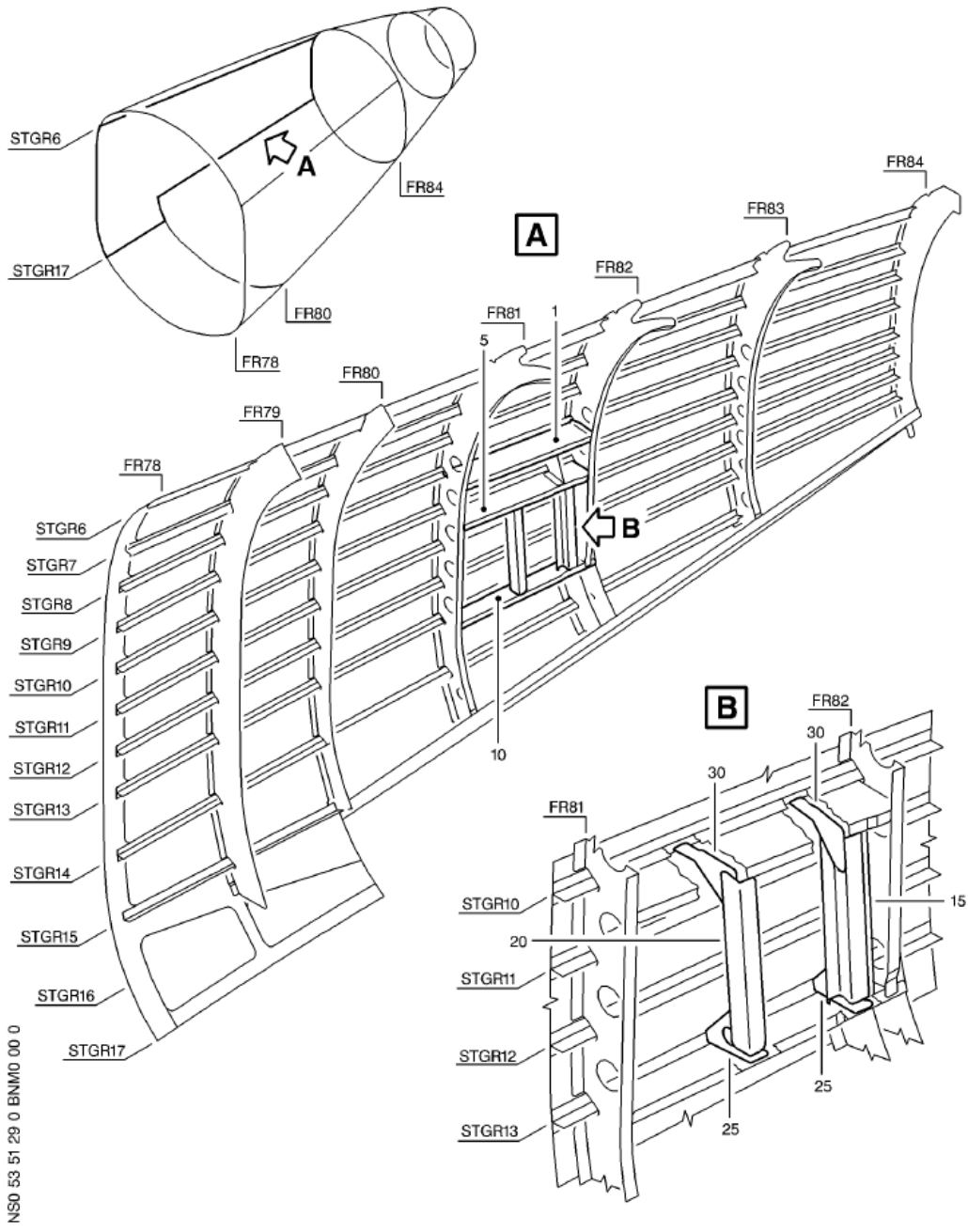

NS0 53 51 29 0 BNM0 00 0

Side Shell RH,FR81-FR82, Stiffening Structure

Figure 19

Accident #: DCA09MA026 | N106US

Description: Panel 11 LH.

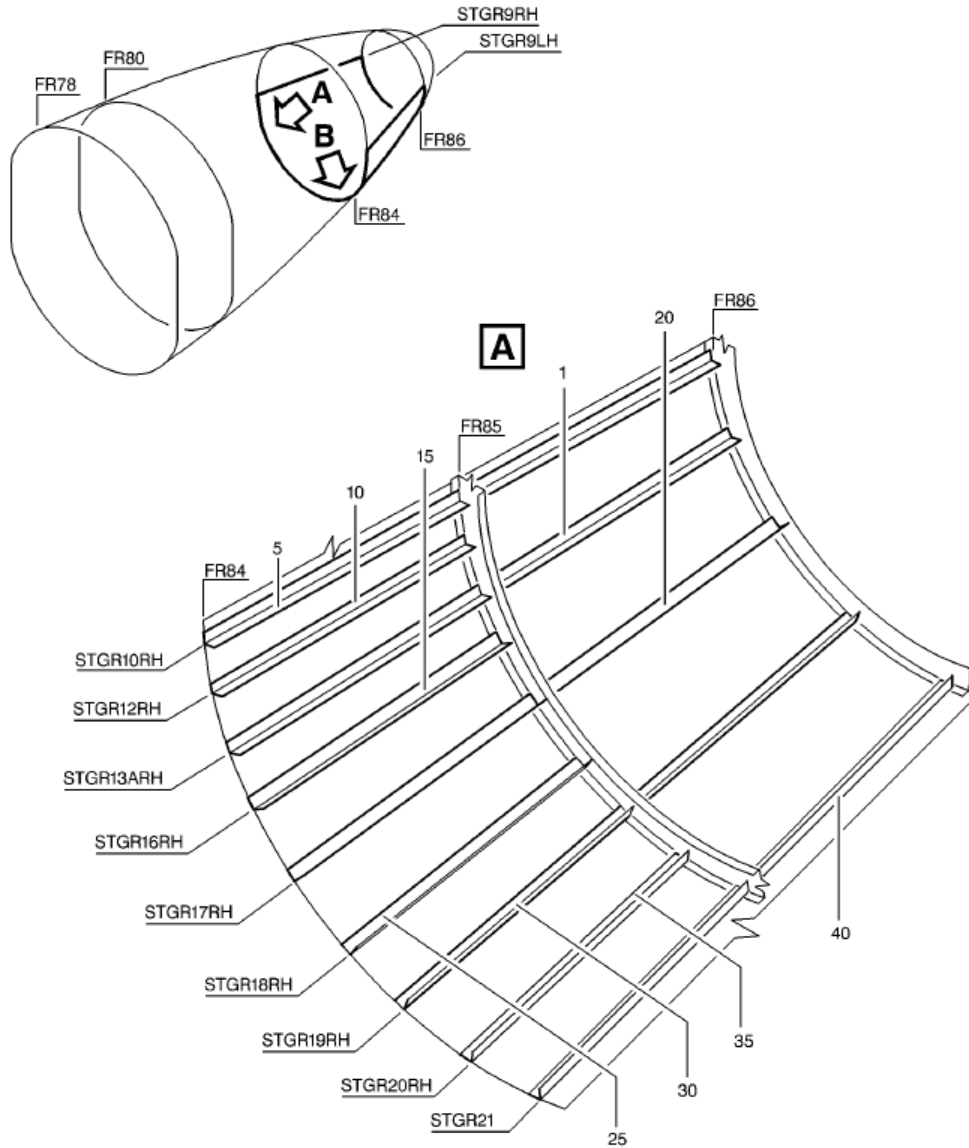

NSO 53 51 13 0 AQMA 00 0

NOTE: FOR DETAIL B SEE SHEET 2

Panel 11

Figure 20

