

# ENGINE TO STRUT ATTACHMENT

## STRUT NO. 1

FORWARD ENGINE MOUNT BULKHEAD (INTACT)

FULLY ATTACHED TO STRUT BOX

REAR ENGINE MOUNT BULKHEAD (FULLY INTACT)

REAR ENGINE MOUNT BULKHEAD (FULLY INTACT)

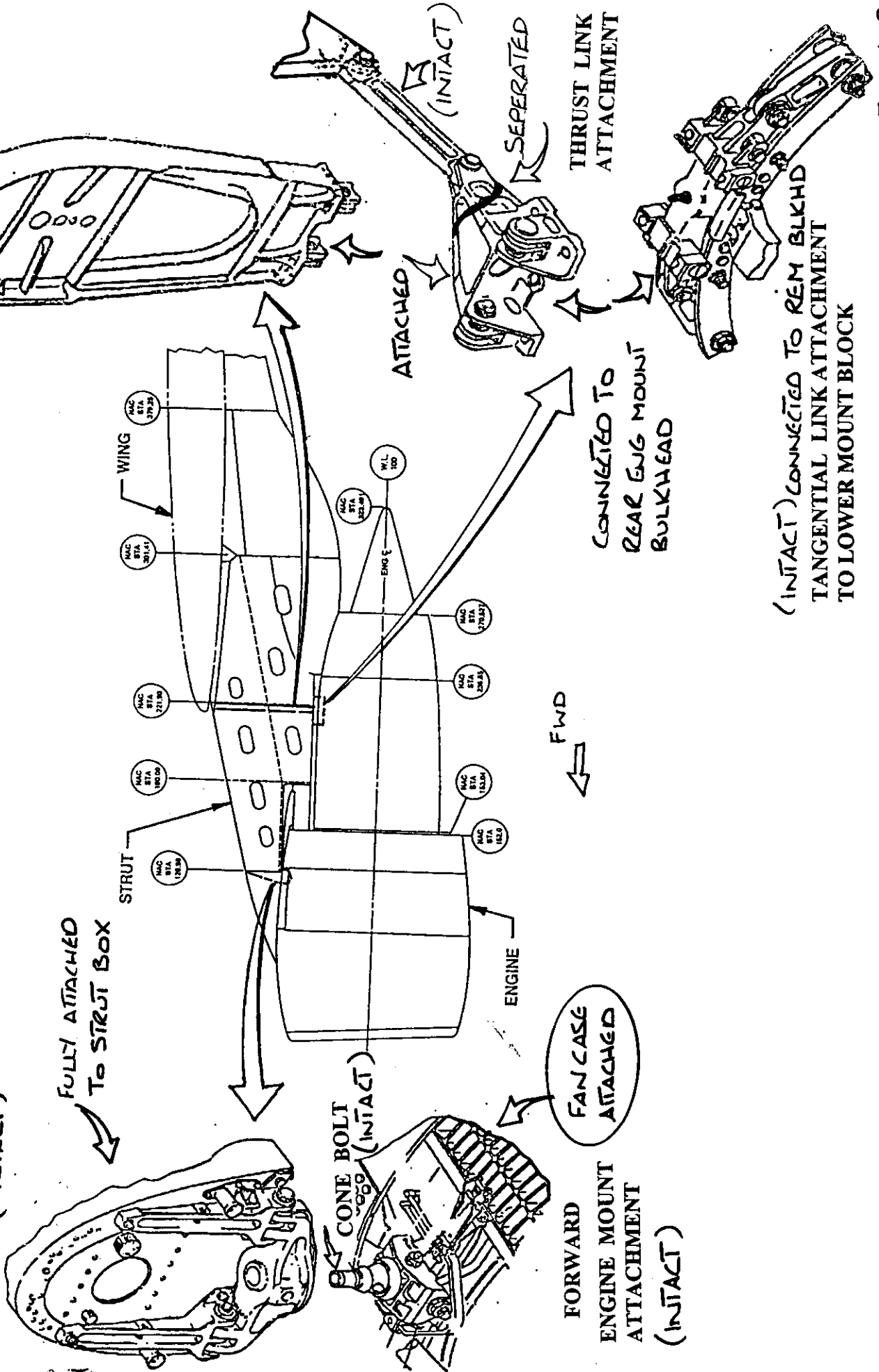

FIG 1-3

Tom Todman  
FAA 12-9-96

Dennis Denton  
12-4-96

50 GREEN 01-23-97  
ALPA

Profficiency  
Tel 12-9-96

K. Dean

# Strut-to-Wing Connections FUSE BOLT

## STRUT 1

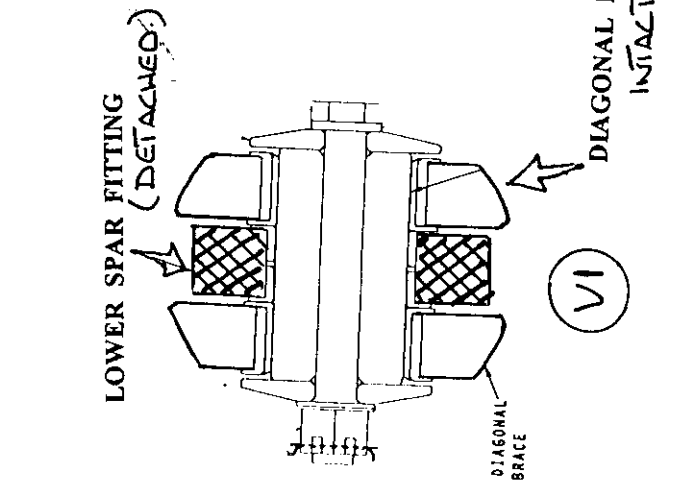
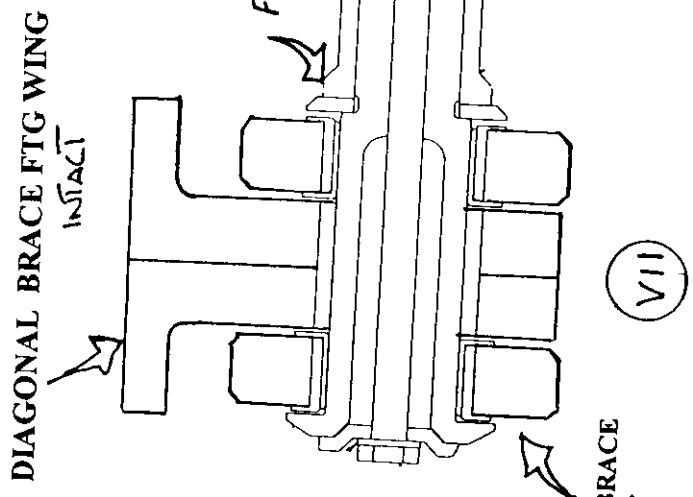
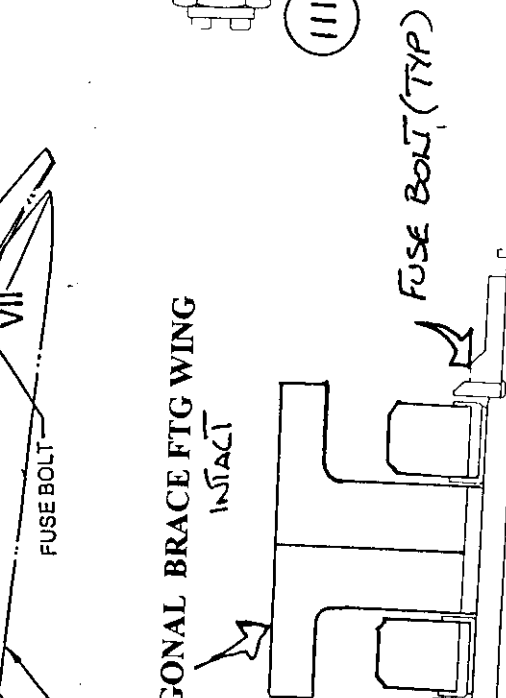
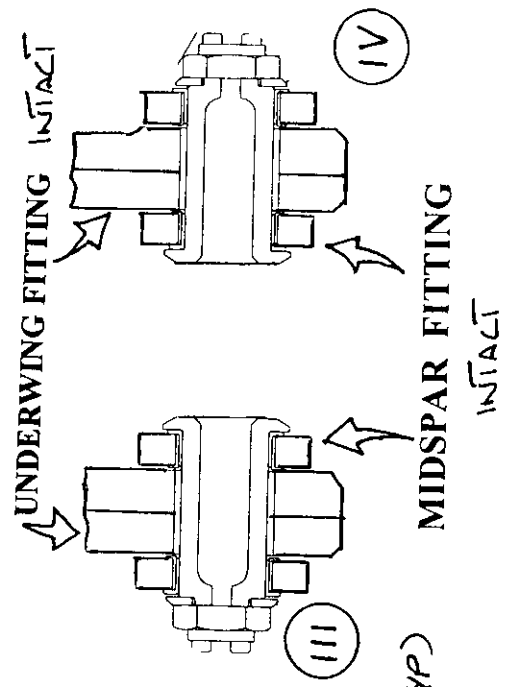
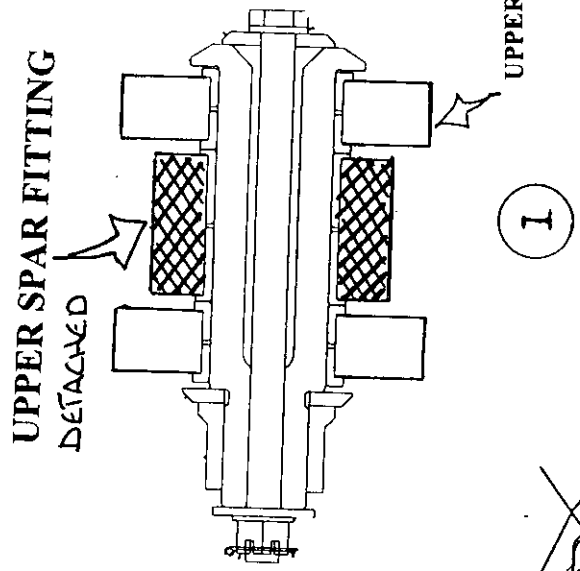
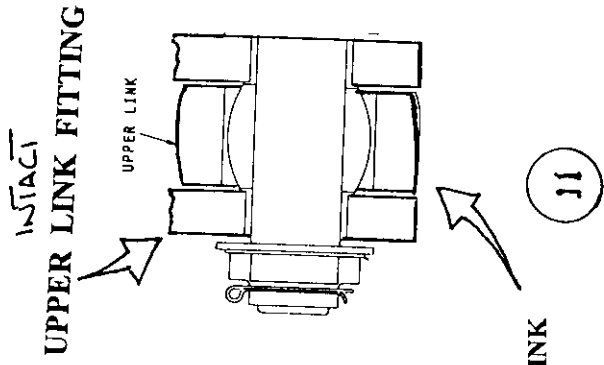
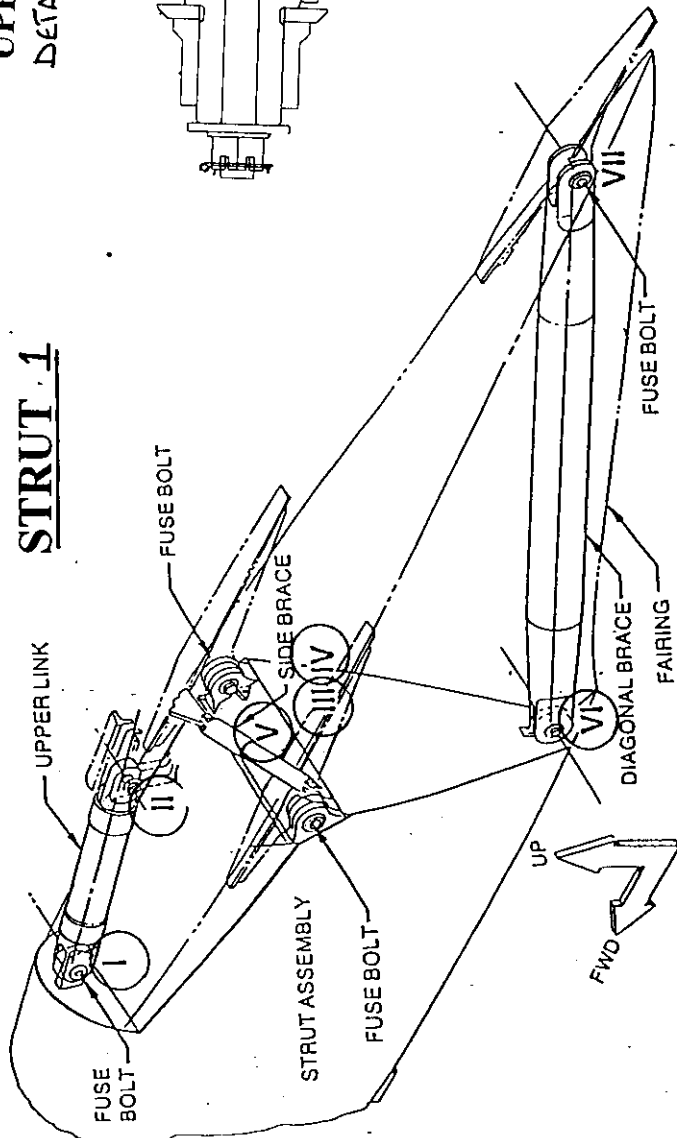



-  ATTACHED TO FUSE BOLT
-  DETACHED FROM FUSE BOLT

FIG 1-4

Tom Todaro FAR 12-9-96  
 Dennis Santiago 12-9-96

SO GAREN 01-23-97  
 ALPA

Tom Todaro K. Dean  
 FAR 12-8-96