

**APPENDIX A**

**SECTION A7 (ENGINE STRUTS**

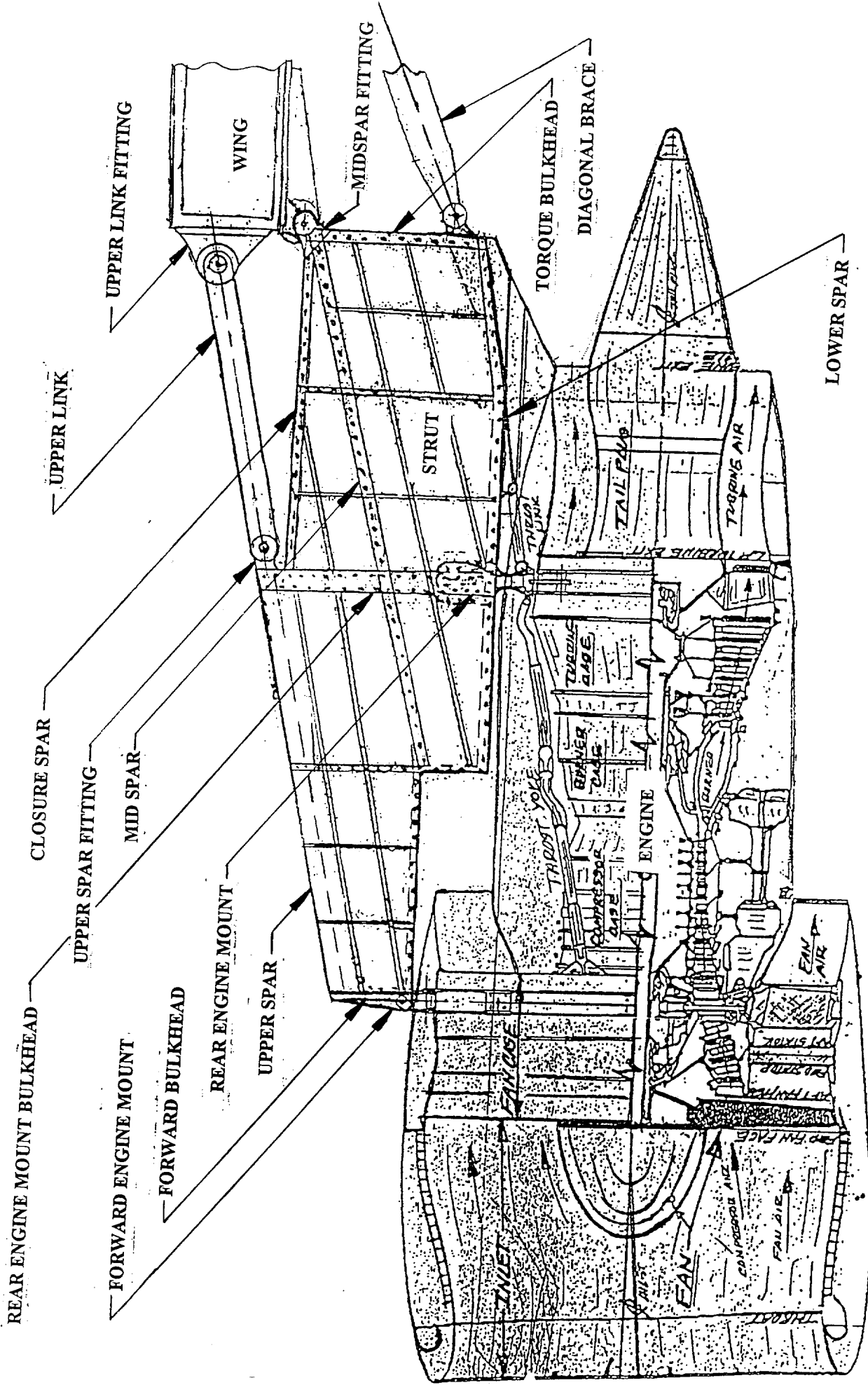

STRUT ASSEMBLY DIAGRAM

# Strut-to-Wing Connections

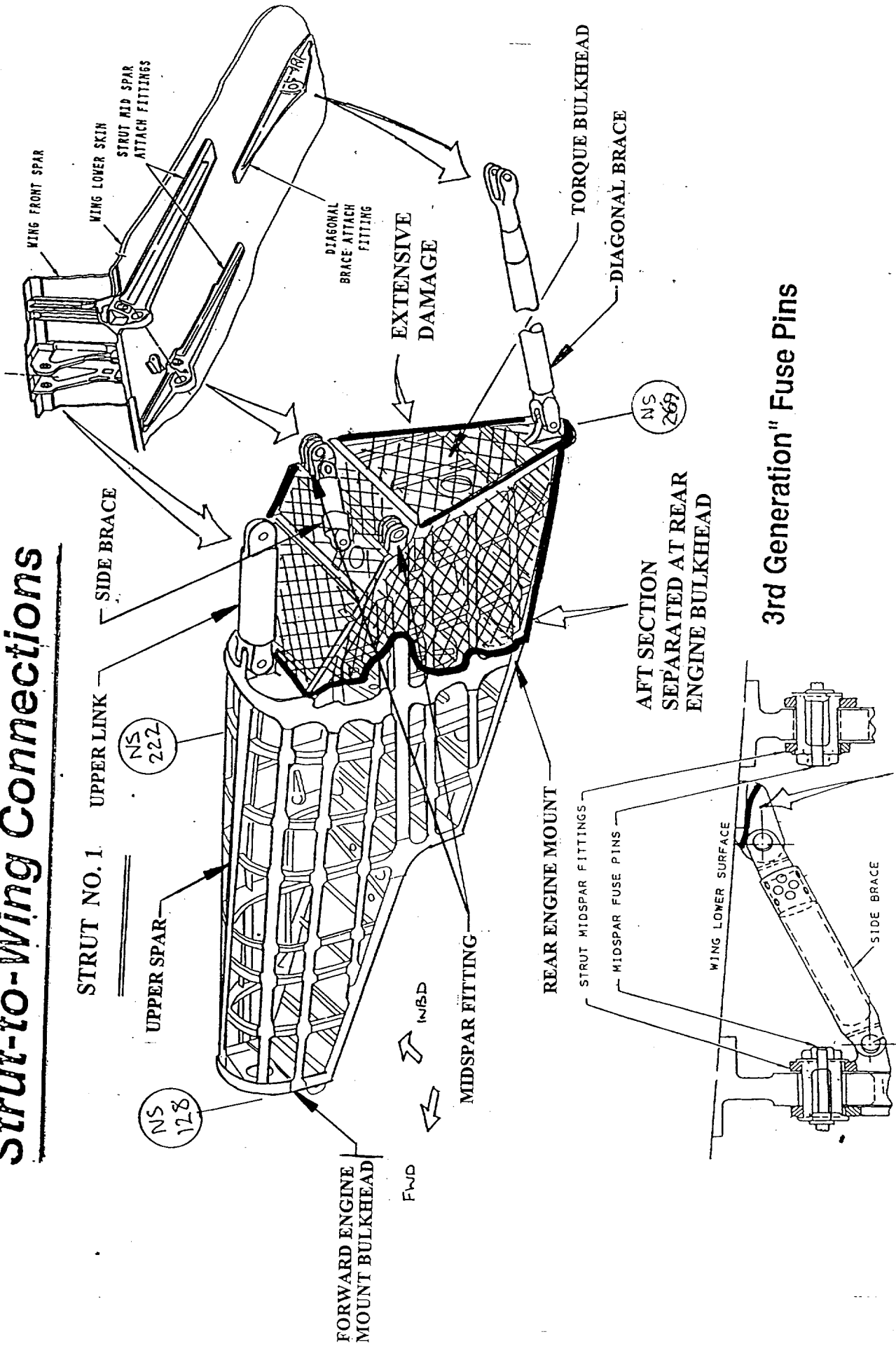

**SIDE BRACE ATTACHMENT SEPARATED AT WING CONNECT (DUCTILE FRACTURE)**

STRUT-TO-WING CONNECTIONS    STRUT NO. 1

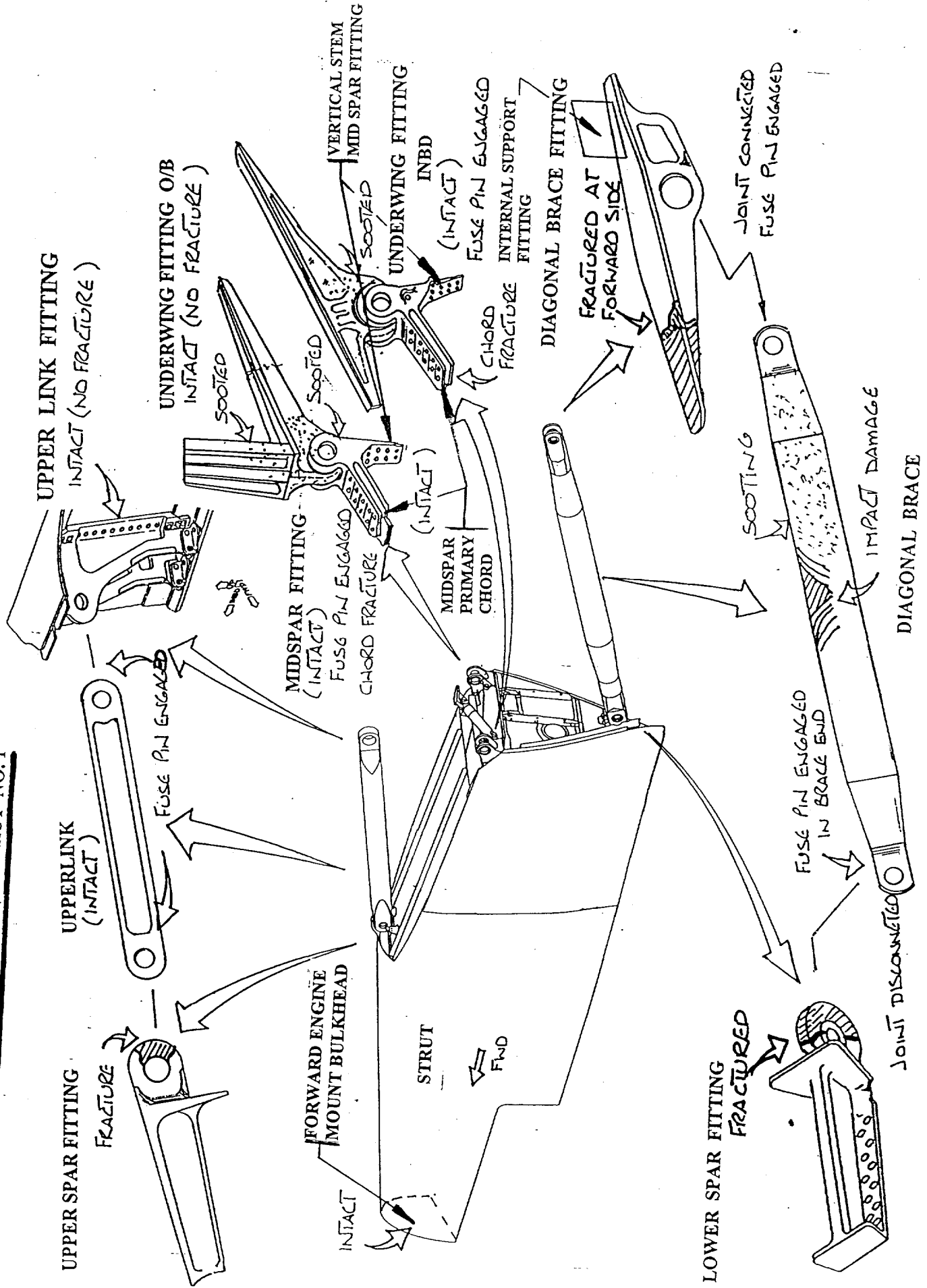

# ENGINE TO STRUT ATTACHMENT

## STRUT NO. 1

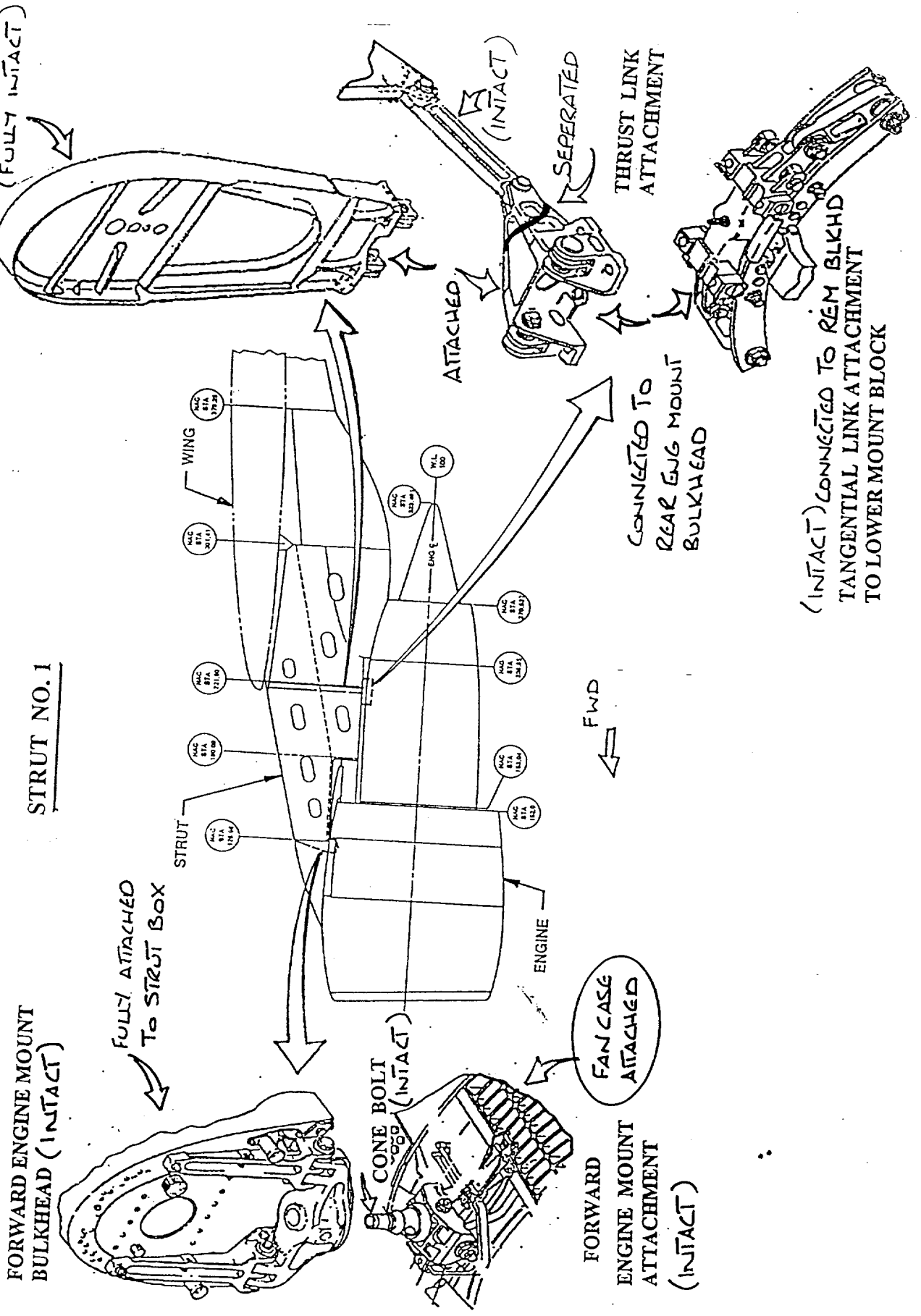

# Strut-to-Wing Connections FUSE BOLT

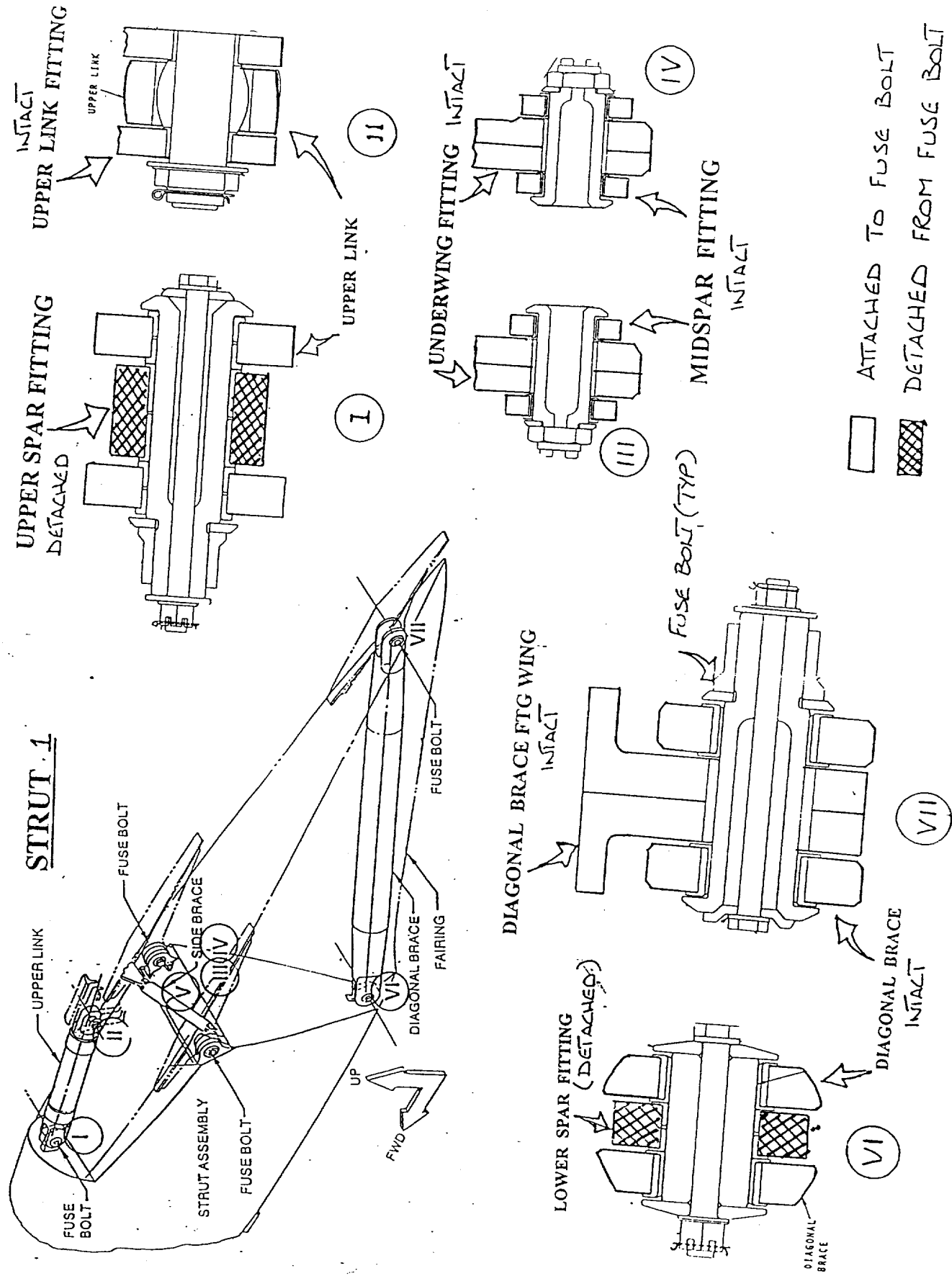

# STRUT - TO - WING CONNECTIONS

STRUT No. 2

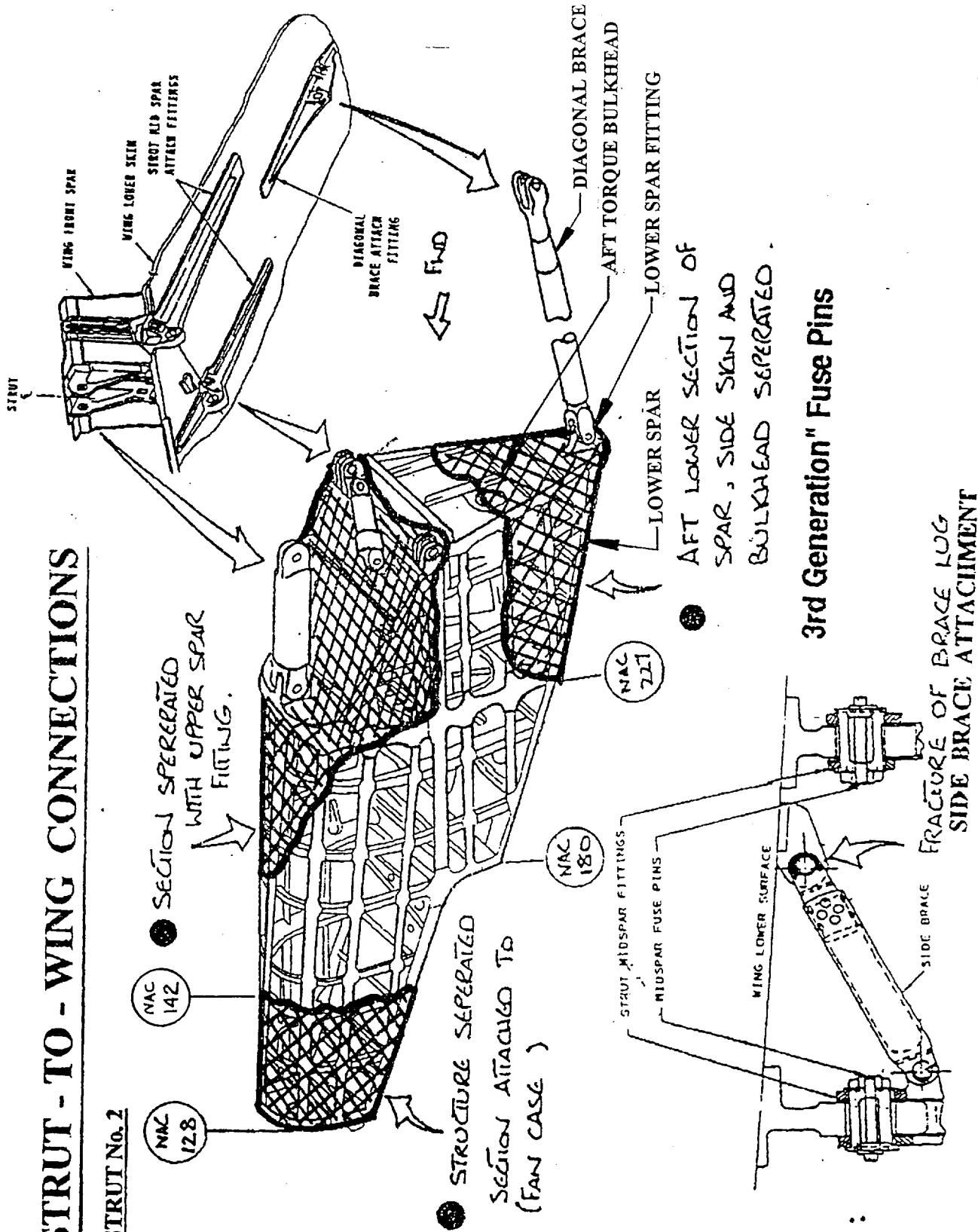

3rd Generation" Fuse Pins

# STRUT-TO-WING CONNECTIONS STRUT NO. 2

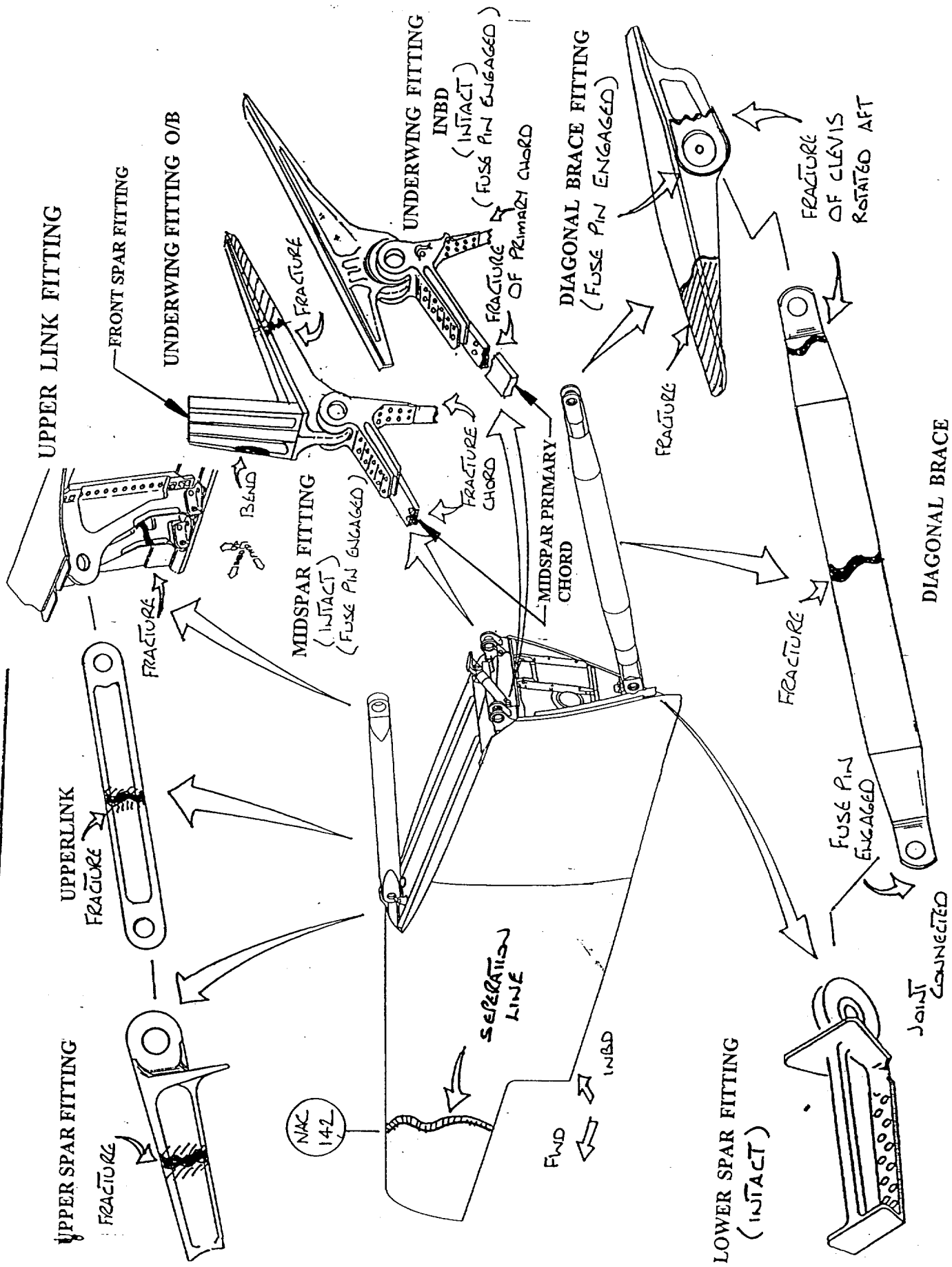



# ENGINE TO STRUT ATTACHMENT

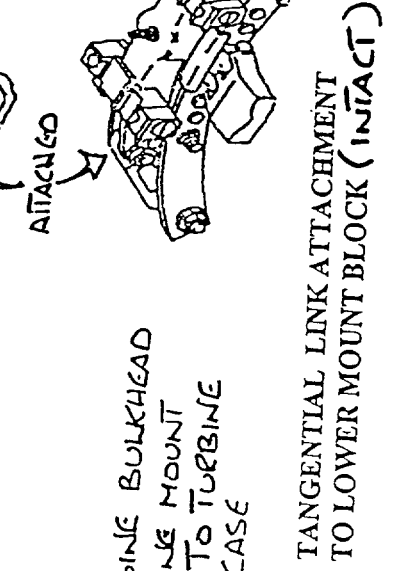
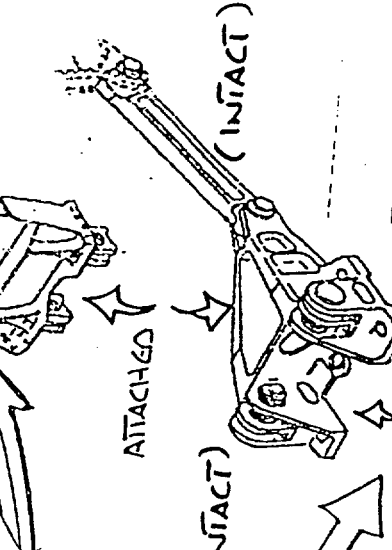
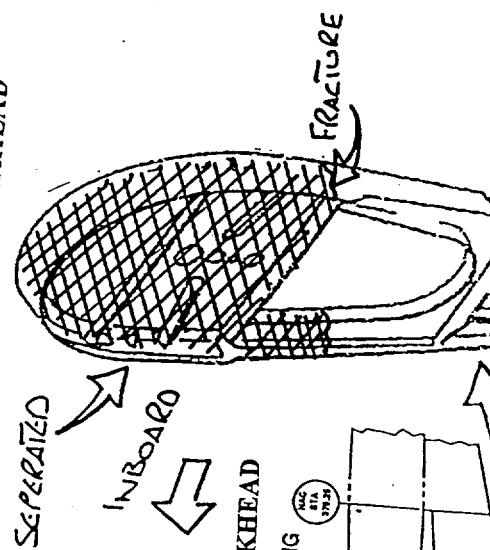
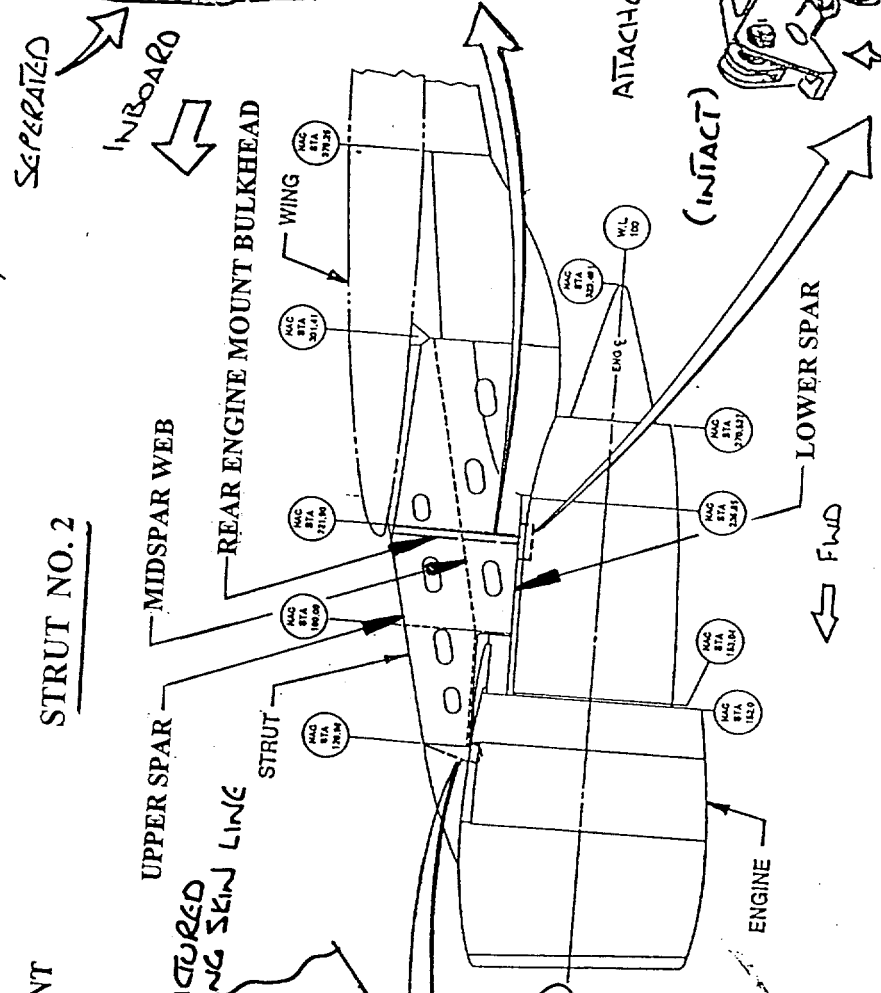
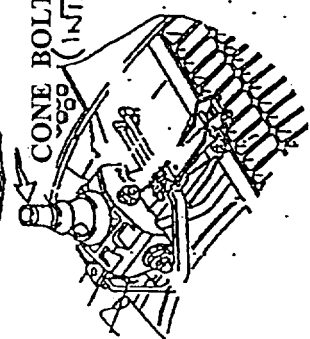
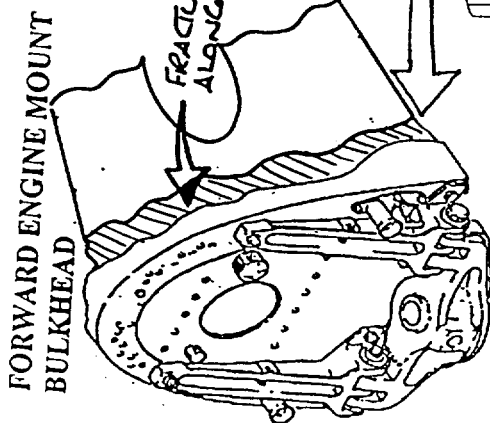

REAR ENGINE BULKHEAD AND ENGINE MOUNT ATTACHED TO TURBINE EXHAUST CASE

# STRUT - TO - WING CONNECTIONS

STRUT NO. 3.

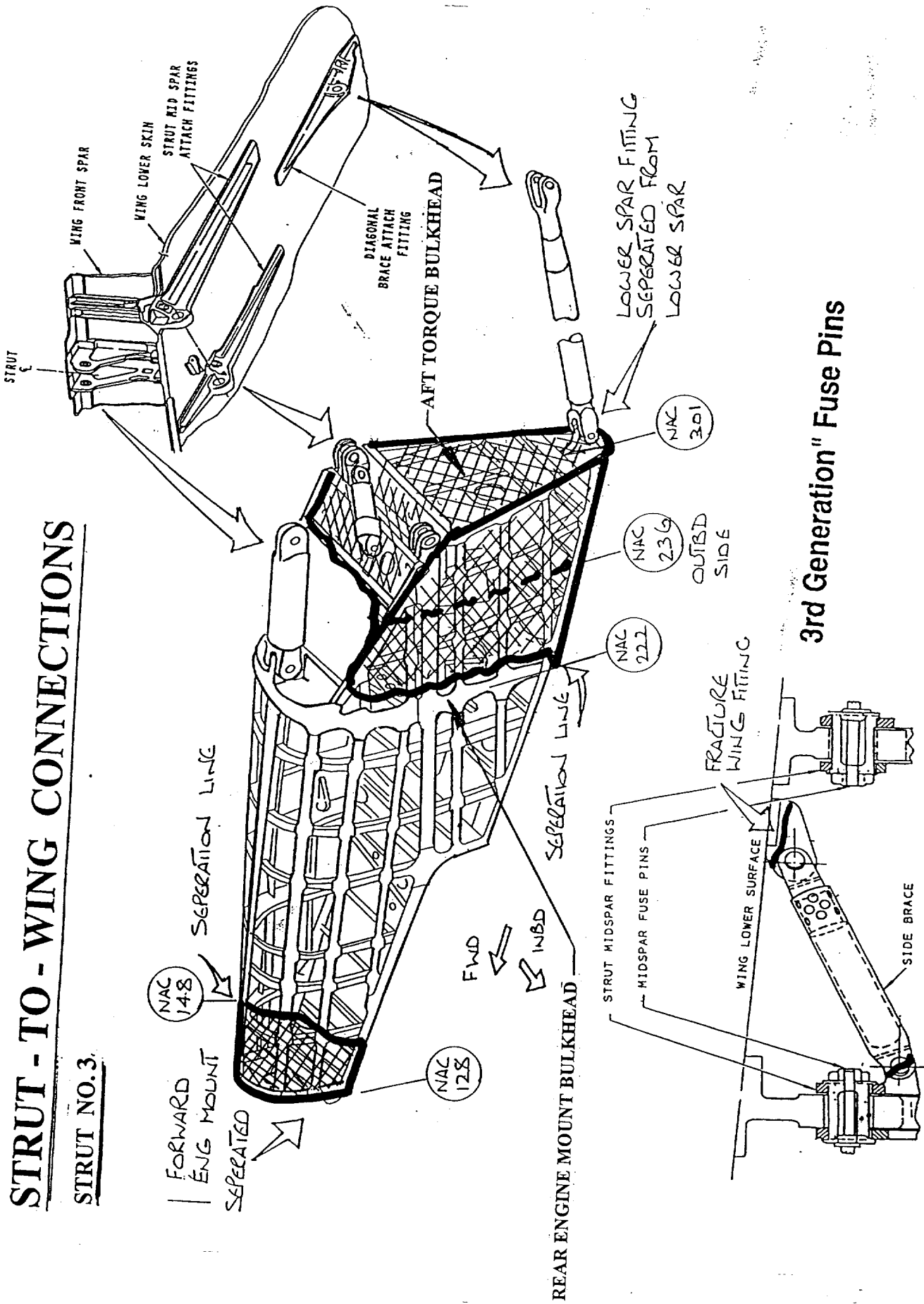

3rd Generation Fuse Pins

SIDE BRACE ATTACHMENT

FRATURE OF MIDSPAR FITTING

SL... I-TO-WING CONNECTIONS STRUT NO. 3

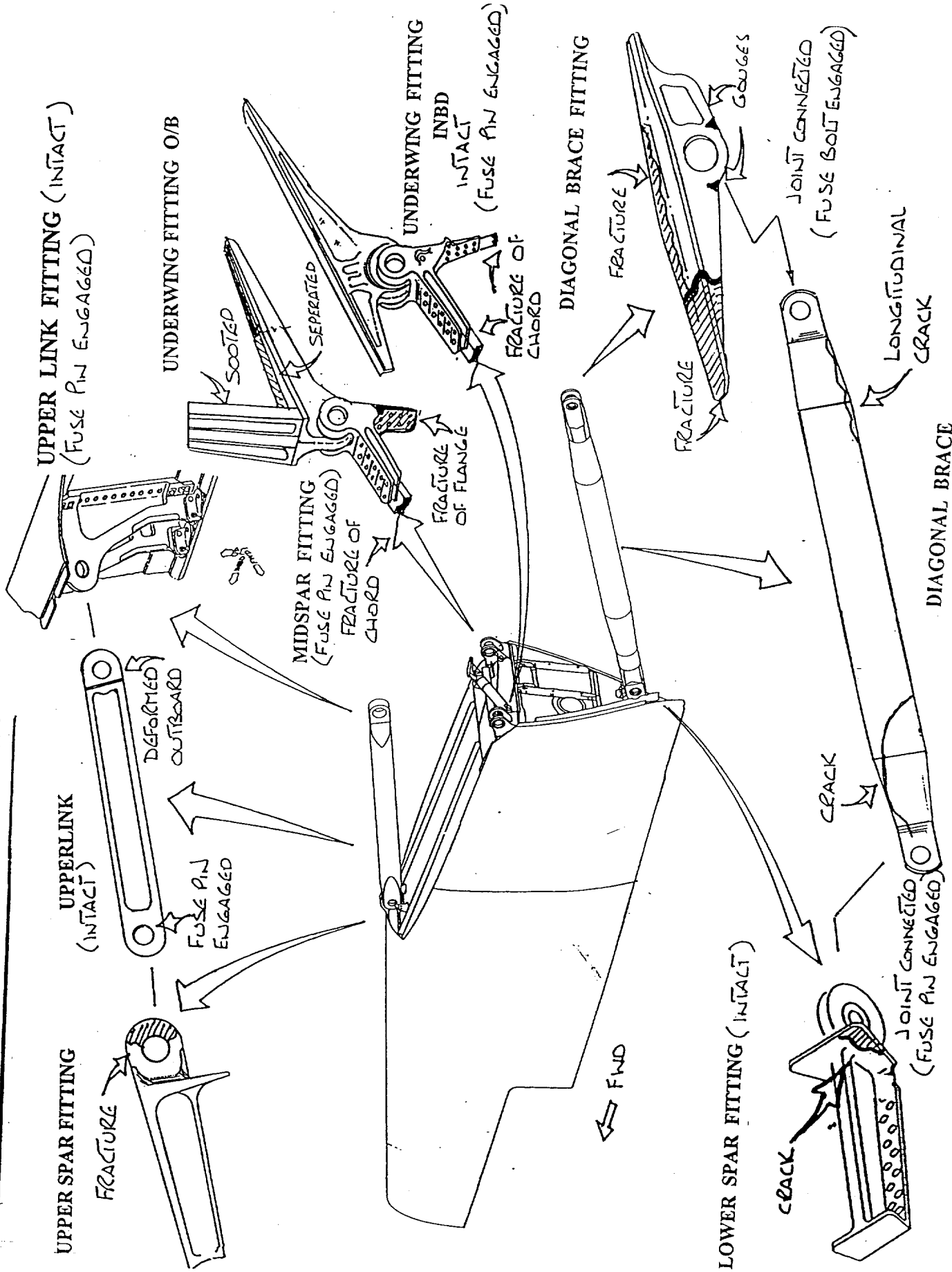

# ENGINE TO STRUT ATTACHMENT

STRUT NO. 3

FORWARD ENGINE MOUNT BULKHEAD (INTACT)

SEPERATED ALONG THIS FRACTURE LINE

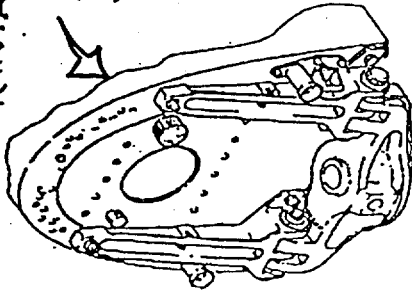

CONE BOLT (INTACT)

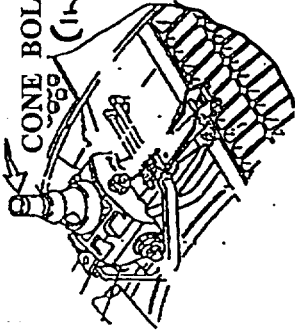

FORWARD

ENGINE MOUNT ATTACHMENT (TO FAN CASE)

ENGINE MOUNT SEPERATED WITH AND CONNECTED TO FAN CASE

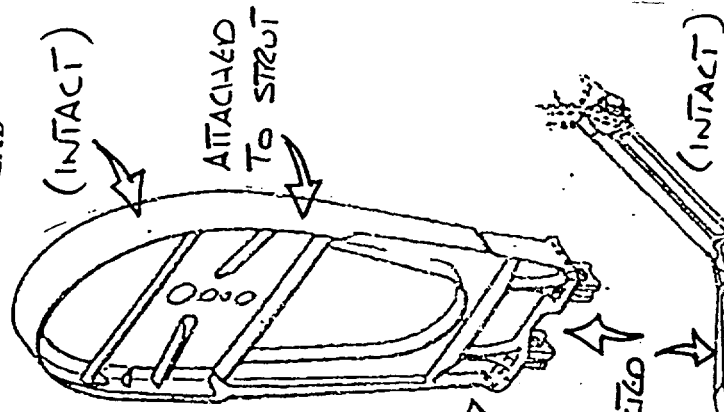

REAR ENGINE MOUNT BULKHEAD

(INTACT)

ATTACHED TO STRUT

CONNECTED

(INTACT)

MID SPAR

WING

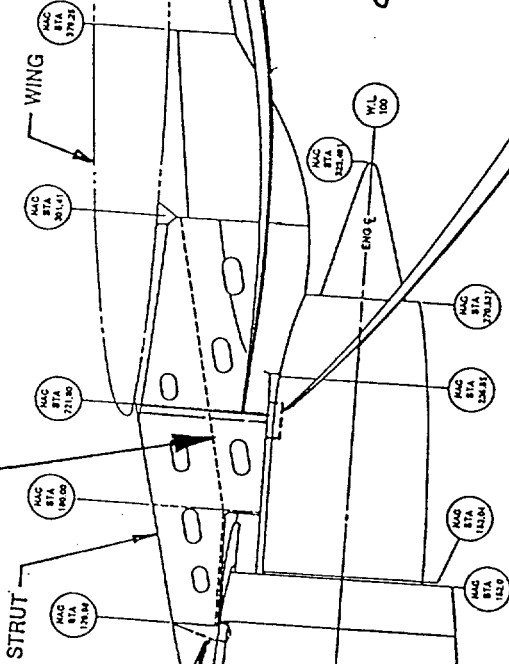

ENGINE

FWD

THRUST LINK ATTACHMENT (INTACT)

CONNECTED

REAR ENGINE MOUNT SEPERATED WITH AND TO TURBINE EXHAUST CASE.

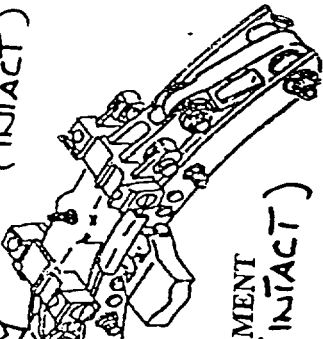

TANGENTIAL LINK ATTACHMENT TO LOWER MOUNT BLOCK (INTACT)

# Strut-to-Wing Connections FUSE BOLTS

## STRUT 3

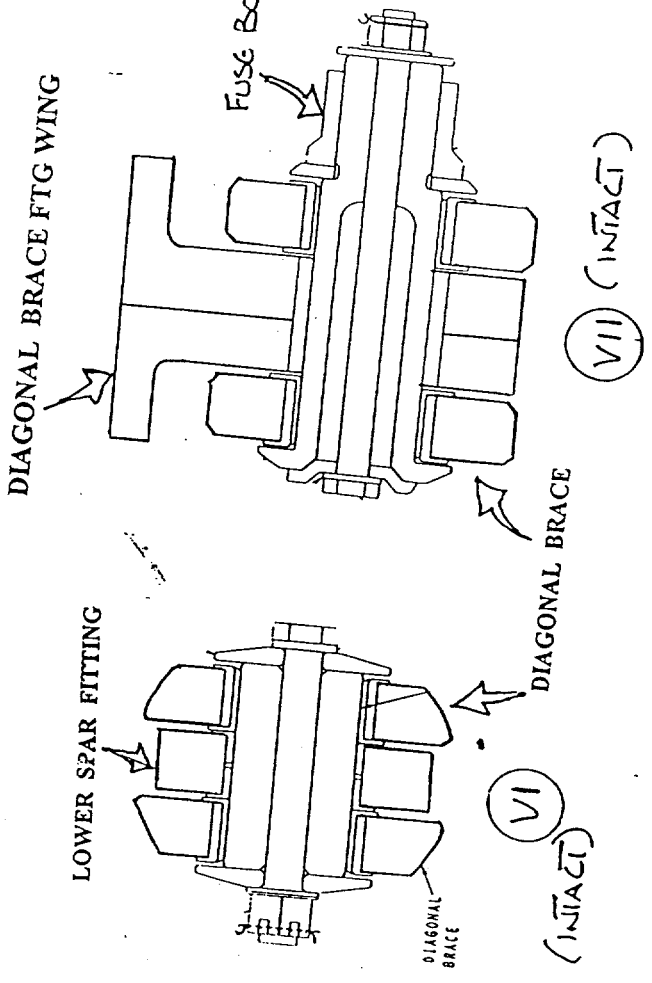
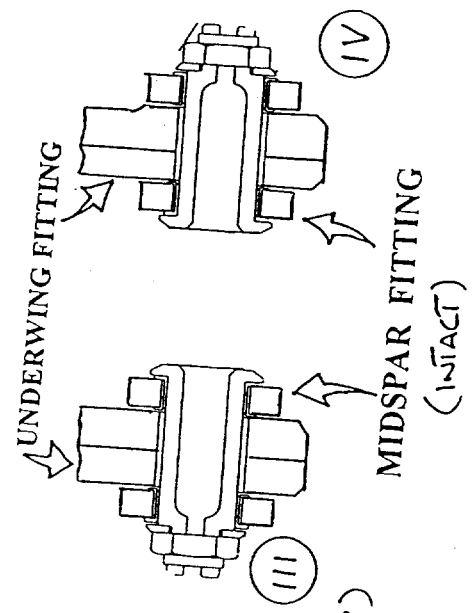
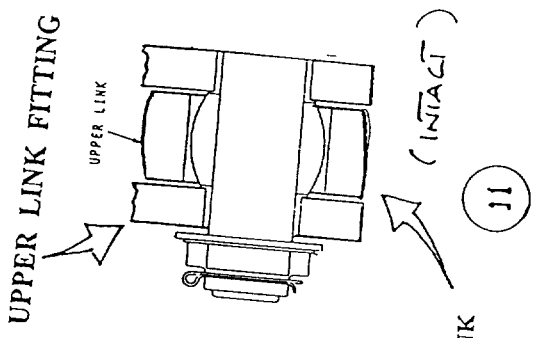
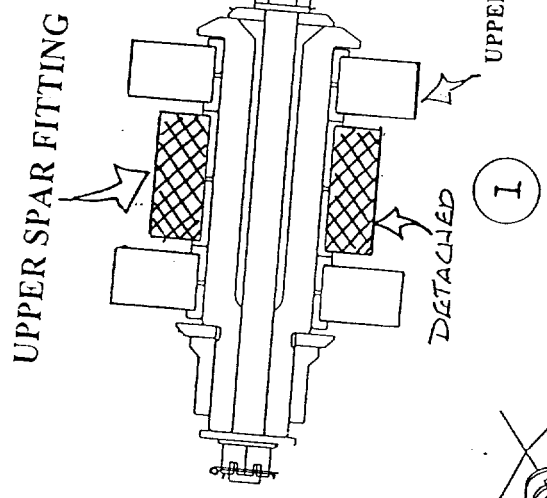
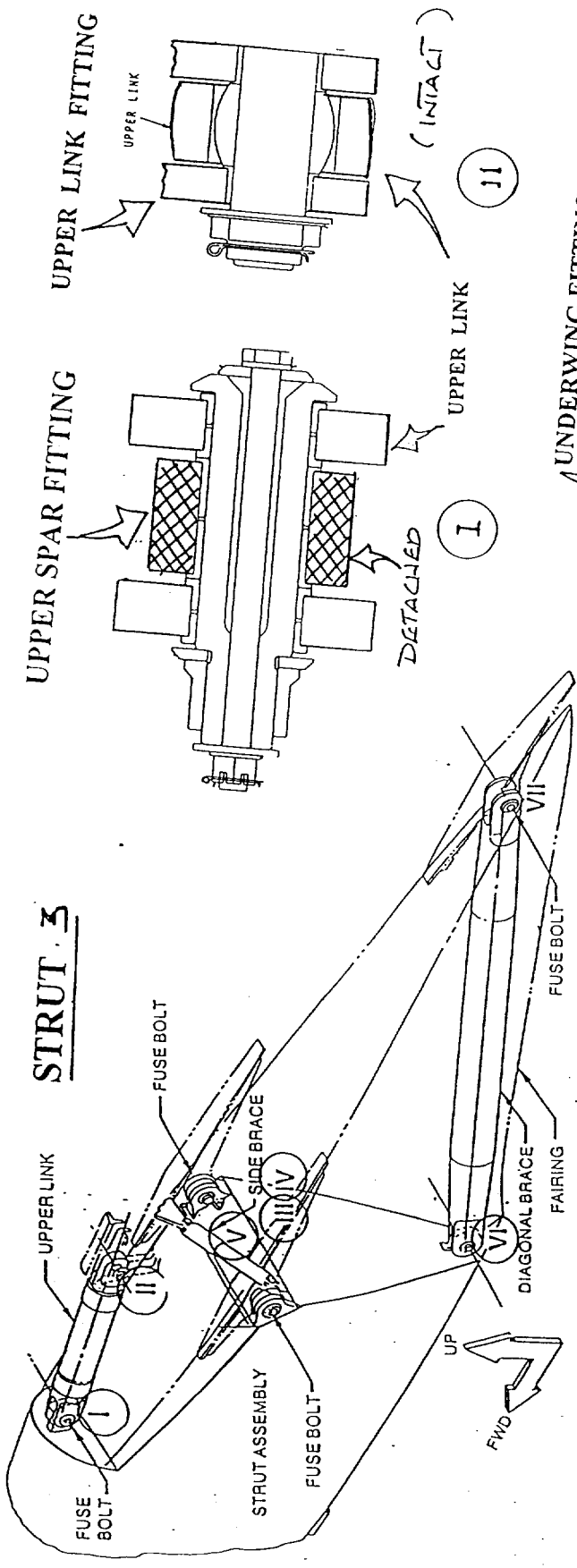

- ATTACHED TO FUSE BOLT
- DETACHED FROM FUSE BOLT

# STRUT - TO - WING CONNECTIONS

## STRUT NO. 4

FORWARD BULKHEAD  
PUSHED AFT

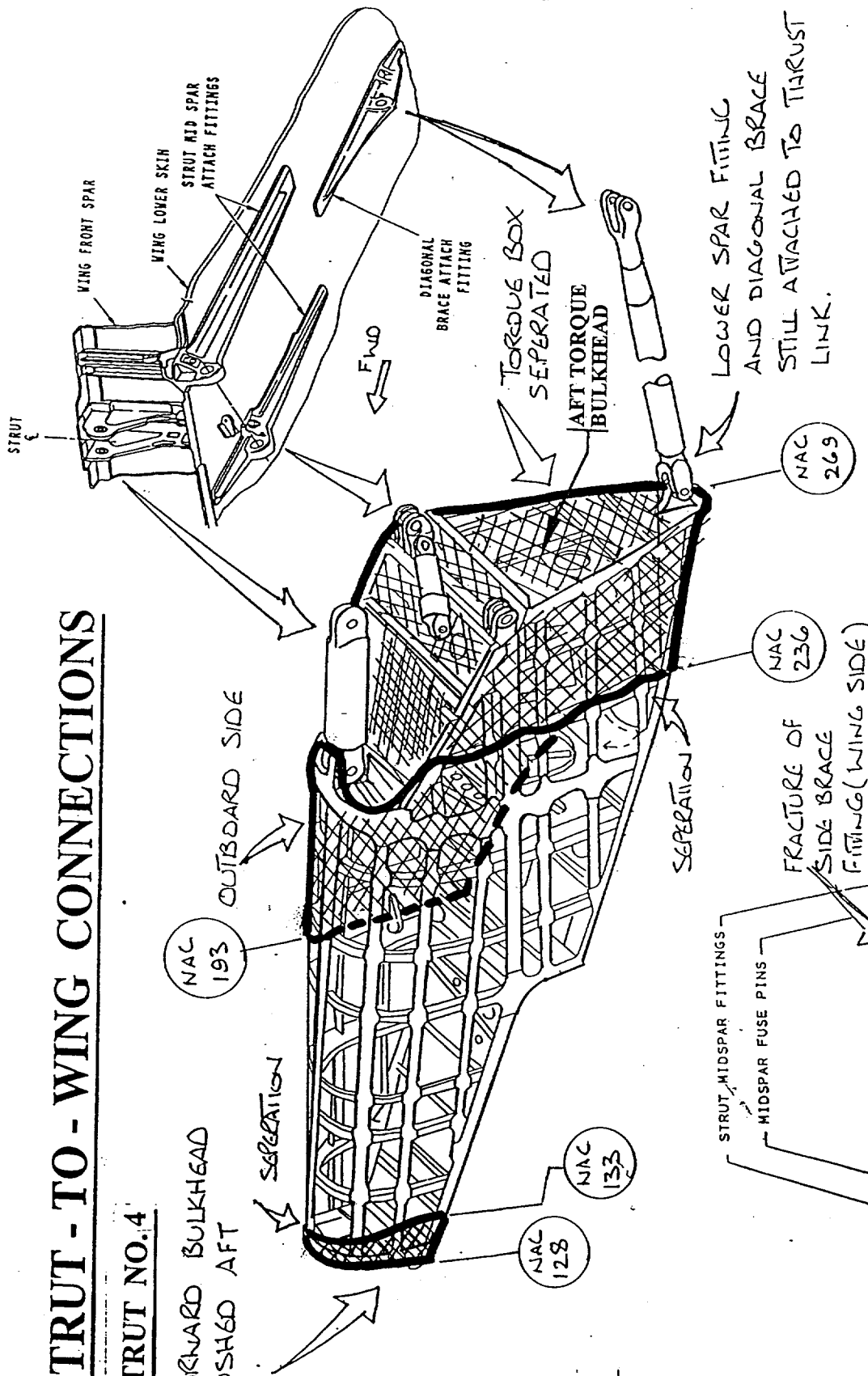

## '3rd Generation' Fuse Pins

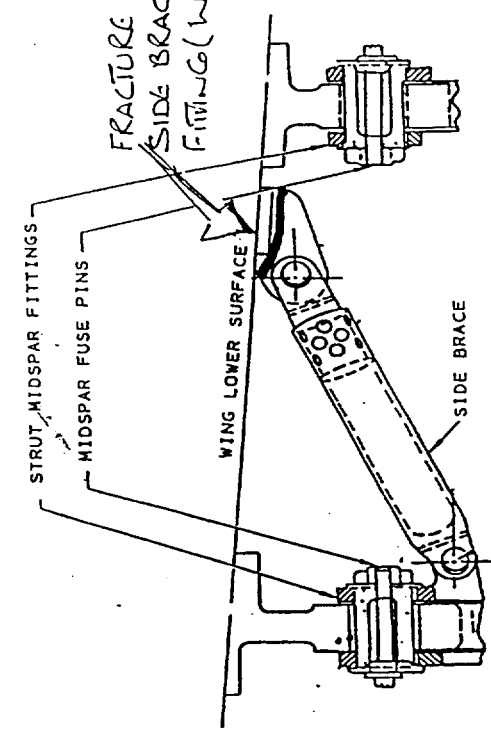

## SIDE BRACE ATTACHMENT

**STRUT-TO-WING CONNECTIONS STRUT NO. 4**

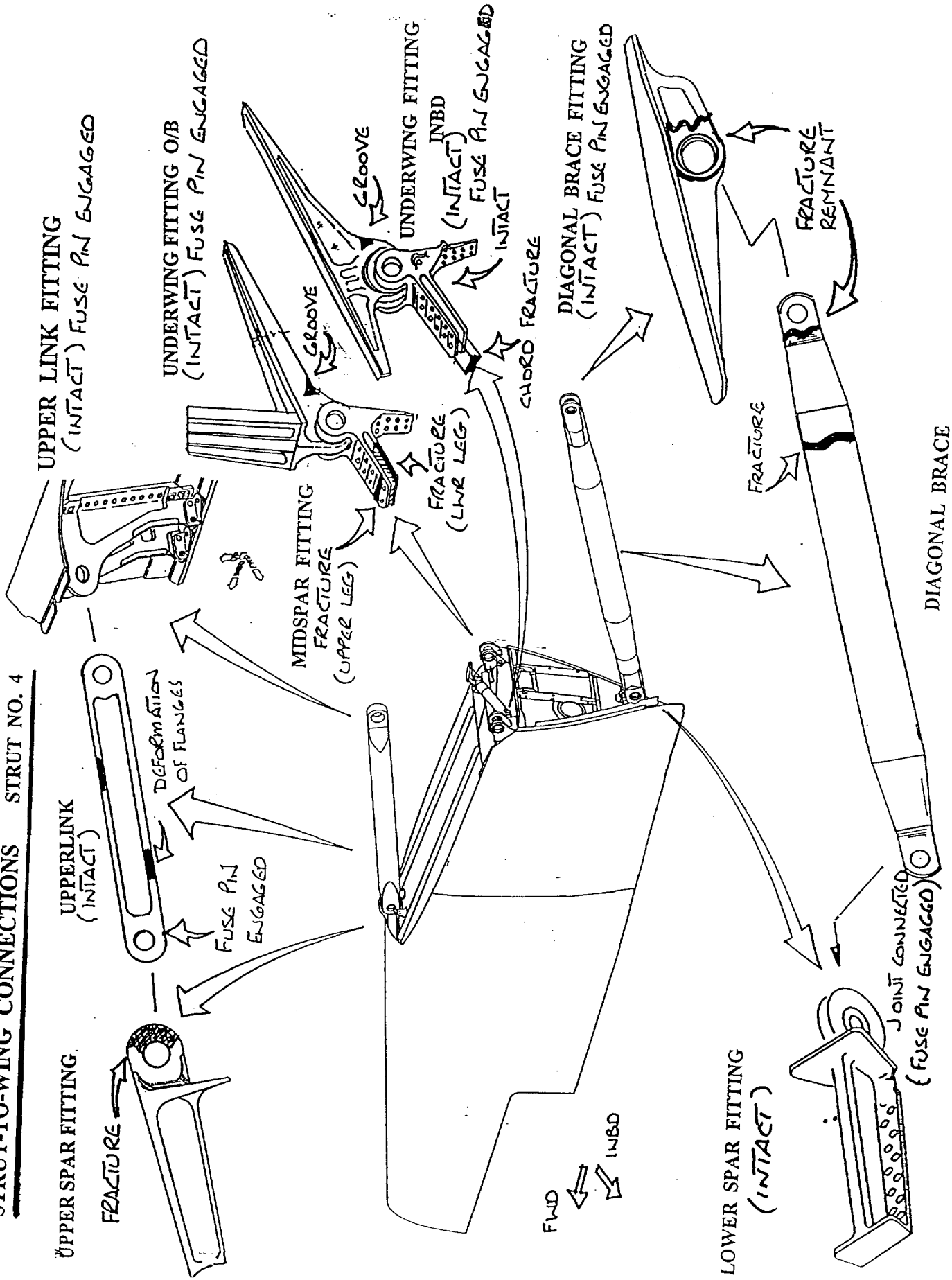

# ENGINE TO STRUT ATTACHMENT

FORWARD ENGINE MOUNT (INTACT)  
BULKHEAD

ATTACHED TO STRUT

BULKHEAD  
PUSHED AFT

STRUT NO. 4

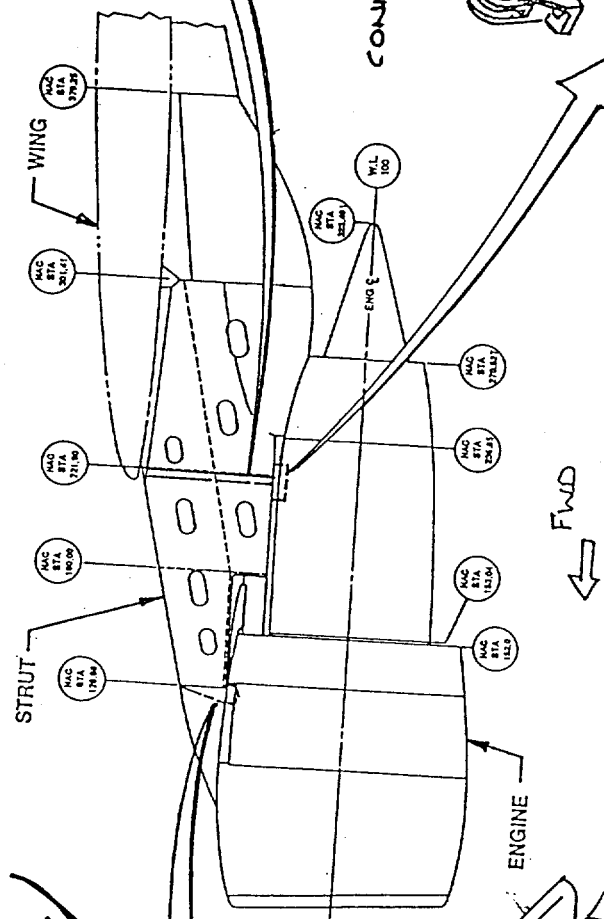

CONE BOLT

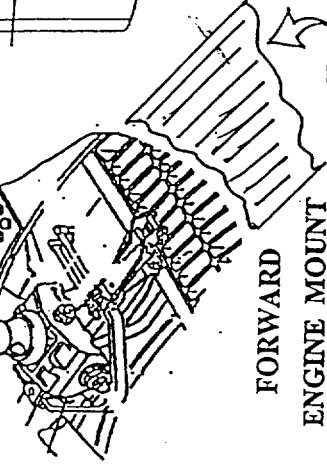

FORWARD  
ENGINE MOUNT  
ATTACHMENT  
(INTACT)  
FAN CASE  
ATTACHED

REAR ENGINE  
MOUNT BULKHEAD

COMPLETELY  
DAMAGED

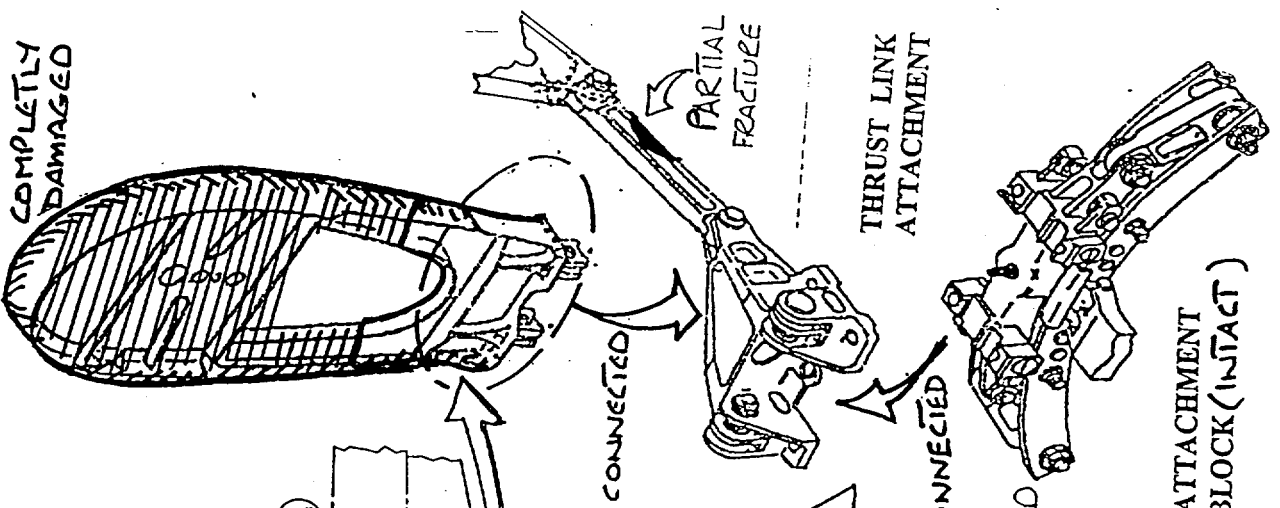

CONNECTED

PARTIAL  
FRACTURE

THRUST LINK  
ATTACHMENT

CONNECTED

REAR ENGINE MOUNT  
SEPERATED WITH AND ATTACHED  
TURBINE EXHAUST CASE

TANGENTIAL LINK ATTACHMENT  
TO LOWER MOUNT BLOCK (INTACT)



# Strut-to-Wing Connections Fuse Bolts

## STRUT 4

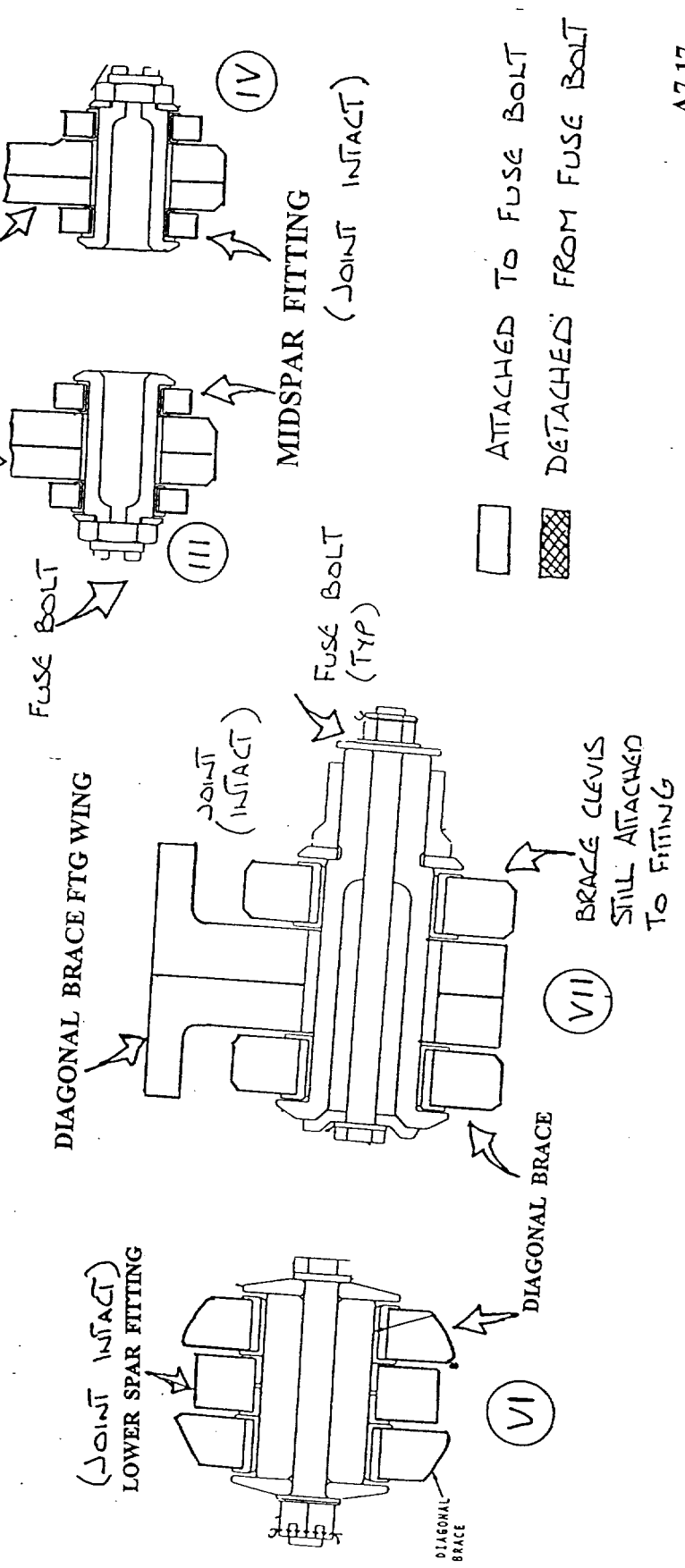
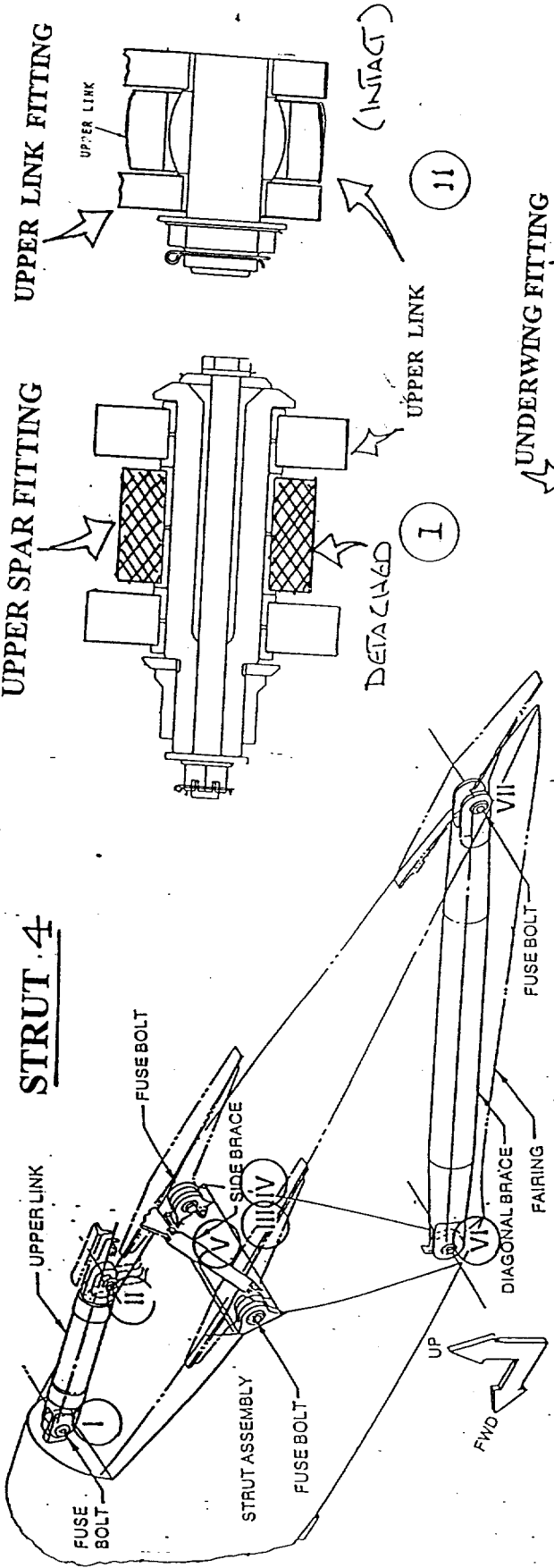

# MIDSPAR FITTING

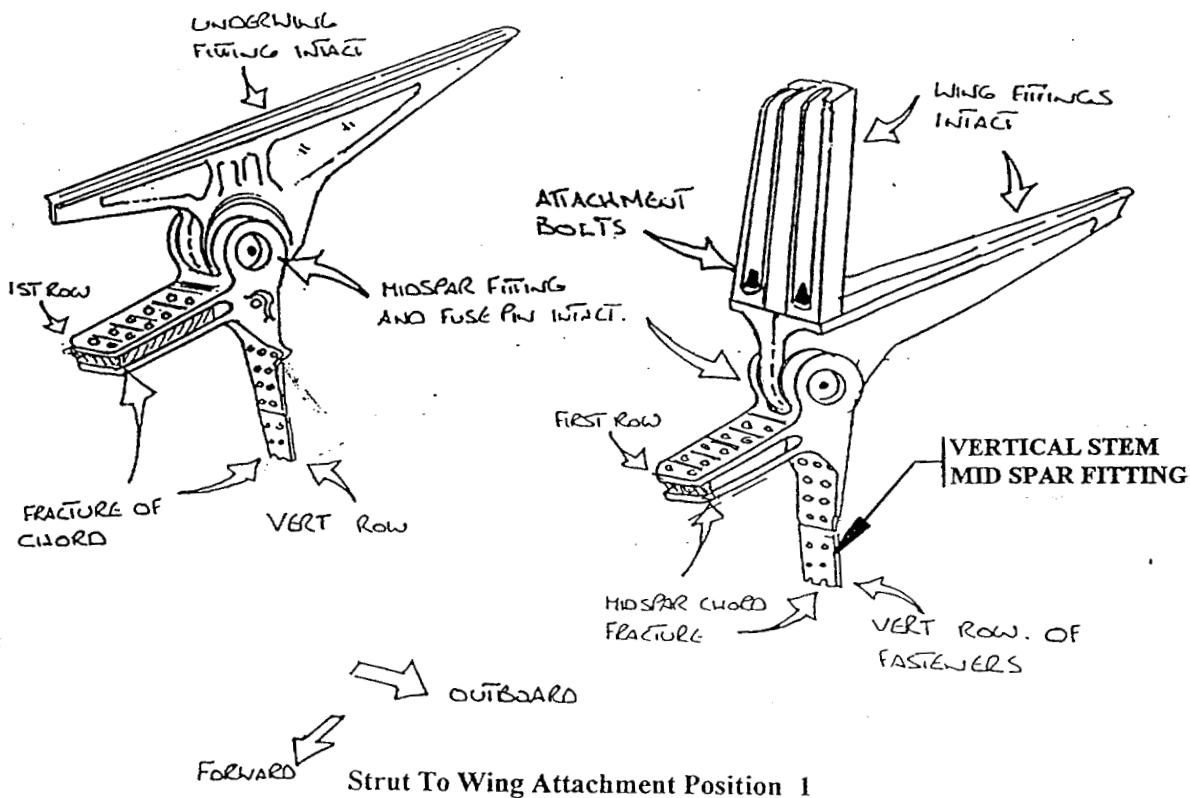

Strut To Wing Attachment Position 1

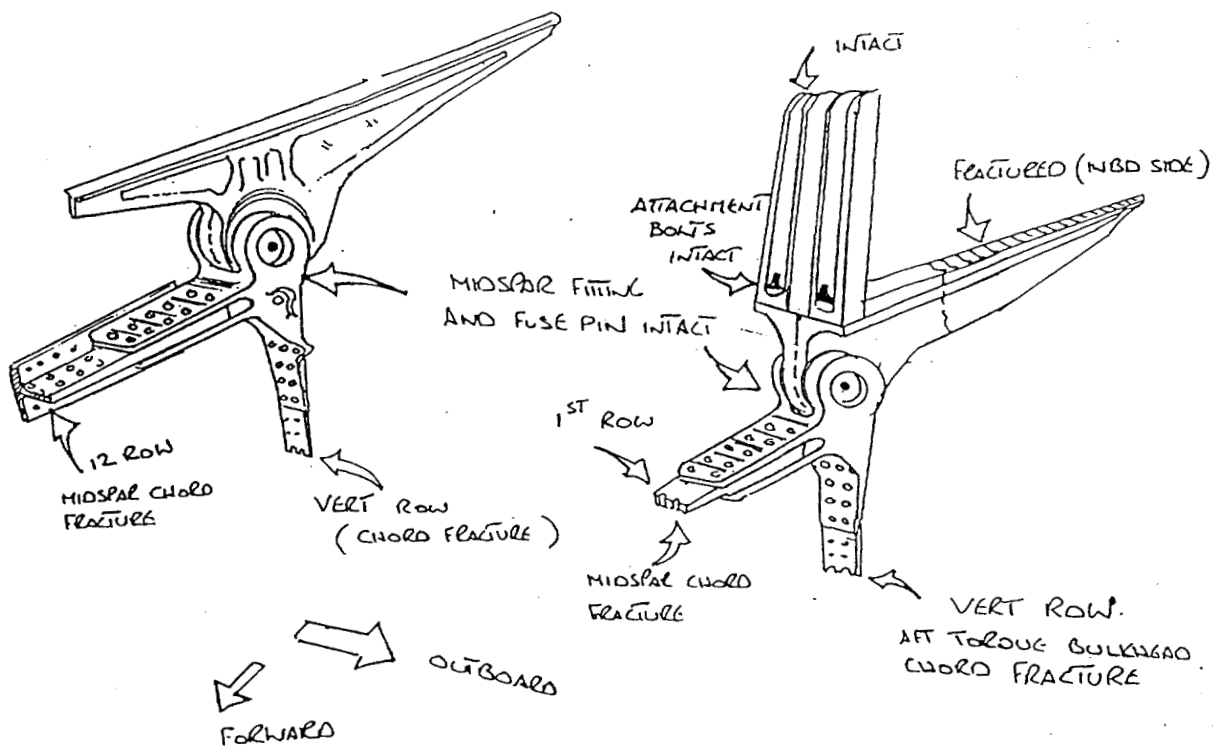

Strut To Wing Attachment Position 2

### MIDSPAR FITTING

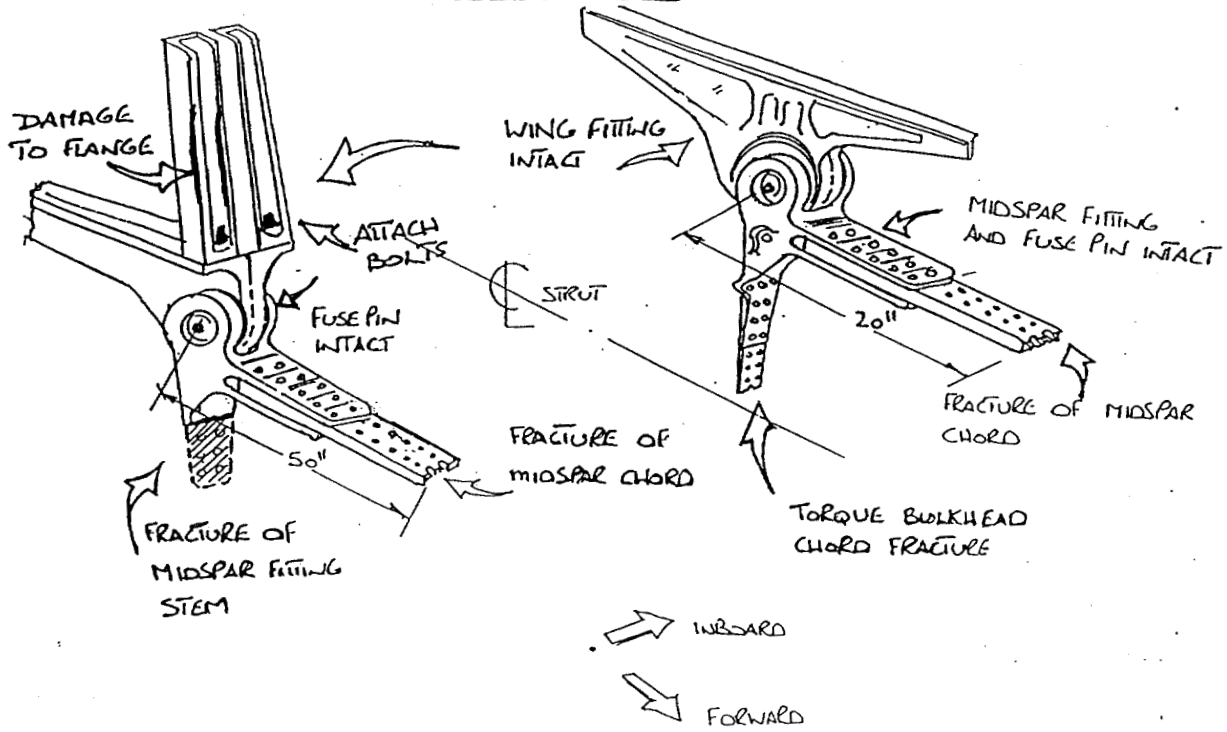

### Strut To Wing Attachment Position 3

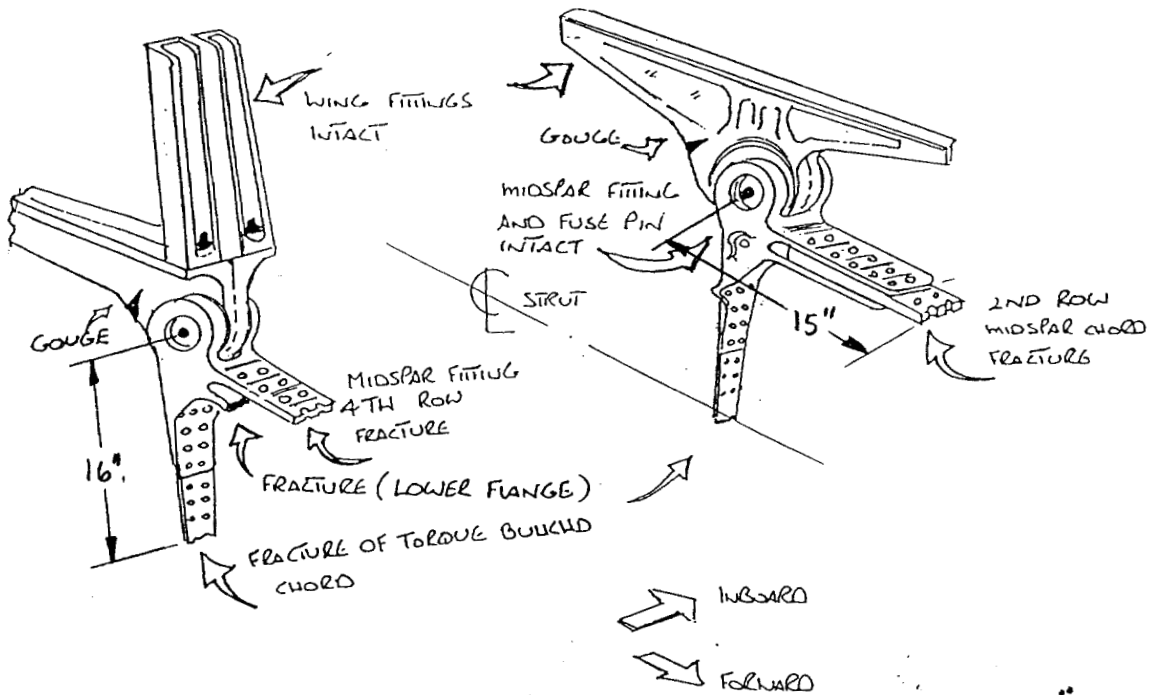

### Strut To Wing Attachment Position 4

# ENGINE TO STRUT ATTACHMENT FORWARD AND REAR ENGINE MOUNT

x - Engine Mount Bulkhead and Fittings Attached to Strut

STRUCTURE	FIGURE	ENGINE POSITION			
		①	②	③	④
FORWARD ENGINE MOUNT	A	X	1	1	X
REAR ENGINE MOUNT	B	X	2	X	2/3

1. Assembly separated from strut and attached to fan case.
2. Attached to turbine exhaust case.
3. Right side tangential link deformed aft.

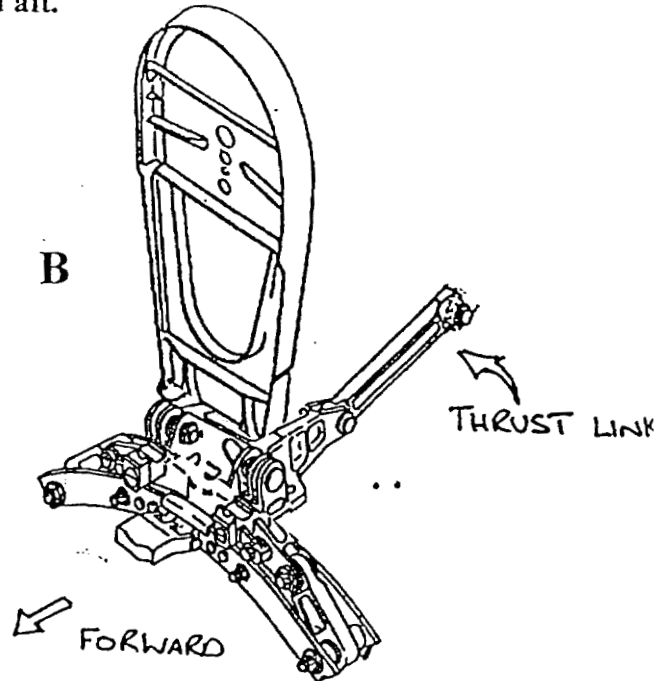
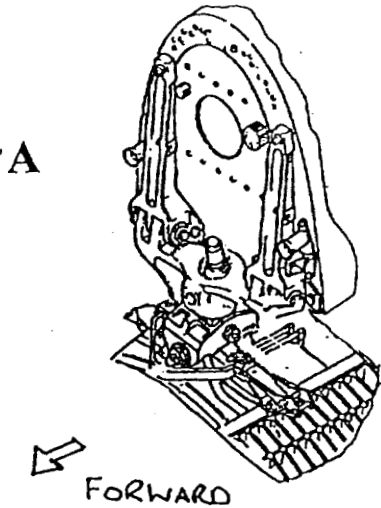

**WING / STRUT ATTACHMENT AND STRUT FITTINGS RECOVERED**

**SUMMARY**

COMPONENT	STRUT 1	STRUT 2	STRUT 3	STRUT 4
MIDSPAR FITTING INBOARD	C876	C884	C186	C186
MIDSPAR FITTING OUTBOARD	C876	Z2830	C186	C186
UNDERWING FITTING INBOARD	C876	C884	C186	C186
UNDERWING FITTING OUTBOARD	C876	Z2830	C186	C186
DIAGONAL BRACE UNDERWING FITTING	Z3082	C006	C209	C186
UPPER LINK FITTING WING	C876	Z3019	C186	C186
FUSE BOLT MIDSPAR INBOARD	C876	C884	C186	C186
FUSE BOLT MIDSPAR OUTBOARD	C876	Z2830	C186	C186
FUSE BOLT DIAGONAL BRACE WING	Z3082	C006	C209	C186
FUSE BOLT DIAGONAL BRACE STRUT	Z3082	X	C209	C186
FUSE BOLT UPPER LINK WING	C876	Z3019	C186	C186
SIDE LINK	C876	X	C186	C186
REAR ENGINE MOUNT BLOCK	C876	X	C186	C186
UPPER LINK	C876	C884	C186	C186
DIAGONAL BRACE	X	X	C012	C186
FORWARD ENGINE MOUNT	X	X	X	X
CONE BOLT (FORWARD MOUNT)	Z3082	X	X	C186
UPPER SPAR FITTING STRUT	X	X	C209	X
LOWER SPAR FITTING STRUT	X	X	X	X
TANGENTIAL LINKS	X	X	X	X
THRUST LINK	X	X	X	X
THRUST YOKE	X	X	X	X
STRUT	X	C012	C012	X
	X	X	X	X
	X	C290	X	C815

NOTE: TARGET NUMBER AS INDICATED

X - NO TARGET NUMBER ISSUED