

DCA-13-MR-002
Derailment/Hazardous Materials Release
Paulsboro, NJ
November 30, 2012

ATTACHMENT 22

Track, Bridge and Signal Circuits

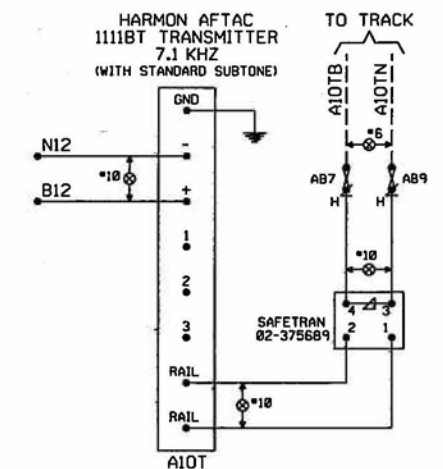
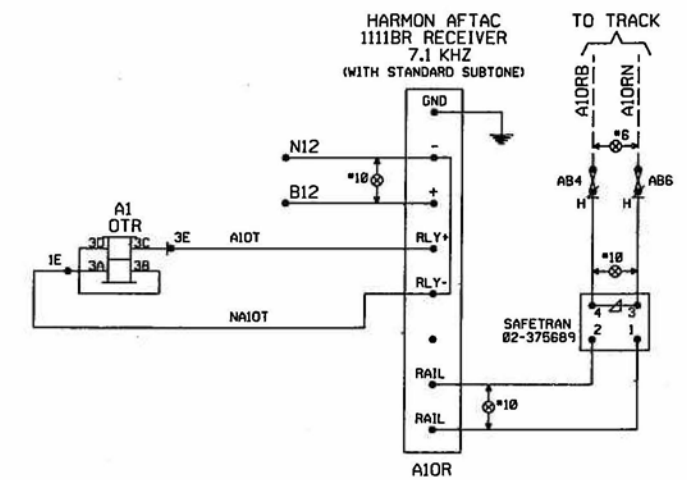
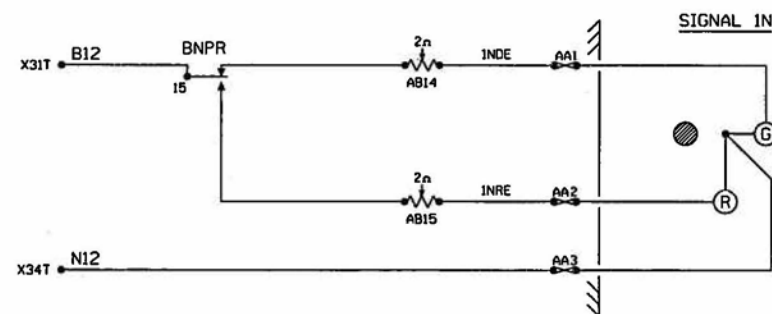
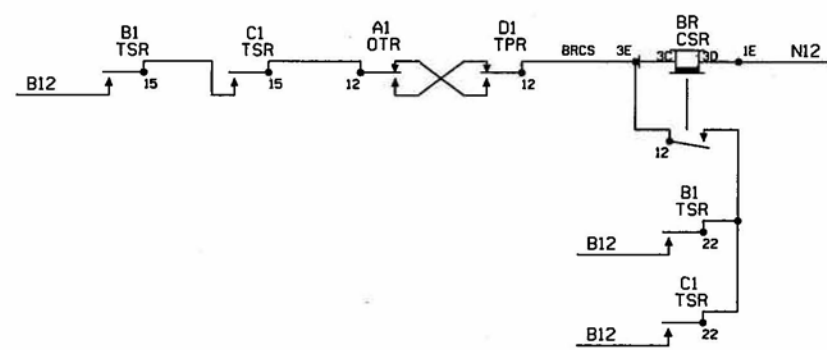
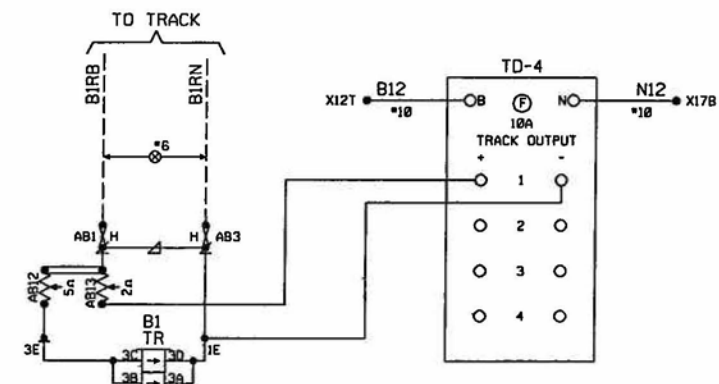
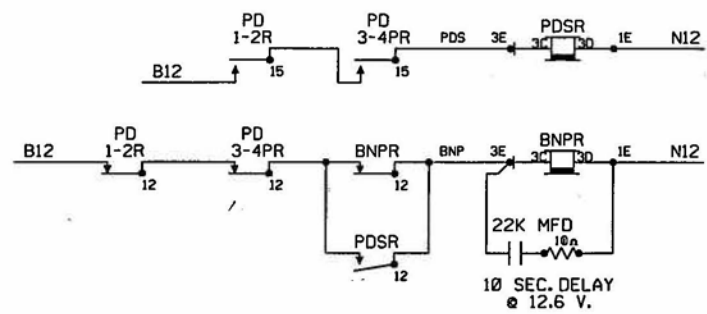
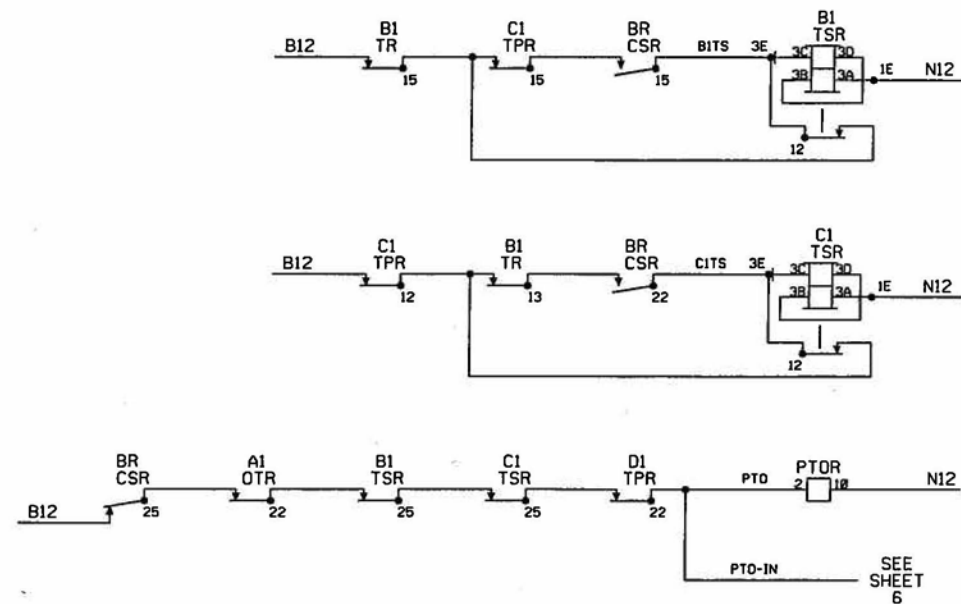

CONRAIL

PAULSBORO MOVEABLE BRIDGE PAULSBORO, NJ

TRACK, BRIDGE AND SIGNAL CIRCUITS
LOC. 1N

ISSUE DATE: JUNE 20, 2003	9912-0137
REV. 1	06-20-03 SHEET 5