

GENERAL NOTES:

(ADJ. AG) = ADJUST AG	(LC) = LIMITED CLEAR
AG = AVERAGE GRADE	(LA) = LIMITED APPROACH
EQ = EQUATED DISTANCE	(MAA) = MEDIUM ADVANCE APPROACH
FS = FOLLOWING STICK	(MC) = MEDIUM CLEAR
ERS = ENGINE RETURN STICK	(MAM) = MEDIUM APPROACH MEDIUM
G = GREEN	(MAS) = MEDIUM APPROACH SLOW
Y = YELLOW	(MA) = MEDIUM APPROACH
R = RED	(SC) = SLOW CLEAR
LW = LUNAR WHITE	(SAS) = SLOW APPROACH SLOW
DWF = DWARF SIGNAL	(SA) = SLOW APPROACH
FG = FLASHING GREEN	(N) = P.O. SWITCH NORMAL
FY = FLASHING YELLOW	(R) = P.O. SWITCH REVERSE

NOTE:

(1) RESTRICTING ASPECTS FOR FOLLOWING MOVES & ENGINE RETURNS AVAILABLE FOR ALL SIGNALLED ROUTES EXCEPT BILOXI BAY DRAWBRIDGE.

(2) ◇ = INDICATED ON LOCAL CONTROL PANEL ONLY.

(3) ☆ = FOR FUTURE TAPELOAD

60 MPH MAXIMUM AUTHORIZED SPEED FREIGHT.

AUTHORITY FOR MOVEMENT CPS-261/ABS-261

TIMETABLE #6 DATED 11-01-12

REVISIONS	
05-15-15 XRL	MS2012007
03-08-16 XRL	MS2012006

SIGNAL ASPECT RULES 1281-1298

CSX TRANSFORMATOR

RAIL TRANSPORT GROUP ENGINEERING COMMUNICATIONS AND SIGNALS

SE OCEAN SPRINGS TO SIGNALS 7271/7272

ASPECT CHART
M.P. 000-723.04 TO M.P. 000-727.36

DESIGNED XRL	DIGITIZED XRL	CHECKED XRL	DATE
			09-11-12

DRAWING	SHEET NO	FILE	SHEET
.....	00072304	K01

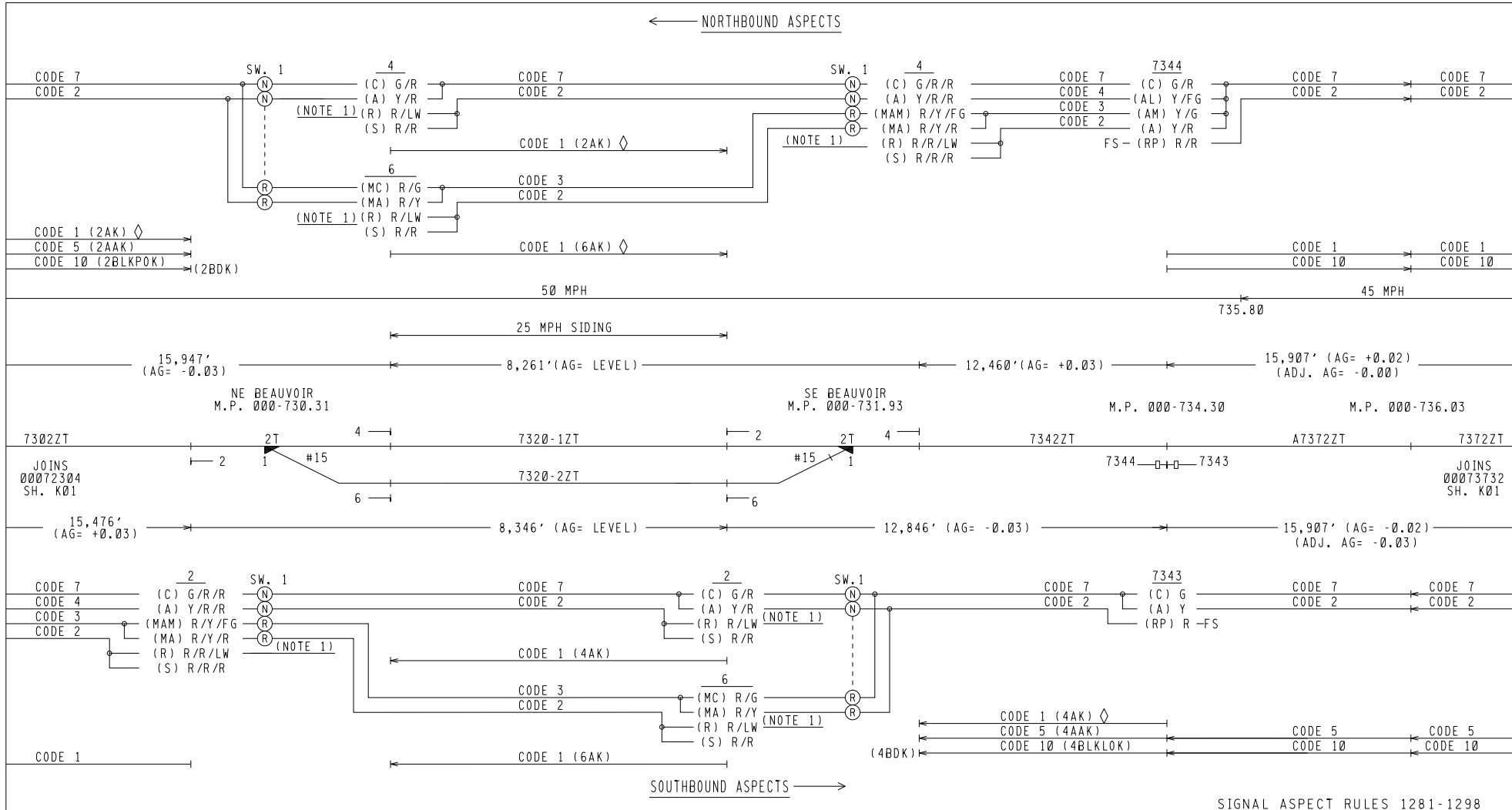

SIGNAL ASPECT RULES 1281-1298

GENERAL NOTES:

AG = AVERAGE GRADE	(C) = CLEAR	(LC) = LIMITED CLEAR
EQ = EQUATED DISTANCE	(A) = APPROACH LIMITED	(LA) = LIMITED APPROACH
FS = FOLLOWING STICK	(AM) = APPROACH MEDIUM	(MAA) = MEDIUM ADVANCE APPROACH
ERS = ENGINE RETURN STICK	(AA) = ADVANCE APPROACH	(MC) = MEDIUM CLEAR
G = GREEN	(AS) = APPROACH SLOW	(MAM) = MEDIUM APPROACH MEDIUM
Y = YELLOW	(A) = APPROACH	(MAS) = MEDIUM APPROACH SLOW
R = RED	(R) = RESTRICTING	(MA) = MEDIUM APPROACH
LW = LUNAR WHITE	(S) = STOP	(SC) = SLOW CLEAR
DWF = DWARF SIGNAL	(RP) = RESTRICTED PROCEED	(SAS) = SLOW APPROACH SLOW
FG = FLASHING GREEN		(SA) = SLOW APPROACH
FY = FLASHING YELLOW		(N) = P.O. SWITCH NORMAL
		(R) = P.O. SWITCH REVERSE

NOTE:

(1) RESTRICTING ASPECTS FOR FOLLOWING MOVES & ENGINE RETURNS AVAILABLE FOR ALL SIGNALLED ROUTES.

(2) ◇ = INDICATED ON LOCAL CONTROL PANEL ONLY.

60 MPH MAXIMUM AUTHORIZED SPEED FREIGHT.
 AUTHORITY FOR MOVEMENT CPS-261/ABS-261
 TIMETABLE #5 DATED 08-23-10

REVISIONS	
03-08-16 XRL	MS2012006, MS2012006B

CSX TRANSFORMATION

RAIL TRANSPORT GROUP ENGINEERING
COMMUNICATIONS AND SIGNALS

NE BEAUVOIR TO CUT SECTION

ASPECT CHART
M.P. 000-730.31 TO M.P. 000-736.02

DESIGNED XRL	DIGITIZED XRL	CHECKED XRL	DATE
			08-27-12
DRAWING	SHEET NO	FILE	SHEET
.....	00073031	K01