

DATE

THE OPERATION OF THE ORGANIZATION REPRESENTED HEREON CANNOT BE CHECKED FINALLY UNTIL ALL CIRCUITS AND DEVICES ARE CONNECTED TO FORM A COMPLETE SYSTEM OR AN EFFECTIVE PORTION THEREOF. SUCH SYSTEM OR PORTION MUST BE GIVEN COMPLETE CIRCUIT AND OPERATIONAL TESTS BEFORE BEING PLACED IN REGULAR OPERATION.

NOTICE OF CONFIDENTIAL INFORMATION: INFORMATION CONTAINED HEREIN IS CONFIDENTIAL AND IS THE PROPERTY OF THE GENERAL RAILWAY SIGNAL COMPANY. WHERE FURNISHED WITH A PROPOSAL THE RECIPIENT SHALL USE IT SOLELY TO EVALUATE THE PROPOSAL. WHERE FURNISHED TO A CUSTOMER IT SHALL BE USED SOLELY FOR PURPOSES OF INSPECTION, INSTALLATION OR MAINTENANCE. WHERE FURNISHED TO A SUPPLIER IT SHALL BE USED SOLELY IN THE PERFORMANCE OF THE CONTRACT. THE INFORMATION SHALL NOT BE USED OR DISCLOSED BY THE RECIPIENT FOR ANY OTHER PURPOSE WHATSOEVER.

DESIGNED _____ JGR
 DRAWN _____ MJB
 CHECKED _____
 APPROVED *M. J. Harris*

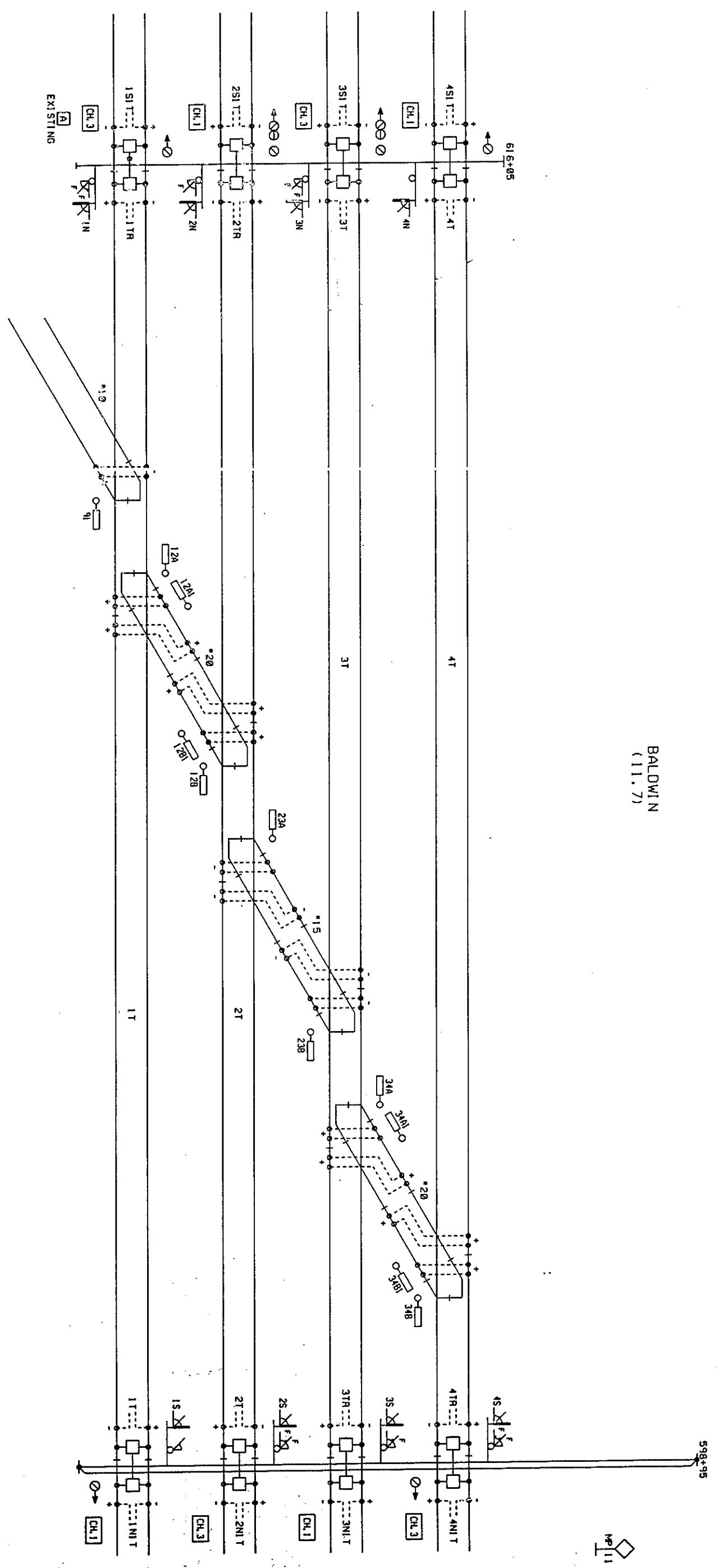

BALDWIN
(11.7)

NOTES: TP1, TP2, TP3, TP5

"BALDWIN" INTERLOCKING
 TRACK PLAN

REV:	ISSUE DATE:	DATE:	SHEET 005
		10-10-98	

DATE

141-4 SIG

S&P (R) TO BLK OCCUPIED
A (A) TO 4S (HOOK) (TO CCP THEN R)
AM (AM) TO 4S (HOOK) MA OR MC
AL (AM) TO 4S (HOOK) LC
C (C) TO 4S (HOOK) A OR C

127-4 SIG

S&P (R) TO BLK OCCUPIED
A (A) TO 141-4 (TO CCP THEN R)
C (C) TO 141-4 A, AM, AL OR C

4S SIG (BALDWIN)

SS
S&P (R) TO BLK OCCUPIED
A (A) TO 127-4 (TO CCP THEN R)
C (C) TO 127-4 A OR C
MA (A) TO 127-1, -2, -3 (TO CCP THEN R)
LC (AM) TO 127-3 A OR C
MC (AM) TO 127-1 OR -2 A OR C

95-4 SIG

S&P (R) TO BLK OCCUPIED
A (A) TO 4S (BALDWIN) (TO CCP THEN R)
A (A) TO 4S (BALDWIN) SA
AL (AM) TO 4S (BALDWIN) LC
AM (AM) TO 4S (BALDWIN) MC OR MA
C (C) TO 4S (BALDWIN) A (TO CCP THEN AM)
C (C) TO 4S (BALDWIN) C

75-4 SIG

S&P (R) TO BLK OCCUPIED
A (A) TO 95-4 (TO CCP THEN R)
C (C) TO 95-4 A, AM, AL OR C

141-3 SIG

S&P (R) TO BLK OCCUPIED
A (A) TO 3S (HOOK) (TO CCP THEN R)
AM (AM) TO 3S (HOOK) MA OR MC
AL (AM) TO 3S (HOOK) LC
C (C) TO 3S (HOOK) A OR C

127-3 SIG

S&P (R) TO BLK OCCUPIED
A (A) TO 141-3 (TO CCP THEN R)
C (C) TO 141-3 A, AM, AL OR C

3S SIG (BALDWIN)

SS
S&P (R) TO BLK OCCUPIED
A (A) TO 127-3 (TO CCP THEN R)
C (C) TO 127-3 A (TO CCP THEN AM)
C (C) TO 127-3 C
MA (A) TO 127-1, -2 (TO CCP THEN R)
MC (AM) TO 127-1 OR -2 A OR C

95-3 SIG

S&P (R) TO BLK OCCUPIED
A (A) TO 3S (BALDWIN) (TO CCP THEN R)
A (A) TO 3S (BALDWIN) SA
AM (AM) TO 3S (BALDWIN) MC OR MA
C (C) TO 3S (BALDWIN) A (TO CCP THEN AM)
C (C) TO 3S (BALDWIN) C

75-3 SIG

S&P (R) TO BLK OCCUPIED
A (A) TO 95-3 (TO CCP THEN R)
C (C) TO 95-3 A, AM OR C

141-2 SIG

S&P (R) TO BLK OCCUPIED
A (A) TO 2S (HOOK) (TO CCP THEN R)
AM (AM) TO 2S (HOOK) MA OR MC
AL (AM) TO 2S (HOOK) LC
C (C) TO 2S (HOOK) A OR C

127-2 SIG

S&P (R) TO BLK OCCUPIED
A (A) TO 141-2 (TO CCP THEN R)
C (C) TO 141-2 A, AM, AL OR C

2S SIG (BALDWIN)

SS
S&P (R) TO BLK OCCUPIED
A (A) TO 127-2 (TO CCP THEN R)
C (C) TO 127-2 A (TO CCP THEN AM)
C (C) TO 127-2 C
MA (A) TO 127-1 (TO CCP THEN R)
LC (AM) TO 127-1 A OR C

95-2 SIG

S&P (R) TO BLK OCCUPIED
A (A) TO 2S (BALDWIN) (TO CCP THEN R)
A (A) TO 2S (BALDWIN) SA
AL (AM) TO 2S (BALDWIN) MA OR LC
C (C) TO 2S (BALDWIN) A (TO CCP THEN AM)
C (C) TO 2S (BALDWIN) C

75-2 SIG

S&P (R) TO BLK OCCUPIED
A (A) TO 95-2 (TO CCP THEN R)
C (C) TO 95-2 A, AL OR C

141-1 SIG

S&P (R) TO BLK OCCUPIED
A (A) TO 1S (HOOK) (TO CCP THEN R)
AM (AM) TO 1S (HOOK) MA OR MC
AL (AM) TO 1S (HOOK) LC
C (C) TO 1S (HOOK) A OR C

127-1 SIG

S&P (R) TO BLK OCCUPIED
A (A) TO 141-1 (TO CCP THEN R)
C (C) TO 141-1 A, AM, AL OR C

1S SIG (BALDWIN)

SS
S&P (R) TO BLK OCCUPIED
A (A) TO 127-1 (TO CCP THEN R)
C (C) TO 127-1 A OR C

95-1 SIG

S&P (R) TO BLK OCCUPIED
A (A) TO 1S (BALDWIN) (TO CCP THEN R)
A (A) TO 1S (BALDWIN) SA
C (C) TO 1S (BALDWIN) A (TO CCP THEN AM)
C (C) TO 1S (BALDWIN) C

75-1 SIG

S&P (R) TO BLK OCCUPIED
A (A) TO 95-1 (TO CCP THEN R)
C (C) TO 95-1 A OR C

THE OPERATION OF THE ORGANIZATION REPRESENTED HEREON CANNOT BE CHECKED FINALLY UNTIL ALL CIRCUITS AND DEVICES ARE CONNECTED TO FORM A COMPLETE SYSTEM OR AN EFFECTIVE PORTION THEREOF. SUCH SYSTEM OR PORTION MUST BE GIVEN COMPLETE CIRCUIT AND OPERATIONAL TESTS BEFORE BEING PLACED IN REGULAR OPERATION.

NOTICE OF CONFIDENTIAL INFORMATION: INFORMATION CONTAINED HEREIN IS CONFIDENTIAL AND IS THE PROPERTY OF THE GENERAL RAILWAY SIGNAL COMPANY. WHERE FURNISHED WITH A PROPOSAL THE RECIPIENT SHALL USE IT SOLELY TO EVALUATE THE PROPOSAL. WHERE FURNISHED TO A CUSTOMER IT SHALL BE USED SOLELY FOR PURPOSES OF INSPECTION, INSTALLATION OR MAINTENANCE. WHERE FURNISHED TO A SUPPLIER IT SHALL BE USED SOLELY IN THE PERFORMANCE OF THE CONTRACT. THE INFORMATION SHALL NOT BE USED OR DISCLOSED BY THE RECIPIENT FOR ANY OTHER PURPOSE WHATSOEVER.

DESIGNED --- JGR
DRAWN --- MFB
CHECKED ---

APPROVED

Moffatt

"BALDWIN" INTERLOCKING

SIGNAL ASPECTS
SOUTHWARD

ISSUE DATE:

REV:

DATE: 10-10-98

SHEET 007

DATE _____

THE OPERATION OF THE ORGANIZATION REPRESENTED HEREIN CANNOT BE CHECKED FINALLY UNTIL ALL CIRCUITS AND DEVICES ARE CONNECTED TO FORM A COMPLETE SYSTEM OR AN EFFECTIVE PORTION THEREOF. SUCH SYSTEMS OR PORTIONS MUST BE GIVEN COMPLETE CIRCUIT AND OPERATIONAL TESTS BEFORE BEING PLACED IN CELEBRATION OPERATION.

NOTICE OF CONFIDENTIAL INFORMATION CONTAINED HEREIN IS CONFIDENTIAL AND IS THE PROPERTY OF THE GENERAL RAILWAY SIGNAL COMPANY. WHERE FURNISHED WITH A PROPOSAL THE RECIPIENT SHALL USE IT SOLELY TO EVALUATE THE PROPOSAL. WHERE FURNISHED TO A CUSTOMER IT SHALL BE USED SOLELY FOR PURPOSES OF INSPECTION, INSTALLATION OR MAINTENANCE. WHERE FURNISHED TO A SUPPLIER IT SHALL BE USED SOLELY IN THE PERFORMANCE OF THE CONTRACT. THE INFORMATION SHALL NOT BE USED OR DISCLOSED BY THE RECIPIENT FOR ANY OTHER PURPOSE WHATSOEVER.

DESIGNED JGR
DRAWN RLL
CHECKED _____

APPROVED
Moffatt

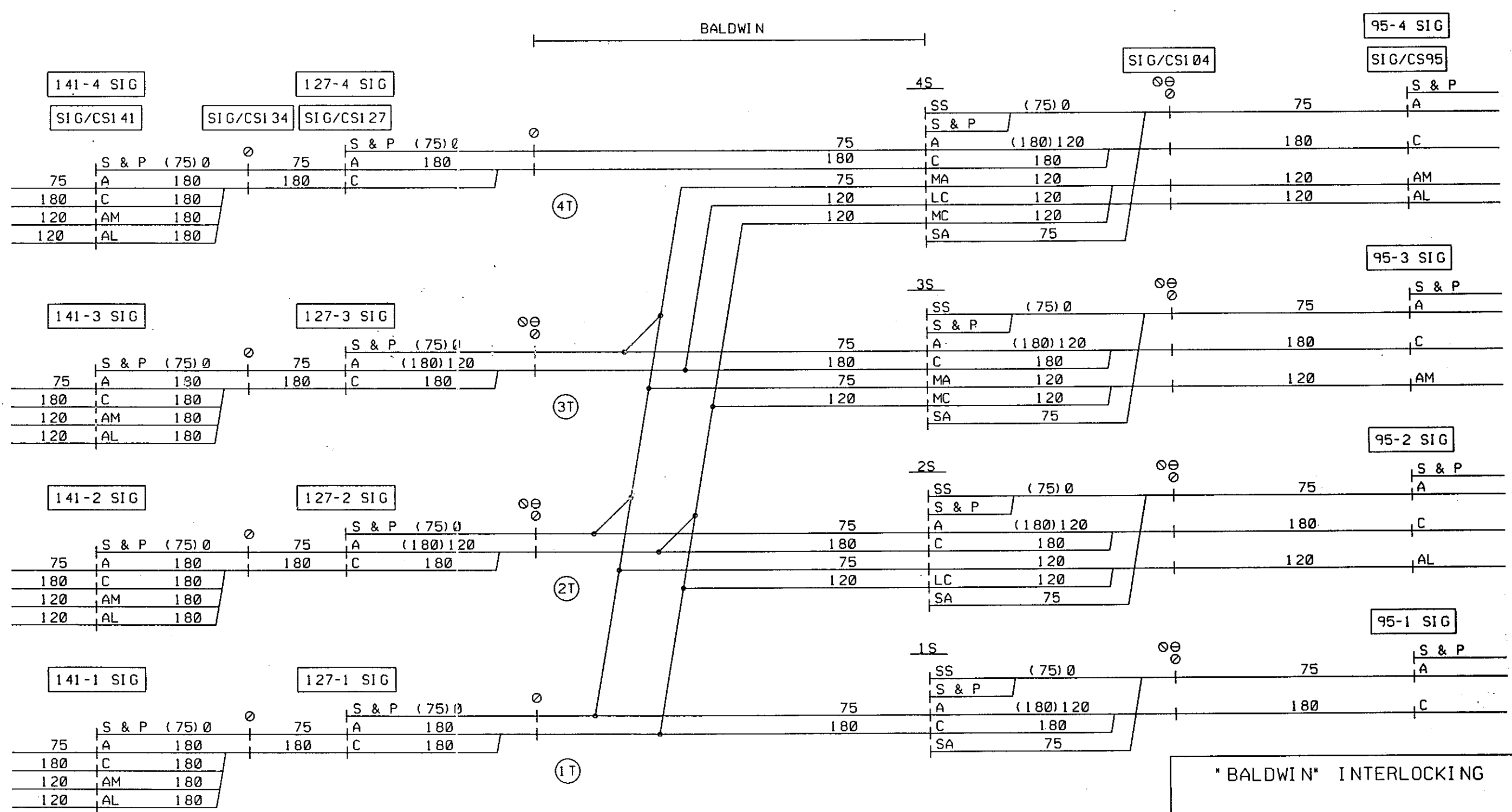

NOTES: NOT EXCEEDING
LIMITED SPEED = 45 MPH - PSGR, 40 MPH - FRT
MEDIUM SPEED = 30 MPH
SLOW SPEED = 15 MPH

"BALDWIN" INTERLOCKING

ROUTE & ASPECT CHART
SOUTHBOUND

ISSUE DATE:	
REV:	DATE: 10-10-98
SHEET 009	