

**REVISION TRANSMITTAL****REASON**

This sheet transmits Revision 1 to CAB-32-01, which:

- A. Changes the 2682005-13 Inboard Return Spring Support to 2682005-15 Inboard Return Spring Support.
- B. Makes miscellaneous changes as required.

**NOTE:** This revision replaces the Original Issue of CAB-32-01 in its entirety.

**NOTE:** The Original Issue of CAB-32-01 was never distributed by Cessna Aircraft Company.

**REVISION COMPLIANCE**

Compliance with CAB-32-01 Revision 1 is required if in compliance with the Original Issue.

**LOG OF REVISIONS**

Original Issue	September 20, 2013
Revision 1	March 14, 2014



**TITLE**

LANDING GEAR - BRAKE SYSTEM MODIFICATION AND CLEANSING PROCEDURE

**EFFECTIVITY****Group A Airplanes:**

<b>MODEL</b>	<b>SERIAL NUMBERS</b>
208	20800001 thru 20800423, 20800500 thru 20800532
208B	208B0001 thru 208B1081, 208B1083 thru 208B1317, 208B2000 thru 208B2163, 208B2165 thru 208B2259, 208B2261, 208B2263, 208B2264, 208B2266 thru 208B2286, 208B2288 thru 208B2297, 208B2300, 208B2302, 208B2305, 208B2306, 208B2310 thru 208B2325

Group A airplanes must do a modification of the brake system and a one-time cleansing of the brake system.

**Group B Airplanes:**

<b>MODEL</b>	<b>SERIAL NUMBERS</b>
208	20800533 thru 20800546
208B	208B1082, 208B2164, 208B2260, 208B2262, 208B2265, 208B2287, 208B2298, 208B2299, 208B2301, 208B2303, 208B2304, 208B2307 thru 208B2309, 208B2326 thru 208B2382, 208B2384 thru 208B2403, 208B2405 thru 208B2413, 208B2415 thru 208B4999

Group B airplanes must do a modification of the brake system only. For Group B airplanes, a cleansing of the brake system is not required.

**REASON**

A modification to add brake return spring assemblies will improve operation of the brake system. For some airplanes, a cleansing of the brake system is also necessary.

**DESCRIPTION**

This service bulletin provides parts and procedures to do a modification of the brake system to add brake return spring assemblies. For some airplanes, a cleansing of the brake system must also be accomplished.

**COMPLIANCE**

Mandatory: Shall be accomplished within 400 hours of operation or 18 months, whichever occurs first.

**APPROVAL**

Cessna received FAA approval for the technical data in this publication that changes the airplane type design.

Cessna received EASA approval for the technical data in this publication that changes the airplane type design.

**WEIGHT AND BALANCE INFORMATION**

Negligible

**CONSUMABLE MATERIAL**

The following materials, or equivalent, are necessary.

NAME	NUMBER	MANUFACTURER	USE
Hydraulic Fluid	MIL-PRF-5606	Commercially available	To replenish the brake system
Isopropyl Alcohol		Commercially available	Cleaning
Locquic Primer T	Catalog Number 747-56	Commercially available	To install the upper clevis on the brake master cylinder rod
Loctite 222 (or 242) Anaerobic Adhesive	U074040 (Loctite 222) or U074062 (Loctite 242)	Cessna Aircraft Company Cessna Service Parts and Programs 5800 East Pawnee PO Box 1521 Wichita, KS 67218	To install the upper clevis on the brake master cylinder rod

The equipment below, or equivalent, may also be necessary:

NAME	MANUFACTURER	USE
Syringe	Commercially available	To remove hydraulic fluid from the brake reservoir
Rudder Travel Protractor	Commercially available	To do a check for correct rudder travel
AN815-3D Union Fitting (or equivalent 3/16 union flared fitting)	Commercially available	To use in flush procedure

**ACCOMPLISHMENT INSTRUCTIONS**

**NOTE:** Group A airplanes must accomplish Step 1 of this service bulletin. Step 1 accomplishes the cleansing and the modification of the brake system. Group A airplanes do not accomplish Step 2 of this service bulletin.

Group B airplanes must accomplish Step 2 of this service bulletin. Step 2 accomplishes the modification of the brake system. Group B airplanes do not accomplish Step 1 of this service bulletin.

1. Group A airplanes do as follows:
  - A. Prepare the airplane for maintenance.
    - (1) Electrically ground the airplane.
    - (2) Make sure that all switches are in the OFF/NORM position.
    - (3) Disconnect electrical power from the airplane.
      - (a) Disconnect external electrical power.

- (b) Disconnect the airplane battery.
- B. Remove the parts that follow from the airplane:
1. Remove the pilot's seat. (Refer to the Model 208 Maintenance Manual, Chapter 25, Flight Compartment - Maintenance Practices.)
  2. Remove the control column cover. (Refer to the Model 208 Maintenance Manual, Chapter 25, Floor Covering/Control Column Cover - Maintenance Practices.)
  3. As necessary, remove panel 226A from the pedestal. (Refer to the Model 208 Maintenance Manual, Chapter 6, Access Plates and Panels Identification - Description and Operation.)
  4. (Refer to Figure 1, Detail A and Detail D, Sheets 5, 6, and 7.) Remove the pilot's foot rest assembly from the airplane. Keep the foot rest assembly and the attachment hardware.
  5. (Refer to Figure 1, Detail A and Detail B.) Remove the 2613259-4 Cover. Keep the cover and the attachment hardware.
  6. (Refer to Figure 1, Detail A and Detail C.) Remove the 2613259-1 Cover. Keep the cover and the attachment hardware.
- C. Get access to the hydraulic fluid reservoir.
- NOTE:** The hydraulic fluid reservoir is installed on the lower left corner of the firewall in the engine compartment.
- D. Drain, remove, and clean the brake hydraulic fluid reservoir and cap as follows:
- (1) Drain or evacuate hydraulic fluid from the reservoir and discard the fluid.
  - (2) Disconnect the AN833-3D Line Nut Fitting from the line, and then remove the reservoir mounting strap. Remove the reservoir and cap from the airplane. Keep the reservoir and the cap.
  - (3) Install protective caps on all of the ports.
  - (4) Completely clean and flush the reservoir and the cap with Isopropyl Alcohol.
- E. (Refer to Figure 1, Detail A and Detail D, Sheets 5, 6, and 7.) Do the modification of the pilot's foot rest assembly as follows:
- (1) Do the trimming of the foot rest assembly to the correct dimensions.
  - (2) Drill a Number 10 (0.193-inch diameter) hole in the foot rest assembly at the location shown. For this modification, edge distance, measured from the centerline of the hole to the nearest edge of the part, is to be a minimum of 1.5 times the diameter of the fastener.
  - (3) Deburr and smooth corners, and apply Alodine to bare metal.
  - (4) With a permanent marker, make a mark through the existing part number on the foot rest assembly and write a new part number on the foot rest assembly adjacent to the old part number as follows:
    - (a) If the foot rest assembly that you removed from the airplane has a part number of 2613195-22, write 2691034-1 on the foot rest assembly.
    - (b) If the foot rest assembly that you removed from the airplane has a part number of 2613195-200, write 2691034-2 on the foot rest assembly.
    - (c) If the foot rest assembly that you removed from the airplane has a part number of 2613464-1, write 2691034-3 on the foot rest assembly.
- F. (Refer to Figure 1, Detail A and Detail B.) To make the 2691034-12 Forward Cover, do the modification of the 2613259-4 Forward Cover adjacent to the pilot's foot rest as follows:
- (1) Do the trimming of the 2613259-4 Cover to the correct dimension.
  - (2) Apply Alodine to bare metal.

- (3) With a permanent marker, make a mark through the 2613259-4 part number on the cover.
  - (4) Adjacent to the old part number on the cover, write 2691034-12.
- G. (Refer to Figure 1, Detail A and Detail C.) To make the 2691034-10 Access Cover, do the modification of the 2613259-1 Access Cover adjacent to the pilot's foot rest as follows:
- (1) Carefully remove and keep the outboard MS21047L3 Nutplate (the one closest to the pilot's foot rest assembly) from the 2613259-1 Cover. You will install it **inboard** of the location where you just removed it.
  - (2) Make a mark for and drill a No. 10 (0.193-inch diameter) hole in the cover at the correct location.
  - (3) Make a mark for and drill a dimpled No. 40 (0.098-inch diameter) hole in the cover at the correct location.
  - (4) Apply Alodine to bare metal.
  - (5) With two MS20426AD3-4A Rivets, install the kept MS21047L3 Nutplate.
  - (6) With one MS20426AD3-3A Rivet and one MS20426AD6-5A Rivet, plug the two holes where you removed the MS21047L3 Nutplate.
  - (7) With a permanent marker, make a mark through the 2613259-1 part number on the cover.
  - (8) Adjacent to the old part number on the cover, write 2691034-10.
- H. Remove the left and the right brake master cylinders. Keep the attachment hardware, but discard the cotter pins. (Refer to the Model 208 Maintenance Manual, Chapter 32, Brake Master Cylinder - Maintenance Practices.)
- I. Disassemble the left and the right brake master cylinders. (Refer to the Model 208 Maintenance Manual, Chapter 32, Brake Master Cylinder - Maintenance Practices.)
- J. With Isopropyl Alcohol, hand clean the parts that follow and then allow them to air dry: (Refer to the Model 208 Maintenance Manual, Chapter 32, Brake Master Cylinder - Maintenance Practices and the Model 208 Illustrated Parts Catalog, Chapter 32, 32-41-01 Figure 01 - Brake Master Cylinder Assembly.)
- 2682001-3 Brake Cylinder Body - hand clean the inside diameter and ports
  - 0541144 Brake Cylinder Rod - hand clean all surfaces
  - 2682001-2 Brake Cylinder Plug - hand clean all surfaces
  - 0541149 Sleeve - hand clean all surfaces
  - 5044000-3 Brake Cylinder Piston - hand clean all surfaces
  - NAS1149FN632P Washer - hand clean all surfaces.
- K. Remove and replace the parts that follow: (Refer to the Model 208 Maintenance Manual, Chapter 32, Brake Master Cylinder - Maintenance Practices and the Model 208 Illustrated Parts Catalog, Chapter 32, 32-41-01 Figure 01 - Brake Master Cylinder Assembly.)
- 0541148 Spring
  - 22FH632 Nut
  - MS28775-112 O-ring
  - 600-0115-6 Stat-O-Seal
  - MS28775-016 O-ring
  - MS28775-110 O-ring
  - S1628-110 Back Up Ring
  - 0541148-2 Spring.
- L. Reassemble the left and the right brake master cylinders. (Refer to the Model 208 Maintenance Manual, Chapter 32, Brake Master Cylinder - Maintenance Practices.)
- (1) (Refer to Figure 2.) The stat-o-seal gap adjustment during the reassembly must be done correctly. Compress the piston against the nut to allow the spring to compress while you tighten until the clearance between the piston and the stat-o-seal is 0.040 inch, +0.005 or

- 0.005 inch. (Refer to the Model 208 Maintenance Manual, Chapter 32, Brake Master Cylinder - Maintenance Practices.)
- (2) (Refer to Figure 1, Detail A and View A-A.) On the left and on the right pilot's master cylinders, make sure that the 0541140 Clevis is correctly installed to the 2682001-1 Brake Master Cylinder Assembly as follows: (Refer to the Model 208 Maintenance Manual, Chapter 32, Brake Master Cylinder - Maintenance Practices and the Model 208 Illustrated Parts Catalog, Chapter 32, Brake Master Cylinder Assembly.)
- (a) Apply Locquic Primer T to the rod threads of the 2682001-1 Brake Master Cylinder Assembly. If primer is not available, clean threads with Isopropyl Alcohol. (Refer to the Model 208 Maintenance Manual, Chapter 20, Anaerobic Adhesives - Maintenance Practices.)
  - (b) Allow the Locquic Primer T or Isopropyl Alcohol to dry.
  - (c) Apply Loctite 222 (or Loctite 242) Anaerobic Adhesive to the rod threads of the 2682001-1 Brake Master Cylinder Assembly. Make sure that the adhesive does not run down the rod shaft or on to the brake master cylinder rod shaft seal. (Refer to the Model 208 Maintenance Manual, Chapter 20, Anaerobic Adhesives - Maintenance Practices.)
  - (d) Hand thread the kept AN316-4R Jam Nut on to the rod threads of the 2682001-1 Brake Master Cylinder Assembly until it bottoms out.
  - (e) Hand thread the kept 0541140 Clevis on to the rod threads of the 2682001-1 Brake Master Cylinder Assembly to engage a minimum of seven threads.
  - (f) Hold the 0541140 Clevis to make sure that it does not turn while you tighten the AN316-4R Jam Nut to 35 inch pounds.
  - (g) Remove excess Locquic Primer T and Loctite Anaerobic Adhesive from the rod on the 2682001-1 Brake Master Cylinder Assembly.
- M. Remove the left and the right brake calipers. (Refer to the Model 208 Maintenance Manual, Chapter 32, Wheels and Brakes - Maintenance Practices.)
- N. Disassemble the left and the right brake calipers. (Refer to the Model 208 Maintenance Manual, Chapter 32, Wheels and Brakes - Maintenance Practices.)
- O. With Isopropyl Alcohol, hand clean and flush the parts that follow and let them air dry: (Refer to the Model 208 Maintenance Manual, Chapter 32, Wheels and Brakes - Maintenance Practices and the Model 208 Illustrated Parts Catalog, Chapter 32, 32-40-00 Figure 03 - Main Wheel Brake Assembly.)
- 061-11800 Brake Cylinder - Flush and hand clean all piston bores and flush all internal fluid passages
  - 092-06700 Brake Piston Assemblies, quantity four - hand clean all surfaces.
- P. Replace the MS28775-224 O-rings on the left and the right brake calipers. (Refer to the Model 208 Maintenance Manual, Chapter 32, Wheels and Brakes - Maintenance Practices and the Model 208 Illustrated Parts Catalog, Chapter 32, 32-40-00 Figure 03 - Main Wheel Brake Assembly.)
- Q. Reassemble the left and the right brake calipers. (Refer to the Model 208 Maintenance Manual, Chapter 32, Wheels and Brakes - Maintenance Practices.)
- R. Before installation of the removed assemblies and parts, do the hydraulic flush procedure that follows:
- NOTE:** In this flush procedure, you will use three AN815-3D Union Fittings (or equivalent 3/16 union flared fittings) as temporary maintenance connections.
- (1) (Refer to Figure 1, View A-A.) With one AN815-3D Union Fitting, connect the pilot's right brake master cylinder fluid inlet hose to the right brake master cylinder fluid outlet hose.
  - (2) With one AN815-3D Union Fitting, connect the pilot's left brake master cylinder fluid inlet hose to the left brake master cylinder fluid outlet hose.

- (3) With one AN815-3D Union Fitting, connect the hydraulic pressure source to the AN833-3D Line Nut Fitting that attached to the brake reservoir before you removed it. You can use a hand pump or a hydro-fill unit or equivalent as the hydraulic pressure source.
  - (4) Put the left and the right hoses that connected to the brake calipers into two clean containers that have more than a two-quart capacity.  
**NOTE:** These two containers will hold the hydraulic fluid that will be flushed through the system in the steps that follow.
  - (5) Fill the hydraulic pressure source with a minimum of two quarts of new hydraulic fluid that meets MIL-PRF-5606 specifications.
  - (6) Make sure that the parking brake valve is in the brakes-on (valve closed) position.
  - (7) Pressurize the external hydraulic pressure source to its maximum pressure. Do not exceed a maximum pressure of 1000 PSI.
  - (8) Put the parking brake valve in the brakes-off (valve open) position.
  - (9) Let the two quarts of hydraulic fluid flush through the system and discard the hydraulic fluid that you flushed through the system.
  - (10) Remove the hydraulic fluid pressure source.
  - (11) Disconnect and remove the three temporary AN815-3D Union Fittings.
- S. At the brake reservoir, remove and discard the MS28778-3 O-ring in the AN833-3D Line Nut Fitting and install a new MS28778-3 O-ring.
- T. Install the kept brake reservoir, connect the AN833-3D Line Nut Fitting, and replace the MS3367-2-9 Mounting Strap.
- U. Install the left and the right brake calipers and connect the hoses. (Refer to the Model 208 Maintenance Manual, Chapter 32, Wheels and Brakes - Maintenance Practices.)
- V. (Refer to Figure 1, Detail A, View A-A, View B-B, and View C-C.) Do the modification of the brake system to add the brake return spring assemblies as follows:
- (1) (Refer to Figure 1, Detail A, View B-B.) From the pilot's left rudder pedal assembly, remove and discard the two AN3-16A Bolts, NAS1149F0332P Washers, and MS21044N3 Nuts that attach the 2613166-1 Bearing Assembly (outboard) to the 2613017 Torque Tube Assembly. Do not remove the upper half or the lower half of the 2613166-1 Bearing Assembly.
  - (2) Put the 2682005-7 Outboard Return Spring Support in installation position on the 2613166-1 Bearing Assembly.
  - (3) With two AN3-21A Bolts, NAS1149F0332P Washers, and MS21044N3 Nuts, install the 2682005-7 Outboard Return Spring Support on the 2613166-1 Bearing Assembly.
  - (4) Torque the AN3-21A Bolts to between 20 inch-pounds and 25 inch-pounds.
  - (5) (Refer to Figure 1, Detail A, View C-C.) From the pilot's right rudder pedal assembly, remove and discard the two AN3-16A Bolts, NAS1149F0332P Washers, and MS21044N3 Nuts that attach the 2613166-2 Bearing Assembly (inboard) to the 2613017 Torque Tube Assembly. Do not remove the upper half of the 2613166-2 Bearing Assembly.
  - (6) Put the 2682005-15 Inboard Return Spring Support in installation position on the 2613166-2 Bearing Assembly.
  - (7) With two AN3-21A Bolts, NAS1149F0332P Washers, and MS21044N3 Nuts, install the 2682005-15 Inboard Return Spring Support on the 2613166-2 Bearing Assembly.
  - (8) Torque the AN3-21A Bolts to between 20 inch-pounds and 25 inch-pounds.



- (9) (Refer to Figure 1, Detail A and View A-A.) With the kept MS20392-2C17 Upper Pin and NAS1149F0332P Washer, and new MS24665-132 Cotter Pin, install the 0541140 Clevis on the 2682001-1 Brake Master Cylinder Assembly to the pilot's left rudder pedal.
- (10) (Refer to Figure 1, Detail A and View A-A.) With the kept MS20392-2C17 Upper Pin and NAS1149F0332P Washer, and new MS24665-132 Cotter Pin, install the 0541140 Clevis on the 2682001-1 Brake Master Cylinder Assembly to the pilot's right rudder pedal.

**CAUTION:** Do not use bolts that have a shorter grip length. Do not over tighten the NAS6203-13D Bolts. The brake return spring assembly must pivot within the lower clevis mount.

- (11) (Refer to Figure 1, View A-A and View B-B.) With an NAS6203-13D Bolt, NAS1149F0332P Washer, MS17825-3 Nut, and MS24665-132 Cotter Pin, install the 2682005-9 Brake Return Spring Assembly to the 2682005-7 Outboard Return Spring Support.
- (12) Tighten but do not overtighten the NAS6203-13D Bolt. As you tighten, make sure that the NAS6203-13D Bolt does not clamp and/or inhibit the motion of the brake master cylinder or brake return assembly at the lower mounting lugs or the upper clevis openings at the rudder pedal attachment.
- (13) (Refer to Figure 1, Detail A and View A-A.) Put the upper clevis of the 2682005-9 Brake Return Spring Assembly in installation position on the outboard rudder pedal.
- (14) With an AN3-7 Bolt, NAS1149F0332P Washer, MS17825-3 Nut, and MS24665-132 Cotter Pin, attach the 2682005-9 Brake Return Spring Assembly to the 2613162 Bracket on the outboard rudder pedal.
- (15) Tighten but do not overtighten the AN3-7 Bolt. As you tighten, make sure that the AN3-7 Bolt does not clamp and/or inhibit the motion of the brake master cylinder or brake return assembly at the lower mounting lugs or the upper clevis openings at the rudder pedal attachment.

**CAUTION:** Do not use bolts that have a shorter grip length. Do not over tighten the NAS6203-13D Bolts. The brake return spring assembly must pivot within the lower clevis mount.

- (16) (Refer to Figure 1, View A-A and View C-C.) With an NAS6203-13D Bolt, NAS1149F0332P Washer, MS17825-3 Nut, and MS24665-132 Cotter Pin, install the 2682005-9 Brake Return Spring Assembly to the 2682005-15 Inboard Return Spring Support.
- (17) Tighten but do not overtighten the NAS6203-13D Bolt. As you tighten, make sure that the NAS6203-13D Bolt does not clamp and/or inhibit the motion of the brake master cylinder or brake return assembly at the lower mounting lugs or the upper clevis openings at the rudder pedal attachment.
- (18) (Refer to Figure 1, Detail A and View A-A.) Put the upper clevis of the 2682005-9 Brake Return Spring Assembly in installation position on the inboard rudder pedal.
- (19) With an AN3-7 Bolt, NAS1149F0332P Washer, MS17825-3 Nut, and MS24665-132 Cotter Pin, attach the 2682005-9 Brake Return Spring Assembly to the 2613162 Bracket on the inboard rudder pedal.
- (20) Tighten but do not overtighten the AN3-7 Bolt. As you tighten, make sure that the AN3-7 Bolt does not clamp and/or inhibit the motion of the brake master cylinder or brake return assembly at the lower mounting lugs or the upper clevis openings at the rudder pedal attachment.
- (21) With two new MS24665-132 Cotter Pins, four new MS28778-3 O-rings, and the kept hardware, finish the installation of the pilot's left and right brake master cylinder. (Refer to the Model 208 Maintenance Manual, Chapter 32, Brake Master Cylinder - Maintenance Practices.)

**WARNING:** Do the Brake System Bleeding procedure exactly as stated in the Model 208 Maintenance Manual. If you do not use the Brake System Bleeding procedure exactly as stated in the Model 208 Maintenance Manual, you will not validate correct brake master cylinder function.

- (22) Do the servicing of the brake system with new hydraulic fluid that meets MIL-PRF-5606 specifications. You must follow the instructions that follow as you do the servicing of the brake system: (Refer to the Model 208 Maintenance Manual, Chapter 32, Wheels and Brakes - Maintenance Practices.)
- Make sure that you do the servicing in accordance with the Brake System Bleeding procedure in the Model 208 Maintenance Manual.
  - If the fluid level does not rise to the MAX line in the reservoir without toe brake pedal manipulation, you must contact your Cessna service representative for instructions before further flight.
  - Do not manipulate the toe brake pedals while you do the servicing of the brake system. The fluid level must rise in the reservoir to the MAX line without toe brake pedal manipulation. Fluid rise **without manipulation of the toe brake pedals** validates correct brake master cylinder function.
  - Do not service and / or bleed the brake system from the reservoir-down by pumping of the brakes.
- (23) Do a test to make sure that the brake return spring assemblies have been installed correctly as follows:
- (a) Fully actuate and then release the pilot's left toe brake.
  - (b) Make sure that after you release the pilot's left toe brake, the return spring assembly puts the left toe brake in the brakes off position.
  - (c) Fully actuate and then release the pilot's right toe brake.
  - (d) Make sure that after you release the pilot's right toe brake, the return spring assembly puts the right toe brake in the brakes off position.
- W. (Refer to Figure 1, Detail A.) Install the parts that follow with the kept attachment hardware.
1. Install the 2691034-10 Cover.
  2. Install the 2691034-12 Cover.
  3. Install the pilot's 2691034-1, 2691034-2, or 2691034-3 Foot Rest Assembly on the airplane.
  4. Install the control column cover. (Refer to the Model 208 Maintenance Manual, Chapter 25, Floor Covering/Control Column Cover - Maintenance Practices.)
  5. If removed, install the panel 226A on the pedestal. (Refer to the Model 208 Maintenance Manual, Chapter 6, Access Plates and Panels Identification - Description and Operation.)
  6. Install the pilot's seat. (Refer to the Model 208 Maintenance Manual, Chapter 25, Flight Compartment - Maintenance Practices.)
- X. Do a check for correct operation of the rudders as follows:
- (1) Install a rudder travel protractor.
  - (2) Move the system through its full range of travel and make sure that all of the components that move do not hit, touch, or catch on structural components or other system components.
  - (3) With the nose wheel turning bar, turn the nose wheel left until the rudder stop block contacts the bolt and make sure that the rudder travel on the protractor is 25 +2 or -2 degrees.
  - (4) With the nose wheel turning bar, turn the nose wheel right until the rudder stop block contacts the bolt and make sure that the rudder travel on the protractor is 25 +2 or -2 degrees.

- (5) Turn the nose wheel to center and make sure that the rudder pedals and the rudder are centered.
  - (a) If the rudder pedals and the rudder are centered, remove the rudder travel protractor and go to Step 1Y.
  - (b) If the rudder pedals and the rudder are not centered, make sure that the nose gear steering rigging is correct. (Refer to the Model 208 Maintenance Manual, Chapter 32, Nose Gear Steering - Maintenance Practices.)
- (6) Remove the rudder travel protractor.
- Y. Remove maintenance warning tags and connect the airplane battery.
- Z. Do a Brakes Operational Check in accordance with the Model 208 Maintenance Manual. (Refer to the Model 208 Maintenance Manual, Chapter 32, Wheels and Brakes - Inspection/Check, Task 32-40-00-710.)
- AA. Go to Step 3 of this service bulletin.
2. Group B airplanes do as follows:
  - A. Prepare the airplane for maintenance.
    - (1) Electrically ground the airplane.
    - (2) Make sure that all switches are in the OFF/NORM position.
    - (3) Disconnect electrical power from the airplane.
      - (a) Disconnect external electrical power.
      - (b) Disconnect the airplane battery.
  - B. Remove the parts that follow from the airplane:
    1. Remove the pilot's seat. (Refer to the Model 208 Maintenance Manual, Chapter 25, Flight Compartment - Maintenance Practices.)
    2. Remove the control column cover. (Refer to the Model 208 Maintenance Manual, Chapter 25, Floor Covering/Control Column Cover - Maintenance Practices.)
    3. As necessary, remove panel 226A from the pedestal. (Refer to the Model 208 Maintenance Manual, Chapter 6, Access Plates and Panels Identification - Description and Operation.)
    4. (Refer to Figure 1, Detail A and Detail D, Sheets 5, 6, and 7.) Remove the pilot's foot rest assembly from the airplane. Keep the foot rest assembly and the attachment hardware.
    5. (Refer to Figure 1, Detail A and Detail B.) Remove the 2613259-4 Cover. Keep the cover and the attachment hardware.
    6. (Refer to Figure 1, Detail A and Detail C.) Remove the 2613259-1 Cover. Keep the cover and the attachment hardware.
  - C. (Refer to Figure 1, Detail A and Detail D, Sheets 5, 6, and 7.) Do the modification of the pilot's foot rest assembly as follows:
    - (1) Do the trimming of the foot rest assembly to the correct dimensions.
    - (2) Drill a Number 10 (0.193-inch diameter) hole in the foot rest assembly at the location shown. For this modification, edge distance, measured from the centerline of the hole to the nearest edge of the part, is to be a minimum of 1.5 times the diameter of the fastener.
    - (3) Deburr and smooth corners, and apply Alodine to bare metal.

- (4) With a permanent marker, make a mark through the existing part number on the foot rest assembly and write a new part number on the foot rest assembly adjacent to the old part number as follows:
  - (a) If the foot rest assembly that you removed from the airplane has a part number of 2613195-22, write 2691034-1 on the foot rest assembly.
  - (b) If the foot rest assembly that you removed from the airplane has a part number of 2613195-200, write 2691034-2 on the foot rest assembly.
  - (c) If the foot rest assembly that you removed from the airplane has a part number of 2613464-1, write 2691034-3 on the foot rest assembly.
- D. (Refer to Figure 1, Detail A and Detail B.) To make the 2691034-12 Forward Cover, do the modification of the 2613259-4 Forward Cover adjacent to the pilot's foot rest as follows:
  - (1) Do the trimming of the 2613259-4 Cover to the correct dimension.
  - (2) Apply Alodine to bare metal.
  - (3) With a permanent marker, make a mark through the 2613259-4 part number on the cover.
  - (4) Adjacent to the old part number on the cover, write 2691034-12.
- E. (Refer to Figure 1, Detail A and Detail C.) To make the 2691034-10 Access Cover, do the modification of the 2613259-1 Access Cover adjacent to the pilot's foot rest as follows:
  - (1) Carefully remove and keep the outboard MS21047L3 Nutplate (the one closest to the pilot's foot rest assembly) from the 2613259-1 Cover. You will install it **inboard** of the location where you just removed it.
  - (2) Make a mark for and drill a No. 10 (0.193-inch diameter) hole in the cover at the correct location.
  - (3) Make a mark for and drill a dimpled No. 40 (0.098-inch diameter) hole in the cover at the correct location.
  - (4) Apply Alodine to bare metal.
  - (5) With two MS20426AD3-4A Rivets, install the kept MS21047L3 Nutplate.
  - (6) With one MS20426AD3-3A Rivet and one MS20426AD6-5A Rivet, plug the two holes where you removed the MS21047L3 Nutplate.
  - (7) With a permanent marker, make a mark through the 2613259-1 part number on the cover.
  - (8) Adjacent to the old part number on the cover, write 2691034-10.
- F. Remove the left and the right brake master cylinders. Do not remove the hydraulic hoses from the master cylinders. Keep the attachment hardware, but discard the cotter pins. (Refer to the Model 208 Maintenance Manual, Chapter 32, Brake Master Cylinder - Maintenance Practices.)
- G. (Refer to Figure 1, Detail A, View A-A, View B-B, and View C-C.) Do the modification of the brake system to add the brake return spring assemblies as follows:
  - (1) (Refer to Figure 1, Detail A, View B-B.) From the pilot's left rudder pedal assembly, remove and discard the two AN3-16A Bolts, NAS1149F0332P Washers, and MS21044N3 Nuts that attach the 2613166-1 Bearing Assembly (outboard) to the 2613017 Torque Tube Assembly. Do not remove the upper half of the 2613166-1 Bearing Assembly.
  - (2) Put the 2682005-7 Outboard Return Spring Support in installation position on the 2613166-1 Bearing Assembly.
  - (3) With two AN3-21A Bolts, NAS1149F0332P Washers, and MS21044N3 Nuts, install the 2682005-7 Outboard Return Spring Support on the 2613166-1 Bearing Assembly.
  - (4) Torque the AN3-21A Bolts to between 20 inch-pounds and 25 inch-pounds.

- (5) (Refer to Figure 1, Detail A, View C-C.) From the pilot's right rudder pedal assembly, remove and discard the two AN3-16A Bolts, NAS1149F0332P Washers, and MS21044N3 Nuts that attach the 2613166-2 Bearing Assembly (inboard) to the 2613017 Torque Tube Assembly. Do not remove the upper half of the 2613166-2 Bearing Assembly.
- (6) Put the 2682005-15 Inboard Return Spring Support in installation position on the 2613166-2 Bearing Assembly.
- (7) With two AN3-21A Bolts, NAS1149F0332P Washers, and MS21044N3 Nuts, install the 2682005-15 Inboard Return Spring Support on the 2613166-2 Bearing Assembly.
- (8) Torque the AN3-21A Bolts to between 20 inch-pounds and 25 inch-pounds.
- (9) (Refer to Figure 1, Detail A and View A-A.) On the left and on the right pilot's master cylinders, make sure that the 0541140 Clevis is correctly installed in the 2682001-1 Brake Master Cylinder Assemblies as follows: (Refer to the Model 208 Maintenance Manual, Chapter 32, Brake Master Cylinder - Maintenance Practices and the Model 208 Illustrated Parts Catalog, Chapter 32, Brake Master Cylinder Assembly.)
  - (a) From the left and the right pilot's rudder pedals, remove and keep the MS20392-2C17 Upper Pin and NAS1149F0332P Washer, and discard the MS24665-132 Cotter Pin that attach the 0541140 Clevis to the 2682001-1 Brake Master Cylinder Assembly.
  - (b) Loosen the jam nut and remove the 0541140 Clevis and the AN316-4R Jam Nut from the rod on the 2682001-1 Brake Master Cylinder Assembly.
  - (c) Apply Locquic Primer T to the rod threads of the 2682001-1 Brake Master Cylinder Assembly. If primer is not available, clean threads with Isopropyl Alcohol. (Refer to the Model 208 Maintenance Manual, Chapter 20, Anaerobic Adhesives - Maintenance Practices.)
  - (d) Allow the Locquic Primer T or Isopropyl Alcohol to dry.
  - (e) Apply Loctite 222 (or Loctite 242) Anaerobic Adhesive to the rod threads of the 2682001-1 Brake Master Cylinder Assembly. Make sure that the adhesive does not run down the rod shaft or on to the brake master cylinder rod shaft seal. (Refer to the Model 208 Maintenance Manual, Chapter 20, Anaerobic Adhesives - Maintenance Practices.)
  - (f) Hand thread the kept AN316-4R Jam Nut on to the rod threads of the 2682001-1 Brake Master Cylinder Assembly until it bottoms out.
  - (g) Hand thread the kept 0541140 Clevis on to the rod threads of the 2682001-1 Brake Master Cylinder Assembly to engage a minimum of seven threads.
  - (h) Hold the 0541140 Clevis to make sure that it does not turn while you tighten the AN316-4R Jam Nut to 35 inch pounds.
  - (i) Remove excess Locquic Primer T and Loctite Anaerobic Adhesive from the rod on the 2682001-1 Brake Master Cylinder Assembly.
  - (j) With the kept MS20392-2C17 Upper Pin and NAS1149F0332P Washer, and the new MS24665-132 Cotter Pin, install the 0541140 Clevis on the 2682001-1 Brake Master Cylinder Assembly to the pilot's left rudder pedal.
  - (k) With the kept MS20392-2C17 Upper Pin and NAS1149F0332P Washer, and the new MS24665-132 Cotter Pin, install the 0541140 Clevis on the 2682001-1 Brake Master Cylinder Assembly to the pilot's right rudder pedal.

**CAUTION:** Do not use bolts that have a shorter grip length. Do not over tighten the NAS6203-13D Bolts. The brake return spring assembly must pivot within the lower clevis mount.
- (10) (Refer to Figure 1, View A-A and View B-B.) With an NAS6203-13D Bolt, NAS1149F0332P Washer, MS17825-3 Nut, and MS24665-132 Cotter Pin, install the 2682005-9 Brake Return Spring Assembly to the 2682005-7 Outboard Return Spring Support.

- (11) Tighten but do not overtighten the NAS6203-13D Bolt. As you tighten, make sure that the NAS6203-13D Bolt does not clamp and/or inhibit the motion of the brake return assembly at the lower mounting lugs or the upper clevis openings at the rudder pedal attachment.
- (12) (Refer to Figure 1, Detail A and View A-A.) Put the upper clevis of the 2682005-9 Brake Return Spring Assembly in installation position on the outboard rudder pedal.
- (13) With an AN3-7 Bolt, NAS1149F0332P Washer, MS17825-3 Nut, and MS24665-132 Cotter Pin, attach the 2682005-9 Brake Return Spring Assembly to the 2613162 Bracket on the outboard rudder pedal.
- (14) Tighten but do not overtighten the AN3-7 Bolt. As you tighten, make sure that the AN3-7 Bolt does not clamp and/or inhibit the motion of the brake return assembly at the lower mounting lugs or the upper clevis openings at the rudder pedal attachment.

**CAUTION:** Do not use bolts that have a shorter grip length. Do not over tighten the NAS6203-13D Bolts. The brake return spring assembly must pivot within the lower clevis mount.

- (15) (Refer to Figure 1, View A-A and View C-C.) With an NAS6203-13D Bolt, NAS1149F0332P Washer, MS17825-3 Nut, and MS24665-132 Cotter Pin, install the 2682005-9 Brake Return Spring Assembly to the 2682005-15 Inboard Return Spring Support.
  - (16) Tighten but do not overtighten the NAS6203-13D Bolt. As you tighten, make sure that the NAS6203-13D Bolt does not clamp and/or inhibit the motion of the brake return assembly at the lower mounting lugs or the upper clevis openings at the rudder pedal attachment.
  - (17) (Refer to Figure 1, Detail A and View A-A.) Put the upper clevis of the 2682005-9 Brake Return Spring Assembly in installation position on the inboard rudder pedal.
  - (18) With an AN3-7 Bolt, NAS1149F0332P Washer, MS17825-3 Nut, and MS24665-132 Cotter Pin, attach the 2682005-9 Brake Return Spring Assembly to the 2613162 Bracket on the inboard rudder pedal.
  - (19) Tighten but do not overtighten the AN3-7 Bolt. As you tighten, make sure that the AN3-7 Bolt does not clamp and/or inhibit the motion of the brake return assembly at the lower mounting lugs or the upper clevis openings at the rudder pedal attachment.
  - (20) Do a test to make sure that the brake return spring assemblies have been installed correctly as follows:
    - (a) Fully actuate and then release the pilot's left toe brake.
    - (b) Make sure that after you release the pilot's left toe brake, the brake return spring assembly puts the left toe brake in the brakes off position.
    - (c) Fully actuate and then release the pilot's right toe brake.
    - (d) Make sure that after you release the pilot's right toe brake, the brake return spring assembly puts the right toe brake in the brakes off position.
- H. (Refer to Figure 1, Detail A.) Install the parts that follow with the kept attachment hardware.
1. Install the 2691034-10 Cover.
  2. Install the 2691034-12 Cover.
  3. Install the pilot's 2691034-1, 2691034-2, or 2691034-3 Foot Rest Assembly on the airplane.
  4. Install the control column cover. (Refer to the Model 208 Maintenance Manual, Chapter 25, Floor Covering/Control Column Cover - Maintenance Practices.)
  5. If removed, install the panel 226A on the pedestal. (Refer to the Model 208 Maintenance Manual, Chapter 6, Access Plates and Panels Identification - Description and Operation.)
  6. Install the pilot's seat. (Refer to the Model 208 Maintenance Manual, Chapter 25, Flight Compartment - Maintenance Practices.)

- I. Do a check for correct operation of the rudders as follows:
  - (1) Install a rudder travel protractor.
  - (2) Move the system through its full range of travel and make sure that all of the components that move do not hit, touch, or catch on structural components or other system components.
  - (3) With the nose wheel turning bar, turn the nose wheel left until the rudder stop block contacts the bolt and make sure that the rudder travel on the protractor is 25 +2 or -2 degrees.
  - (4) With the nose wheel turning bar, turn the nose wheel right until the rudder stop block contacts the bolt and make sure that the rudder travel on the protractor is 25 +2 or -2 degrees.
  - (5) Turn the nose wheel to center and make sure that the rudder pedals and the rudder are centered.
    - (a) If the rudder pedals and the rudder are centered, remove the rudder travel protractor and go to Step 2J.
    - (b) If the rudder pedals and the rudder are not centered, make sure that the nose gear steering rigging is correct. (Refer to the Model 208 Maintenance Manual, Chapter 32, Nose Gear Steering - Maintenance Practices.)
  - (6) Remove the rudder travel protractor.
- J. With a syringe or equivalent, remove half of the hydraulic fluid from the brake reservoir.
- K. Look at and record the level of hydraulic fluid remaining in the brake reservoir.

**WARNING:** Do the Brake System Bleeding procedure exactly as stated in the Model 208 Maintenance Manual. If you do not use the Brake System Bleeding procedure exactly as stated in the Model 208 Maintenance Manual, you will not validate correct brake master cylinder function.

- L. Do the servicing of the brake system with new hydraulic fluid that meets MIL-PRF-5606 specifications. You must follow the instructions that follow as you do the servicing of the brake system: (Refer to the Model 208 Maintenance Manual, Chapter 32, Wheels and Brakes - Maintenance Practices.)
    - Make sure that you do the servicing in accordance with the Brake System Bleeding procedure in the Model 208 Maintenance Manual.
    - If the fluid level does not rise to the MAX line in the reservoir without toe brake pedal manipulation, you must contact your Cessna service representative for instructions before further flight.
    - Do not manipulate the toe brake pedals while you do the servicing of the brake system. The fluid level must rise in the reservoir to the MAX line without toe brake pedal manipulation. Fluid rise without manipulation of the toe brake pedals validates correct brake master cylinder function.
    - Do not service and / or bleed the brake system from the reservoir-down by pumping of the brakes.
  - M. Remove maintenance warning tags and connect the airplane battery.
  - N. Do a Brakes Operational Check in accordance with the Model 208 Maintenance Manual. (Refer to the Model 208 Maintenance Manual, Chapter 32, Wheels and Brakes - Inspection/Check, Task 32-40-00-710.)
3. Make an entry in the airplane logbook that states compliance and method of compliance with this service bulletin.

**NOTE:** This information must be considered an amendment to the Cessna Manufacturer's Service/Maintenance Manual or Instructions for Continued Airworthiness and must be accomplished for ongoing airworthiness compliance as necessary in accordance with 14 CFR Part 43.13.

A92401

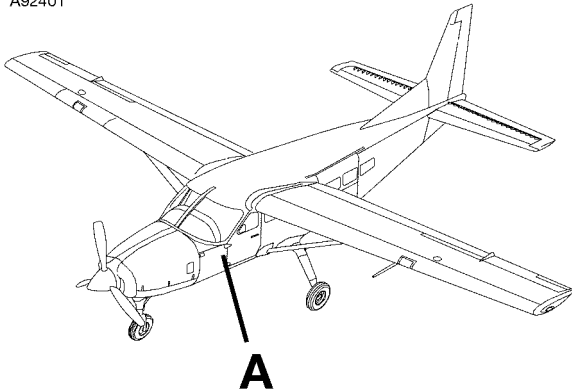

(2613259-1  
Before Modification)  
2691034-10  
Access Cover  
(After Modification)  
**(NOTE 3)**

Before Modification 2613195-22	After Modification 2691034-1
2613195-200	2691034-2
Or 2613464-1	Or 2691034-3

Pilot's Foot Rest Assembly  
**(NOTE 2)**

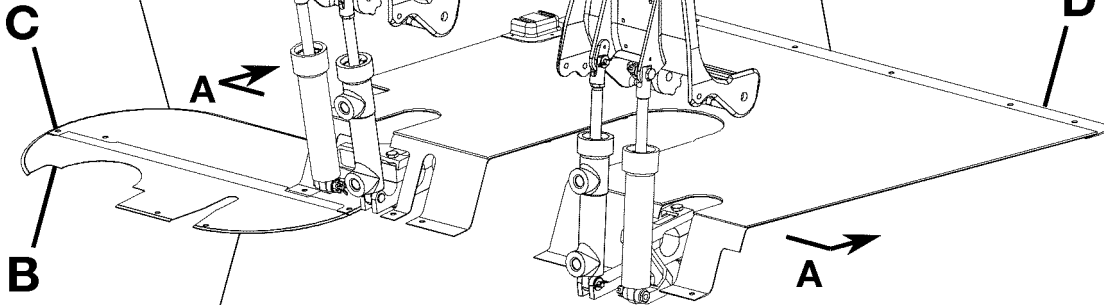

(2613259-4  
Before Modification)  
2691034-12  
Forward Cover  
(After Modification)  
**(NOTE 4)**

**DETAIL A**  
Pilot's Side

**NOTE 1:** All dimensions are shown in inches.

**NOTE 2:** Modify existing foot rest to make 2691034-1, 2691034-2, or 2691034-3 Pilot's Foot Rest Assembly.

**NOTE 3:** Modify existing 2613259-1 Access Cover to make 2691034-10 Access Cover.

**NOTE 4:** Modify existing 2613259-4 Forward Cover to make 2691034-12 Forward Cover.

2610T7002  
A2698192-1

Figure 1. Brake System Modification (Sheet 1)



A92402

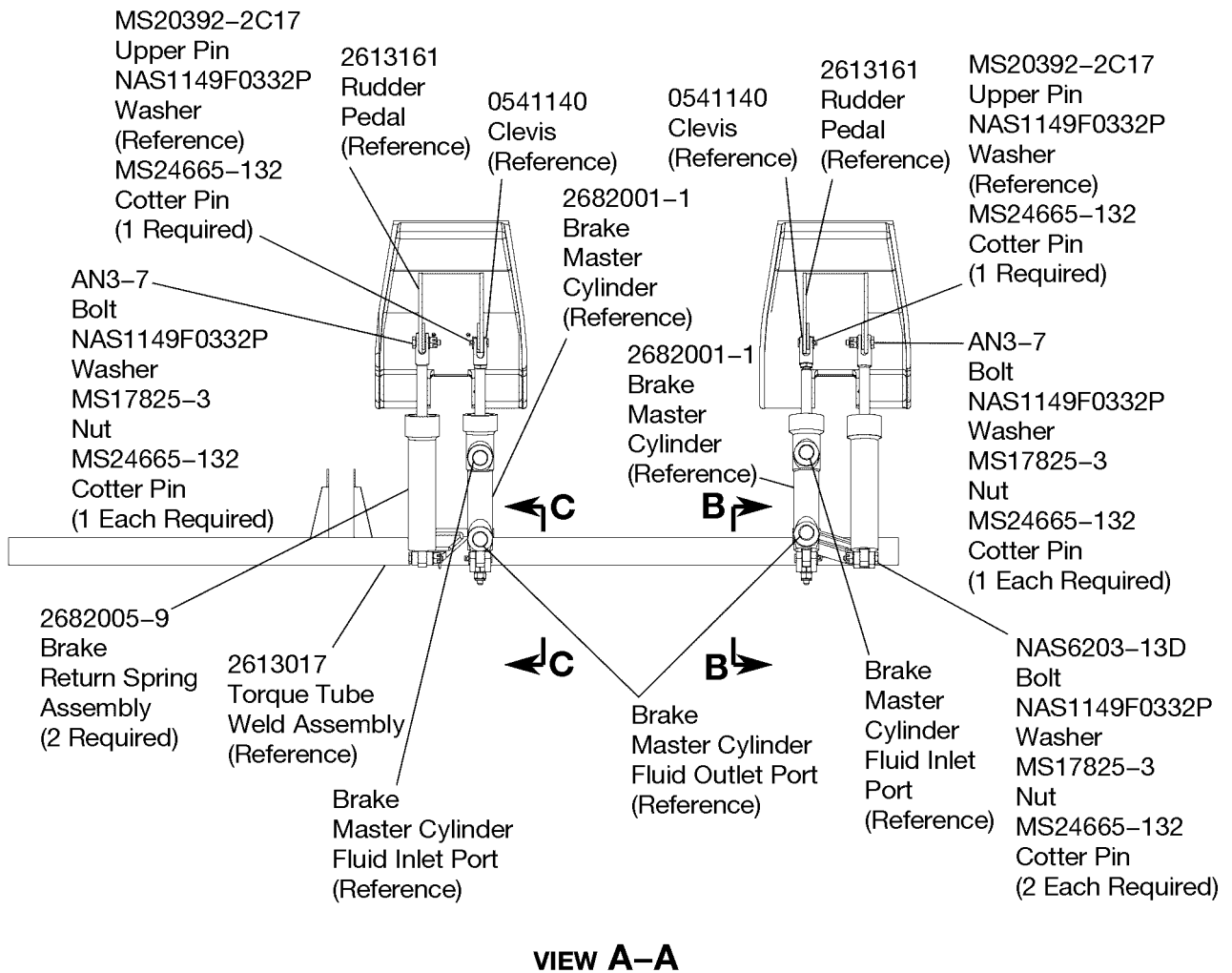

AA2698192-1

Figure 1. Brake System Modification (Sheet 2)

A92403

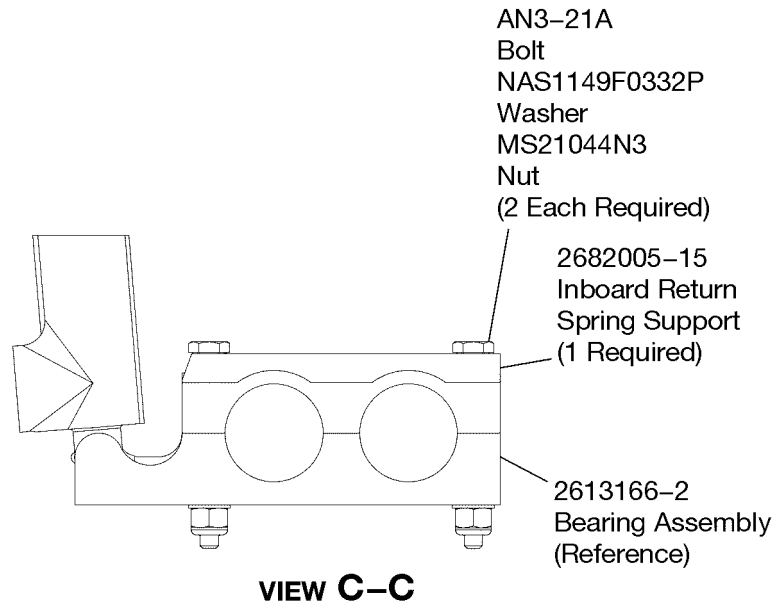
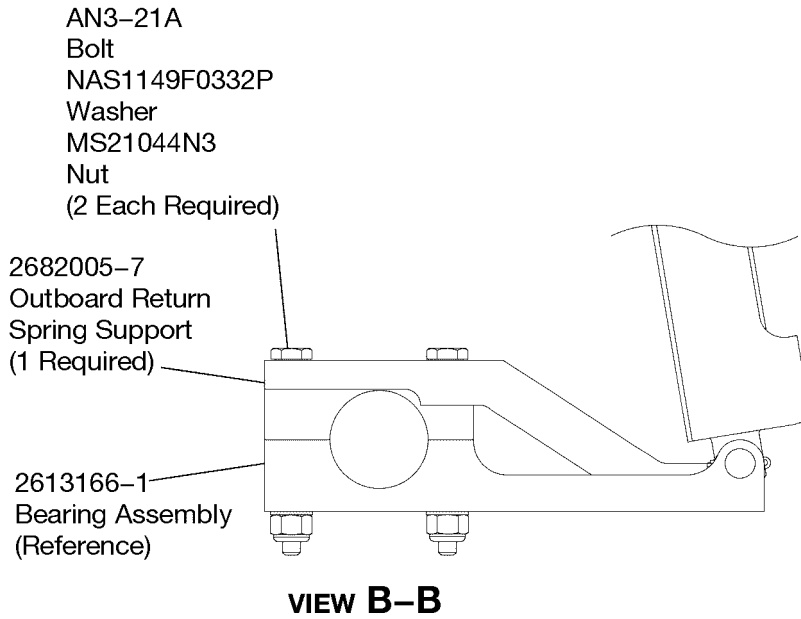

BB2698192-1  
CC2698192-1

Figure 1. Brake System Modification (Sheet 3)

A92404

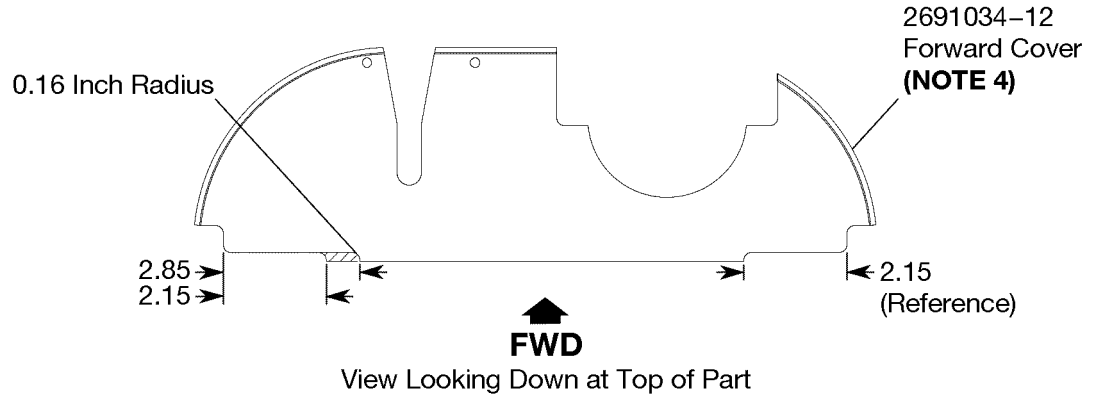

### DETAIL B

Modification of 2613259-4 Forward Cover to 2691034-12 Forward Cover

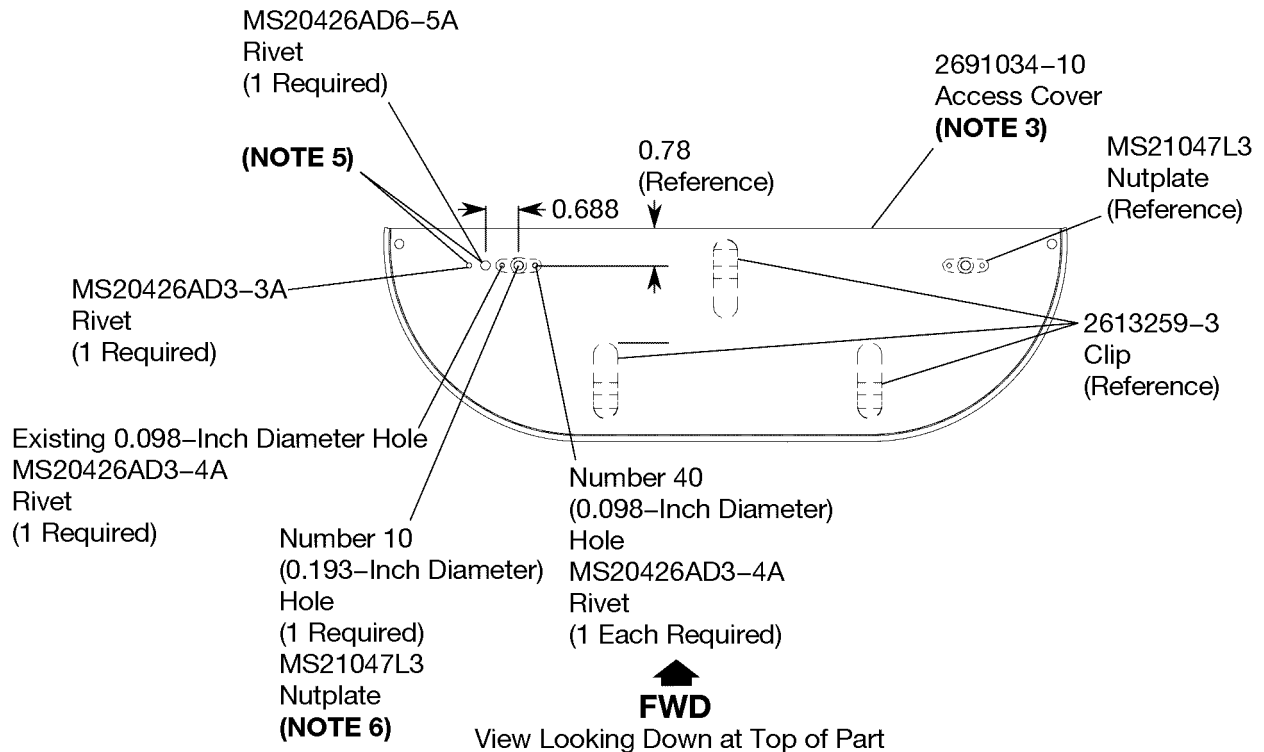

### DETAIL C

Modification of 2613259-1 Access Cover to 2691034-10 Access Cover

**NOTE 5:** Plug these holes with rivets shown.

**NOTE 6:** Keep nutplate and move to new location.

B2691034-12A  
C2691034-10A

Figure 1. Brake System Modification (Sheet 4)

A92405

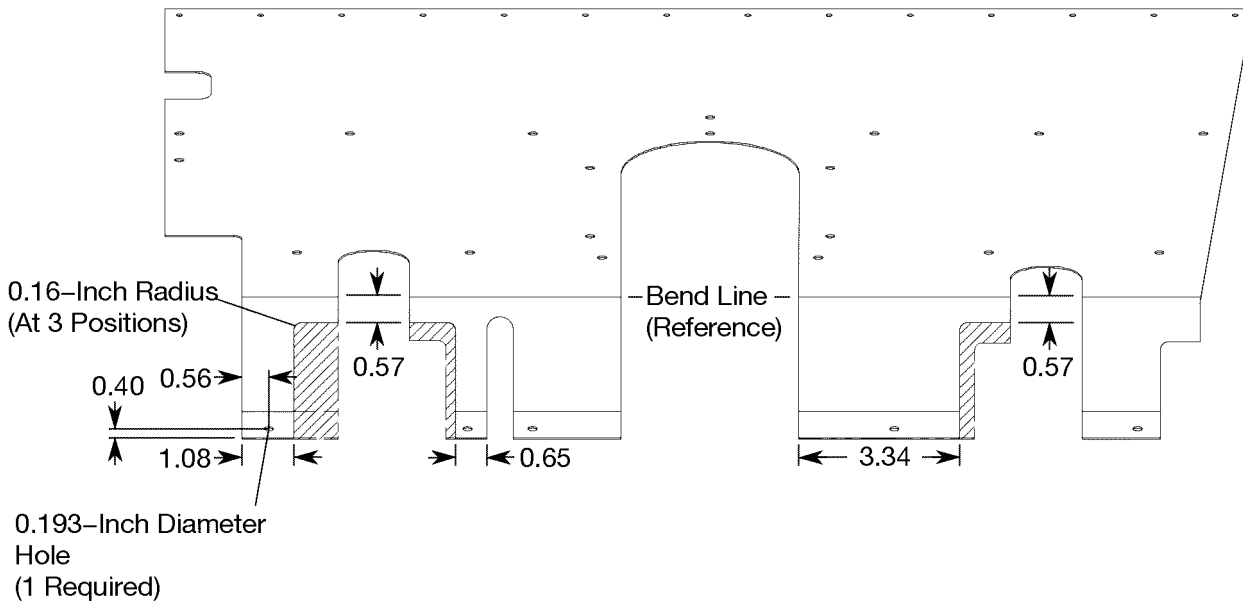

## DETAIL D

Modification of 2613195-22 Foot Rest Assembly to 2691034-1 Foot Rest Assembly



Indicates area to be removed.

DD2691034-7A

Figure 1. Brake System Modification (Sheet 5)

A92406

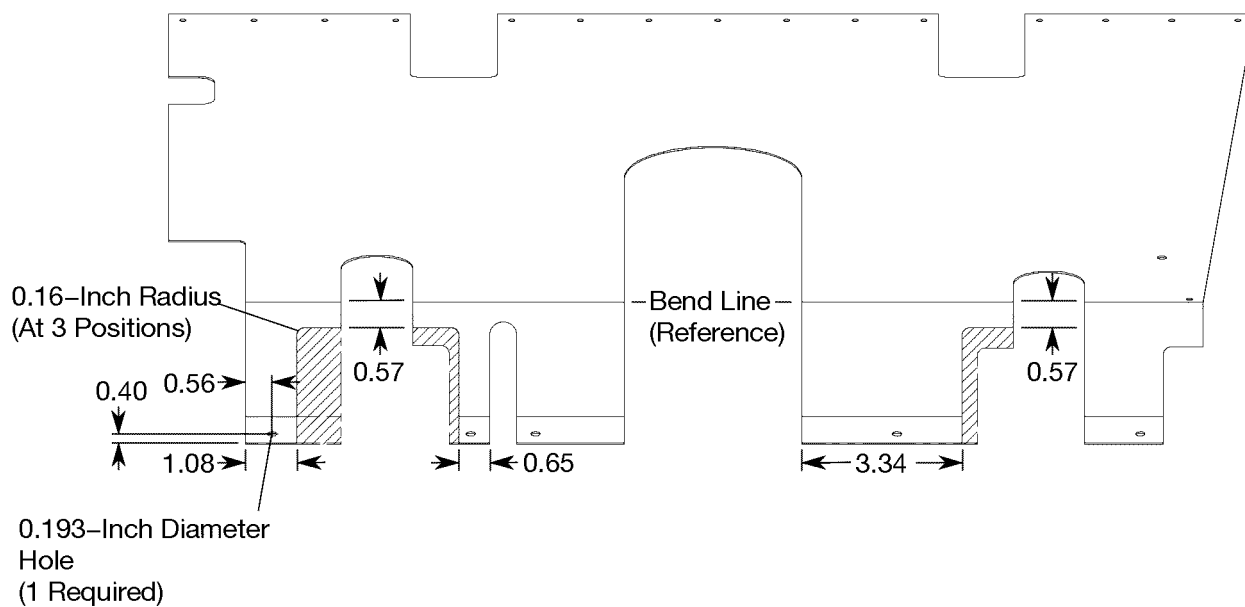

## DETAIL D

Modification of 2613195-200 Foot Rest Assembly to 2691034-2 Foot Rest Assembly

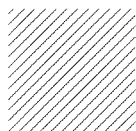

Indicates area to be removed.

DD2691034-8A

Figure 1. Brake System Modification (Sheet 6)

A92407

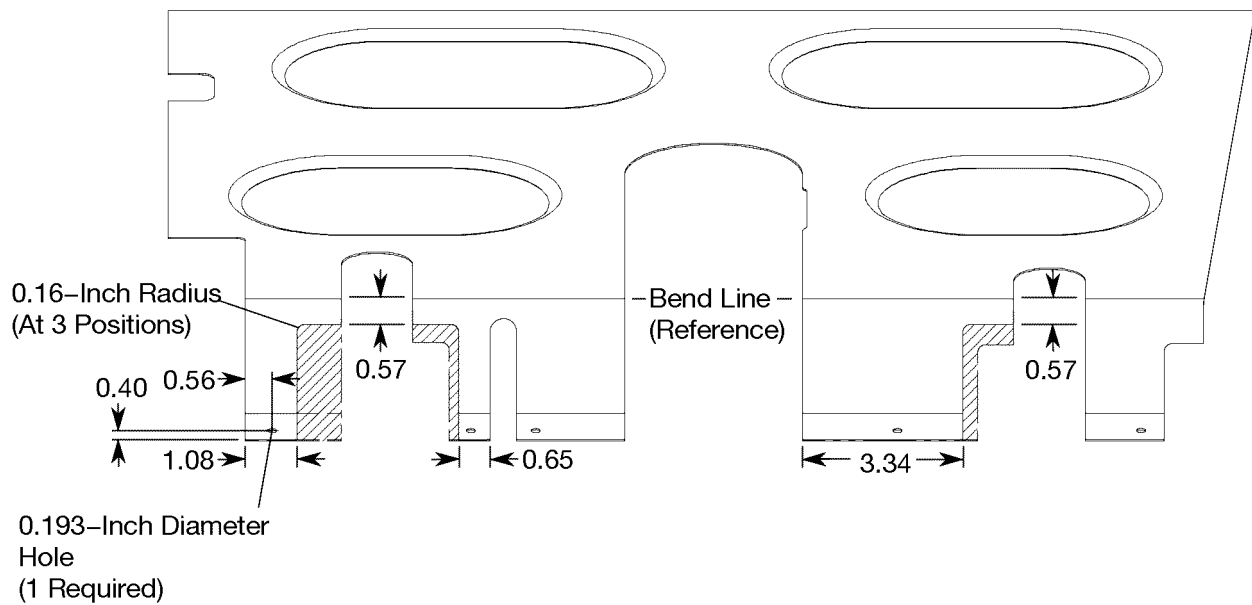

## DETAIL D

Modification of 2613464-1 Foot Rest Assembly to 2691034-3 Foot Rest Assembly

D2691034-9A

Figure 1. Brake System Modification (Sheet 7)

A93207

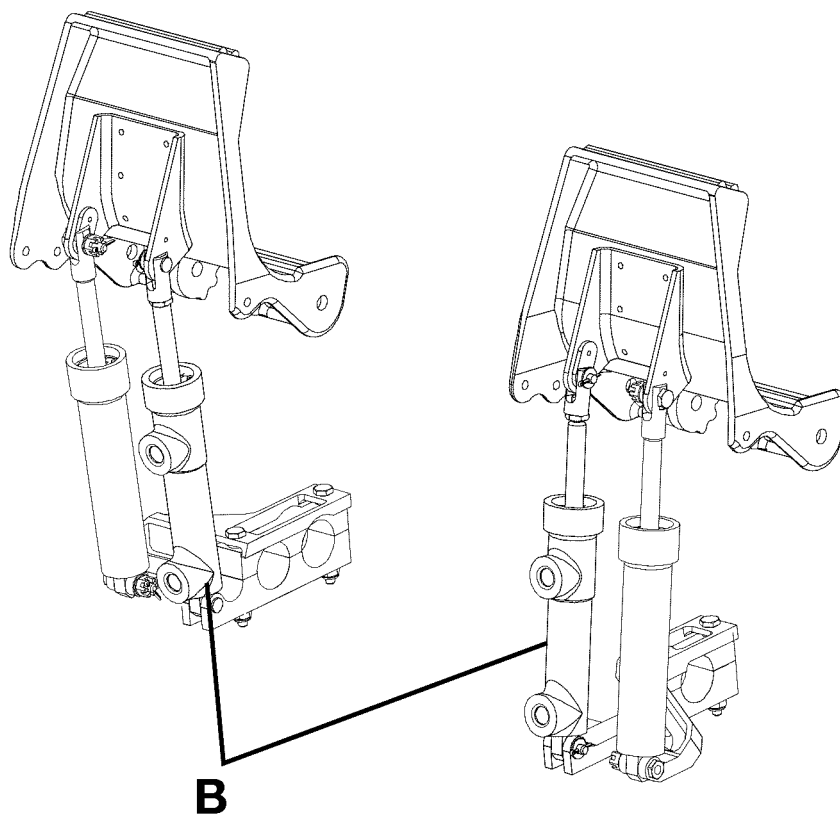
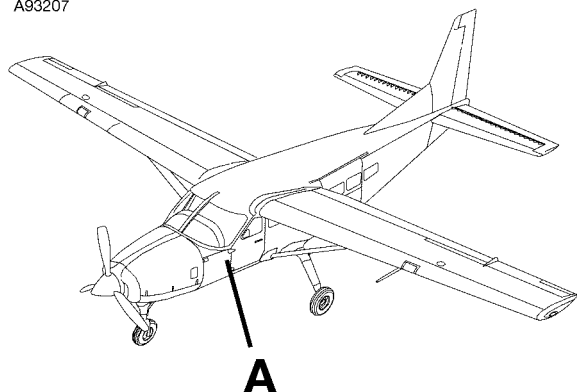

**DETAIL A**  
Pilot's Side

Figure 2. (Sheet 1)

2610T7002  
A2698192-1

A93208

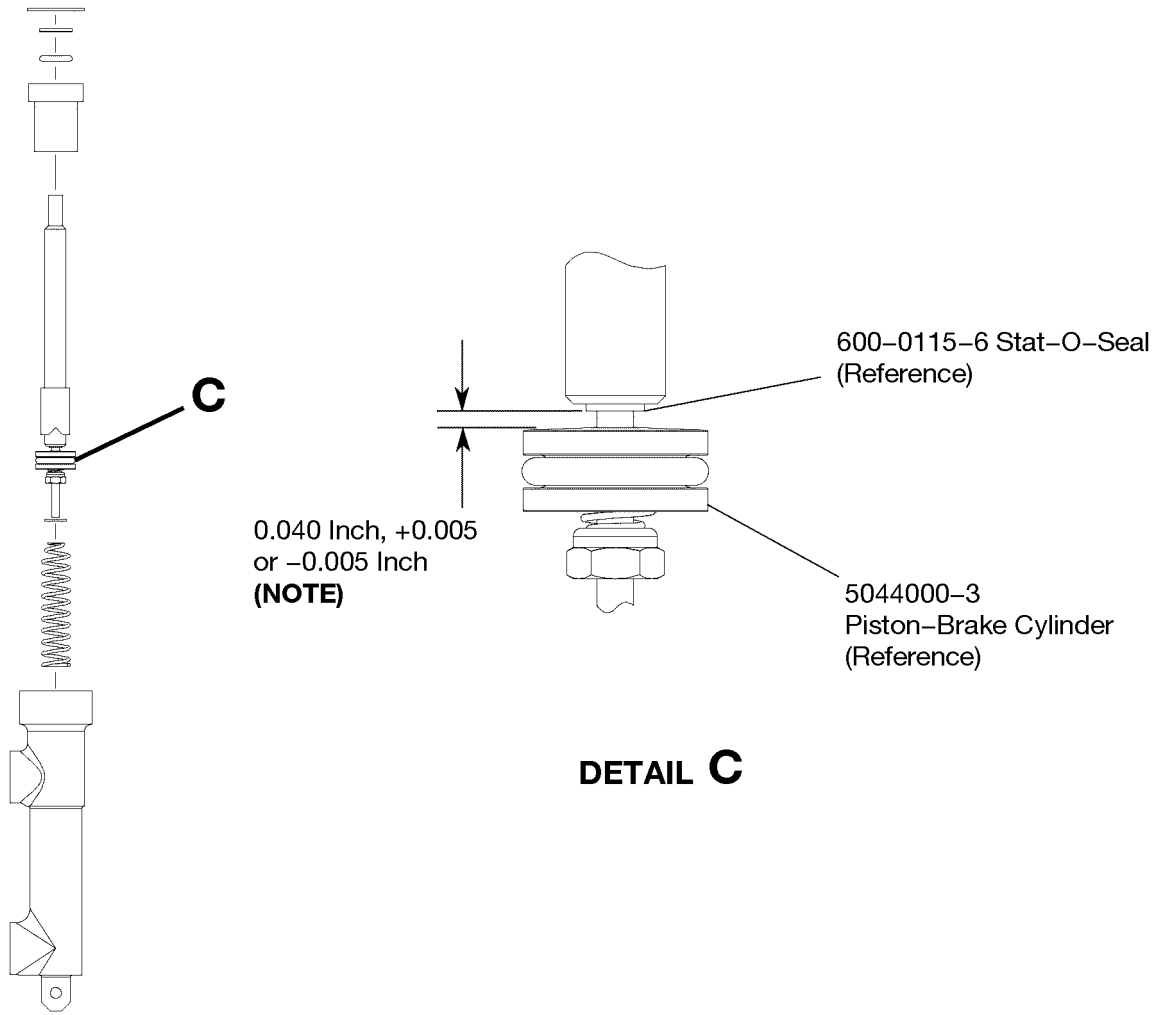

## DETAIL B

**NOTE:** Compress the piston against the nut to allow the spring to compress while you tighten until the clearance between the piston and stat-o-seal is 0.040 inch, +0.005 or -0.005 inch.

B2682001-1  
C2682001-1

Figure 2. (Sheet 2)



## MATERIAL INFORMATION

The parts that follow are available from Cessna Service Parts and Programs through a Cessna Authorized Service Facility and are necessary for Group A and Group B airplanes:

NEW P/N	QUANTITY	KEY WORD	OLD P/N	INSTRUCTIONS/ DISPOSITION
<b>CAB-32-01A</b>	1	<b>Kit</b> , consisting of the following parts:		
2682005-15	1	Inboard Return Spring Support	None	None
2682005-7	1	Outboard Return Spring Support	None	None
2682005-9	2	Brake Return Spring Assembly	None	None
CAB-32-01HW	1	Hardware Pack, consisting of the parts that follow: AN3-21A Bolt (4) AN3-7 Bolt (2) MS17825-3 Nut (4) MS20426AD3-3A Rivet (1) MS20426AD3-4A Rivet (2) MS20426AD6-5A Rivet (1) MS21044N3 Nut (4) MS24665-132 Cotter Pin (8) NAS1149F0332P Washer (8) NAS6203-13D Bolt (2)		
CAB-32-01A	1	Instructions		

In addition to CAB-32-01A, the parts that follow are also necessary for Group A airplanes:

NEW P/N	QUANTITY	KEY WORD	OLD P/N	INSTRUCTIONS/ DISPOSITION
MS28775-110	2	O-ring	Same	Discard
MS28775-112	2	O-ring	Same	Discard
MS28775-016	2	O-ring	Same	Discard
MS28775-224	8	O-ring	Same	Discard
MS28778-3	5	O-ring	Same	Discard
MS3367-2-9	1	Mounting Strap	Same	Discard

<b>NEW P/N</b>	<b>QUANTITY</b>	<b>KEY WORD</b>	<b>OLD P/N</b>	<b>INSTRUCTIONS/ DISPOSITION</b>
S1628-110	2	Ring	Same	Discard
0541148	2	Spring	Same	Discard
0541148-2	2	Spring	Same	Discard
22FH632	2	Nut	Same	Discard
600-0115-6	2	Stat-O-Seal	Same	Discard

**TITLE**

LANDING GEAR - BRAKE SYSTEM MODIFICATION AND CLEANSING PROCEDURE

**TO:**

Cessna Caravan Owner

**REASON**

This Owner Advisory is to inform you that CAB-32-01 Revision 1 has been issued.

CAB-32-01 Revision 1 provides parts and instructions to do a modification of the brake system to add brake return spring assemblies. For some airplanes, a cleansing of the brake system must also be accomplished.

**NOTE:** This revision replaces the Original Issue of CAB-32-01 in its entirety.

**NOTE:** The Original Issue of CAB-32-01 was never distributed by Cessna Aircraft Company.

**COMPLIANCE**

Mandatory: Shall be accomplished within 400 hours of operation or 18 months, whichever occurs first.

Compliance with CAB-32-01 Revision 1 is required if in compliance with the Original Issue.

**LABOR HOURS**

For Group A airplanes, 15.7 man-hours to accomplish this service bulletin

For Group B airplanes, 9.7 man-hours to accomplish this service bulletin

**CREDIT INFORMATION**

For all Group A airplanes identified within the serial number effectivity:

Applicable parts credit, a miscellaneous parts credit of \$20.00, and a labor allowance credit of 15.7 man-hours per airplane will be provided to accomplish this service bulletin.

For all Group B airplanes identified within the serial number effectivity:

Applicable parts credit and a labor allowance credit of 9.7 man-hours per airplane will be provided to accomplish this service bulletin.

Freight will be credited at the most economical method unless pre-approved by Cessna.

To receive credit, the work must be completed and a Warranty Claim submitted by a Cessna Caravan Authorized Service Facility within 30 calendar days of Service Bulletin compliance before the credit expiration dates shown below.

Domestic ..... September 14, 2015

International ..... September 14, 2015

Please contact a Cessna Caravan Authorized Service Facility for detailed information and arrange to have Cessna Service Bulletin CAB-32-01R1 accomplished on your airplane.

Access the QR code for the instructional video link that follows or use the URL address:



Select this link:

[http://textron.vo.llnwd.net/o25/CES/CustomerService/Caravan\\_208\\_CAB-32-01/Caravan\\_208\\_CAB-32-01.html](http://textron.vo.llnwd.net/o25/CES/CustomerService/Caravan_208_CAB-32-01/Caravan_208_CAB-32-01.html)

**NOTE:** As a convenience, service documents are now available online to all our customers through a simple, free-of-charge registration process. If you would like to sign up, please visit the "Customer Support Login" link at [www.Cessna.com](http://www.Cessna.com) to register.