

**DOCKET NO.: SA-519**  
**EXHIBIT NO. 8C**

**NATIONAL TRANSPORTATION SAFETY BOARD**  
**WASHINGTON, D.C.**

**POWERPLANTS GROUP CHAIRMAN'S FACTUAL REPORT**  
**JT8D-200 ENGINE CROSS SECTION SHOWING ALPHABETIC**  
**IDENTIFICATION OF CASE FLANGES**

**American Airlines flight 1420**  
**Little Rock, Arkansas**  
**June 1, 1999**

**DCA99MA060**

**FLANGES**

APPENDIX 2

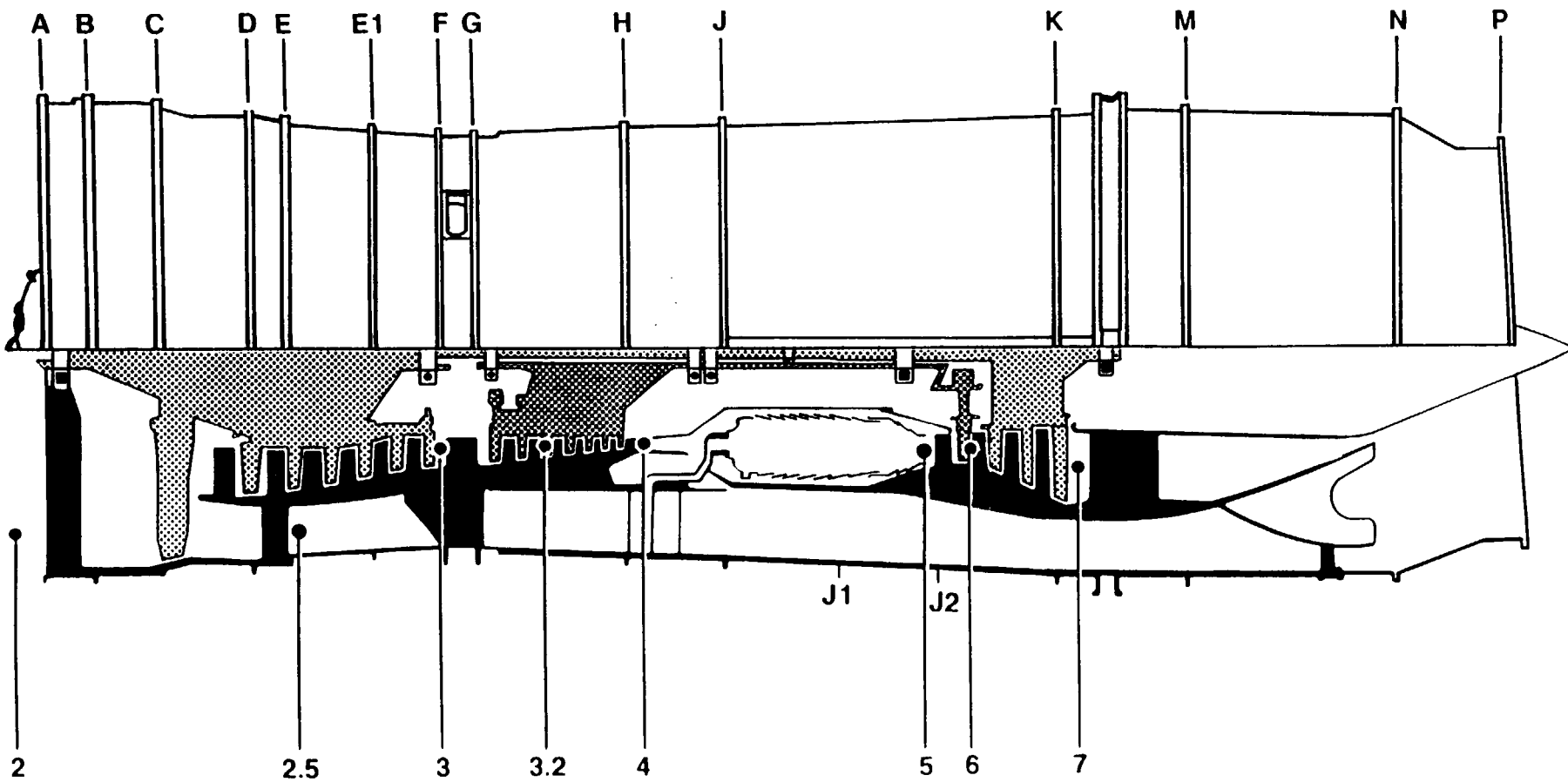

**STATIONS**

**ENGINE FLANGES AND STATIONS**