



NATIONAL TRANSPORTATION SAFETY BOARD

Office of Aviation Safety
Washington, D.C. 20594

October 30, 2014

Group Chairman's Factual Report

OPERATIONAL FACTORS

DCA13MA081

Table Of Contents

A.	ACCIDENT	4
B.	OPERATIONAL FACTORS GROUP.....	4
C.	SUMMARY.....	5
D.	DETAILS OF THE INVESTIGATION	5
E.	FACTUAL INFORMATION	6
1.0	History of Flight.....	6
2.0	Flight Crew Information	9
2.1	The Captain.....	10
2.1.1	The Captain’s Pilot Certification Record.....	11
2.1.2	The Captain’s Certificates and Ratings Held at Time of the Accident	11
2.1.3	The Captain’s Training and Proficiency Checks Completed	11
2.1.4	The Captain’s Flight Times.....	12
2.1.5	The Captain’s Schedule History.....	12
2.2	The First Officer	13
2.2.1	The First Officer Certification Record	13
2.2.2	The First Officer Certificates and Ratings Held at Time of the Accident.....	14
2.2.3	The First Officer Training and Proficiency Checks Completed	15
2.2.4	The First Officer’s Flight Times	15
2.2.5	The First Officer Schedule History	15
2.3	The Loadmaster	16
2.3.1	The Loadmaster’s Certification Record	16
2.3.2	The Loadmaster’s Training and Proficiency Checks Completed.....	17
2.3.3	Loadmaster Training	17
2.3.3.1	Loadmaster Initial Training.....	18
2.3.3.2	Loadmaster Recurrent Training	18
2.3.4	The Loadmaster’s Schedule History	19
3.0	Medical and Pathological Information.....	19
4.0	Aircraft Information.....	20
4.1	Aircraft Dimensions.....	21
5.0	Cargo Operations Manual	22
5.1	Load Responsibility	22
5.1.1	Load Planner	22
5.1.2	Load Supervisor/Loadmaster	23

5.1.3	Loader Operator	24
5.1.4	Forklift Operator or Pallet Transport Operator	24
5.1.5	Pilot in Command.....	25
6.0	Camp Bastion Loading	25
6.1	Pre-load planning	25
6.2	Pallet build-up and Shoring	27
6.3	Camp Bastion Pallet Build-up Demonstration Photos.....	32
6.3.1	12-Ton MATV Build-up Demonstration Photos	32
6.3.2	18-ton Cougar Build-up Demonstration Photos.....	34
6.4	Securing to the Main Deck	36
6.5	Cargo Operations Manual Guidance for Motor Vehicles.	39
6.6	Camp Bastion Loading Photos.....	40
6.6.1	Military Photos	40
6.6.2	National Air Cargo Photos	43
7.0	Weight and Balance	49
7.1	Weight and Balance Trim Sheet	51
8.0	Meteorological Information	52
9.0	Air Traffic Control.....	53
9.1	Bagram Tower Photos.....	54
10.0	Communications	55
11.0	Airport Information.....	55
11.1	Airport Communications	56
11.2	Charts	57
12.0	Organizational and Management Information	57
13.0	Relevant Procedures.....	61
13.1	Flight Crew Operations Manual (FCOM).....	61
13.2	B747-400 Flight Crew Procedures.....	62
13.2.1	Flight Crew Pre-flight of Cargo.....	62
13.2.2	Normal Procedures	64
13.2.3	Takeoff Briefing	65
13.2.4	Normal Takeoff Profile	65
13.2.5	Tactical Departures.....	66
13.2.6	Brake Temp Checklist	67
13.2.7	National Airlines Upset Recovery Guidance.....	67

13.2.7.1	Nose High Recovery	69
13.2.8	Boeing Upset Recovery Procedures	70
13.2.9	Upset Recovery Training Aid.....	70
13.3	Loadmaster Procedures	72
13.3.1	Loadmaster Duties	73
13.3.1.1	Preflight Duties	73
13.4	Main Deck Access	75
14.0	FAA Oversight.....	76
14.1	General.....	76
14.2	Loadmaster Oversight.....	78
14.3	Enroute and Ramp Inspections	79
14.4	Department of Defense Restrictions	81
14.5	Cargo Operations Oversight	82
14.6	Risk Management	84
14.7	Advisory Circular 120-85: Air Cargo Operations	85
14.8	FAA Guidance Post-Accident.....	85
F.	LIST OF ATTACHMENTS	85

A. ACCIDENT

Operator: National Airlines
Location: Bagram, Afghanistan
Date: April 29, 2013
Time: 1527 Local Time (1057Z)¹
Airplane: Boeing B747-428BCF² Registration Number: N949CA, Serial #25630

B. OPERATIONAL FACTORS GROUP

Captain David Lawrence - Chairman	Captain Jon Wiesinger ³
Senior Air Safety Investigator	B747-400 Captain
National Transportation Safety Board (NTSB)	National Airlines (NAL)
490 L'Enfant Plaza East S.W.	5955 TG Lee Blvd, #200
Washington, DC 20594	Orlando, FL 32822

¹ Bagram, Afghanistan local time was UTC (Universal Coordinated Time) + 4:30. Times listed in this Factual Report are UTC unless otherwise noted.

² Boeing Converter Freighter. The B747-400BCF is a former passenger configured airplane that has been converted to a cargo configuration.

³ National Airlines Captain Jose Rodriguez served on the Ops Group until September 19, 2013.

Captain Normand Bissonnette
B747-400 FSB/FOEB Chair
Federal Aviation Administration (FAA)
1601 Lind Avenue
Seattle, WA 98057

Lt. Colonel Mark Barker - Observer
AMC Liaison to FAA Standards
800 Independence Ave., SW Room 826
Washington, DC 20591

Captain David S. Goodwill
Boeing Flight Technical and Safety
P.O. Box 3707 MC 20-95
Seattle, WA 98124-2207

C. SUMMARY

On April 29, 2013, at about 1527 local time (1057Z), a Boeing 747-400, N949CA, operated as National Airlines flight 102, crashed shortly after takeoff from the Bagram Air Base (OAIX), Bagram, Afghanistan. All 7 crewmembers onboard were fatally injured and the airplane was destroyed from impact forces and post-crash fire. The 14 Code of Federal Regulations (CFR), Part 121 Supplemental cargo flight was destined for Dubai World Central - Al Maktoum International Airport (OMDW), Dubai, United Arab Emirates (UAE).⁴

D. DETAILS OF THE INVESTIGATION

On May 2, 2013, the NTSB Operations Group (Group) Chairman arrived in Bagram, Afghanistan. Other group members from the operator (National Airlines), the FAA, and the Department of Defense (DoD) assisted the Operations Group with the on-scene activities. Upon arrival, the group met the IIC and received an in-brief from the military's Incident Safety Board at Bagram regarding the accident site. The group then conducted an initial review of the wreckage and accident site. The group received weight and balance information, Operations Specifications (OpSpecs), National Airlines manuals, Boeing manuals, and additional documentation related to the accident flight.

On May 3, 2013, the Group assisted in the documentation of the wreckage site. Interviews with witnesses, ATC personnel, and National Air Cargo personnel were scheduled, and the group reviewed manuals and dispatch information related to the accident flight.

On May 4, 2013, the Group interviewed ATC controllers (Midwest Air Traffic Services), and toured/documented the ATC control tower at Bagram. In addition, the Group interviewed National Air Cargo loaders from Camp Bastion who loaded the accident airplane.

On May 5, 2013, the Group participated in a progress meeting and received a brief on CVR/FDR recorder data. The Group interviewed Flight Ops vehicle drivers who conducted the FOD

⁴ The investigation was originally led by the Afghanistan Ministry of Transportation and Civil Aviation (MoTCA), which appointed an IIC. The NTSB had assigned a U.S. Accredited Representative under the provisions of ICAO Annex 13, and was assisting the IIC (NTSB Accident DCA13RA081). In October 2014, the MoTCA delegated the investigation to the NTSB (NTSB Accident DCA13MA081).

(foreign object damage) sweeps following the accident airplane's departure, and National Air Cargo personnel based in Bagram. The Group also re-interviewed the Camp Bastion loaders.

On May 6, 2013, the Group participated in a pallet build-up demonstration with National Air Cargo loaders of a 12-ton MRAP. The Group also assisted in further documentation of the wreckage site.

On May 7, 2013, the Group participated in a pallet build demonstration with National Air Cargo ground crew of an 18-ton Cougar. The Group also interviewed witnesses to the accident, toured an exemplar National Airlines B747-400, and began working on field notes.

On May 8, 2013, the Group conducted field work at the accident site, and interviewed the National Air Cargo VP of Ground Operations.

On May 9, 2013, Group field notes were completed and signed by the participants to the Operations Group and delivered to the US Accredited Representative. The on-site field portion of the Operations Group investigation concluded on May 10, 2013.

From June 5-7, 2013, the Group conducted National Airlines interviews in Ypsilanti, Michigan. In addition, the Group conducted simulator work in the Kalitta B747-400 to review National Airlines upset recovery procedures.

From July 30, 2013 to August 2, 2013, the Group conducted interviews at the National Airlines offices in Orlando, Florida.

From August 23-24, 2013, the Group conducted FAA interviews of the Principal Operations Inspector (POI) and Principal Maintenance Inspector (PMI) at the FAA Flight Standards District Office (FSDO) in Belleville, Michigan. Additional documentation from National Airlines and the FAA were requested and reviewed during the following weeks.

E. FACTUAL INFORMATION

1.0 History of Flight

The accident flight was operated as part of the International Security Assistance Force (ISAF), outlined in United Nations Security Council resolution 1386 (adopted 2001). National Airlines operated under a multi-modal contract⁵ with US Transcom (Contract Number HTC711-12-D-R010) to transport military equipment.⁶ The accident flight was called ISAF 95AQ (I95AQ) for

⁵ Multi-modal Move: Being or involving more than one mode of transportation during a single journey, that permits the contractor to elect the most efficient type and/or mix of transportation methods (air, sea, rail, truck, barge, etc.) in order to meet a specified RDD (required delivery date). In a multimodal move, the prime contractor maintains responsibility and liability for the cargo during the entire movement from origin to final destination. (Source: Attachment 1, Contract #HTC711-12-D-R010 Performance Work Statement, Section 5.2. "Shippers will be responsible to load/unload ground conveyances at origin/final destination." Section 1.2.1).

⁶ According to the National Airlines Cargo Operations Manual, Chapter 8: AMC, page 8-1: "As a CRAF carrier, National Airlines accepts the policies and procedures of Air Mobility Command (AMC). These policies and procedures are found in Air Force Instruction (AFI) 24-203, AMCI24-201, AMCPAM24-2V1 and AMCPAM24-

air traffic control (ATC) identification purposes, and the civilian call sign was National Airlines flight 102 (NCR102). The flight had a crew of 7 (4 flight crew members, two mechanics, and one loadmaster).⁷

The original schedule was for the crew to operate flight NCR510 from Chateauroux, France (LFLX) to Camp Bastion, Afghanistan (OAZI), and then continue NCR510, departing Camp Bastion at 0235Z for a scheduled 2 hour and 35 minute flight to the Dubai World Center at Al Aktoum, UAE airport (OMDW). According to the National Airlines flight dispatcher for the flight, National Airlines could not obtain a Pakistan over-flight permit for the flight departing Camp Bastion to Dubai, and the dispatcher flight planned NCR102 to operate from Camp Bastion to Bagram, refuel, and continue NCR102 from Bagram to Dubai. This resulted in a total duty day of 25 hours and 4 minutes,⁸ with a planned total flight time of 14 hours and 11 minutes for the duty day.⁹ The accident crew began their duty day by operating NCR510 on April 28, 2013, departing Chateauroux, France at 1526Z and arriving into Camp Bastion, Afghanistan (OAZI) at 0029Z on April 29, 2013. According to National Air Cargo ground personnel, the inbound flight NCR510 to Camp Bastion was held for more than an hour in flight due to indirect fire (IDF) at the airport from the Taliban. The flight release for the Bagram to Dubai flight was emailed to the captain while the crew was in Camp Bastion.¹⁰

According to the load manifest, while in Camp Bastion, the airplane was loaded by National Air Cargo (NAC) ground personnel with 94,119kgs of cargo,¹¹ including 5 Mine Resistant Ambush Protected (MRAP) armored military vehicles that were loaded on the main deck of the airplane.¹² National Air Cargo was contracted by National Airlines to perform the pallet build up and loading of the cargo.¹³ Two of these vehicles weighed about 12 tons each, and the other three weighed about 18 tons each.¹⁴ According to National Airlines, the accident captain and first officer (FO) did not have prior experience carrying mine resistant armored vehicles,¹⁵ and it was the first time National Airlines had transported 18-ton military vehicles when they were loaded on the accident airplane in Camp Bastion.¹⁶

NCR102 departed Camp Bastion at 0745Z and arrived into Bagram at 0923Z. On arrival into Bagram, the crew experienced a brake overheat condition after landing on runway 03. The crew

2V5.”

⁷ See Attachment 6 – General Declaration.

⁸ According to the National Airlines General Operations Manual (GOM), Section 6.2, page 3-6, the flight crewmembers’ duty time began 90 minutes before scheduled departure time on an overwater or international leg, and ended 30 minutes after block arrival of the flight.

⁹ For additional information on augmented crews and duty time restrictions, see Section 2.0 Flight Crew Information of this Factual Report.

¹⁰ See Attachment 4 – Dispatch Release.

¹¹ See Attachment 21 – Weight and Balance.

¹² See Attachment 21 - Weight and Balance.

¹³ For an explanation of the relationship between National Airlines and National Air Cargo, see Section 12.0 Organizational and Management Information of this Factual Report.

¹⁴ For detailed information on the MRAP cargo load in Camp Bastion, see Section 6.0 “Camp Bastion Loading” of this Factual Report.

¹⁵ See Attachment 9 – Flight Crew Experience with MRAPs.

¹⁶ See Attachment 1 – Interview Summaries.

parked the airplane on the Foxtrot ramp¹⁷ and according to recorded information, the crew ran a checklist to address the brake temperature indications in the cockpit, and discussed the required cooling time of 1 to 1.5 hours.¹⁸ The crew did not take on any additional cargo in Bagram, and only took on fuel for the flight to Dubai. The airplane refueled to 48,000 kilograms of fuel.¹⁹ A National Air Cargo ground crew met the airplane during refueling, and only spoke with the loadmaster at the entrance of the main deck door. The flight release for the Bagram to Dubai leg had been emailed to the captain while the airplane was in Camp Bastion, so there was no paperwork exchanged, and the ground crew did not enter the airplane or cockpit and only spoke with the loadmaster.²⁰

According to recorded data, at about 0957 while the airplane was still on the ramp in Bagram, the captain was made aware of a broken strap found by one of the other crewmembers, and the cockpit crew had a discussion about a possible shift of the cargo load during landing in Bagram. There was additional discussion on re-securing the load prior to departure.

According to interviews with ATC personnel at Bagram, NCR102 taxied out normally for departure on runway 03 at Bagram at 1044:53Z. At 1045:32, NCR102 received and acknowledged the following ATC departure clearance to Dubai during its taxi to runway 03:²¹

Direct to SIBLO via diverse vectors.²² On departure fly runway heading until 3 DME, then turn left heading two one zero. Climb and maintain two eight zero, squawk zero four seven three. Departure frequency on two four point eight.

Weather for departure was good visibility, winds 020 degrees at 7 knots, scattered clouds at 4,000 feet with a broken ceiling at 8,000 feet.²³ NCR102 received and acknowledged their takeoff clearance at 1055:48Z. There were no other communications from NCR102 to ATC. According to interviews with ATC tower personnel, all communications with the accident crew were normal, and the takeoff roll appeared normal. The airplane rotated normally around the Charlie intersection of the runway, which according to ATC interviews, was a typical rotation point for the B747. According to preliminary recorded information, approximately 9 seconds after the crew called to rotate the airplane, the cockpit voice recorder (CVR) stopped recording,

¹⁷ See Attachment 28 – Bagram Airfield Diagram.

¹⁸ See Attachment 24 – B747 Brake Temp Checklist. According to recorded information, all brake temperatures returned to normal about an hour after the airplane was parked.

¹⁹ Post-accident fuel analysis was completed in Bagram, Afghanistan. See Attachment 21 - Weight and Balance.

²⁰ Flight plans at National Airlines were automated and filed via NavTech. The computer flight planning system combines the Flight Release and Computer Flight Plan into a single document. Required weather reports and NOTAMs are included with the Flight Release. Source: National Airlines General Operations Manual, Section 4.3.2.

²¹ See Attachment 5 – ATC.

²² Diverse Vector Area/s (DVAs) may be established at the request of the ATM and coordinated jointly with the appropriate Service Area OSG and Mission Support Services, Terminal Procedures and Charting Group for candidate airports within the facility's area of jurisdiction. DVAs should be considered when an obstacle(s) penetrates the airport's diverse departure obstacle clearance surface (OCS). The OCS is a 40:1 surface and is intended to protect the minimum climb gradient. For additional information, see FAAO JO 7210.3, Para 3–9–5, Establishing Diverse Vector Area/s (DVA).

²³ This was the recorded weather at 1055Z, about 2 minutes prior to the accident. For additional information, see Section 8.0 Meteorological Information of this factual report.

and approximately 3 seconds later the flight data recorder (FDR) stopped recording. According to witnesses and video evidence, after becoming airborne, the airplane continued to pitch up until it appeared to stall, turn to the right, then descended to impact with the ground just beyond the departure end of runway 03 and to the right.

2.0 Flight Crew Information

The accident crew consisted of two captains, two first officers, two mechanics and one loadmaster. The two additional pilots (captain and first officer) were considered augmented flight crew members so the flight could be operated under the provisions of 14 CFR 121.523.²⁴ The National Airlines General Operating Manual (dated September 13, 2012), Section 6.3.6 “Heavy (Double) Crew (747 Aircraft)” stated, in part:

The 747 aircraft can also be flown with a Heavy (sometimes referred to as a Double) Crew due to its rest facility. This crew consists of 4 pilots. As highlighted above under augmented crew (747 aircraft), this type of crew can have a duty day of 30 hours.

14 CFR 121.523 stated, in part:

(b) Each certificate holder conducting supplemental operations shall schedule its flight hours to provide adequate rest periods on the ground for each airman who is away from his principal operations base. It shall also provide adequate sleeping quarters on the airplane whenever an airman is scheduled to be aloft as a flight crewmember for more than 12 hours during any 24 consecutive hours.

(c) No certificate holder conducting supplemental operations may schedule any flight crewmember to be on continuous duty for more than 30 hours. Such a crewmember is considered to be on continuous duty from the time he reports for duty until the time he is released from duty for a rest period of at least 10 hours on the ground. If a flight crewmember is on continuous duty for more than 24 hours (whether scheduled or not) duty any scheduled duty period, he must be given at least 16 hours for rest on the ground after completing the last flight scheduled for that scheduled duty period before being assigned any further flight duty.

A flight crew member assigned to a crew of three or more may not be scheduled to be on continuous duty for more than 30 hours. Further, according to the National Airlines General Operating Manual (GOM), when any flight crew member was scheduled to be aloft as a flight crewmember for more than 12 hours in any consecutive 24 hours, adequate crew rest facilities shall be provided aboard the aircraft.²⁵ The accident airplane had approved crew rest facilities.²⁶

²⁴ An unaugmented flight contains the minimum number of flightcrew members necessary to safely pilot an aircraft. An augmented flight contains additional flightcrew members and at least one onboard rest facility, which allows flightcrew members to work in shifts and sleep during the flight.

²⁵ According to FAA Order 8900.1 CHG 304, Volume 3, Chapter 58, Section 3: “The criteria for adequate sleeping quarters may be found in Advisory Circular (AC) 121-31, Flight Crew Sleeping Quarters and Rest Facilities. Additionally, the Federal Aviation Administration (FAA) has issued legal interpretations defining the meaning of adequate sleeping quarters (see letter to Mr. Wells dated 9/22/03) in which the FAA stated, “Generally, an adequate rest facility means a bunk or berth.” However, the industry has loosely interpreted the meaning of a rest facility, which has resulted in a wide variation of sleeping quarters. NOTE: It is important to note that the purpose of a rest

Due to the extensive damage of the airplane, it could not be determined if either augmented flight crewmember occupied any of the cockpit jumpseats at the time of the accident. According to the National Airlines FCOM “Normal Procedures”, page NP.11.3, for augmented crews, the Captain shall assign Relief Officer (R/O) duties. As a minimum, these duties shall include:

- *Occupying an observer’s seat prior to the BEFORE START checklist until after the completion of the AFTER TAKEOFF checklist.*
- *Occupying an observer’s seat prior to the Approach Briefing and DESCENT/APPROACH checklist through completion of the SHUTDOWN checklist. PF and PM duties may change during a flight. For example, the captain could be the PF during taxi but be the PM during takeoff through landing.*

The accident captain and first officer were flying multi-day pairings that began on April 18, 2013 for the captain and on April 17, 2013 for the first officer. Both accident pilots began flying together in Ramstein Air Base (ETAR) on April 20, 2013 to McGuire Air Force Base (KWRI), and were paired together for the remaining days until the accident.

2.1 The Captain

The accident captain was 34 years old and resided in Southgate, Michigan. His date of hire with National Airlines was June 3, 2004. He upgraded on the B747-400 on June 22, 2012, having previously served as a captain on the DC-8. Prior to his employment with National Airlines, the accident captain was a flight instructor at Jackson Community College in Jackson, Michigan from May 2002 to April 2004. He graduated from Eastern Michigan University in Ypsilanti, Michigan in December 2001 with a Bachelor of Science degree in Aviation Management.

The National Airlines check airman who last provided the accident captain his B747-400 proficiency check said the accident captain was “a well prepared student” and dedicated.²⁷ The check airman also said the captain was “excellent” in his training, and “was a pleasure to be an instructor for” and “pretty sharp.” One National Airlines first officer stated he remembered the accident captain as being very knowledgeable and having great CRM (crew resource management) procedures.

The captain was current and qualified under National Airlines and FAA requirements. A review of FAA PTRS²⁸ records found no prior accident, incident or enforcement actions. A search of

facility is to provide a suitable area for flightcrew members to rest during long-haul operations while operating in an augmented crew configuration.”

²⁶ Source: National Airlines GOM, Section 6.5.3 “Three or More Pilots and an Additional Airman (as required).”

²⁷ See Attachment 1 – Interview Summaries.

²⁸ The Program Tracking and Reporting Subsystem (PTRS) is a comprehensive information management and analysis system used in many Flight Standards Service (AFS) job functions. It provides the means for the collection, storage, retrieval, and analysis of data resulting from the many different job functions performed by Aviation Safety Inspectors (ASIs) in the field, the regions, and headquarters. This system provides managers and inspectors with current data on airmen, air agencies, air operators, and many other facets of the air transportation system. Source: FAA.

records at the National Driver Registry (NDR) found no history of driver's license revocation or suspension.

2.1.1 The Captain's Pilot Certification Record

FAA records of the accident captain indicated the following:

Private Pilot – Airplane Single Engine Land certificate issued May 4, 1999.

Commercial Pilot – Airplane Single Engine Land (Not valid for carriage of passengers for hire in airplanes on cross-country flights of more than 50NM, or at night) certificate issued May 14, 2001.

Commercial Pilot – Airplane Single Land, Instrument Airplane certificate issued August 14, 2001.

Flight Instructor –Airplane - Single Engine (expires January 31, 2004) certificate issued January 30, 2002.

Flight Instructor –Airplane - Single Engine, Instrument Airplane (expires December 31, 2005) certificate issued December 19, 2003.

Renewed December 8, 2005; December 18, 2007; December 29, 2009; November 30, 2011.

Commercial Pilot – Airplane Single and Multiengine, Land Instrument Airplane certificate issued January 9, 2004.

Airline Transport Pilot – Airplane Multi-Engine Land, DC-8 (DC-8 Circ. Apch. VMC Only, ATP Circ. Apch. VMC Only), Commercial Privileges Airplane Single Engine Land certificate issued July 21, 2006.

Airline Transport Pilot – Airplane Multi-Engine Land, B-747-4 DC-8 (DC-8 B747 Circ. Apch. VMC Only, ATP Circ. Apch. VMC Only, English Proficient), Commercial Privileges Airplane Single Engine Land certificate issued June 22, 2012.

2.1.2 The Captain's Certificates and Ratings Held at Time of the Accident

AIRLINE TRANSPORT PILOT (issued June 22, 2012)

AIRPLANE MULTIENGINE LAND, B747-4 DC-8 (DC-8 B747 CIRC. APCH. VMC ONLY, ATP CIRC. APCH. VMC ONLY, ENGLISH PROFICIENT), COMMERCIAL PRIVILEGES AIRPLANE SINGLE ENGINE LAND

FLIGHT INSTRUCTOR (issued November 30, 2011)

AIRPLANE SINGLE ENGINE INSTRUMENT AIRPLANE

MEDICAL CERTIFICATE FIRST CLASS (issued May 24, 2012)

LIMITATIONS: MUST WEAR CORRECTIVE LENSES.

2.1.3 The Captain's Training and Proficiency Checks Completed²⁹

Date of Hire	June 3, 2004
Date First Upgrade to Captain Position (DC-8)	July 7, 2006

²⁹ Source: National Airline. See Attachment 3 – Crew Training Records.

Date Transitioned to Captain on B747-400	June 22, 2012
Date of Initial Type Rating on This Airplane	June 22, 2012
Date of Most Recent Proficiency Check	June 22, 2012 ³⁰
Date of Most Recent Proficiency Training	November 19, 2012
Date of Most Recent PIC Line Check	August 10, 2012

2.1.4 The Captain's Flight Times³¹

The captain's flight times provided to the NTSB:

Total pilot flying time	6,000
Total Pilot-In-Command (PIC) time	4,700
Total B747-400 time	439
Total B747-400 PIC time	439
Total flying time last 24 hours	14
Total flying time last 30 days	74
Total flying time last 90 days	162
Total flying time last 12 months	561 ³²

2.1.5 The Captain's Schedule History³³

Prior to departing on his sequence of flying, the accident captain was scheduled off days from April 8, 2013 to April 17, 2013. On April 18, 2013, he travelled from his home base in Detroit, Michigan, to Ramstein Air Base, Germany where he had 28 hours and 15 minutes off duty before his next flight assignment. On April 20, 2013 he operated as part of a "heavy" crew (2 captains and 2 first officers) from Ramstien Air Base, Germany to McGuire Air Force Base, and then deadheaded on the aircraft to Rockford, Illinois for a total duty day of 18 hours 58 minutes and a block³⁴ time of 8 hours 29 minutes. In Rockford, Illinois, he was off duty for 31 hours and 40 minutes.

On April 22, 2013 he was part of a "heavy" crew that positioned the aircraft from Rockford, Illinois to Kunsan Air Base, Korea. The total duty was 16 hours and 1 minute with a total block of 14 hours 08 minutes. At Kunsan Air Base, he was off duty for a total of 20 hours 58 minutes.

On April 23, 2013, he was part of a "heavy" crew that operated 3 segments, originating at Kunsan Air Base to Iwakuni, Japan with a technical stop in Anchorage, AK and then to the final

³⁰ The accident captain was issued an additional proficiency check on October 18, 2012 to extend his consolidation of learning.

³¹ Source: National Airlines.

³² According to National Airlines, the accident captain completed 12 OAIX (Bagram Airfield) operations within the preceding 12 calendar months.

³³ Information provided to the NTSB by National Airlines. For additional information, see Attachment 2 - Crew Information.

³⁴ According to the National Airlines General Operations Manual, page 3-5: "Part 121 defines flight time as "block to block" time (while aircraft times are normally recorded from takeoff to landing)."

destination of Hill Air Base, Utah (KHIF). The total duty for the 3 segments was 18 hours 45 minutes with a total block time of 12 hours 43 minutes. He remained at Hill Air Base, Utah for 73 hours 21 minutes before his next flight assignment.

On April 27, 2013, he operated as part of an augmented crew (two captains and one first officer) positioning the accident airplane from Hill Air Base, Utah to Chateauroux, France. The total duty was 12 hours 8 minutes with a total block time of 9 hours 32 minutes. At Chateauroux, France, the accident captain was off duty for 12 hours 18 minutes before his next assignment.

On April 28, 2013, he was scheduled to operate as part of a “heavy“ crew of two captains and two FOs flying three segments with a total duty of 25 hours and 4 minutes and a total block time of 14 hours 11 minutes. The revised segments would have been from Chateauroux, France to Camp Bastion Airfield, Afghanistan continuing to Bagram, Afghanistan then the final leg to Al Maktoum, UAE. At the time of the accident, the captain and flight crew had completed the first two segments for a total block time of 10 hours 41 minutes. He had checked in at 1400Z on April 28, 2013 and had been on duty for approximately 21 hours at the time of the accident.

2.2 The First Officer

The accident first officer was 33 years old and resided in Three Rivers, Michigan. His date of hire with National Airlines was February 23, 2009. He transitioned to B747-400 first officer on July 20, 2012, having previously served as a DC-8 first officer. Prior to his employment with National Airlines, the accident first officer was an instruments and flight controls craftsman technician on the B-1B bomber for the United States Air Force at Dyess Air Force Base in Abilene, Texas from January 2002 to March 2008. He graduated from the Community College of the Air Force in December 2007 with an Associates of Science Degree in Aviation Maintenance Technology.

The National Airlines B747-400 check airman who provided initial B747-400 simulator training for the accident first officer said the accident first officer’s simulator performance was good for a pilot new to the airplane, coming off the DC-8, and he was “very well prepared.”³⁵ A B747-400 captain for National Airlines who flew with the accident first officer said the accident first officer’s pilot monitoring skills were great, and he was very professional. Another captain said the accident first officer had “good flying skills for his low pilot time in general.”³⁶

The first officer was current and qualified under National Airlines and FAA requirements. A review of FAA PTRS records found no prior accident, incident or enforcement actions. A search of records at the National Driver Registry (NDR) found no history of driver’s license revocation or suspension.

2.2.1 The First Officer Certification Record

FAA records of the accident first officer indicated the following:

³⁵ See Attachment 1 – Interview Summaries.

³⁶ See Attachment 1 – Interview Summaries.

Private Pilot – Airplane Single Engine Land certificate issued May 26, 2008.
Private Pilot – Airplane Single and Multiengine Land certificate issued June 25, 2008.
Private Pilot – Airplane Single and Multiengine Land Instrument Airplane certificate issued August 3, 2008.
Commercial Pilot – Airplane Multiengine Land, Private Pilot privileges Airplane Single Engine Land Instrument Airplane certificate issued September 19, 2008.
Ground Instructor Advanced Instrument certificate issued September 24, 2008.
Flight Instructor – Airplane Multiengine (expires October 31, 2010) certificate issued October 1, 2008.
Flight Instructor – Instrument Airplane Multiengine (expires October 31, 2010) certificate issued October 4, 2008.
Commercial Pilot – Airplane Single and Multiengine Land, Instrument Airplane certificate issued October 8, 2008.
Flight Instructor – Instrument Airplane Single and Multiengine (expires October 31, 2010) certificate issued October 10, 2008.
Renewed October 22, 2010; September 12, 2012.
Mechanic Airframe, Powerplant certificate issued February 14, 2009.
Flight Engineer Turbo-jet Powered certificate issued April 17, 2009.
Commercial Pilot – Airplane Single and Multiengine Land DC-8 (DC-8 SIC Privileges Only), English Proficient certificate issued March 24, 2011.
Commercial Pilot – Airplane Single and Multiengine Land, Instrument DC-8 (DC-8 SIC Privileges Only, DC-8 Circ Apch – VMC Only), English Proficient certificate issued July 7, 2011.
Commercial Pilot – Airplane Single and Multiengine Land, Instrument Airplane, B747-400 DC-8 (B747-400, DC-8 SIC Privileges Only; B747-400, DC-8 Circ Apch – VMC Only), English Proficient certificate issued August 8, 2012.

2.2.2 The First Officer Certificates and Ratings Held at Time of the Accident

COMMERCIAL PILOT (issued August 8, 2012)
AIRPLANE SINGLE AND MULTI-ENGINE LAND AIRPLANE,
B-747-400, DC-8 SIC PRIVILEGES ONLY; B747-400, DC-8 CIRC APCH –
VMC ONLY; ENGLISH PROFICIENT

FLIGHT INSTRUCTOR (issued September 12, 2012)
INSTRUMENT AIRPLANE SINGLE AND MULTI-ENGINE

MECHANIC AIRFRAME, POWERPLANT (issued February 14, 2009)

FLIGHT ENGINEER TURBO-JET POWERED (issued April 17, 2009)

MEDICAL CERTIFICATE FIRST CLASS (issued March 23, 2013)
LIMITATIONS: NONE.

2.2.3 The First Officer Training and Proficiency Checks Completed³⁷

Date of Hire	February 23, 2009
Date Transitioned on B747-400	July 20, 2012
Date of Most Recent Proficiency Check	October 10, 2012
Date of Most Recent Line Check	April 13, 2013

2.2.4 The First Officer's Flight Times³⁸

The accident first officer times provided to the NTSB:

Total pilot flying time	1100 ³⁹
Total Flight Engineer time	720
Total Pilot-In-Command (PIC) time	451
Total B747-400 time (SIC)	209
Total flying time last 24 hours	14
Total flying time last 30 days	71
Total flying time last 90 days	140
Total flying time last 12 months	219

2.2.5 The First Officer Schedule History⁴⁰

Prior to departing on his sequence of flying, the accident FO was at his Detroit, Michigan home-base on 5 days of leave that he had requested from April 3, 2013 to April 7, 2013 followed by 8 assigned days off. On April 16, 2013, he travelled to Fresno, CA where he had 33 hours 11 minutes off duty before his next flight assignment. On April 18, 2013, he operated as part of a "heavy" crew (two captains and two FO's) from Fresno, CA to McGuire Air Force Base, and then continued to Ramstein Air Base, Germany for a total duty of 19 hours 28 minutes and block time of 11 hours 57 minutes. He was off duty for 31 hours 02 minutes before his next flight assignment.

On April 20, 2013, he operated as part of a "heavy" crew from Ramstien Air Base, Germany to McGuire Air Force Base, and then deadheaded on the airplane to Rockford, Illinois for a total duty day of 18 hours 58 minutes and a block time of 8 hours 29 minutes. At Rockford, Illinois, he was off duty for 31 hours and 40 minutes.

³⁷ Source: National Airlines.

³⁸ Source: National Airlines. See Attachment 3 – Crew Training Records.

³⁹ Total pilot time and flight engineer time are estimates and based upon the most recent resume on file at National Airlines and flight times provided by National Airlines.

⁴⁰ Information provided to the NTSB by National Airlines. For additional information, see Attachment 2 - Crew Information.

On April 22, 2013, he was part of a “heavy” crew that positioned the airplane from Rockford, Illinois to Kunsan Air Base, Korea. The total duty was 16 hours 01 minute with a total block of 14 hours 08 minutes. At Kunsan Air Base he was off duty for a total of 20 hours 58 minutes.

On April 23, 2013, he was part of a “heavy” crew that operated three segments originating at Kunsan Air Base to Iwakuni, Japan with a technical stop in Anchorage, Alaska, and then to the final destination Hill Air Base, Utah. The total duty for the 3 segments was 18 hours 45 minutes with a total block time of 12 hours 43 minutes.

The accident FO remained at Hill Air Base, Utah for 73 hours 21 minutes before his next flight assignment. During that period, he was assigned a 24 hour break on April 25, 2013, and an additional 10 hour rest period from 1430z on April 26, 2013 to 0030z on April 27, 2013.

On April 27, 2013, he operated as part of an augmented crew positioning the airplane from Hill Air Base, Utah to Chateauroux, France. The total duty was 12 hours 08 minutes with a total block time of 9 hours 32 minutes. At Chateauroux, France he was off duty for 12 hours 18 minutes before his next assignment.

On April 28, 2013, he was scheduled to operate a revised schedule as part of a “heavy” crew flying three segments with a total duty of 25 hours 04 minutes and a total block of 14 hours 11 minutes. The revised segments would have been from Chateauroux, France to Camp Bastion Airfield, Afghanistan continuing to Bagram, Afghanistan then the final leg to Al Maktoum, UAE. At the time of the accident they had completed the first two segments for a total block time of 10 hours 41 minutes. He had checked in at 1400z on April 28, 2013 and had been on duty for approximately 21 hours at the time of the accident.

2.3 The Loadmaster

The accident loadmaster was 46 years old and resided in Ypsilanti, Michigan. His date of hire with National Airlines was November 22, 2010. Prior to his employment with National Airlines, the accident loadmaster was a ground handling supervisor/trainer for CP Deliveries from 2004 until November 2010. According to his resume on file with National Airlines, from 2000 to 2004 he also was a “journeyman carpenter.”

2.3.1 The Loadmaster’s Certification Record

According to the FAA, the position of “loadmaster” was not defined in the Code of Federal Regulations (CFRs), and it was not a certificated position. There were no duty time or rest requirements for loadmasters, and there were no training requirements for loadmasters contained in 14 CFR 121. The FAA did not track the position of “loadmaster” or similar duty position.⁴¹

⁴¹ See Attachment 8 – FAA Responses.

2.3.2 The Loadmaster's Training and Proficiency Checks Completed⁴²

According to company records, the accident loadmaster attended loadmaster initial training at National Airlines from December 6, 2010 to December 14, 2010. He attended a three day loadmaster recurrent training between December 1 and December 3, 2011. Between January 5 and January 9, 2012, the accident loadmaster attended B747-400 training that included a review of a Telair cargo loading DVD, B747-400 aircraft familiarization, and B747-400 weight and balance training. In addition, he attended a one day training session on a computerized B747-400 weight and balance system on May 8, 2012.

The accident loadmaster received a line evaluation on the accident airplane on December 16, 2012 from Riga, Latvia to McGuire Air Force Base (KWRI) to Ramstein Air Force Base (ETAR). This evaluation included an evaluation of tiedown restraint criteria and calculations, shoring (load spreading) criteria and computations, and cargo conveyance/restraint systems operation. His overall performance was graded as satisfactory. According to the National Airlines Chief Loadmaster, an evaluation form was used for line evaluations, and the 1996 evaluation form the National Airlines Chief Loadmaster first created "had been altered over time,"⁴³ and National Airlines was in the process of implementing that form formally into their manuals (Cargo Operations Manual) since the accident.⁴⁴ According to the National Airlines Chief Loadmaster, the FAA had not yet signed off on the change.

2.3.3 Loadmaster Training

Loadmaster training requirements were not defined in the CFRs. Specifics on loadmaster training were not included in the National Airlines General Operations Manual, Flight Operations Training Manual or Weight and Balance Manual, nor was it required. The National Airlines Cargo Operations Manual listed general training modules of learning.⁴⁵ Training, evaluations, scheduling, policies and procedures for loadmasters at National Airlines were the responsibility of the Chief Loadmaster. The National Airlines Chief Loadmaster had held that position since he was hired by the airline in October 2010, and he was responsible for about 13 loadmasters and 3 "check loadmasters." The National Airlines Chief Loadmaster told NTSB Staff he did not have any FAA certificates or licenses.⁴⁶ He stated he wrote the policies, procedures, training and evaluations for loadmasters at the airline.

Loadmasters and cargo loaders from National Air Cargo, responsible for pallet build up and loading of the airplanes, did not train together. Pilots and loadmasters also did not train together. While pilots received CRM training, the National Airlines Director of Safety stated he did not know if loadmasters were trained in CRM.

⁴² See Attachment 3 – Crew Training Records.

⁴³ See Attachment 1 – Interview Summaries.

⁴⁴ See Attachment 1 – Interview Summaries.

⁴⁵ For additional information, see Attachment 12 – Loadmaster Training.

⁴⁶ See Attachment 1 – Interview Summaries.

National Airlines provided the NTSB with separate outlines for initial and recurrent loadmaster training as part of the accident loadmaster's training file. Training times listed below were derived from the accident loadmaster's training file.⁴⁷

2.3.3.1 Loadmaster Initial Training⁴⁸

According to National Airlines, the loadmaster initial training syllabus was a 68 hour course that consisted of the following subjects:

Dangerous Goods training	24 hours
Departmental Policies and Procedures	4 hours
Flight and Cargo Documentation	3 hours
Ground Operations	8 hours
757 Emergency Equipment Training	2 hours
757 Door Training	
757 Ditching	
Ground Security Coordinator Training	4 hours
Passenger Operations security (2 hours)	
Cargo operations security (2 hours)	
Aircraft Familiarization and Weight and Balance	
DC-8	2 hours
B757	4 hours
B747-400 (includes Telair DVD)	12 hours
CRM Training	2 hours
HR Orientation	3 hours
Total Time	68 hours

2.3.3.2 Loadmaster Recurrent Training⁴⁹

According to National Airlines, the loadmaster recurrent training syllabus was a 24 hour course that consisted of the following subjects:

Dangerous Goods training	8 hours
Departmental Policies and Procedures	1 hour
Flight and Cargo Documentation	1 hour
Ground Operations	2 hours
757 Emergency Equipment Training	2 hours
757 Door Training	
757 Ditching	
Ground Security Coordinator Training	4 hours
Passenger Operations security	
Cargo operations security	
Aircraft Familiarization and Weight and Balance	

⁴⁷ For additional information, see Attachment 3 - Crew Training Records.

⁴⁸ See Attachment 3 – Crew Training Records.

⁴⁹ See Attachment 3 – Crew Training Records.

DC-8	1 hour
B757	1 hour
B747-400 (includes Telair DVD)	2 hours
CRM Training	2 hours
Fundamentals of Instructing (check LMs)	1 hour*
Total Time	24/25 hours

2.3.4 The Loadmaster’s Schedule History⁵⁰

On April 26, 2013, the accident loadmaster travelled from Detroit, Michigan (DTW) home base to Hill Air Base, Utah. Prior to travel he had been on days off in DTW.

On April 27, 2013 the loadmaster showed at the aircraft at 1610z, and operated a positioning flight from Hill Air Base, Utah to Chateauroux, France. The total duty was 12 hours 08 minutes with a total block time of 9 hours 32 minutes. At Chateauroux, France he was off duty for 12 hours 18 minutes before his next assignment. On the day of the accident, the loadmaster was scheduled to operate the same flight segments as the flight crew, operating from Chateauroux, France to Camp Bastion Airfield, continuing to Bagram, Afghanistan and then the final leg to Al Maktoum, UAE. At the time of the accident he had completed the first two segments for a total block time of 10 hours 41 minutes. He had checked in at 1400z on April 28, 2013 and was at approximately 21 hours of duty at the time of the accident.

3.0 Medical and Pathological Information

Autopsies were performed by the Armed Forces Medical Examiner, per 10 U.S. Code 1471. The accident captain, first officer, loadmaster, and remaining crew were all fatally injured, and the causes of death was listed as “multiple injuries,” with the manner of death listed as “accident.” Toxicology results for the accident captain, first officer and loadmaster were all negative.

⁵⁰ Information provided to the NTSB by National Airlines. For additional information, see Attachment 2 - Crew Information.

4.0 Aircraft Information



Photo 1: Accident Airplane (N949CA)

The accident airplane (Serial number 25630, Registration N949CA) was a Boeing B747-428 BCF (Boeing Converted Freighter) manufactured February 10, 1993 and registered to Wells Fargo Bank Northwest. The airplane was certified in the Transport Category per 14 CFR Part 25 and Part 36. According to the National Airlines B747-400 FCOM “Airplane General”⁵¹ the airplane was approved for the following kinds of flight and operation, both day and night, when the required equipment was installed and approved in accordance with the applicable Federal Aviation Regulations:

- Visual (VFR)
- Instrument (IFR)
- Icing Conditions
- Extended Overwater

According to maintenance records for the accident aircraft (N949CA, serial #25630), the one deferred maintenance item on the accident flight was for a hydraulic pump removed from the fly away kit (FAK).⁵²

⁵¹ Source: National Airlines B747-400 FCOM, page L.10.1

⁵² The National Airlines B747 Minimum Equipment List (MEL), page 24 stated the following: “Fly Away Kit (FAK) – Sometimes called Spare Parts Kit (SPK), a Fly Away Kit is a National Airlines kit of tools, supplies and spare parts placed on the aircraft. The content of the FAK is aircraft specific and is determined by the Director of Maintenance. The FAK will have a specific location and contents in keeping with weight and balance control.”

4.1 Aircraft Dimensions

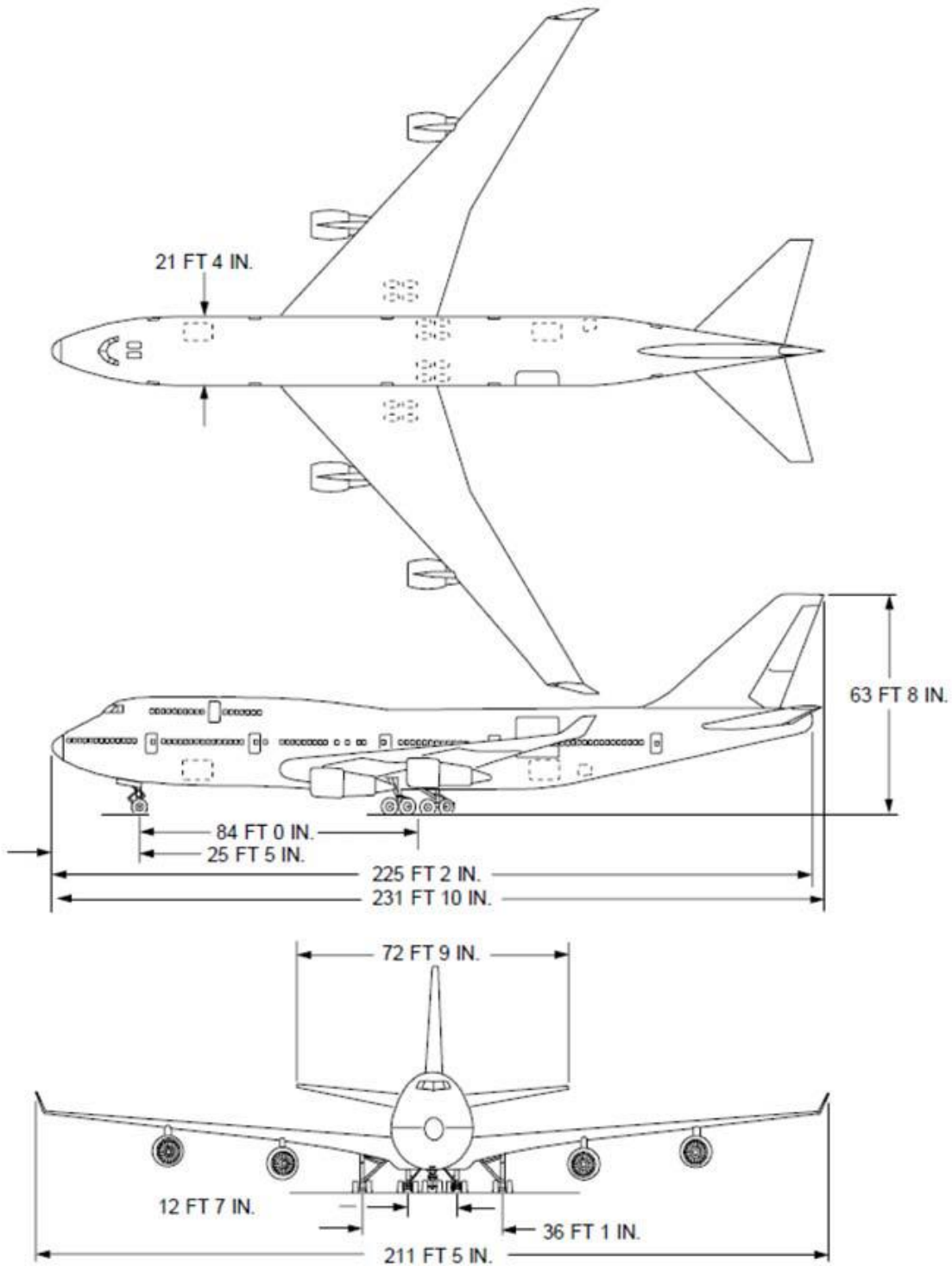

Figure 1: B747-400 General Arrangement and Primary Dimensions.⁵³

⁵³ Source: National Airlines Cargo Operations Manual, page 9-8.

5.0 Cargo Operations Manual

National Airlines company policies and procedures regarding cargo operations were incorporated in the National Airlines Cargo Operations Manual (dated September 25, 2012). The National Airlines Cargo Operations Manual, Section 1.2 “Guiding Authorities”, page stated in part:

This Manual presents the Company Operations and System Control policies and procedures for Carriage of Cargo Operations. These policies and procedures supplement the General Operations Manual and General Maintenance Manual and were developed in accordance with Advisory Circular AC 120-85, IATA Dangerous Goods Regulations, National Airlines Hazardous Materials Manual, Flight Standards Information Management System 8900.1, ATOS Data Collection Tool SAI 1.3.25 Cargo Handling Equipment, Systems and Appliances (AW), ATOS Data Collection Tool SAI 3.1.8 Carriage of Cargo (OP) and all applicable Federal Aviation Regulations (14 CFRs). The procedures and processes contained within this chapter are used to ensure that no aircraft is allowed to take off unless all components of the Cargo Operations program have been executed.

Checklists and procedures used by the National Airlines loadmasters were found in the Cargo Operations Manual. According to the National Airlines Chief Loadmaster, the information contained in the manual was to “ensure the loadmaster would make a safe and informed decision.”⁵⁴ Procedures for loading supervisors were also contained in the manual.

According to the FAA and National Airlines, the Cargo Operations Manual was an FAA accepted manual, not an FAA approved manual.⁵⁵ According to the National Airline POI, accepted manuals generally involved policies and procedures not specific to the OpSpecs.⁵⁶

5.1 Load Responsibility

5.1.1 Load Planner

The National Airlines Weight and Balance Manual, Chapter 2 “Loading Information” page 2-3, stated in part:

The Preparer/Agent completes the following on the form:

- *Date*
- *Aircraft*
- *Flight Number*
- *Gross Weight*
- **Pieces*
- **Net Weight*
- *Destination*
- **Customer*

⁵⁴ See Attachment 1 – Interview Summaries.

⁵⁵ The approval and acceptance process for manuals and checklists were defined in FAA guidance 8900.1, Volume 3, Sections 2 “Approval and Acceptance of Manuals and Checklists”, paragraph 3-3151.

⁵⁶ See Attachment 1 – Interview Summaries.

- *ULD Number*

**Denotes completion of this item may be done after loading as this pertains to down line destinations and tracking. In completing the form the planner will ensure the aircraft will operate within approved limits of the center of gravity. After completion of this form the Agent will sign the form and brief the Flight and Ramp Operations Manager Down Line Destinations or Loadmaster with any special loading requirements.*

National Airlines used National Air Cargo in Dubai, UAE (Dubai World Central) for load planning, cargo/pallet build up, and aircraft loading of the National Airlines B747-400.⁵⁷ According to the National Air Cargo Vice President of Ground Ops Middle East, there were four load planners in Dubai, and two were “approved” by National Airlines, and the load planners were certified by ICAO standards.

5.1.2 Load Supervisor/Loadmaster

The National Airlines Weight and Balance Manual, Chapter 2 “Loading Information” page 2-1 stated in part:

The National Airlines Load Supervisor (Loadmaster) or qualified representative is responsible for the acceptance of all cargo planeside, and that all ULDs and pallets are properly identified and tagged in accordance with the COM [Cargo Operations Manual] requirements. The load supervisor is also responsible for verifying the aircraft is loaded and cargo weights checked for accuracy in accordance with the loading manifest provided by the National Airlines OCC. This verification is essential to ensure weight and balance calculations previously performed by National Airlines OCC are valid.

In addition, the National Airlines Cargo Operations Manual, Section 1.8.3 “Load Supervisor”, page 1-7, stated in part:

For the purpose of this manual, the title Load Supervisor can be interchanged with Plane Side Representative, Experienced Cargo Handling Personnel, Loadmaster, Mechanic or Flight Engineer. The Loading Supervisor is responsible for:

- *Reviewing the location of any missing restraint (Beartrap, side lock etc.) and advising maintenance for any corrections.*
- *Confirm load and proper ULD contour.*
- *Confirm Proper tie down.*
- *Reject any damaged pallets and nets or correct to meet Company requirements and standards.*
- *Pallet, container and nets should be examined by the Loading Supervisor for gouges, depressions, delaminated panels, cracked edge rails, bowing, and missing corners and rivets to meet Company requirements and standards.*
- *Confirm Number*
- *Tail Stand and tail post are being properly used.*

⁵⁷ For additional information on National Airlines and National Air Cargo, see Section 12.0 Organizational and Management Information of this Factual Report.

- *Visually inspect the Aircraft for possible damage caused by ground support equipment*
- *Signs appropriate Load Planning Sheet after loading completed verifying that the aircraft was loaded according to the Load Planning Sheet and I/A/W Company loading requirements, and that all locks, in the pallet positions, are properly installed and in the pallet locked position. The original copy of form will be returned to the Cargo Operations Agent for the Company principal base of operation or down line destination, as applicable, file and a signed copy will be given to the crew. The PIC of the flight must carry in the aircraft to its final destination the signed copy of the load manifest. This will be placed with the trip paperwork which must also include at a minimum, the flight release, airworthiness release, pilot route certification and the completed flight plan that the PIC is responsible for obtaining. If needed see additional information for the required trip paperwork in the GOM.*

According to the Chief Loadmaster, National Airlines employed 13 loadmasters and three check loadmasters.

5.1.3 Loader Operator

The responsibilities for the load operator were defined in the National Airlines Weight and Balance Manual, Chapter 2 “Loading Information” page 2-4, and stated in part:

Responsible for the positioning and operation of cargo loader for transfer of freight to the aircraft. In performing this operation the loader operator:

- 1. Verifies the position number on the appropriate Load Planning Sheet.*
- 2. Checks proper sequencing of the load, position #1 loaded first then aft positions.*
- 3. If trained and qualified, he may also perform the responsibilities of the Loading Supervisor.*

5.1.4 Forklift Operator or Pallet Transport Operator

The responsibilities for the forklift operator or pallet transport operator were defined in the National Airlines Weight and Balance Manual, Chapter 2 “Loading Information” page 2-4, and stated in part:

Responsible for movement of freight to aircraft for loading.

- 1. Positions ULD's on loader for main deck loading. When using a forklift equipped with a scale, he may verify weights as indicated on Pallet Tags. In the event of a variance of (+/-) 300 pounds, the Load Preparer and or Loading Supervisor will be notified.*

5.1.5 Pilot in Command

The National Airlines Weight and Balance Manual, Chapter 6 “Responsibility and Authority” page 1-4, stated in part:

The Pilot In Command is responsible for ensuring that all weights and center of gravity details provided on the load manifest are within the prescribed operating conditions and limitations for the flight. The Pilot In Command will cross check the Operational Empty Weight (OEW) on the flight release with OEW on the loadsheet to determine the following:

- *That the crew complement (Number of flightcrew and number of flight attendants on the load sheet matches the actual complement*
- *That the OEW on the load sheet matches the OEW on the flight release.*
- *Furthermore the Pilot In Command confirms that the load manifest is correctly signed and copy is placed in the trip envelope to be carried to destination along with the NAVTEC flight release and airworthiness release. If there are discrepancies found the PIC must contact the Flight Follower and resolve any differences prior to accepting the load manifest and the flight release.*

In addition, the National Airlines Cargo Operations Manual, Section 1.8.4 “Pilot in Command”, page 1-8, stated the following:

The PIC is responsible for ensuring that National Airlines procedures are followed by the contracted ground handlers. He may delegate the authority to a Loading Supervisor, but not the responsibility.⁵⁸

6.0 Camp Bastion Loading

6.1 Pre-load planning

National Air Cargo Holdings was the holding group for two subsidiaries, National Air Cargo Group, Inc. doing business as (dba) National Airlines (based in Orlando, Florida) and National Air Cargo, FZE (based in Dubai, UAE).⁵⁹ National Airlines operated both passenger (B757) and cargo (B747-400) operations. For the cargo operations, National Air Cargo was responsible for load planning, cargo/pallet build up, and aircraft loading of National Airlines’ B747-400, while National Airlines transported the cargo. On April 26, 2013, the load planning department for National Air Cargo in Dubai, UAE contacted the National Airlines Chief Loadmaster advising that they (National Air Cargo) were planning to load 5 Mine Resistant Ambush Protected (MRAP) armored military vehicles on the National Airlines flight from Camp Bastion to Dubai on April 29, 2013. The text of the email sent to the National Airlines Chief Loadmaster from the National Air Cargo load planning department in Dubai stated the following:⁶⁰

⁵⁸ According to a National Airlines B747-400 Check Airman, there were guidelines on how to strap down cargo in the “loading manual,” but pilots are not trained or evaluated on that information. See Attachment 1 – Interview Summaries.

⁵⁹ See Attachment 39 – Organizational Charts.

⁶⁰ See Attachment 30 – Bastion Loading.

We are expecting 3xMRAP (18800 to 19000KG, including ULD/Shoring) from OAZI on next NAL Flight rotation to DWC ,vehicles are built on sandwich pallet with support of enough shoring . Kindly let us know the Laudability .

In addition to these three vehicle we are looking two more vehicle weighing around 12000KG each on same flight.

Please let us know any additional precaution we need to take before confirming the load.

The National Airlines Chief Loadmaster responded the same day via email with the following:⁶¹

That shouldn't be a problem. We just need to make sure we have enough ballast in the front to prevent the aircraft from tipping and for weight and balance.

According to documentation provided to the NTSB, three of the vehicles were 4-wheel drive MRAP "Cougars" weighing 18 tons each, and two MRAP All-terrain Vehicles (MRAP ATV, or MATV's) weighing 12 tons each, and all were to be loaded on the main deck of the accident airplane. According to interviews, National Airlines had transported vehicles similar to the 12-ton MATVs onboard their B747-400 prior to the accident, but the Camp Bastion load was the first time National Air Cargo had ever attempted to load an 18-ton Cougar on a National Airlines B747-400, and the first time National Airlines had attempted to transport 18-ton Cougars on the B747-400.⁶²

The National Airlines Director of Safety, Security and Quality told NTSB Staff that a risk analysis was not conducted on the carriage of heavy, center-loaded floating palletized loads like the MRAPs or MATVs, and added that he was not involved in the decision to begin carrying large, heavy military vehicles, nor was the Safety department asked to provide input.⁶³ In addition, according to National Airlines records, of the accident crew operating the Camp Bastion flight, only one mechanic and the augmented first officer had prior experience operating a B747-400 with MRAPs. The accident captain, first officer, and loadmaster had never operated a National Airlines flight with an MRAP as part of the cargo load (either the 12-ton or 18-ton version).⁶⁴

On April 26, 2013, the National Air Cargo Dubai load planner sent a pre-planned load to Camp Bastion indicating an initial load of 95,313 kilograms (235,752 pounds) that included the five MRAPs.⁶⁵

According to the Vice President of Ground Ops Middle East for National Air Cargo, there was no special communication regarding the heavy loads like the Cougar, and National Air Cargo and National Airlines did not do a risk assessment on the larger MRAP, only an evaluation. He

⁶¹ See Attachment 30 – Bastion Loading.

⁶² See Attachment 1 – Interview Summaries.

⁶³ See Attachment 1 – Interview Summaries.

⁶⁴ See Attachment 9 – Flight Crew Experience with MRAPs.

⁶⁵ Source: April 26, 2013 email from Dubai at National Air Cargo to CAPCON load planner, RE: Payload N952CA/27th Apr. For additional information, see Attachment XX – Bastion Loading Documents, and Attachment 30 – Bastion Loading.

said there was no specific SOP (standard operating procedure) for the loading of an 18-ton Cougar, and said there was no demonstration done to teach the loading of one of these type of MRAPs to National Air Cargo loaders.⁶⁶

When asked by NTSB Staff if there was a conscious decision by National Airlines to approve the loading of the 18-ton Cougars, the National Airlines Chief Loadmaster told NTSB Staff that it was up to National Air Cargo, and as the operator “you call, we haul.”⁶⁷ National Air Cargo gave National Airlines the freight, and the Chief Loadmaster told NTSB Staff “he did not know about the bidding process.”⁶⁸ National Airlines did not provide special guidance, strapping diagrams, or photos to the loadmasters for special loads similar to the MRAPs.

6.2 Pallet build-up and Shoring

According to interviews, National Air Cargo employees began loading the accident airplane on the morning of April 29, 2013. The first 12-ton MRAP was loaded using the National Air Cargo 14-ton lift, and placed in the forward section of the main deck. Since the 18-ton Cougars were too heavy for the National Air Cargo 14-ton lift, loading of the remaining MRAPs was delayed until about 0830 local time while the ground crew waited for the military to arrive with their 60-ton Atlas “K-loader” so the 18-ton Cougars could be lifted.

Because the MRAPs were too large to drive onto the main deck of the B747-400, each of the MRAPs were placed on pallets. The pallets and vehicles were then loaded on the main deck of the B747-400. Because the pallets were loaded into the center of the main deck and not attached/restrained by the side rails of the main deck floor (Telair system), the pallets were called center-loaded “floating pallets” and required to be restrained with straps attached to the main deck. The National Airlines Cargo Operations Manual, Chapter 6: Special Loads, page 6-2, stated in part:

*Floating pallets are defined as pallets which are oriented in the aircraft in such a manner that the forward and aft pallet end restraint fittings and side rails will not all engage the pallet to restrain it, and it might not be possible to place all pallet end restraint fittings in proximity of the floating pallet in the locked position.*⁶⁹

According to the National Air Cargo Operations Specialist who supervised the pallet build-up and loading of the accident airplane in Camp Bastion, the 12-ton MATVs were loaded onto a single “PGF” pallet.

⁶⁶ See Attachment 1 – Interview Summaries.

⁶⁷ See Attachment 1 – Interview Summaries.

⁶⁸ See Attachment 1 – Interview Summaries.

⁶⁹ Source: National Airlines Cargo Operations Manual, Chapter 6: Special Loads, page 6-2.

20 FT PALLET

IATA ULD Code, PGA 20ft flat pallet with net
Also known as, PGA, PGE, PGF, PSA, PSG,
P7A,
P7E, P7F, P7G
Classification, M-6
Rate Class, Type 1
Suitable for B747F, B747 Combi
Maximum volume, 33.2 cu m (1,174 cu ft)
Maximum gross weight 11,340 kg (25,000 lb)

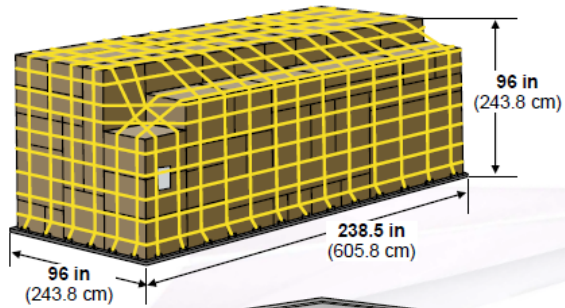

Figure 2: Sample PGF pallet.⁷⁰

The Specialist then used 14 chains to secure the 12-ton MATV to the pallet.⁷¹ For the 18-ton Cougars, the Specialist built a “double-pallet” comprised of one pallet on top of another pallet, with plywood between the two pallets to reduce friction. The two pallets were attached to each other with straps, three lengthwise and two widthwise, for five straps total. Between the pallets was a thin sheet of plywood. According to the Specialist, they were the same straps used on the tie down to the airplane.



Photo 2: Photo of double pallet build-up demonstration for 18-ton Cougar.⁷²

⁷⁰ Source: Source: National Airlines Cargo Operations Manual, page 2-11.

⁷¹ According to one of the loaders of the accident load in Bastion, 2 chains were attached to the bottom, 2 backwards and forwards, and the same on the other side. The axle chains were the only ones attached to the top pallet for the double palleted Cougars. For additional information, see Attachment 1 – Interview Summaries.

⁷² Photo taken by Operations Group Chairman in Bagram on May 7, 2013. On May 6-7, 2013, the Operations



Photo 3: Close-up of double pallet strap securing the two pallets.⁷³

The Cougar was then placed on the double pallet, and chained to the pallet. The loaders were able to drive two of the Cougars onto the pallets, but they had to use a fork lift to lift the third onto the pallet. According to interviews, they chained the Cougars down with eight chains attached to the top pallet and six chains attached to the bottom pallet for a total of 14 chains. Two chains were attached to the bottom, and two backwards and forwards, and the same on the other side of the vehicle. The axle chains were the only ones attached to the top pallet.

The National Air Cargo Operations Specialist who was in charge of the pallet build-up for the accident flight load told NTSB Staff he did not have an SOP (standard operating procedure) for any particular load, there was no specific manual that they followed when building the pallets, and he did not know the load capacity of a pallet.⁷⁴ He further said that the only manual he had for reference in Camp Bastion was a dangerous goods manual. National Air Cargo staff did not have a copy of the National Airlines Cargo Operations Manual in Camp Bastion, and did not have a computer to view any manuals online.⁷⁵ The National Airlines Chief Loadmaster told

Group requested the Camp Bastion loaders who worked on the accident airplane load in Camp Bastion demonstrate how they built up the double pallets used for the 12-ton MATVs and 18-ton Cougars. The loaders in Camp Bastion flew to Bagram, and using National Air Cargo equipment and supplies provided a demonstration on how they built the pallets used on that accident airplane, shored and secured the MRAPs to the pallets (both the 12-ton and 18-ton vehicles). For additional photos, see Attachment 29 – Bastion Loading Demo Photos.

⁷³ Photo taken by Operations Group Chairman in Bagram on May 7, 2013. For additional photos, see Attachment 29 – Bastion Loading Demo Photos.

⁷⁴ See Attachment 1 – Interview Summaries.

⁷⁵ In addition, National Air Cargo loaders and National Airlines loadmasters were trained separately. See Section

NTSB Staff that double pallets were not addressed in the National Airlines Cargo Operations Manual on how they should be built.⁷⁶ The National Airlines Cargo Operations Manual, Chapter 3 “Cargo Loading and Unloading Procedures”, page 3-1 stated in part:

All cargo operations personnel involved with the loading of an aircraft are required to use the procedures, instructions, and information outlined in this manual. Checklists and forms contained in this manual and the General Operations Manual must be used to control the loading of an airplane. Information provided to the Pilot-in-Command (PIC) must be accurate so the maximum allowable weight of the aircraft is not exceeded.

In addition, the National Airlines Cargo Vendor Prequalification Form (Cargo Operations Manual, page 10-7) had the following vendor checklist items:

14. Does the vendor have in their possession a current copy of the National Airlines Cargo Operations Manual?⁷⁷

15. Does the vendor have procedures for the handling of special or oversized loads?

Due to the weight of each of the vehicles, shoring (load spreading) was used underneath each vehicle via wood blocks. The National Airlines Cargo Operations Manual, Chapter 6: Special Loads, page 6-11, stated in part:

4.5 SHORING REQUIREMENTS

Shoring is used to spread highly concentrated loads over a greater base area than that occupied by the cargo alone. Use of shoring permits carrying a load with a higher concentration than would be normally allowed. It is also used to protect ULD⁷⁸ surfaces from damage caused by vehicle cleats, steel wheel rims, and packing case studs or protrusions. Cargo exceeding the rated floor bearing capacity of a ULD or aircraft will require shoring to distribute the load over a greater area. Shoring used for weight distribution may be ordinary planking laid beneath the cargo, or it may be composed of plywood sheets.⁷⁹

The National Airlines Cargo Operations Manual, Section 5.10 “Shoring” stated in part:

Shoring can become necessary for heavy (typically over 2000 lb./1000 kg) concentrated loads in order to meet either the applicable aircraft area load or running load limitations, or both.

Note: *At least elementary shoring can also become necessary for practical reasons, even in instances where neither the area load or the running load limitations are exceeded, on a plate aluminum ASI491B (ISO 4171, IATA 50/1) type pallet in order to avoid local*

14.2 Loadmaster Training of this Factual Report.

⁷⁶ See Attachment 1 – Interview Summaries.

⁷⁷ The vendor in Camp Bastion was National Air Cargo.

⁷⁸ A unit load device (ULD) is a pallet or container used to load luggage, freight, and mail on wide-body aircraft and specific narrow-body aircraft.

⁷⁹ Source: National Airlines Cargo Operations Manual, Chapter 6: Special Loads, page 6-11.

deformation which might render it difficult to move on rollerized conveyors. For example, an automobile directly loaded onto such a pallet usually does not exceed either limitation. Yet its wheels will create local base sheet deformation, which should be avoided by placing sufficiently stiff material, e.g. thick and long enough planks, below each wheel -unnecessary precaution with a heavy duty pallet.

Accordingly, shoring can be performed either laterally in relation to the aircraft centerline (area load limitation), or longitudinally (running load limitation), or both simultaneously .

On April 27, 2013, the National Air Cargo load planning department in Dubai sent Camp Bastion National Air Cargo loaders photos of examples of shoring to use for the Camp Bastion load.⁸⁰ The Dubai load planning department did not provide the Camp Bastion loaders with tie down or strapping instructions for securing the MRAPs on the main deck of the B747-400. In addition, National Airlines did not provide the accident loadmaster any special tie down instructions or strapping plans for securing the MRAPs on the main deck of the accident airplane.

According to interviews, for the shoring of the Cougars, the Camp Bastion crew put one shore under the front axle and rear axle, and one in the center. They then let air out of the tires to allow the vehicle to rest on the shoring.⁸¹

According to the National Airlines Chief Loadmaster, the Cargo Operations Manual had a section on shoring that gave guidelines on shoring, but it was up to the loadmaster to determine the amount of shoring based on his experience. As previously written in this Factual Report, according to National Airlines, the accident loadmaster had never loaded a MRAP on a National Airlines flight. The National Airlines Chief Loadmaster further said there was no additional guidance provided to the loadmasters on how to shore or load MRAPs, either the 12 ton or 18 ton units, and it was their policy for the loadmasters to use their judgment on proper shoring.⁸²

According to the loaders in Camp Bastion, the MRAPs and MATVs were center loaded on the main deck of the accident airplane. The front vehicle was a 12-ton MATV, followed by the three 18-ton Cougars. The aft most vehicle was a 12-ton MATV, and located near the main cargo loading door in the aft of the airplane. According to the National Air Cargo loaders, the pallets were about 3-4 inches apart, and none of the floor locks were used on the main deck except for the aft most pallet. The National Air Cargo loaders in Camp Bastion also told NTSB staff that in the rear of the main deck, they loaded a T2 pallet (two pallets married to each other) with a light load of scaffolding, secured by the bear claw locks in the floor. The National Airlines Cargo Operations Manual, Chapter 6: Special Loads, page 6-3 stated, in part:

⁸⁰ For photos of shoring samples sent to Camp Bastion, see Attachment 30 – Bastion Loading.

⁸¹ Once the shoring was in place, the vehicle had a system called the Central Tire Inflation System (CTIS) which enabled the tires to be inflated or deflated by activating a switch from within the cabin of the vehicle. Air pressure was then taken out of the tires and the MATV rested on the shoring to distribute the weight equally onto the pallet for strapping.

⁸² See Attachment 1 – Interview Summaries.

Note:

In all floating pallet installations, the Loading Supervisors shall ensure and certify that all pallet end restraint fittings that are not beneath the floating pallet assembly or blocked by the floating pallet are in the locked position prior to closure of the main cargo door on departure.

6.3 Camp Bastion Pallet Build-up Demonstration Photos

On May 6-7, 2013, the Operations Group requested the National Air Cargo Camp Bastion loaders who worked on the accident airplane cargo load at Camp Bastion demonstrate how they built up the pallets and double pallets used for the 12-ton MATVs and 18-ton Cougars. The loaders from Camp Bastion flew to Bagram, and using National Air Cargo equipment and supplies, provided a demonstration to the NTSB on how they built the pallets used on the accident airplane and shored and secured the MRAPs to the pallets (both the 12-ton and 18-ton vehicles).

6.3.1 12-Ton MATV Build-up Demonstration Photos⁸³

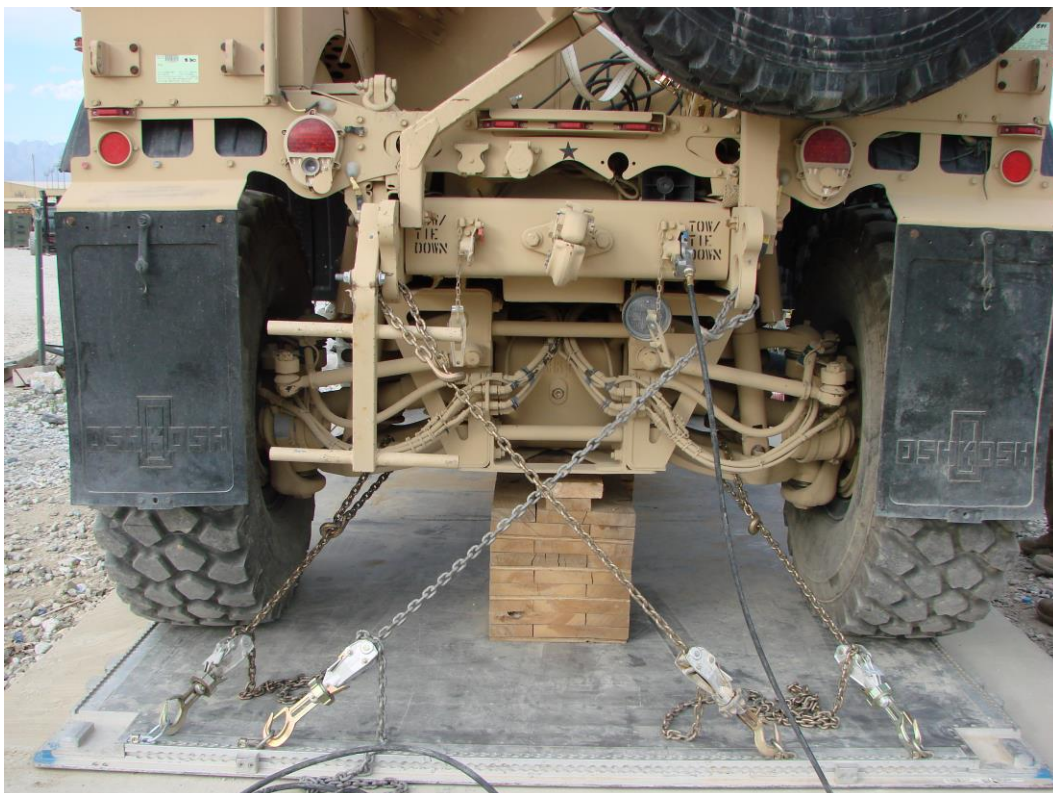

Photo 4: Photo of shoring demonstration of a 12-ton MATV (aft view).

⁸³ Photos taken by the NTSB Operations Group Chairman on May 6, 2013. For additional photos, see Attachment 29 – Bastion Loading Demo Photos.



Photo 5: Photo of shoring demonstration of a 12-ton MATV (side view).



Photo 6: Photo of shoring demonstration of a 12-ton MATV (front view).

6.3.2 18-ton Cougar Build-up Demonstration Photos⁸⁴



Photo 7: Photo of shoring demonstration of a 18-ton Cougar (front view).

⁸⁴ Photos taken by the NTSB Operations Group Chairman on May 7, 2013. For additional photos, see Attachment 29 – Bastion Loading Demo Photos.



Photo 8: Photo of shoring demonstration of a 18-ton Cougar (side view).



Photo 9: Photo of shoring demonstration of a 18-ton Cougar (aft view).

6.4 Securing to the Main Deck⁸⁵

During the fuel stop in Bagram, the cockpit crew was notified of a damaged strap and a possible load shift on the main deck of the accident airplane. To secure the pallets to the main deck of the B747-400, the accident loadmaster had told the Camp Bastion loaders to secure the vehicles using 5,000 pound rated straps. According to the Camp Bastion loaders, the accident loadmaster told them to secure the 12-ton MATVs with a total of 24 straps, and secure the 18-ton Cougars with a total of 26 straps. The National Air Cargo Operations Specialist in charge of loading the airplane in Camp Bastion told NTSB Staff that he walked the main deck of the accident airplane with the accident loadmaster to inspect the securing of the MRAPs. He did not see the pilots of the accident airplane inspect the load.⁸⁶

The National Airlines Chief Loadmaster told NTSB Staff that while the large vehicles were “different”, it was not different on how you strapped them down to the airplane. In interviews with the National Air Cargo ground crew in Bagram, NTSB Staff was told personnel from the Dubai offices conducted “some classes on how to palletize a ‘Stryker’, which was about 12-13 tons.”⁸⁷ The National Airlines Cargo Operations Manual, Chapter 6: Special Loads, page 6-5, stated, in part:

4.1 GENERAL

Air cargo is subjected to forces caused by maneuvering, rough air, rough landing, extreme flight attitudes and may be subjected to extreme forces due to emergency landings. These forces will shift cargo unless it is secured firmly in the aircraft. During normal operation, the aircraft and cargo are moving rapidly forward. If the aircraft is slowed suddenly, the cargo will tend to continue moving forward. This forward tendency is likely to be the strongest force encountered by the cargo. In addition, there are forces in other directions: vertical, lateral, and rearward (aft).

*Restraint criteria for air cargo are based upon the weight of each cargo unit and the dynamic forces (loads) imposed upon each unit due to a change in motion (changing direction, slowing down, speeding up). The dynamic forces increase as the rate of change in motion increases. An object that is slowed down over a long distance has lower dynamic forces than the same object when stopped in a short distance. All cargo on an aircraft, except that placed in bulk compartments, shall be restrained so it will not shift during any flight conditions normally experienced by the aircraft. CARGO SHALL BE RESTRAINED FOR LOADS IN ALL DIRECTIONS.*⁸⁸

The National Airlines Cargo Operations Manual, Chapter 6, “Special Loads”, page 6-11 stated in part:

⁸⁵ Section 6.4 Securing to the Main Deck of this Factual Report primarily deals with operational considerations regarding the securing of loads to the B747 main deck at National Airlines. For detailed information regarding the load securing on the accident flight, see the Structures Group Chairman’s Factual Report.

⁸⁶ For additional information, see Section 13.1.2 “Flight Crew Pre-flight of Cargo” of this Factual Report.

⁸⁷ The IAV Stryker is a family of eight-wheeled, armored fighting vehicles produced by General Dynamics Land Systems for the United States Army. It has 4-wheel drive (8x4) and can be switched to all-wheel drive (8x8). For additional Stryker build-up information, see Attachment 16 – National Air Cargo Stryker Prep.

⁸⁸ Source: National Airlines Cargo Operations Manual, Chapter 6: Special Loads, page 6-5.

4.4 CALCULATION OF RESTRAINT

Cargo must be restrained so it will not shift because of loads resulting from dynamic forces encountered during takeoff, flight, and landing. The restraint must be adequate for the greatest load that may result. These loads are expressed in terms of cargo-weight times the applicable load factor. If a cargo unit is subjected to a load equal to 1.5 times its weight, it must be restrained for a load factor of 1.5 to prevent it from shifting. If the calculation result in an odd number, use the next highest number of tiedowns. Use good sense with heavy and high density objects. Always use extra straps - it does no good when they are lying on the floor.

The National Airlines Cargo Operations Manual, Chapter 6 “Special Loads,” page 6-2, stated in part:

Prior to loading Oversize BIG and/or OHG items, ensure that there is sufficient and suitable tie-down positions available, and if necessary, raise the load above the pallet surface to gain access to, or make more tie-downs available.⁸⁹

According to the National Airlines Chief Loadmaster, the guidance the loadmasters used to tie down floating pallets included using 75% of the strap allowance. There were no special instructions on strapping the 18 ton Cougars other than the straps had to have a 20 inch separation. There were no diagrams or photos provided to the loadmasters on what an 18-ton Cougar should look like when tied down, and the National Airlines Chief Loadmaster did not know what National Air Cargo had sent their loaders in Camp Bastion for guidance on pallet build up or loading of the MRAPs and MATVs.⁹⁰

The National Airlines Chief Loadmaster told NTSB Staff that, to his knowledge, there was nothing in their Cargo Operations Manual restricting them from using the seat tracks on the floor to secure the vehicles. He said that post-accident, they had reviewed the Boeing manual, and there were restrictions to which seat tracks could be used and the specific loading for those tracks. The Chief Loadmaster further said that he looked at the Telair manual and Boeing manual, and had extracted charts from both and inserted them into the Cargo Operations Manual. Regarding restraining to the seat tracks, National Airlines had deferred to the Boeing manual. The National Airlines Chief Loadmaster also told NTSB Staff that in his 17 years as a loadmaster, about 95% of the straps he saw to secure floating pallets were to the seat tracks and not to the side rails. At the time of the accident, National Airlines provided no restrictions to tie down points on the seat tracks of the main deck of the B747-400.⁹¹

According to the Operations Specialist who loaded the Camp Bastion load on the accident airplane, National Air Cargo had a “ULD department” that was responsible for the inventory of straps and chains, and responsible for inspecting the chains and straps used onboard National Airlines flights.⁹² The Vice President of Ground Ops Middle East for National Air Cargo told

⁸⁹ Source: National Airlines Cargo Operations Manual, Chapter 6: Special Loads, page 6-2.

⁹⁰ See Attachment 1 – Interview Summaries.

⁹¹ See Attachment 1 – Interview Summaries.

⁹² According to the FAA Principal Maintenance Inspector (PMI), he had never heard of a “ULD group” within

NTSB Staff that the ULD department at National Air Cargo coordinated strap and chain inventory. He further said there was no specific training for that position, and there was no quality assurance program for the straps.⁹³ He also stated that they had not needed to replace any strap inventory, and there was no training for the ULD inspector to tell when a strap was no longer safe. He said the airline provided the guidelines for the type of strap or chains required, using IATA⁹⁴ standards. The National Airlines Cargo Operations Manual, Section 6.0 “Pallet Tiedown,” page 2-25 stated in part:

Cargo Straps must be checked prior to their use for excessive wear or cuts, working hardware may be deformed but must operable, if an expiration date is shown it must not exceed that date or if only month and year are shown it may not exceed the last day of month shown. Straps should be traceable to standard such as a TSO-C172, ISO 16049-1, SAE AS 5385A, IATA UTM60/2 and may be of the ratchet or over center buckle type. Any cargo strap which has exceeded its expiration date cannot be used and must be returned to KYIP cargo for a check for its usefulness and re-validation, in accordance with Company procedures.

Further, the National Airlines Cargo Operations Manual, Section 1.1 “Load Manifest” page 3-2 stated the following:

During the pallet inspection process before loading, the Loadmaster or qualified individual shall not only inspect the pallet, nets and straps for airworthiness but for the following information on the ULD pallet tag must be the same shown on the OP-2, OP-2B, OP-30 and OP-30M;

- *Pallet ID number*
- *ULD Weight. (OP-30 and OP-30M only, If the weights are shown in Lbs on the ULD pallet tag then it must be converted to Kgs to ensure both ULD weight and OP-30 and OP-30M match).*
- *ULD Destination*

Advisory Circular (AC) 120-85 “Air Cargo Operations” Section 316 “Using Qualified Nets and Straps” stated in part:

Some approved cargo restraint systems permit the use of tiedown straps as a primary restraint means. These systems generally provide the instructions for determining the quantity and arrangement of straps required to properly restrain the cargo. In many cases the strap specification provided by the OEM⁹⁵ may be provided only as a required strap rating, for example, “5,000-Pound Rated Straps.” In this situation, the operator is responsible for obtaining FAA approval for the particular straps that it is using. The operator should have procedures for selecting or defining straps that meet the requirements of the approved cargo restraint system, ensuring that the purchased or manufactured straps meet the OEM requirements, and have procedures in place that

National that inspected cargo straps. See Attachment 1 – Interview Summaries.

⁹³ See Attachment 1 – Interview Summaries.

⁹⁴ International Air Transport Association.

⁹⁵ Original equipment manufacturer.

*ensure the continued airworthiness of the straps. The straps approved for use by the operator should be uniquely identified (i.e., manufacturer part number) in the operator's operating manuals.*⁹⁶

6.5 Cargo Operations Manual Guidance for Motor Vehicles.

The National Airlines Cargo Operations Manual, Section 4.9, "Motor Vehicles/Wheeled Cargo," page 6-16 stated in part:

4.9.1 General

In the handling and loading of BIG Items, following procedures should be adhered to in handling and loading automobiles.

- 1. Fuel tanks shall be empty; except diesel engines automobiles. Refer to current IATA Restricted Articles Regulations.*
- 2. Batteries can remain installed provided they are securely fastened in an upright position.*
- 3. To limit automobiles movement, wheels may be chocked.*
- 4. The handbrake shall be set during ground/air transportation.*
- 5. The keys shall remain in the automobiles or accessible with paperwork.*

4.9.2 Roll In

- 1. Before rolling the automobile from the loader into the aircraft, empty pallets shall be positioned in the compartment.*
- 2. The automobile shall be secured to the pallet or to the aircraft tiedown points.*
- 3. The Company principal base of operation or down line destination of unloading shall be informed when the rollout method is used to ensure that an empty pallet is placed on the loader upon arrival to unload the automobile.*

4.9.3 Tie-Down

- 1. The automobile shall be secured on the pallet or to the aircraft structure, depending on the method of loading and on the type of aircraft.*
- 2. Parts of the vehicle shall be used for tiedown. The use of tiedown to moving parts, such as steering rods, suspension or wheels, etc. shall be avoided.*
- 3. Care should be taken not to damage paint work.*

4.9.4 Tire Loads

Motor vehicles, trailers, and other cargo with pneumatic tires may be placed on or maneuvered across pallets as long as:

- 1. The total load per tire is no more than 850 lbs. For vehicles, assume even distribution of weight among the 4 wheels unless it is a pick-up, or has other items loaded in it which may put more weight on one axle. If necessary, drive the vehicle across scales one axle at a time to determine each axle weight.*
- 2. The footprint of each tire is at least 48 square inches. Use the following procedure to determine the area of the footprint:*
 - Park the vehicle on a flat surface.*

⁹⁶ For full text of the AC, see Attachment 35 - AC 120 85.

- Place marks on the surface as illustrated in Figure 6-18. on page 6-18.
- Move the vehicle and from these marks determine the Length and Width of the footprint.
- Since a tire footprint is elliptical, use this formula to calculate the actual area of the footprint: $(Length \times Width) \times .785 = Area$

Note:

To increase the footprint area, a tire may be deflated by up to 20% of its capacity.



Figure 6-18. Measurement of Tire Footprint

6.6 Camp Bastion Loading Photos

6.6.1 Military Photos

The following photos were provided to the NTSB by A1C Sarah Lipfird, USAF, who assisted National Air Cargo with the loading of the 18 ton Cougars onto N949CA and operated the 60K loader.⁹⁷ The photos depict the actual loading of the accident load in Camp Bastion on April 29, 2013.

⁹⁷ See Attachment 22 - Witness Statements.



Photo 10: Photo of Camp Bastion loading provided to the NTSB by A1C Sarah Lipfird, USAF, taken April 29, 2013.



Photo 11: Photo of Camp Bastion loading provided to the NTSB by A1C Sarah Lipfird, USAF, taken April 29, 2013.



Photo 12: Photo of Camp Bastion loading provided to the NTSB by A1C Sarah Lipfird, USAF, taken April 29, 2013.



Photo 13: Photo of Camp Bastion loading provided to the NTSB by A1C Sarah Lipfird, USAF, taken April 29, 2013.

6.6.2 National Air Cargo Photos

The following photos were provided to the NTSB by National Air Cargo, depicting the actual loading of the accident load in Camp Bastion on April 29, 2013.



Photo 14: Photo provided to the NTSB by National Air Cargo, depicting the accident load in Camp Bastion on April 29, 2013.



Photo 15: Photo provided to the NTSB by National Air Cargo, depicting the accident load in Camp Bastion on April 29, 2013.



Photo 16: Photo provided to the NTSB by National Air Cargo, depicting the accident load in Camp Bastion on April 29, 2013.



Photo 17: Photo provided to the NTSB by National Air Cargo, depicting the accident load in Camp Bastion on April 29, 2013.



Photo 18: Photo provided to the NTSB by National Air Cargo, depicting the accident load in Camp Bastion on April 29, 2013.



Photo 19: Photo provided to the NTSB by National Air Cargo, depicting the accident load in Camp Bastion on April 29, 2013.

7.0 Weight and Balance

Weight limits for the accident airplane were found in the National Airlines Flight Crew Operating Manual, Limitations page L.10.4.⁹⁸ The dispatch release, computed by the dispatcher at 2220Z on April 28, 2013, called for a total fuel load of 44,000 kg. According to recorded data, the crew elected to increase the fuel load in Bagram to 48,000 kg.

The National Airlines General Operations Manual, Section 12.1.7 “US Military/Department of Defense Flights” page 6-36, stated:

When conducting US Military / Department of Defense flights, actual passenger, cargo and baggage weights will be used. These weights will be provided and obtained from

⁹⁸ Limits and specifications were derived directly from Boeing's FAA Approved AFM, including recommended Non-AFM Limits.

AMC⁹⁹ or the facility processing the passengers, cargo, and baggage for the flight. This should be accomplished not less than eight hours preceding the scheduled operation.

The final product of Weight and Balance Loading Process was a completed Load Manifest (OP-31C). It ensured that the aircraft was loaded in such a way that any weight restriction had not been or would not be exceeded and that the center of gravity was and would remain within its envelope for the entire flight.

The National Airlines Weight and Balance Manual, Section 8.8 “Load Manifest” page 1-11 stated the following in part:

The Captain, Loadmaster or other qualified personnel who have been properly trained, may be delegated the authority for performing the weight and balance computation for each flight. The Captain is responsible for ensuring that the aircraft does not exceed any performance limited weight or center of gravity limits. The Captain has final responsibility.

WEIGHT & BALANCE / PERFORMANCE (All weights in kilograms) (maximum weights in bold)	
Basic Operating Weight	164,540
Pilot Weights (Captain and FO)	included
Passenger Weight (5 ACMs) ¹⁰⁰	550
Baggage/Cargo Weight	94,119
Zero Fuel Weight	259,209
Maximum Zero Fuel Weight	276,691
Fuel Weight (takeoff)	48,000
Ramp Weight	307,209
Maximum Taxi Weight	395,986
Taxi Fuel Burn (estimated)	900
Actual Takeoff Weight	306,309
Maximum Takeoff Weight	394,625
Estimated Enroute Fuel Burn	31,408
Estimated Landing Weight (Dubai)	274,901
Maximum Landing Weight	295,742
Takeoff CG (Center of Gravity) (% MAC)	30.4
Takeoff CG range limits (% MAC)	15.5 – 33.0
Takeoff trim – Stabilizer 0-15%	3.7
Stabilizer 15-30%	4.1
Takeoff Flap Setting	10
V ₁ / V _R /V ₂ ¹⁰¹	140/153/167

⁹⁹ Air Mobility Command. Air Mobility Command, activated on June 1, 1992, is a major command headquartered at Scott Air Force Base, Ill. AMC provides worldwide cargo and passenger delivery, air refueling and aeromedical evacuation. The command also transports humanitarian supplies to hurricane, flood and earthquake victims both at home and around the world. Source: <http://www.amc.af.mil/library/factsheets/factsheet.asp?id=229>.

¹⁰⁰ Additional crewmembers.

¹⁰¹ According to 14 CFR 1.2, V₁ is the maximum speed in the takeoff at which the pilot must take the first action (such as applying brakes, reducing thrust, or deploying speed brakes) to stop the airplane within the accelerate-stop

7.1 Weight and Balance Trim Sheet



B747-400BCF MILITARY LOADPLANNER (OP-31C)

Z-DATE		FLT. NO.		ORIG		DEST	
ACFT REG				CREW #	2	ACM/SPN #	
RWY TEMP		° C		WIND		ALTIMETER	
ZERO WIND WEIGHT						T/O FLAP	RWY
HW -TW WT ADJUST						ACTUAL TOGW	
CLUTTER DECREMENT						FUEL BURN OFF	
SHORTENED RWY DECR-						ESTIMATED LAND WT =	
ANTI-SKID INOP DECR-							DEST RWY
MEL/CDL OR OTHER DECR-							
RWY LIMIT WT =							
STRUCT LIMIT WT	3	9	4	6	2	5	
CLIMB LIMIT							ALLOW LNDG WT
CLIMB DECREMENT							FUEL BURN OFF
ADJ CLIMB WT =							LNDG WT LMTD TOGW
							MAX ALLOW TOGW
							OBSTACLE
							RUNWAY
							NOISE
							STRUCT
							CLIMB
							TYPE LIMITATION
							LNDG WT

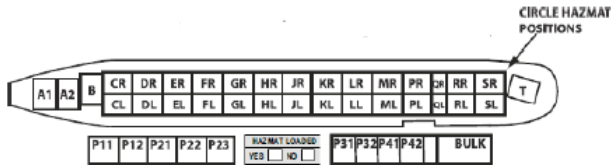

Figure 3: Sample B747-400BCF Weight and Balance Trim Sheet (Form OP-31C).¹⁰²

distance, which is a calculated distance defined in 14 CFR 25.109. V_1 is also the minimum speed in the takeoff at which, after a failure of an airplane's critical engine, the pilot can continue the takeoff and achieve the required height above the takeoff surface within the takeoff distance. According to 14 CFR 25.107, V_2 is the takeoff safety speed that must provide at least a minimum specified climb gradient in the event of a loss of power in one engine. V_R is rotation speed.

¹⁰² Source: National Airlines Cargo Operations Manual, page 10-10.

TOI NI 106.7
Flaps 10
MADP 1
EOAH 1000

NATIONAL

B747-400BCF COMPUTERIZED WEIGHT AND BALANCE PERFORMANCE (OP-31C)

Z-DATE	4-24-15	FLT. NO.	NCE102	ORIG	GAIX	DEST	OMDW
ACFT REG	N949CA	CREW #	2	ACN/SPN #	5		
RWY TEMP	8	WIND	120	12	ALTIMETER	29.98	FUEL DENSITY
ZERO WIND WEIGHT	334800			T/O FLAP	10	RWY	030
HW-TW WT ADJUST				ACTUAL TOGW	306	309	
CLUTTER DECREMENT				FUEL BURN OFF	31	408	
SHORTENED RWY DECR				ESTIMATED LAND WT =	274	901	
ANTI-SKID HIOP DECR				DEST RWY	300		
MEL/CDL OR OTHER DECR							
RWY LIMIT WT =	334800						
STRUCT LIMIT WT	394625			295742	ALLOW LNDG WT		
CLIMB LIMIT	388800			31408	FUEL BURN OFF		
CLIMB DECREMENT				327150	LNDG WT LMTD TOGW		
ADJ CLIMB WT =	388800						
				MAX ALLOW TOGW	327150		
				OSSTACLE		NOISE	TYPE LIMITATION
				RUNWAY		STRUCT	<input checked="" type="checkbox"/> LNDG WT
				BRK EMBRGY		CLIMB	

CIRCLE HAZMAT POSITIONS

CIRCLE HAZMAT POSITIONS

DISTRIBUTION: ORIGINAL- TRIP ENVELOPE
COPY - DEPARTURE STATION

14 CFR 121.665

SIGNATURES / EMP#

PREPARED BY [Redacted] EMP# 10222

[Redacted] EMP# 10070

CAPTAIN

Figure 4: Accident Flight's B747-400BCF Weight and Balance Trim Sheet (Form OP-31C).¹⁰³

8.0 Meteorological Information¹⁰⁴

Weather reported about the time of the accident (about 15:27 LT / 10:57 UTC):¹⁰⁵

KQSA 291155Z 33008G17KT 9999 -TSRA SCT050CB BKN090 BKN170 13/04 A2996 RMK CB OHD MOV N SLP139 60000 70000 51014

¹⁰³ Source: National Airlines.

¹⁰⁴ KQSA is the ICAO identifier for Bagram Air Force Base. OAIX is the ICAO code for Bagram Airfield.

¹⁰⁵ Source: US Air Force Form 3803. Weather information was reviewed by Mr. Mike Richards, Aviation Safety Investigator - Senior Meteorologist, NTSB.

KQSA 291059Z 35011G17KT 9999 FEW050 BKN065 BKN090 14/05 A2993 RMK WND DATA ESTMD ALSTG/SLP ESTMD

KQSA 291058Z 35011G17KT 9999 FEW050 BKN080CB BKN150 14/05 A2993 RMK LTG DSNT NW SLP124 WND DATA ESTMD ALSTG/SLP ESTMD

Accident occurred at about 1057Z.

KQSA 291055Z 02007KT 9999 FEW040 BKN080CB BKN150 18/06 A2994 RMK PK WND 06026/1005 WSHFT 1027 LTG DSNT NW CB DSNT NW SLP124 WND DATA ESTMD ALSTG/SLP ESTMD

KQSA 290955Z COR 10017G30KT 9999 SCT085 BKN140 BKN200 17/06 A2992 RMK PK WND 09032/0856 LTG DSNT NW CB DSNT E SLP213 WND DATA ESTMD ALSTG/SLP ESTMD COR 13

ATIS for the departure of the accident flight was information Victor and used the 0955 KQSA surface observation. Text for ATIS¹⁰⁶ information Victor was as follows:

bagram tower information victor zero nine five five observation wind one zero zero at one seven gust three zero sky condition eight thousand five hundred scattered ceiling one four thousand broken two zero thousand broken temperature one seven dew point six altimeter two niner niner two runway three in use expect visual approach airfield advisories taxiways lima charlie and alpha closed weather warnings moderate thunderstorm high winds greater than equal to thirty-five less than forty-five knots hail greater than equal to one quarter less than one half inch weather watches potential lightning within five weather advisories cross winds observed greater than equal twenty knots advise on initial contact information victor

9.0 Air Traffic Control¹⁰⁷

Air traffic control services at Bagram were provided through a government contract with Midwest ATC Service, Inc., a private sector company based in Overland Park, Kansas. For additional ATC information, see Attachment 5 – ATC. For ATC tower personnel interviews, see Attachment 22 - Witness Statements.

¹⁰⁶ Automatic Terminal Information Service (ATIS) is the continuous broadcast of recorded non-control information in selected high activity terminal areas. Its purpose is to improve controller effectiveness and to relieve frequency congestion by automating the repetitive transmission of essential but routine information. The information is continuously broadcast over a discrete VHF radio frequency or the voice portion of a local NAVAID. Arrival ATIS transmissions on a discrete VHF radio frequency are engineered according to the individual facility requirements, which would normally be a protected service volume of 20 NM to 60 NM from the ATIS site and a maximum altitude of 25,000 feet AGL. Source: Aeronautical Information Manual, Section 4-1-13.

¹⁰⁷ ATC information was reviewed by Ms. Betty Koschig, Senior Air Traffic Investigator, NTSB.

9.1 Bagram Tower Photos

Photos taken from the Bagram ATC Control Tower by the Operations Group Chairman on May 4, 2013 at Bagram Airfield:

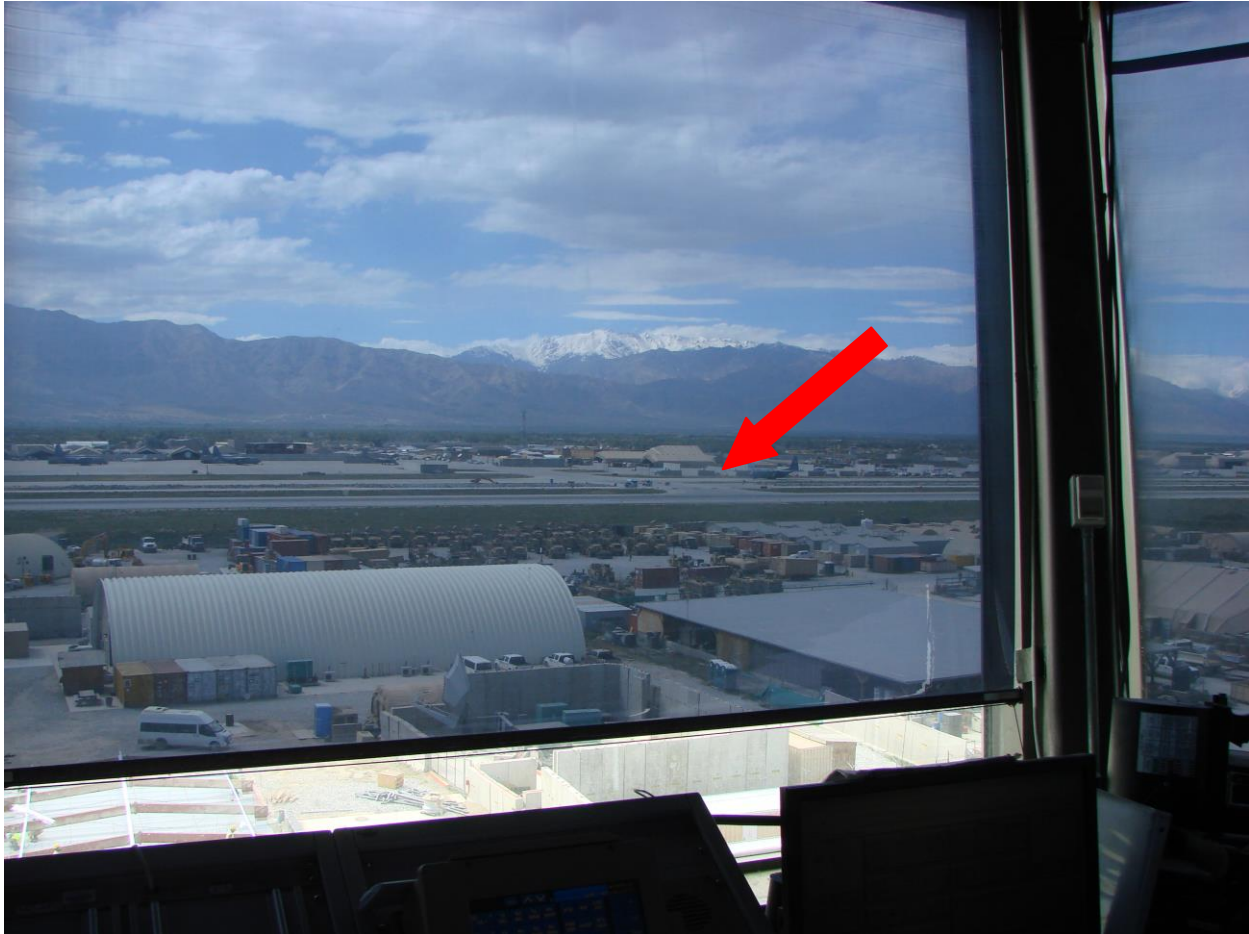

Photo 20: Tower view looking west. Arrow indicates location of taxiway “C”, the point closest to the rotation of the accident airplane.¹⁰⁸

¹⁰⁸ Photo taken by Operations Group Chairman on May 4, 2013.



Photo 21: Tower view looking southwest toward the departure end of runway 03.¹⁰⁹

10.0 Communications

There were no known communication difficulties.

11.0 Airport Information

Bagram Airfield was the largest U.S. military base in Afghanistan, located near the city of Bagram in the Parwan Province of Afghanistan. The base was mainly occupied by the U.S. Armed Forces, the International Security Assistance Force (ISAF) and minimally by the military of Afghanistan, and maintained by the Combined Joint Task Force 101st Airborne Division (CJTF-101). It was located at latitude/longitude of N 34° 56.88' /E 069° 15.9' with a field elevation of 4,895 feet above mean sea level. Runway 03/21 is 11,819 feet long and 151 feet wide.

According to interviews with ATC personnel in the control tower at the time of the accident, the taxi and takeoff of the accident airplane appeared normal, and rotation occurred around the Charlie intersection of runway 03. None of the controllers observed the accident airplane strike

¹⁰⁹ Photo taken by Operations Group Chairman on May 4, 2013.

its tail during rotation, and there was no smoke or debris observed from behind the airplane during the takeoff sequence by any observations in the ATC control tower.¹¹⁰

According to the Bagram ATC controllers, a C130 departed runway 03 about a minute prior to the accident flight. There was no foreign object damage (FOD) sweep of the runway following the C130 departure. Bagram typically conducted runway sweeps following departures of heavy airplanes like the B747, C-5, and the Antonovs, and the C130 departure did not require a runway sweep. The previous sweep of runway 03 prior to the accident occurred about 20 minutes prior to the accident. Following the accident, a sweep of runway 03 was conducted, and debris was located on the runway beginning near the Charlie intersection.

11.1 Airport Communications

There were no known communications issues.

¹¹⁰ One witness who observed the accident flight from the east side of the airport stated “the smoke coming out was a stream with small puffs that were graduated, and it was white, silhouetted against the sky. He said it was not coming out of any of the engine, and was not coming off the wings like a vortex. He did not hear any unusual sounds. He said the smoke trailed out just before it stopped climbing.” See Attachment 1 – Interview Summaries.

11.2 Charts¹¹¹

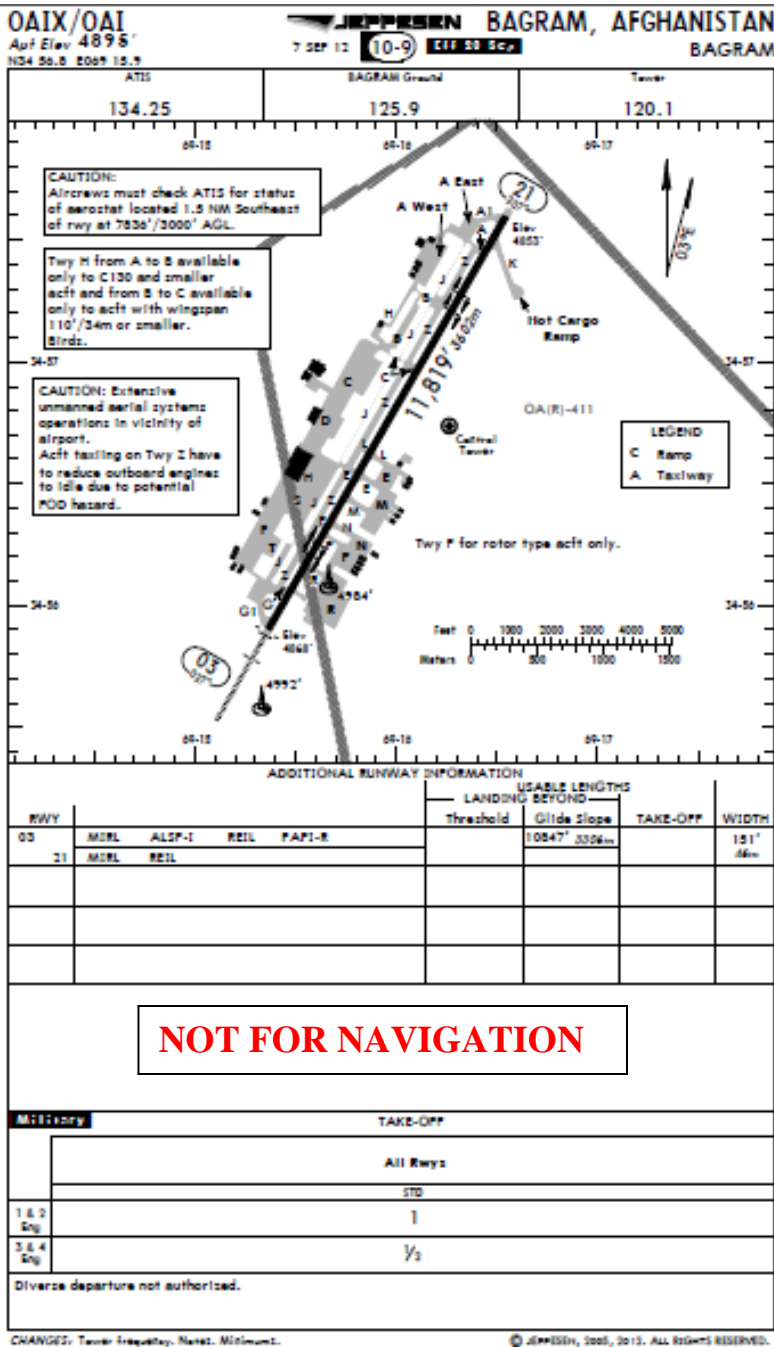

Figure 5: Bagram Airport Chart

12.0 Organizational and Management Information¹¹²

National Airlines began as Murray Air in 1985 under a 14 CFR 135 certificate, and headquartered at Willow Run Airport in Ypsilanti, Michigan. The company acquired their 14

¹¹¹ Source: Jeppesen. For additional chart information, see Attachment 31 – Charts.

¹¹² Source: FAA, review of company records and various interviews. See Attachment 1 – Interview Summaries.

CFR 121 certificate in 2005 and operates under both 121 and 135. In 2000, Daimler Chrysler contracted with Murray Air to operate long-haul freight flights utilizing two DC-8's operated under 14 CFR 125. In November 2006, Murray Air, Inc. was purchased by National Air Cargo and renamed National Air Cargo Group. The company did business as National Airlines and Murray Air Cargo. The company then began to transition their fleet from an all DC-8 cargo composition to a mix of B-747 cargo and B-757 passenger operations. The company received FAA approval for passenger operations in June 2011, and hired a corps of experienced flight attendants to begin operations on the B-757.

National Air Cargo Holdings was the holding group, and National Airlines and National Air Cargo were separate companies under the holding company.¹¹³ The airline operated on the 14 CFR Part 121 certificate, and contracted load planning services from National Air Cargo. The load planning was conducted at the Dubai World Central offices of National Air Cargo in Dubai, UAE.

According to the National Airlines Operations Specifications D085, the airline had three B-747-400 cargo airplanes and one B-757 passenger airplane on their certificate at the time of the accident.¹¹⁴ According to FAA records, the airline had a total of 230 employees, of which 43 were captains, 35 were FOs, 13 were check airmen, and 21 were flight attendants. Pilots were typically scheduled for 20 days on, 10 days off. National Airlines was hiring at the time of the accident, all due to growth in the B757 fleet. There was no recent hiring or planned hiring for the B747-400. The pilots, loadmasters and flight followers/dispatchers were all non-union.

The National Airlines Director of Operations was responsible for airline operations and for the quality of the National Airlines Weight and Balance Program. He had the authority to establish and modify the policies, procedures, instructions, and information for the National Airlines Weight and Balance Program process.¹¹⁵ The Director of Operations was also responsible for the quality of the Flight Operations Training Manual.¹¹⁶ He also had the authority to establish and modify that program. National Airlines had a System Chief Pilot and two Fleet Managers (757 and 747-400). Line Check Airmen reported to the System Chief Pilot through each Fleet Manager.

The National Airlines Director of Safety was responsible for SMS¹¹⁷ implementation, ASAP¹¹⁸ oversight, FOQA¹¹⁹ flight data analysis, and a joint responsibility for the security program with

¹¹³ See Attachment 39 – Organizational Charts.

¹¹⁴ See Attachment 7 – Operations Specifications.

¹¹⁵ Source: National Airlines Weight and Balance Manual, Chapter 6 “Responsibility and Authority.

¹¹⁶ Source: National Airlines Flight Operations Training Program, Chapter 1 “Responsibility and Authority.”

¹¹⁷ The FAA proposes to require each certificate holder operating under 14 CFR part 121 to develop and implement a safety management system (SMS) to improve the safety of their aviation related activities. A safety management system is a comprehensive, process-oriented approach to managing safety throughout an organization. An SMS includes an organization-wide safety policy; formal methods for identifying hazards, controlling, and continually assessing risk; and promotion of a safety culture. SMS stresses not only compliance with technical standards but increased emphasis on the overall safety performance of the organization. Source: FAA. According to the POI, National Airlines had just completed level 2 of SMS implementation before they moved to south Florida. (See Attachment 1 – Interview Summaries).

¹¹⁸ Aviation Safety Action Program. According to the FAA Advisory Circular 120-66B “Aviation Safety Action Program (ASAP)”, the objective of the ASAP is to encourage air carrier and repair station employees to voluntarily

the Director of Security. He was also a liaison to the Department of Defense (DoD) and their safety program. The Safety Department consisted of 3 employees; the Director, a safety assurance manager and a flight safety analyst. According to the Director of Safety, National Airlines had not conducted any LOSA¹²⁰ audit of their operations. For FOQA data, the QARs (quick access recorders) got downloaded through an Aerobytes server and they had problems sometimes with the downloads. The data was pulled, and after they looked at it, they assessed it to see if it concerned them, and would initiate an event report to the SRB (Safety Review Board), which the Director of Safety said was made up of “all the required air carrier management positions.”¹²¹ According to their review of the FOQA data, the current trends they saw on the B747 were hard landings and flap exceedance. They had a steering committee to review the FOQA information. The Director of Safety stated that National had exited level one of SMS development in January 2013, and planned to go to level two in March of 2014.

National Airlines had an ASAP program for the pilots and an online irregularity reporting system. According to the FAA Principal Maintenance Inspector (PMI), mechanics were a part of the ASAP program, and there was not another program for a mechanic to self-disclose a safety issue, other than simply going directly to management. The Director of Safety said the loadmasters did not have an ASAP program at National Airlines, mainly because “they were not certificated” and it was not clear how to fit them in with the FAA since the program provided certificate protection.¹²² He further said National Airlines had an MOU (memorandum of understanding) for the dispatchers and flight attendants to have ASAP.

Pilots could file irregularity reports to report safety issues, and ASAPs could be filed online with the web based access tool (WBAT), and according to the FAA PMI, National Airlines used WBAT for data collection and analysis. A pilot could also go online on the company intranet and download a copy of the form to fill out. They could also send the company an email, or file a hotline request which was a phone recording. According to the Director of Safety, that option had never been used. He further stated that he had not received any ASAP reports concerning cargo loading issues or load shifts.

According to the National Airlines Weight and Balance Manual (dated October 10, 2012), hiring, training, scheduling and management of loadmasters at National Airlines were the responsibility of the Chief Loadmaster. He was also responsible for the evaluation of loadmasters and “check loadmasters,” and manually scheduled loadmasters using an Excel spreadsheet. The Chief

report safety information that may be critical to identifying potential precursors to accidents. The Federal Aviation Administration (FAA) has determined that identifying these precursors is essential to further reducing the already low accident rate. Under an ASAP, safety issues are resolved through corrective action rather than through punishment or discipline. The ASAP provides for the collection, analysis, and retention of the safety data that is obtained. ASAP safety data, much of which would otherwise be unobtainable, is used to develop corrective actions for identified safety concerns, and to educate the appropriate parties to prevent a reoccurrence of the same type of safety event.

¹¹⁹ Flight Operational Quality Assurance (FOQA) is a voluntary safety program designed to improve aviation safety through the proactive use of flight recorded data. Source: FAA.

¹²⁰ Line Operations Safety Audit. For more information, see FAA Advisory Circular 120-90 “Line Operations Safety Audit.”

¹²¹ According to the Director of Training and Standards, National Airlines conducted flight data gathering and analysis but did not have a formal FOQA program. See Attachment 1 – Interview Summaries.

¹²² See Attachment 1 – Interview Summaries.

Loadmaster told NTSB Staff he wrote the training course, and the content came from various other companies that he “cut and paste from a lot of other manuals.” He also was responsible for training ground operations vendors like National Air Cargo on the airline procedures at National Airlines.

The National Airlines Weight and Balance Manual, Chapter 2 “Loading Information” page 2-1, stated in part:

Given that it is common practice for an air carrier to carry cargo loads that vendors have built up or loaded, an air carrier should have a program that ensures vendors perform cargo buildup and loading in accordance with the air carrier’s procedures. Under such a program, an air carrier should have procedures to:

- 1. Train vendor employees, train a vendor employee to train other vendor employees (train-the-trainer method), or accept the vendor’s training program and procedures provided they meet or exceed the standards established in the air carrier training program and procedures.*
- 2. Designate a trained, qualified, and authorized person to oversee the vendor services to ensure the vendor performs the services in accordance with the air carrier procedures.*
- 3. Audit vendors for compliance with air carrier procedures and training programs under the National Airlines IEP.¹²³*

According to the Chief Loadmaster, National Airlines loadmasters could file “safety reports” online on their intranet that were then sent to the National Airlines safety department. He further stated that he had never had a report about a load shift from a loadmaster.

The National Airlines Director of Training and Standards had been in that position since May of 2012, had been delegated the authority by the Director of Operations to administer the flight operations training program for Pilots, Flight Attendants, and Flight Followers,¹²⁴ and had the final authority as to the content, revision, and distribution of the training program. He told NTSB Staff that his duties at National Airlines included regulatory compliance and effectiveness for pilot, flight follower, and flight attendant training. The National Airlines Director of Training and Standards had no responsibility for loadmaster training, nor did he conduct regular meetings to discuss loadmaster training. He had three full-time staff and an additional six or seven pilots on the B757 and B747-400, each who were simulator instructors and check airmen, and flight follower instructors. National Airlines conducted B747-400 simulator training at Kalitta Air in Ypsilanti, Michigan and United Airlines in Denver, Colorado, and B757 training in Miami.

¹²³ Internal Evaluation Program. For additional information, see AC 12-59A “Air Carrier Internal Evaluation Programs.”

¹²⁴ Source: National Airlines Flight Operations Training Manual, Chapter 2, “Training Program Responsibility and Authority.”

National Airlines did not conduct pilot training under AQP,¹²⁵ nor were they in the process of applying for AQP training. According to the Director of Training and Standards, National Airlines had exited level one SMS development. They were not doing anything specific in the training department nor working with Safety to develop SMS. National Airlines provided their own instructors and check airmen for line and simulator training except in the case of the type rating when they would have to solicit the assistance of the FAA.

Flight follower training for dispatchers was also the responsibility of the National Airlines Director of Training and Standards. National Airlines had ten dispatchers who all had dispatcher certificates. According to the accident dispatcher, National Airlines did not have a jumpseat observation program for dispatchers. There were no familiarization rides available for dispatchers. The accident dispatcher stated that the manager of dispatch had been discussing the idea, and in his (accident dispatcher) opinion, he said it would certainly help him do his job. The National Airline Director of OCC (Operations Control Center) at the time of the accident told NTSB Staff that dispatchers did not do familiarization rides, and he said “we are going to have to do that for the flag operations.”¹²⁶

The National Airlines Director of Training and Standards was not line qualified in the two fleet types on the National Airlines certificate, and stated that he had never conducted enroute or jumpseat line observations as he was “occupied doing other project management.”¹²⁷ He told NTSB Staff that there were a lot of projects going on that needed his attention and there was never a good opportunity based on his workload.

13.0 Relevant Procedures

13.1 Flight Crew Operations Manual (FCOM)

14 CFR 121.141 required the FAA Approved Airplane Flight Manual (AFM) or an equivalent manual be carried on board each aircraft. The National Airlines Flight Crew Operations Manual (FCOM) was prepared by Boeing Commercial Airplanes, Commercial Aviation Services organization. According to the National Airlines FCOM, the manual’s purpose was to:

¹²⁵ Advanced Qualification Program (AQP) is defined by 14 CFR Part 121, Subpart Y and Advisory Circular 120-54, as revised.

¹²⁶ 14 CFR 121.463 (c) stated: “No certificate holder conducting domestic or flag operations may use any person, nor may any person serve, as an aircraft dispatcher unless within the preceding 12 calendar months the aircraft dispatcher has satisfactorily completed operating familiarization consisting of at least 5 hours observing operations under this part, in one of the types of airplanes in each group to be dispatched. This observation shall be made from the flight deck or, for airplanes without an observer seat on the flight deck, from a forward passenger seat with headset or speaker. The requirement of paragraph (a) of this section may be reduced to a minimum of 2 1/2 hours by the substitution of one additional takeoff and landing for an hour of flight. The requirement of this paragraph may be satisfied by observation of 5 hours of simulator training for each airplane group in one of the simulators approved under § 121.407 for the group. However, if the requirement of paragraph (a) is met by the use of a simulator, no reduction in hours is permitted.” A Flag Carrier is defined by the FAA as any scheduled operation conducted by any person operating any turbojet powered airplanes, or airplanes having a passenger-seat configuration of more than 9 passenger seats, excluding each crew member seat, or airplanes having a payload capacity of more than 7,500 lb. at the following locations between any point within the U.S. or any territory or possession of the US respectively, or between any point within the U.S. and any point outside the U.S. or between any point outside the U.S. and another point outside the U.S. See 14 CFR 110.2 – Definitions.

¹²⁷ See Attachment 1 – Interview Summaries.

- *provide operating limitations, procedures, performance, and systems information the flight crew needs to safely and efficiently operate the 747-400 airplane during all anticipated airline operations*
- *serve as a comprehensive reference for use during transition training for the 747-400 airplane*
- *serve as a review guide for use in recurrent training and proficiency checks*
- *provide operational data from the FAA approved airplane flight manual (AFM) to ensure legal requirements are satisfied*
- *establish standardized procedures and practices to enhance Boeing operational philosophy and policy.*¹²⁸

The National Airlines FCOM (dated September 7, 2012 at the time of the accident) was prepared for National Airlines by Boeing, specifically for the airplanes listed in the "Model Identification" section. It contained operational procedures and information which applied only to those airplanes. The manual covered the Boeing delivered configuration of those airplanes. Changes to the delivered configuration were incorporated when covered by contractual revision agreements between the owner/operator and The Boeing Company.

13.2 B747-400 Flight Crew Procedures

13.2.1 Flight Crew Pre-flight of Cargo

According to the National Airlines FCOM, pilots were required to conduct a pre-flight inspection of the airplane prior to each flight. According to the National Airlines FCOM "Exterior Inspection" page NP.21.4:

Before each flight the captain, first officer, or maintenance crew must verify that the airplane is satisfactory for flight.

There was no specific checklist item in the National Airlines FCOM to verify the cargo load and security of the load on the main deck of the B747-400 prior to flight. According to the National Airlines B747-400 check airman who provided B747-400 training to both accident pilots, there was no specific guidance provided to pilots on how to check the cargo during a walk around, but as a technique it was discussed during OE (operating experience). The same check airman stated that pilots would receive a half day of training with the head loadmaster during initial training, and pilots had a CBT (computer based training) module on cargo loading and safety that had a video imbedded in the module. However, another National Airlines B747-400 captain stated he never recalled attending training with any of the loadmasters, was not trained on their procedures, but received a Pelysis CBT (computer based training) module on general cargo strap and tie down conditions. Several National Airlines pilots stated they received no special training on the transport of large military vehicles like MRAPs. In addition, National Airlines did not provide pilots (or loadmasters) with strapping diagrams for any cargo loads, including special loads like MRAPs.

¹²⁸ Source: National Airlines B747-400 FCOM, Preface, page 0.2.1.

The Director of Training and Standards stated that he was not aware of any specialized pilot training or procedural changes regarding floating pallet centerline cargo, military MRAP vehicles, or Cougars. There was no module included in the National Airlines Flight Operations Training Manual (FOTM) for review of a cargo load by the pilots.

A B747-400 Check Airman told NTSB Staff that there were guidelines on how to strap down cargo in the loading manual (Cargo Operations Manual), “but pilots are not evaluated on that information.”¹²⁹ The Check Airman had previously flown with three or four MRAPs loaded on the main deck, along with some other containers. The Check Airman also said the larger vehicles were too large, and they could only fit a few into the main deck. He said “the term MRAP was new to me,” he had heard the term Stryker, but had never heard the term Cougar. He heard them referred to in general terms as military vehicles. There was no specific training or guidance provided to the pilots for operations conducted with MRAPs loaded on the main deck of the B747-400. “Special Loads” were addressed in the Cargo Operations Manual, however according to this B747-400 Check Airman, pilots at National Airlines were not evaluated on the contents of the Cargo Operations Manual.

¹²⁹ See Attachment 1 – Interview Summaries.

13.2.2 Normal Procedures



B747 Normal Checklist

Revision: Revision 2 – 2012-08-31

BEFORE START

<i>Read (F/O)</i>	<i>Respond</i>
Departure Briefing	Complete (C)
Oxygen	Checked, (C, F/O, JS)
Flight Instruments	Checked and set for Departure (C)
Altimeters	IN (hPa), _____ ft, Set (C, F/O)
MCP	V2 _____, HDG _____, ALT _____, (C, F/O)
Takeoff Speeds	V1 _____, VR _____, V2 _____ (C)
Fuel Quantity	_____ planned, _____ Checked (C)
Fuel Control Switches	CUTOFF (C)
Parking Brake	Set (C)
Autobrakes	RTO (C)
Passenger Signs	ON /as desired (C)
Upper Deck Emergency Doors	ARMED (F/O)

BEFORE PUSHBACK

<i>Read (F/O)</i>	<i>Respond</i>
Cabin	Ready (C)
Doors	Closed (C)
Demand Pumps	#4 AUX and AUTO (C)
Beacon	BOTH (C)
Recall	Checked (C)
Trim	_____ units, 0, 0 (C)
Transponder	SET / TCAS OFF (C)

AFTER START

<i>Read (F/O)</i>	<i>Respond</i>
APU	OFF (C)
Nacelle anti-ice	OFF / ON (C)
Aft cargo heat	ON (F/O)
Recall	Checked (C)
CDUs	Checked (C, F/O)
Ground equipment	Clear L (C), Clear R (F/O)

BEFORE TAKEOFF

<i>Read (F/O)</i>	<i>Respond</i>
Flaps	_____ planned, _____ Checked (C)
Flight controls	Checked (C, F/O)
T/O departure review	Complete (PF)
----- Final Items -----	
Cabin	Notified (F/O)
Autothrottles	Armed (F/O)
WXR or TERR	Selected (C, F/O)
Transponder	TA/RA (F/O)
Runway	Rwy _____, Verified (C, F/O)

AFTER TAKEOFF

Checked ALOUD (PM)

Landing gear	Up and Off
Flaps	UP

DESCENT/APPROACH

Checked ALOUD (PM)

Recall	Checked
Autobrakes	Set (OFF)
Landing Data	VREF _____, Minimums _____, Set
Altimeters	IN (HPA), Preset (Set)
WXR or TERR	Selected
Approach Briefing	Complete

LANDING

Checked ALOUD (PM)

Cabin	Notified
Speedbrake	ARMED
Landing gear	DOWN
Flaps	_____

AFTER LANDING

Checked SILENTLY (F/O)

Nacelle anti-ice	As required
Strobe lights	OFF
WXR or TERR	OFF
Flight directors	OFF
Autothrottles	OFF
Speedbrake	DOWN
Flaps	UP
Stab trim	6 units
Transponder	STBY / XPNDR
Autobrakes	OFF
APU	As required

SHUTDOWN

<i>Read (F/O)</i>	<i>Respond</i>
Fuel control switches	CUTOFF (C)
Fuel pumps	OFF (C)
Nacelle anti-ice	OFF (C)
Beacon	OFF (C)
Aft cargo heat	OFF (ON) (F/O)
Transponder	STBY (F/O)
Parking brake	Released (Set) (C)
Demand pumps	OFF (C)
IRS selectors (when satcom not needed)	OFF (C)
Upper Deck Emergency Doors	DISARMED (F/O)

SECURING

<i>Read (F/O)</i>	<i>Respond</i>
Emergency lights	OFF (C)
Packs	OFF (C)
APU, EXT power	OFF (C)
Standby power	OFF (C)
Battery	OFF (C)

FAA APPROVED

BY: _____

DATE: 08-21-12

Figure 6: National Airlines B747-400 Normal Checklist¹³⁰

¹³⁰ Source: National Airlines.

13.2.3 Takeoff Briefing

According to the National Airlines B747-400 FCOM, Normal Procedures, page NP21.23, the pilot executing the takeoff would conduct the takeoff briefing. The takeoff briefing included the following items:

Takeoff Briefing

- *Review of the Aircraft Log and any MEL operational limits*
- *Taxi routing*
- *CRM*
- *Emergencies:*
 - *Rejected takeoff considerations*
 - *Engine out procedure*
 - *Engine out acceleration height and turn procedure*
- *INIT REF page: GR WT*
- *THRUST LIM page: Thrust setting and N1 value confirmation (CDU & Primary EICAS)*
- *TAKEOFF REF page:*
 - *Flap setting, NADP, EOA, THR reduction, V speeds*
 - *V1, V2 verification (PFD)*
- *RTE page 1: Departure runway*
- *RTE page 2: SID*
- *LEGS page:*
 - *Initial HDG or TRK*
 - *Waypoint and altitude constraints (if applicable)*
- *Roll and Pitch modes to be used (FMA)*
- *Initial altitude (FMA)*
- *NAV/RAD PAGE: Nav aids to be used for departure*
- *FIX page: Any additional information to increase situational awareness*
- *VNAV page:*
 - *Clean maneuvering speed below 10,000 ft. versus speed restriction*
 - *Transition altitude*
- *Minimum safe altitude and terrain*
- *WX or TERR selection¹³¹*

13.2.4 Normal Takeoff Profile

According to the recorded information, the pilots of the accident flight planned a normal departure profile for their takeoff from Bagram using full takeoff thrust (108 percent N1) with flaps set to 10 degrees.¹³² According to the National Airlines FCOM, “Normal Procedures – Amplified Procedures” page NP.21.31, when cleared for takeoff, the pilot flying (in the case of the Bagram accident, the captain) would advance the thrust levers to approximately 70% N1 and allow the engines to stabilize, then push the TO/GA¹³³ switch, allowing the autothrottles to

¹³¹ Source: National Airlines B747-400 FCOM, Normal Procedures, page NP21.23.

¹³² For additional information, see Cockpit Voice Recorder Factual Report.

¹³³ Takeoff/go-around.

engage. After takeoff thrust was set, the captain's hand would be on the thrust levers until V₁ in the event of a rejected takeoff. During the takeoff roll, the pilot flying (captain) would maintain light forward pressure on the control column while the pilot monitoring (in the case of the Bagram accident, the first officer) would monitor airspeed indications and call out any abnormal indications. At V_R (rotation speed), the pilot flying (captain) would rotate the airplane toward an initial 15° pitch attitude, and after liftoff, follow the flight director (F/D) commands. The pilot monitoring (first officer) would verify both the altimeter and vertical speed displays show a positive rate of climb and call "POSITIVE CLIMB", and then the pilot flying (captain) would command "GEAR UP."¹³⁴

The National Airlines B747-400 QRH (quick reference handbook), "Maneuvers", page Man.2.1 had the following profile used by B747-400 crews for normal departures:

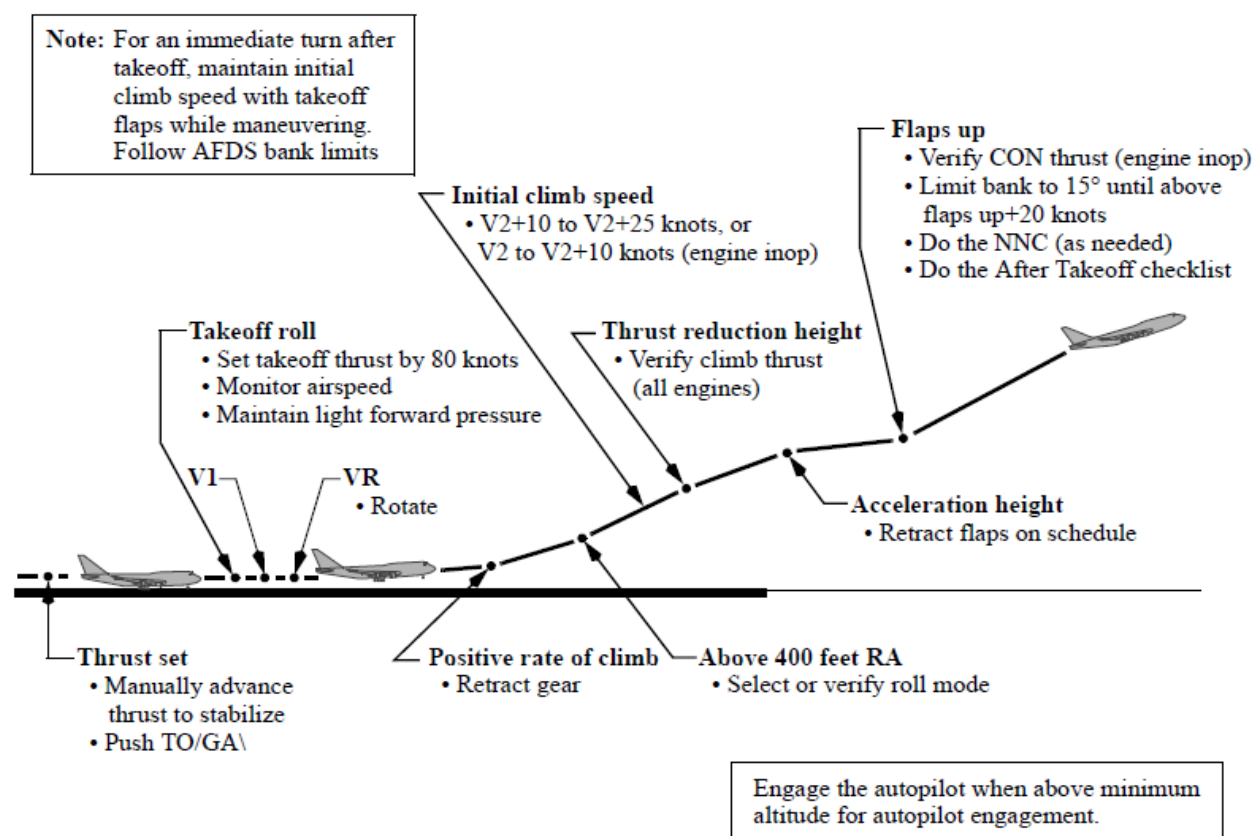

Figure 7: Normal B747 Takeoff Profile¹³⁵

13.2.5 Tactical Departures

The normal takeoff profile used by National Airlines B747-400 pilots was found in the National Airlines B747-400 QRH, "Maneuvers", page Man.2.1. According to witnesses and video evidence, the accident airplane departed Bagram on runway 03, and after rotation was observed

¹³⁴ For additional information, see Attachment 27 – B747 Normal Takeoff Procedures and Attachment 26 – B747 Normal Takeoff Callouts.

¹³⁵ Source: National Airlines B747 QRH, "Maneuvers," page Man.2.1.

entering a steep pitch attitude. Although Bagram was located in an area of potential ground hostilities, and several witnesses told NTSB Staff the airplane could have been conducting a “tactical departure,”¹³⁶ according to National Airlines, B747-400 crews do not have “tactical departure” procedures in their FCOM, nor do they train their pilots on “tactical departures.”¹³⁷

13.2.6 Brake Temp Checklist

According to recorded data, when the crew landed in Bagram, they transitioned from autobrakes to manual braking to slow the airplane. Following the landing in Bagram, the crew received a “BRAKE TEMP” EICAS¹³⁸ message. The crew subsequently ran the BRAKE TEMP non-normal checklist, and delayed departure from Bagram to allow the brakes to cool.

Brake temperatures on the B747-400 were monitored by the Brake Temperature Monitor System (BTMS). If brake cooling was determined from the BTMS, the hottest brake indication 10 to 15 minutes after the airplane had come to a complete stop, or inflight with gear retracted, may be used to determine recommended cooling schedule by entering at the bottom of the Brake Cooling Schedule chart.¹³⁹ An EICAS advisory message, BRAKE TEMP, would appear when any brake registered 5 on the GEAR synoptic display and disappeared as the hottest brake cooled to an indication of 4. According to the National Airlines FCOM, even without an EICAS advisory message, brake cooling was recommended.

The National Airlines B747-400 QRH “BRAKE TEMP” checklist, page 14.9 stated the following:

On the ground:

Refer to the Brake Cooling Schedule in the Advisory Information section of the Performance Inflight chapter for the required cooling time. Minimum cooling time is 70 minutes.

The Recommended Brake Cooling Schedule chart was found in the National Airlines FCOM, page PI.12.7. According to recorded data, after delaying departure on the ground in Bagram, the “BRAKE TEMP” EICAS message extinguished prior to the accident flight taxiing out for departure.

13.2.7 National Airlines Upset Recovery Guidance

According to witnesses and video evidence, the accident flight lifted off runway 03 at Bagram normally and immediately began a pitch up, nose high attitude after departing the runway. Pilots at National Airlines were trained to recover from unusual attitudes based on the guidance outlined in the National Airlines B747-400 FCOM. The National Airlines B747-400 FCOM, Maneuvers Section, page 1.7, defined an unusual attitude as the following:

¹³⁶ NTSB Staff was told by numerous sources in Bagram that “tactical departures” were used by the military, and involved a steep climb attitude after departure to gain altitude and reduce the threats of ground fire.

¹³⁷ For additional information, see Attachment 19 – Tactical Departures.

¹³⁸ Engine Indicating and Crew Alerting System.

¹³⁹ For additional information, see Attachment 24 – B747-400 Brake Temp Checklist.

An Upset can generally be defined as unintentionally exceeding the following conditions:

- *Pitch attitude greater than 25 degrees nose up, or*
- *Pitch attitude greater than 10 degrees nose down, or*
- *Bank angle greater than 45 degrees, or*
- *Within above parameters but flying at airspeeds inappropriate for the conditions*

According to the National Airlines B747 FCOM, the procedures outlined to recover from a nose high attitude represented a “logical progression for recovering the airplane.” The sequence of actions was for guidance only, and represented a series of options to be considered and used depending on the situation. Not all actions may be necessary once recovery was underway. If needed, pitch trim was to be used sparingly. Pilots were guided to use the rudder to aid roll control only if roll control was ineffective and the airplane was not stalled. The techniques for roll recovery assumed that the airplane was not stalled. A stalled condition could exist at any attitude and may be recognized by continuous stick shaker activation accompanied by one or more of the following:

- Buffeting, which could be heavy at times
- Lack of pitch authority and/or roll control
- Inability to arrest descent rate.

If the airplane was stalled, pilots were guided to recover from the stall first by applying full power and applying and maintaining nose down elevator until stall recovery was complete or stick shaker activation ceased.

According to a National Airlines B747 Check Airman, upset recovery was trained in the simulator at National Airlines early in the initial training for the B747 using the guidance outlined in the National Airlines FCOM. Simulator instructors required students to demonstrate about five upset recoveries, and 2-3 of those were typically from a nose high attitude. For the nose high maneuver, National Airlines trained the pilot to first disconnect the auto-thrust and auto-pilot, and apply full power. The pilot would then bring the nose down using up to full elevator, and stabilizer trim could be used as required. If use of the elevator was not enough, the pilot could use bank up to 60 degrees to bring the nose down. Recovery was to wings level with the nose on the horizon. The Check Airman said the engines mounted under the wings had an effect on the pitch, forcing the nose to go up with full power, and that was discussed with the student, as well as reducing thrust which could help bring the nose back down. The initial recovery from the nose high attitude involved pitch and power at the same time, and as necessary use of trim.

Bank was recommended if the input using pitch was not effective. Rudder was not taught for recovery from upset maneuvers. According to the B747 Check Airman, use of the rudder was talked about during training, but the recovery techniques that were taught would be sufficient to return the airplane to normal flight.

According to the B747 Check Airman who provided simulator training to the accident captain, none of the National pilots he trained ever had a problem with upset recovery in his experience, including the accident captain and first officer.¹⁴⁰

The NTSB Operations Group conducted simulator testing in Ypsilanti, Michigan at the Kalitta Airlines Training Facility on June 7, 2013. The Level C B747-400 simulator used in the testing was the same simulator both accident pilots were trained in.¹⁴¹ Nose high recovery events on takeoff were simulated using National Airlines B747-400 procedures for recovery (see Section 13.1.8.1 Nose High Recovery of this Factual Report). However, full-motion simulation of a nose high recovery from a main deck load shift on takeoff was unavailable due to the maximum simulator preset center of gravity (CG) value of 33%.¹⁴²

13.2.7.1 Nose High Recovery

National Airlines B747 crews were provided training on nose high recovery based on the guidance in the National Airlines B747 FCOM. The National Airlines FCOM, Non-normal Maneuvers (QRH),¹⁴³ page Man. 1-8, provided the following guidance for recovery from a nose high attitude:

Nose High Recovery

PF	PM
<ul style="list-style-type: none"> • Recognize and confirm the situation 	
<ul style="list-style-type: none"> • Disengage autopilot and disconnect autothrottle • Apply as much as full nose-down elevator • *Apply appropriate nose-down stabilizer trim • Reduce thrust • *Roll (adjust bank angle) to obtain a nose down pitch rate • Complete the recovery: <ul style="list-style-type: none"> - When approaching the horizon, roll to wings level - Check airspeed and adjust thrust - Establish pitch attitude 	<ul style="list-style-type: none"> • Call out attitude, airspeed and altitude throughout the recovery • Verify all required actions have been completed and call out any omissions

Figure 8: B747 FCOM Nose High Recovery Procedures.

The same section of the National Airlines FCOM provided the following warnings:

¹⁴⁰ See Attachment 1 – Interview Summaries.

¹⁴¹ National Airlines “dry-leased” the Kalitta simulator for training, using National Airlines instructors to train National Airlines pilots. For more information on Level C simulator capabilities, see Advisory Circular 120-40B Airplane Simulator Qualification.

¹⁴² Kalitta simulator engineers could bypass the 33% aft-most CG preset to 52.8%, but the simulator motion was required to be disabled because aerodynamic performance data for the simulator did not support CG values in excess of 33%. See Attachment 23 – Ypsilanti Simulator Work.

¹⁴³ Quick Reference Handbook.

Warning: If the control column does not provide the needed response, stabilizer trim may be necessary. Excessive use of pitch trim may aggravate the condition, or may result in loss of control or in high structural loads.

Warning: Excessive use of pitch trim or rudder may aggravate the condition, or may result in loss of control or in high structural loads.

13.2.8 Boeing Upset Recovery Procedures

Boeing's upset recovery guidance was found in the Boeing B747 Flight Crew Training Manual (FCTM), Section 7 "Maneuvers." Detailed information regarding the nature of upsets, aerodynamic principles, recommended training and other related information was referred to the Airplane Upset Recovery Training Aid.¹⁴⁴

Boeing defined an upset as unintentionally exceeding any of the following conditions:

- Pitch attitude greater than 25° nose up
- Pitch attitude greater than 10° nose down
- Bank angle greater than 45°
- With above parameter but flying at airspeeds inappropriate for the conditions.¹⁴⁵

13.2.9 Upset Recovery Training Aid

The Upset Recovery Training Aid, Section 2.6.3.3, "Nose-Low, Wings-Level Recovery Techniques" page 2.4, provided the following suggested recovery techniques for a pitch attitude unintentionally more than 25 degrees, nose high, and increasing, and airspeed decreasing rapidly.

Start by disengaging the autopilot and autothrottle and recognize and confirm the situation. Next, apply nose down elevator to achieve a nose down pitch rate. This may require as much as full nose down input. If a sustained column force is required to obtain the desired response, consider trimming off some of the control force. However, it may be difficult to know how much trim should be used; therefore, care must be taken to avoid using too much trim. Do not fly the airplane using pitch trim, and stop trimming nose down as the required elevator force lessens. If at this point the pitch rate is not immediately under control, there are several additional techniques that may be tried. The

¹⁴⁴Source:https://www.faa.gov/other_visit/aviation_industry/airline_operators/training/media/AP_UpsetRecovery_Book.pdf. In August 2004, an industry working group was formed to develop the Upset Recovery Training Aid (Revision 1) at the request of the U.S. Department of Transportation, Federal Aviation Administration. The working group consisted, in scope, of both domestic and international organizational representatives from the airline, manufacturer, regulatory, industry trade, and educational segments. The goal of this group was to educate pilots so they have the knowledge and skill to adequately operate their airplanes and prevent upsets in a high altitude environment. This should include the ability to recognize and prevent an impending high altitude problem and increase the likelihood of a successful recovery from a high altitude upset situation should it occur. Revision 2 of the Upset Recovery Training Aid was released October 2008.

¹⁴⁵ Boeing B747-400 FCTM, "Maneuvers", page 7.18.

use of these techniques depends on the circumstances of the situation and the airplane control characteristics.

Pitch may be controlled by rolling the airplane to a bank angle that starts the nose down. The angle of bank should not normally exceed approximately 60 deg. Continuous nose down elevator pressure will keep the wing angle of attack as low as possible, which will make the normal roll controls effective. With airspeed as low as the onset of the stick shaker, or lower, up to full deflection of the ailerons and spoilers can be used. The rolling maneuver changes the pitch rate into a turning maneuver, allowing the pitch to decrease. (Refer to Fig. 33.) In most situations, these techniques should be enough to recover the airplane from the nose-high, wings-level upset.

However, other techniques may also be used to achieve a nose down pitch rate. If altitude permits, flight tests have shown that an effective method for getting a nose down pitch rate is to reduce the power on underwing-mounted engines.

The Upset Recovery Training Aid, Section Sec. 2.5.5.11, “Flight at Extremely Low Airspeeds” included additional guidance for nose high upsets with the following:

“ . . . in some situations for some airplane models, it may be necessary to reduce thrust to prevent the angle of attack from continuing to increase. This usually results in the nose lowering at higher speeds and a milder pitch down. This makes it easier to recover to level flight. If control provided by the ailerons and spoilers is ineffective, rudder input may be required to induce a rolling maneuver for recovery. Only a small amount of rudder input is needed. Too much rudder applied too quickly or held too long may result in loss of lateral and directional control. Caution must be used when applying rudder because of the low-energy situation. (Refer to Sec. 2.5.5.10, “Directional Maneuvering.”)

To complete the recovery, roll to wings level, if necessary, as the nose approaches the horizon. Recover to slightly nose-low attitude to reduce the potential for entering another upset. Check airspeed, and adjust thrust and pitch as necessary.

Nose-high, wings-level recovery:

- *Recognize and confirm the situation.*
- *Disengage autopilot and autothrottle.*
- *Apply as much as full nose down elevator.*
- *Use appropriate techniques:*
 - *Roll to obtain a nose down pitch rate.*
 - *Reduce thrust (underwing-mounted engines).*
- *Complete the recovery:*
 - *Approaching horizon, roll to wings level.*
 - *Check airspeed, adjust thrust.*
 - *Establish pitch attitude*

13.3 Loadmaster Procedures¹⁴⁶

Loadmaster policies and procedures at National Airlines were defined in the National Airlines Cargo Operations Manual and also contained checklists to be used by loadmasters in the performance of their duties. The National Airlines Cargo Operations Manual, page 1-1 stated the following:

These policies and procedures supplement the General Operations Manual and General Maintenance Manual and were developed in accordance with Advisory Circular AC 120-85, IATA Dangerous Goods Regulations, National Airlines Hazardous Materials Manual, Flight Standards Information Management System 8900.1, ATOS Data Collection Tool SAI 1.3.25 Cargo Handling Equipment, Systems and Appliances (AW), ATOS Data Collection Tool SAI 3.1.8 Carriage of Cargo (OP) and all applicable Federal Aviation Regulations (14 CFRs). The procedures and processes contained within this chapter are used to ensure that no aircraft is allowed to take off unless all components of the Cargo Operations program have been executed.

According to the National Airlines Chief Loadmaster and the FAA POI, the Cargo Operations Manual was an FAA “accepted” manual and not an “approved” manual.¹⁴⁷ The POI further stated that accepted manuals “generally had to do with policies and procedures not specific to the OpSpecs.” He said he found National had referenced both the Boeing and Telair manuals in the Cargo Operations Manual. According to the POI, the acceptance process for manuals generally was handled by the appropriate principal inspector, using 8900.1 as a guide.

The Chief Loadmaster at National Airlines told NTSB Staff that a loadmaster was an individual responsible for doing the weight and balance of the airplane during the pre-planning stages of the flight in accordance with manufacturer limitations. Loadmasters inspected cargo and pallets and adhered to what was airworthy, ensured strap and pallet limits were not exceeded and loaded suitable to the aircraft, and ensured the items were secured properly with the provided restraints or supplemental restraints. Loadmasters filled out the weight and balance documents, inspected and properly loaded hazmat material, and were required to notify the captain of the hazmat or dangerous goods locations. Loadmasters also served as ground security coordinators.¹⁴⁸

A National Airlines B747-400 Check Airman stated that “the loadmaster’s have their job...there is very little interaction” between pilots and loadmasters. A B747-400 FO stated that pilots at National Airlines “relied on the loadmasters 100% to make sure the load was done and secured properly.”

According to the National Airlines Chief Loadmaster, loadmasters used a “loadmaster report” to log discrepancies, however there was no requirement prior to the accident for the loadmaster to

¹⁴⁶ For additional information, see Attachment 11 – Loadmaster Procedures.

¹⁴⁷ For further information, see FAA 8900.1 Volume 3, Chapter 32, Section 2 Approval and Acceptance of Manuals and Checklists.

¹⁴⁸ Loadmaster duties and responsibilities in this paragraph were provided by the National Airlines Chief Loadmaster during his NTSB interview. For duties and responsibilities defined in the National Airlines Cargo Operations Manual, see Section 5.1 Load Responsibility of this Factual Report.

complete the loadmaster report every leg, but after the accident, they required it to be completed every leg so they could spot trends in the operations.

13.3.1 Loadmaster Duties

13.3.1.1 Preflight Duties

The National Airlines Weight and Balance Manual, Chapter 2, Section 1, page 2-1 “Aircraft Loading Procedures” stated in part:

The National Airlines Load Supervisor (Loadmaster) or qualified representative is responsible for the acceptance of all cargo planeside, and that all ULDs and pallets are properly identified and tagged in accordance with the COM requirements. The load supervisor is also responsible for verifying the aircraft is loaded and cargo weights checked for accuracy in accordance with the loading manifest provided by the National Airlines OCC. This verification is essential to ensure weight and balance calculations previously performed by National Airlines OCC are valid.

National Airlines loadmasters utilized a checklist (Form CO-9) to perform their duties. The checklist was a laminated paper copy left onboard the airplane, a copy of which could be found in the National Airlines Cargo Operations Manual, page 10-34. Expanded details of each checklist item could be found in the same manual, Section 12, “Loadmaster Checklist (CO-9).”

Loadmasters were responsible for oversight of the loading process and paperwork related to cargo operations at National Airlines. They were also responsible for calculating and completing the weight and balance approved forms OP-1/1B, CO-5, OP-31/31M or approved computerized weight and balance programs. Following the loading process, and prior to takeoff, the loadmaster was required to deliver the completed weight and balance to the captain and first officer.¹⁴⁹ The paperwork delivered to the crew included the zero fuel weight (ZFW), the MAC% (mean aerodynamic chord), the takeoff power setting and the stabilizer trim setting. The pilots would then complete the “PERF DATA” page in the flight management computer (FMC) using that information. The zero fuel weight was entered in the “PERF INIT” page, and takeoff speeds (V-speeds) would be generated by the FMC.¹⁵⁰

Per the National Airlines Cargo Operations Manual (Section 10.4.4, page 10-26), National Airlines loadmasters were required to brief the Pilot in Command regarding the following loads onboard the B747:

- *Hazardous Materials**
- *Live Animals and Perishables*
- *Special Cargo Load*

¹⁴⁹ Source: National Airlines Cargo Operations Manual, Section 10.4.4, page 10-26.

¹⁵⁰ For additional information, see Attachment 23 – Ypsilanti Simulator Work.

**If Hazardous Goods are onboard, the loadmaster will complete a NOTOC¹⁵¹ as part of his/her PIC briefing. If the Dangerous Goods will be transiting other locations additional pages of the NOTOC should be made.*

According to the National Airlines Cargo Operations Manual, Chapter 6 “Special Loads” page 6-1, a special load was defined as follows:

Heavy and Outsized Cargo (BIG) is anything loaded onto an aircraft that is larger or heavier than normal position restrictions would allow. The core reasoning behind limitations is in order to protect the structural integrity and the safe operation of the aircraft. The terms HEAVY and BIG indicate those shipments of abnormal size, shape or weight that require special handling.

The loadmaster was also required by the National Airlines Cargo Operations Manual to check the cargo before departure to ensure all the nets, straps and chains were tightened. According to National Air Cargo personnel, the loadmaster would typically “walk” the main deck with the loading supervisor prior to departure. Any items that were found to need additional restraint were required to be secured before departure. According to the National Airlines Cargo Operations Manual, special attention should be paid to items loaded on top of nets, pipes and small items. All loose items were required to be secured before the aircraft blocked out. The required documents to be onboard the airplane prior to the L1 door closing included the following:

- Cargo Manifest
- AirWay bills
- Permits to Proceed (If applicable)
- Shipper’s Declarations for Dangerous Goods (Hazmat)

The station copies of the flight paperwork were required to be left with the ground handler or station representative. If Dangerous Goods were on the aircraft, a scanned copy or photo of the NOTOC was required to be sent to National Airlines OCC. The following documents should be left behind at the departure station:

- A copy of the Flight Release
- A copy of the Weight and Balance
- A copy of the Load plan if not included on the Weight and Balance

¹⁵¹ Notice to Captain (NOTOC). 49 CFR 175.33 “Shipping paper and notification of pilot-in-command” states in part: “(a) When a hazardous material subject to the provisions of this subchapter is carried in an aircraft, a copy of the shipping paper required by § 175.30(a)(2) must accompany the shipment it covers during transportation aboard the aircraft, and the operator of the aircraft must provide the pilot-in-command with accurate and legible written information as early as practicable before departure of the aircraft . . .”

13.3.1.2 In-flight Duties¹⁵²

According to the National Airlines Cargo Operations Manual, Section 12.5 “After Takeoff,” after departure (above 10,000 Ft and before 16,000 Ft), the loadmaster was required to check any oversize or heavy cargo that had been restrained to the aircraft floor or rails to ensure all restraints were still attached and securing the cargo. The loadmaster was required to notify the crew that he/she was going down stairs and notify them once he/she had returned.

During flight, oversize or heavy cargo that had been restrained to the aircraft floor or rails must be checked to ensure all restraints were still attached and securing the cargo. The loadmaster was required to notify the crew that he/she was going down stairs, and notify them once he/she had returned. According to the National Airlines Cargo Operations Manual, page 10-27, the loadmaster was required to take supplemental oxygen when performing a walk around above 16,000 Ft.¹⁵³

According to the National Airlines Cargo Operations Manual, during flight if the cargo onboard was transiting the next airport, the loadmaster should update the next load plan to reduce time at the next airport. If the loadmaster had received the next cargo weights in advance, they should prepare the next load plan in advance to reduce ground time at the next airport.

On descent (below 16,000 feet) any oversize or heavy cargo that had been restrained to the aircraft floor or rails must be checked to ensure all restraints were still attached and securing the cargo. The loadmaster was required to notify the crew that he/she was going down stairs and notify them once he/she had returned.¹⁵⁴

13.4 Main Deck Access¹⁵⁵

The National Airlines B747 FCOM, “Upper Deck Occupancy (AFM)” page L.10.15 stated:

The total number of persons carried, including crew, shall not exceed 10. Access to the cargo compartment during Taxi, Takeoff, Flight, and Landing is prohibited.

The National Airlines B747 FCOM, “Portable Oxygen” page L10.7 stated:

If portable oxygen is available, the Captain may authorize access to the main cargo deck during flight. Personnel entering main cargo deck during flight will carry a portable oxygen bottle for use if conditions warrant. Proper handling and stowage upon return to upper deck is mandatory.¹⁵⁶

¹⁵² For additional information, see Attachment 11 – Loadmaster Procedures.

¹⁵³ For locations of the portable oxygen bottles on the B747-400, see Attachment 17 – Portable Oxygen.

¹⁵⁴ See Attachment 11 – Loadmaster Procedures.

¹⁵⁵ For additional information, see Attachment 13 – Main Cargo Deck Access.

¹⁵⁶ For location of portable oxygen on the B747-400, see Attachment 17 – Portable Oxygen.

According to the Chief Loadmaster at National Airlines, the procedure to go to the main deck also included informing the flight crew prior to going down. During flight, most loadmasters would try and “stay ahead” by reviewing the next load plan to minimize their ground time. He said if they went down stairs while above 16,000 feet, they were required to take a portable walk around O2 bottle. On descent, out of 16,000 feet, they also went down to check the load. Loadmasters were supposed to do this for every flight, and according to the Chief Loadmaster, every time he was on the airplane they would do it. He could not say if loadmasters were going down to the main deck all the time during flight.

A National Airlines B747-400 Check Airman told NTSB Staff that “no one is allowed on the main deck during flight,” including the loadmaster.¹⁵⁷ The Check Airman also said that during flight there was no personnel allowed on the main deck. As captain and check airman, he said he had never seen a loadmaster go down to the main deck to check the cargo load during flight. He said as far as he knew the loadmasters had never gone down and never notified him that they were going down to the main deck. He said there was no procedure for the loadmaster to inspect the cargo load in flight, and there was no procedure in the pilot’s manuals to allow anyone to inspect the cargo during flight, and that restriction was written in the pilot manuals.

The National Airlines Chief Loadmaster told NTSB Staff he did not coordinate the loadmaster checklist with the flight operations department. He was not aware that there was guidance in the B747-400 FCOM for the pilots restricting all personnel from going down to the main deck during flight.

The FAA POI told NTSB Staff he was not aware of any discrepancy between the National Airlines Cargo Operations Manual and the B747-400 FCOM which prevented personnel on the main deck during flight. When shown the loadmaster checklist in the National Airlines Cargo Operations Manual and the language in the National Airlines FCOM restricting access to the main deck during flight, he said the two manuals did not “interface.”¹⁵⁸ He did not know if National Airlines was aware of that discrepancy in the manuals, and he was also not aware of it. The POI also said to his knowledge, loadmasters were only allowed to go down before and after flight to check the loads, to record discrepancies like broken straps or broken ULDs, and loadmasters had a procedure to log those discrepancies.

14.0 FAA Oversight

14.1 General

National Airlines was a certificated CFR Part 121 airline (certificate number U2RA) authorized by the FAA to conduct supplemental cargo operations.¹⁵⁹ At the time of the accident, the certificate was managed by the East Michigan Flight Standards District Office (FSDO) located in

¹⁵⁷ See Attachment 1 – Interview Summaries.

¹⁵⁸ See Attachment 1 – Interview Summaries.

¹⁵⁹ The FAA regulatory authority to prescribe, revise, and enforce standards is in Title 49, Subtitle VII, Chapter 447, and “Safety Regulation,” Section 44705 “Air Carrier Operating Certificates” empowers the FAA to issue air carrier certificates and to establish minimum safety standards for the operation of the air carrier to whom the certificate is issued.

Belleville, Michigan.¹⁶⁰ Oversight of the National Airlines certificate was the responsibility of the Principal Operations Inspector (POI), the Principal Maintenance Inspector (PMI), and the Principal Avionics Inspector (PAI).

According to the POI with oversight authority at the time of the accident, the FAA used ATOS (Airline Transport Oversight System)¹⁶¹ for their oversight guidance, and described ATOS as “primarily an inclusive closed loop system of surveillance and evaluation and certification of a Part 121 operator. It included evaluation of new programs and certification, doing surveillance and oversight, and a risk management system to mitigate risks at an operator for items identified as high risk.”¹⁶² The POI also used the guidance of FAA Order 8900.1 to conduct oversight activities.

FAA Order 8900.1, Chapter 1 “Handbook Organization, Use, and Revision”, Section 1-1, stated in part:

This order directs the activities of aviation safety inspectors (ASI) responsible for the certification, technical administration, and surveillance of air carriers, certain other air operators conducting operations in accordance with the appropriate part of Title 14 of the Code of Federal Regulations (14 CFR), certificated airmen, and other aviation activities. This order also provides direction for tasks related to aircraft accidents and incidents, investigations and compliance, the aviation safety program, administrative areas, and miscellaneous tasks not related to a specific regulation. In addition, it contains regional and district office requirements for the support of ASIs responsible for those activities.

The POI told NTSB Staff that his responsibilities included oversight of the operations of the air carrier, including all operational aspects of National Airlines, training, operation of the aircraft, and “basically complete oversight on the operations side.” The POI, PMI and PAI all had oversight authority of the airline, and they met quarterly to talk about the risk assessments associated with National Airlines, and each of those positions answered to the Front Line Manager (FLM). The frequency of visits to National Airlines was driven by ATOS surveillance requirements.

¹⁶⁰ FAA oversight of the National Airlines 14 CFR Part 121 certificate was moved from the Ypsilanti, Michigan Flight Standards District Office (FSDO) to the South Florida Certificate Management Office (CMO) during the summer of 2013.

¹⁶¹ According to the FAA, ATOS is based on the explicit policy of the FAA, which states: “The FAA will pursue a regulatory policy, which recognizes the obligation of the air carrier to maintain the highest possible degree of safety.” ATOS implements FAA policy by providing safety controls (i.e., regulations and their application) of business organizations and individuals that fall under FAA regulations. Under ATOS, the FAA’s primary responsibilities are: (1) to verify that an air carrier is capable of operating safely and complies with the regulations and standards prescribed by the Administrator before issuing an air carrier operating certificate and before approving or accepting air carrier programs; (2) to re-verify that an air carrier continues to meet regulatory requirements when environmental changes occur by conducting periodic reviews; and (3) to continually validate the performance of an air carrier’s approved and accepted programs for the purpose of continued operational safety. Source: FAA 8900.1 CHG 81, Section 1 “Air Transportation Oversight System Doctrine.”

¹⁶² See Attachment 1 – Interview Summaries.

The POI characterized National Airline's safety culture as "satisfactory," and said National Airlines had just completed level 2 of SMS implementation before they moved their offices to south Florida. The PMI characterized his communications with National as "open communications with management, the Director of Maintenance and the Director of Quality Control." The Director of Operations at National Airlines was also open to communications and would come to the FAA with questions, they worked well together, and National had a "good compliance attitude."

The PMI told NTSB Staff that he did have surveillance responsibilities for National Airlines mechanics. When asked how he would provide surveillance of mechanics overseas if he was not there, he said "you answered your own question." National did very little contract maintenance except for heavy maintenance, and their line maintenance was done by National Airlines mechanics since they flew with the airplanes. The heavy checks on the airplanes were performed in XIAM (China) where Northwest/Delta Airlines conducted their heavy checks.

14.2 Loadmaster Oversight

The National Airlines Chief Loadmaster, when asked if the POI was responsible for overseeing the loadmasters or the PMI, said "we straddle a line," since part of a loadmaster's work was with the loading system, which was on the maintenance side, and "they sat on the POI side since they worked with operations." The PMI said loadmasters were considered part of the operations side at National Airlines, and the airline described that based on who the loadmasters answered to in their organizational chart since, ultimately the loadmasters and loading supervisors answered to the Director of Operations. There was no guidance in ATOS that dealt with loadmasters, and the PMI "had nothing to do with the cargo operations manual at National." When asked if he had oversight of the loadmasters, the POI said he "it fell under both specialties, but there was no guidance in the 8900."¹⁶³

The POI did not recall if loadmasters were identified in the Federal Aviation Regulations, and he wanted to see loadmaster training at National Airlines, but "there was no loadmaster training guidance or 8900 guidance."¹⁶⁴ The POI worked with the chief loadmaster with checklist construction so the loadmasters had some sort of guidance.

The POI considered loadmasters as "an extension of the captain, being given the authority to load the airplane together and loading of hazmat."¹⁶⁵ The loadmaster would bring the load sheet to the captain and they would both sign for the weight and balance. According to the POI, National Airlines trained loadmasters and gave them a card saying they were a loadmaster, but the position was not certified according to the FAA. The POI stated that the title of "check loadmaster" was something National Airlines defined to monitor and evaluate the loadmasters, similar to how check airmen evaluated pilots; however it was an internal program to the company, and "they had no FAA function."

¹⁶³ See Attachment 1 – Interview Summaries.

¹⁶⁴ See Attachment 1 – Interview Summaires.

¹⁶⁵ See Attachment 1 – Interview Summaries.

When asked if loadmasters were considered “other operations personnel” as defined by 121.400 (a),¹⁶⁶ the POI told NTSB Staff that he considered them as “other operations personnel, the same as when an outside mechanic would touch the airplane and you would want to ensure he had a certificate in their pocket before you allowed them to work on an airplane, but they are not certificated.” Review of loadmasters was based on other carrier’s “best practices” since there was no guidance, and the POI said “that was part of the problem”. He contacted the Kalitta group to get an idea of how they trained their loadmasters, and he would work with National Airlines on their training. Training hours for a loadmaster were defined in the National Airlines Cargo Operations manual, however there was no regulation defining the number of hours needed for loadmaster training. At the time of the accident, the FAA had just completed a safety action team (SAT) allowed under ATOS for risk mitigation.¹⁶⁷ A NASIP (National Aviation Safety Inspection Program) had also run an assessment, and according to the PMI, the primary problem with National Airlines was that “they were having problems training and hiring loadmasters, and they (FAA) worked with the operator for changes.”¹⁶⁸

There were no duty time or rest requirements for loadmasters defined in the CFRs. The POI said National Airlines did have a fatigue risk management program, and the flight crews were included, but to his knowledge the loadmasters were not, and he was told the loadmasters were scheduled with the flight crew. The POI had no knowledge that loadmasters were being scheduled up to 30 hours, and he said loadmasters could get rest in the airplane in the bunk rooms, though he believed they typically did not use them.¹⁶⁹

When asked how he would know loadmasters were performing their duties in accordance with the Cargo Operations Manual when National Airlines operated overseas and into Afghanistan, the POI said “I would not.” He also said he had not gotten any reports from the check loadmasters about their inspections of other loadmasters. When asked if the FAA should certify loadmasters, the POI said “that was way above my pay grade,” but that there should be guidance, and they should be certified.¹⁷⁰

14.3 Enroute and Ramp Inspections

According to the FAA, inspectors should conduct routine surveillance (“performance assessments”) to confirm that an air carrier’s operating systems produce intended results in

¹⁶⁶ 14 CFR 121.400(a) stated, in part: “This subpart prescribes the requirements applicable to each certificate holder for establishing and maintaining a training program for crewmembers, aircraft dispatchers, and other operations personnel, and for the approval and use of training devices in the conduct of the program.”

¹⁶⁷ According to the National Airlines Director of Safety, in 2011 it was recommended the airline conduct a LOSA audit of their operations following an SAT audit, but the company opted not to do one. See Attachment 1 – Interview Summaries.

¹⁶⁸ In addition, personnel from the Department of Defense (DOD) Commercial Airlift Division conducted a biennial survey of the National Air Cargo Group, Inc., on March 26-29, 2012. According to the results of the survey, National Air Cargo, Inc. met the DOD Commercial Air Transportation Quality and Safety Requirements for continued participation in the DOD Air Transportation Program.

¹⁶⁹ As previously mentioned in this Factual Report, 14 CFR 121.523 stated that each certificate holder “shall also provide adequate sleeping quarters on the airplane whenever an airman is scheduled to be aloft as a flight crewmember for more than 12 hours during any 24 consecutive hours.” Loadmasters are not certificated flight crewmembers or airmen.

¹⁷⁰ See Attachment 1 – Interview Summaries.

accordance with the policies and procedures detailed in FAA Order 8900.1. The normal planning process was to develop a risk-based data collection plan. Specific information about the conduct of enroute inspections was also detailed in FAA Order 8900.1.¹⁷¹

FAA 8900.1 CHG 270, Volume 6 “Surveillance” Chapter 2, Section 9 “Cockpit En Route Inspections” stated in part:

The primary objective of cockpit en route inspections is for an inspector to observe and evaluate the in-flight operations of a certificate holder within the total operational environment of the air transportation system. En route inspections are one of the Federal Aviation Administration’s (FAA) most effective methods of accomplishing its air transportation surveillance objectives and responsibilities. These inspections provide the FAA with an opportunity to assess elements of the aviation system that are both internal and external to an operator.

Elements of the aviation system that were internal to the operator and could be observed during en route inspections were items such as the following:¹⁷²

- Crewmembers,
- Operator manuals and checklists,
- Use of minimum equipment lists (MEL) and Configuration Deviation Lists (CDL),
- Operational control functions (dispatch, flight following, flight locating),
- Use of checklists, approved procedures, and safe operating practices,
- Crew coordination/cockpit resource management,
- Cabin safety,
- Aircraft condition and servicing, and
- Training program effectiveness.

Elements of the aviation system that were external to the operator and could be observed during enroute inspections are items such as the following:

- Airport/heliport surface areas,
- Ramp/gate activities,
- Airport construction and condition,
- Aircraft movements,
- Air traffic control (ATC) and airway facilities,
- ATC and airspace procedures,
- Instrument approach procedures (IAP),
- Standard Instrument Departures (SID),
- Standard Terminal Arrival Routes (STAR),
- Navigational aids, and
- Communications.

¹⁷¹ For additional information, see Attachment 33 - 8900.1 Enroute Inspections.

¹⁷² Source: FAA 8900.1 CHG 270, Volume 6 “Surveillance” Chapter 2, Section 9 “Cockpit En Route Inspections.”

FAA inspectors conducted ATOS performance assessments (PAs) to confirm an air carrier's operating systems produced intended results, including mitigation or control of hazards and associated risks. ATOS used time-based PAs to detect latent, systemic failures that may occur due to subtle environmental changes. PA schedules were also adjustable based on known risks or safety priorities.

Depending on the element's criticality, assessments were automatically scheduled to occur every six months (high criticality), one year (medium criticality), or three years (low criticality). The evaluation of Airman Duties/Flight Deck Procedures was a high criticality item and thus automatically scheduled for evaluation every six months.

According to the POI, the FAA had attempted to conduct enroute inspections of National Airlines flights into and out of Afghanistan, but the State Department would not allow them to travel into theater.¹⁷³ The POI had attempted to get jumpseat authority into Afghanistan, but they could never jumpseat on them since they could not do line checks overseas, and the State Department prohibited them from traveling into Afghanistan.

According to the POI, for line checks of new captains and two year observations of check airmen, National Airlines would bring a B747-400 to the US, and they would fly it to 2-3 destinations while the pilots would rotate in the pilot seats getting line checks and observations. According to the FAA, this was the only time the B747-400 would come to the US for observations since they (FAA) could not do line checks overseas.¹⁷⁴ According to the FAA, the flights were flown empty, and there was no opportunity to survey the loading of cargo, strapping of cargo, or loadmaster operations and procedures.

According to the FAA, there had not been any attempts to survey the National Airlines cargo or flight operations in Dubai (or Afghanistan) since September 2012. The National Airlines Director of Safety also told NTSB Staff that he did not think the FAA had been out looking at their operation enough.¹⁷⁵

NTSB Staff reviewed PTRS data for National Airlines, provided by the FAA, and could not find a recorded surveillance event conducted by the FAA on National Airlines for an enroute cockpit inspection of the B747-400 (PTRS reference codes 1624, 3629, 5629, 7624, 8624).¹⁷⁶

14.4 Department of Defense Restrictions¹⁷⁷

According to the FAA, there is no specific process defined for an inspector conducting surveillance activities into Afghanistan. When traveling to a foreign country, the FAA inspector conducting the enroute surveillance must comply with both the State Department requirements and the requirements of the country to which they are traveling. The FAA Office for Policy, International Affairs & Environment had a web site that had all the travel requirements that the

¹⁷³ For further information, see Attachment 8– FAA Responses.

¹⁷⁴ See Attachment 14 – NAL B747-400 Flights.

¹⁷⁵ See Attachment 1 – Interview Summaries.

¹⁷⁶ Attachment 37 – FAA PTRS Data.

¹⁷⁷ For additional information, see Attachment 8 – FAA Responses.

FAA inspector must comply with and provided contacts, web links for important information provided by other agencies, and some of the forms required for their travel.¹⁷⁸

According to the FAA, normally the agency did not clear ATOS enroute inspections through the State Department. The State Department was notified by the FAA through the country clearance process. A country clearance request was required to be sent and a response received prior to each international trip. The request described the purpose of the intended trip and the itinerary of the traveler, and the State Department made a determination to approve or disapprove the trip via the country clearance request. The reason the FAA contacted the State Department directly in the regards to conducting enroute inspections on National Airlines flights into Afghanistan was because the trips involved travel into a war zone. Additionally, this request was made before a country clearance request was submitted.

Following a request by the National Airlines POI to perform an enroute on National Airlines into Afghanistan, the Economic/Civil Aviation officer for Afghanistan at the State Department advised the FAA that there was a travel restriction for all government personnel to Afghanistan. The State Department told the FAA that FAA ASI travel to Afghanistan was not recommended “given the deteriorating security situation there.”¹⁷⁹ The Economic/Civil Aviation officer stated that travel into Afghanistan would have to be “extenuating circumstances” and involve “full State Department security (armored vehicles travel etc.) in country which is now problematic and costly” for travel at the airports the FAA requested travel to.

The POI stated the FAA could not require an operator to provide them with an airplane to conduct an enroute inspection since the FAA could not impose cost on an operator. He also did not know why the State Department had objections to their travel into Afghanistan if they were just turning around and leaving on the same flight.

14.5 Cargo Operations Oversight¹⁸⁰

According to the PMI, under ATOS the FAA had high criticality items required to be surveyed every six months and medium criticality items that were required every 12 months and low criticality items that were required every 36 months. Cargo loading equipment and continuous analysis surveillance were high criticality items. The PMI said he had attempted to observe the loading process, but had only seen National Airline’s B747-400 loaded once when he went to Dubai in 2012 for five days. He was able to observe the loading process on a more regular basis with the DC8’s when they were coming through the YIP airport. In Dubai for the one time he observed National Airlines, they loaded only general items and military items. He could not remember if the load was going into Afghanistan, and told NTSB Staff he was not allowed to go to Afghanistan because the State Department would not issue them visas to travel to Afghanistan, and they could only observe the aircraft in Dubai. One FAA cabin safety inspector out of Minnesota was able to do an enroute cabin inspection, and he said he heard that “there was

¹⁷⁸ The referenced web site is: https://employees.faa.gov/org/staffoffices/apl/international_travel/guidelines/.

¹⁷⁹ See Attachment 8 – FAA Responses.

¹⁸⁰ For additional information on FAA cargo oversight, see Attachment 32 - 8900.1 CHG 116 Cargo Inspections. For additional information on quoted elements of this section, see Attachment 1 – Interview Summaries.

some fallout from it.”¹⁸¹ When asked how he would survey an operation overseas like the National Airlines B747-400, he said that “you would just go to DXB [Dubai, UAE] and see what you see,” and the one time he went to Dubai, he observed the 757 when it arrived and left.¹⁸²

In September of 2012, the PMI and POI observed cargo equipment movement in Dubai, but did not observe any of the pallet build ups since, according to the PMI, “that was the POI’s responsibility.”¹⁸³ They would look at loads to see if there was anything obviously wrong with them, and the PMI did not observe any center loaded pallets since all were secured to the side rails. The PMI never had an opportunity to observe the straps. According to the PMI, September 2012 was the last time the PMI had observed the National Airlines B747-400 operation. He had attempted to go over there since, but was told the FAA did not have the funding. NTSB Staff reviewed PTRS data for National Airlines, provided by the FAA, and could not find a recorded surveillance event conducted by the FAA on National Airlines related to cargo loading of the B747-400 (PTRS reference codes 1638, 3623, 5623, 8638).¹⁸⁴

Surveillance items that were not accomplished by the POI and PMI in accordance with ATOS guidance were listed as “non-resourced.” Those “non-resourced” items would roll over into the next month, and POI and PMI would again try and accomplish them. In ATOS, it would show “non-resourced” items that were carried over, but neither the POI or PMI knew how long those items could continue not being accomplished, and neither knew if there was a threshold of how many “non-resourced” could be accumulated before the operation had to be observed. The PMI said that regarding the surveillance, there was no way to “farm it out”, and the only surveillance they could do was “on paper.” He said for items like cargo loading surveillance that would drive them to go over there and look at them, if they could not get over there (Dubai) to accomplish those items, they would indicate that in their ACAT (Acquisition Categories), which was their basis for doing their risk assessment for the airline, and would elevate the risk for further assessment. The PMI said the FLM did not have to respond to “non-resourced items,” but would acknowledge the increased risk level noted in ACAT, and that would be placed in the comment field. There was no specific threshold when the risk indications got elevated, and according to the POI and PMI, they would keep increasing the risk assessment even though they were never accomplishing the surveillance.

The PMI told NTSB Staff that, to his knowledge, ATOS did address cargo loading equipment but did not address cargo securing. A ramp inspection on National Airlines was performed once in Dubai for the B747-400 in September 2012. According to the PMI, the FAA had tried “a half dozen times”¹⁸⁵ to do ramp inspections on a National Airlines B747-400, but “the trip would always change or cancel and the airplane would not be there.” He did not consider National’s operation as a “work around” for oversight, and “their operation in Dubai was the reason they bought the airplanes, to fly DoD missions.”

¹⁸¹ See Attachment 1 – Interview Summaries.

¹⁸² See Attachment 1 – Interview Summaires.

¹⁸³ See Attachment 1 – Interview Summaries.

¹⁸⁴ See Attachment 37 – FAA PTRS Data.

¹⁸⁵ See Attachment 1 – Interview Summaries.

14.6 Risk Management

The POI told NTSB Staff that he was not aware that National was strapping the heavy vehicles to the seat tracks until after the accident and he saw pictures of the strapping. He learned National Airlines was carrying heavy rolling palletized stock in early 2013, and was not aware of it in 2012. The FAA was not informed by National Airlines that the airline was carrying large, heavy military vehicles center-loaded on the B747-400 on floating pallets, and the FAA only learned about the cargo National Airlines was transporting when, according to the POI, “someone in the office (FSDO) said Kalitta and others were hauling them.”

The FAA was not aware of any risk analysis done by National Airlines for the carriage of 18 ton military vehicles, and the FAA was not notified by National Airlines that they were carrying multiple MRAPs prior to the accident. The PMI told NTSB Staff it was out of his area of expertise if the carriage of those vehicles would constitute a change in the operations requiring a risk analysis to be conducted, but it in his opinion “it would need to be addressed.”¹⁸⁶

FAA Order 8900.1 CHG 210, Volume 10 “Air Transportation Oversight System” Chapter 3, Section 1 “Risk Management Process” stated in part:

10-338 INTRODUCTION TO THE RISK MANAGEMENT PROCESS (RMP). *The RMP provides Certificate Management Teams (CMT) and Certificate Project Teams (CPT) with procedures to manage hazards and their associated risks. The RMP provides the CMT/CPT with a means to document and track hazards, and to oversee and evaluate the disposition of associated risks. This process has five major steps, including:*

- *Hazard identification (identify hazards and consequences),*
- *Risk analysis (analyze hazards and identify risks),*
- *Risk assessment (consolidate and prioritize risks),*
- *Decision making (develop an action plan), and*
- *Validation of control (evaluate results for further action).¹⁸⁷*

FAA inspectors were guided by 8900.1 to use the RMP to address any hazard identified by any CMT member that the principal inspector (PI) or certification project manager (CPM) decided was significant enough to justify analysis and tracking. Systemic hazards were often good candidates for this process.¹⁸⁸ The POI told NTSB Staff that he did not learn that National Airlines was carrying heavy rolling palletized stock until early 2013. The FAA did not conduct a risk analysis when it was discovered that National Airlines was hauling heavy military vehicles like MRAPs because, according to the POI, “the manual seemed sufficient,” and “if they were following their manual there should not be an issue.”¹⁸⁹

Subsequent to the accident, the FAA conducted a review of National Airlines manuals since the FAA was unsure the guidance loadmasters were referencing in the Boeing and Telair manuals. National Airlines extracted both Boeing and Telair guidance and put it into their Cargo

¹⁸⁶ See Attachment 1 – Interview Summaries.

¹⁸⁷ For further information, see Attachment 34 - 8900.1 Risk Management.

¹⁸⁸ Source: FAA Order 8900.1 CHG 210, Volume 10 “Air Transportation Oversight System” Chapter 3, Section 1 “Risk Management Process.”

¹⁸⁹ See Attachment 1 – Interview Summaries.

Operations manual for “one stop shopping rather than having to references separate manuals.”¹⁹⁰ The review of National Airlines that began with the Michigan FSDO office was not completed before management of the National Airlines certificate was transferred to the South Florida CMO.

At the time of the accident, the FAA had just completed a safety action team (SAT), which ATOS allowed for risk mitigation. A NASIP (National Aviation Safety Inspection Program) had also run an assessment of National Airlines, and the primary problem identified with National Airlines, according to the FAA, was that they were having problems training and hiring loadmasters.¹⁹¹

14.7 Advisory Circular 120-85: Air Cargo Operations

This AC provided air carriers with recommended procedures for managing air carrier cargo operations. It provided recommendations about what items should be included in an air carrier cargo operations system.¹⁹²

14.8 FAA Guidance Post-Accident

SAFO (Safety Alert for Operators) 13005 (May 17, 2013)

This SAFO advised operators of the potential safety impact of carrying and restraining heavy vehicle special cargo loads. The purpose was to reemphasize current policy and guidance concerning: weight and balance control procedures, cargo loading procedures, loading schedules and loading instructions.

SAFO 13008 (August 20, 2013)

This SAFO served to recommend tie-down procedures for restraint of special cargo loads.¹⁹³

F. LIST OF ATTACHMENTS

- Attachment 1 – Interview Summaries
- Attachment 2 – Crew Information
- Attachment 3 – Crew Training Records
- Attachment 4 – Dispatch Release
- Attachment 5 – ATC
- Attachment 6 – General Declaration
- Attachment 7 – Operations Specifications
- Attachment 8 – FAA Responses
- Attachment 9 – Flight Crew Experience with MRAPs
- Attachment 10 – Flight Crew Procedures
- Attachment 11 – Loadmaster Procedures

¹⁹⁰ Statement made by the POI. See Attachment 1 – Interview Summaries.

¹⁹¹ See Attachment 1 – Interview Summaries.

¹⁹² See Attachment 35 - AC 120-85.

¹⁹³ For full text of the SAFO, see Attachment 25 – SAFO 13008.

Attachment 12 – Loadmaster Training
Attachment 13 – Main Cargo Deck Access
Attachment 14 – NAL B747-400 Flights
Attachment 15 – NAL Normal Checklist
Attachment 16 – National Air Cargo Stryker Prep
Attachment 17 – Portable Oxygen
Attachment 18 – Stabilizer Trim Checklist
Attachment 19 – Tactical Departures
Attachment 20 – Weather
Attachment 21 – Weight and Balance
Attachment 22 – Witness Statements
Attachment 23 – Ypsilanti Simulator Work
Attachment 24 – B747 Brake Temp Checklist
Attachment 25 – SAFO 13008
Attachment 26 – B747 Normal Takeoff Callouts
Attachment 27 – B747 Normal Takeoff Procedures
Attachment 28 – Bagram Airfield Diagram
Attachment 29 – Bastion Loading Demo Photos
Attachment 30 – Bastion Loading
Attachment 31 – Charts
Attachment 32 – 8900.1 CHG 116 Cargo Inspections
Attachment 33 – 8900.1 Enroute Inspections
Attachment 34 – 8900.1 Risk Management
Attachment 35 – AC 120 85
Attachment 36 – NAC ULD Inspections Process
Attachment 37 – FAA PTRS Data
Attachment 38 – Party Forms
Attachment 39 – Organizational Charts

Submitted by:

Captain David Lawrence
NTSB