

Attachment 10

To Operations Group Factual Report

DCA15FA085

Spoiler - Speed Brake Lever

Spoiler/Speed Brake

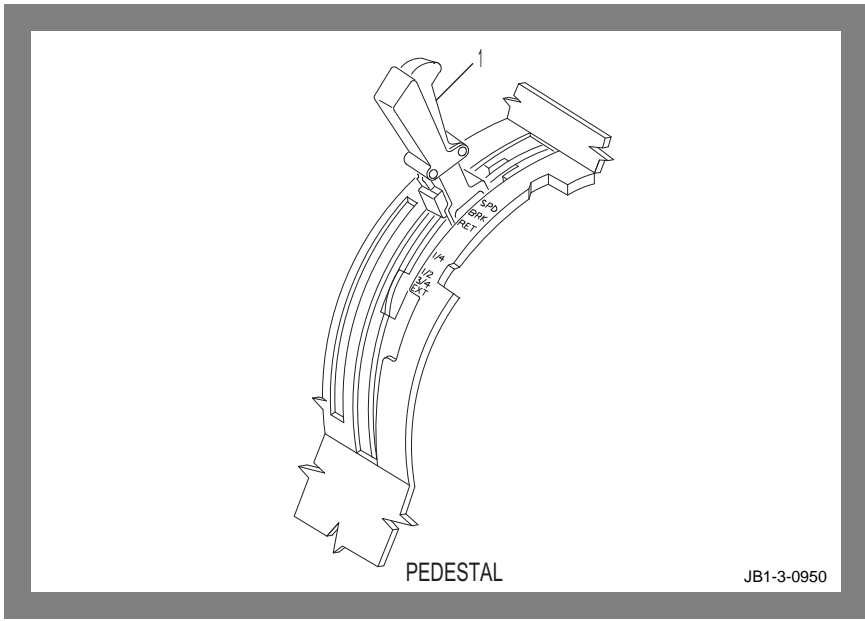

1 SPD BRK Lever

Manual - In flight, the lever is used to control the flight spoilers to act as speed brakes when squeezed and pulled aft. Positions available are 1/4, 1/2, 3/4, or EXT.

On the ground, the lever deploys all spoilers when pulled up-aft-up. The lever is also used to release spoiler actuation when pushed down and allowed to move forward to RET.

Automatic - When armed (squeezed and pulled up), a red placard labeled ARM can be seen on both sides of the lever.

When armed prior to takeoff and a rejected takeoff is initiated (nosewheel on ground and throttles retarded), the flight and ground spoilers automatically extend to 60° upon actuation of reverse thrust.

When armed prior to landing, the flight and ground spoilers automatically extend to 60° upon main wheel spinup or nose wheel compression (groundshift).

When the spoiler lever moves aft, the flight and ground spoilers are fully extended to 60°.