

DOCKET NO. SA-516

APPENDIX 14

NATIONAL TRANSPORTATION SAFETY BOARD
WASHINGTON, DC

INTERVIEW TRANSCRIPT
JAMES THOMAS STANES
NOVEMBER 20, 1996
(47 pages)

1
2
3
4
5
6
7
8
9
10
11
12
13
14
15
16
17
18
19
20
21
22
23
24
25

BEFORE THE
UNITED STATES OF AMERICA
NATIONAL TRANSPORTATION SAFETY BOARD

- - - - - x
In the Matter of: :
TWA FLIGHT 800 :
INTERVIEW OF :
JAMES THOMAS STANES :
- - - - - x

The above-entitled matter came on for interview, pursuant to Notice, before NORM WIEMEYER, NTSB Official, at JFK International Airport, Jamaica, NY, on Wednesday, November 20, 1996 at 1:00 p.m.

1 APPEARANCES:

2 TERRY STACEY, TWA

3 LU LIEBER, FBI, NY

4 STEPHEN KIAPACH, FAA

5 CHARLES HALE, IAM

6 DENNIS SANTIAGO, IAM

7 LOU BURNS, AIRLINE PILOTS ASSOCIATION

8 SCOTT E. METCALF, FBI, NY

9

10

11

12

13

14

15

16

17

18

19

20

21

22

23

24

25

I N D E X

1
2
3
4
5
6
7
8
9
10
11
12
13
14
15
16
17
18
19
20
21
22
23
24
25

WITNESS

PAGE

JAMES THOMAS STANES

4

- - -

E X H I B I T S

IDENTIFIED

RECEIVED

None

- - -

P R O C E E D I N G S

1
2
3
4
5
6
7
8
9
10
11
12
13
14
15
16
17
18
19
20
21
22
23
24
25

MR. STARNES: Okay. First name, James Thomas Starnes.

MR. WIEMEYER: And give us an address for you, please.

MR. STANES: Okay. 204 Glenside Trail, Sparta, New Jersey.

MR. WIEMEYER: And the Zip Code?

MR. STANES: 07871.

MR. WIEMEYER: Okay. And a telephone number.

MR. STANES: 201-729-5491.

MR. WIEMEYER: Okay. When we get the transcript back from this interview, we will get it to you for review so that you can make sure that there wasn't any typographical errors or any misunderstandings -- will be using some technical terms, probably that the Court Reporter may not be totally familiar with.

MR. STANES: Okay.

MR. WIEMEYER: How long have you been employed with TWA?

MR. STANES: I've been with TWA 28 years.

MR. WIEMEYER: And what is your position with TWA?

MR. STANES: As a flight engineer, presently on 747 aircraft. I've been qualified on 707, 727, Lockheed 1011 and now 747 as flight engineer.

1 MR. WIEMEYER: Okay. And what certificates and
2 ratings do you hold?

3 MR. STANES: I hold a -- instrument, flight
4 instructor and flight engineer ratings.

5 MR. WIEMEYER: Does your flight engineer certificate
6 cover just turbo jet or --

7 MR. STANES: Yes, just turbo jet.

8 MR. WIEMEYER: Okay. And what is your present
9 capacity with the company?

10 MR. STANES: Presently, I fly -- as a 747 engineer.
11 I'm also a line instructor and a check airman for flight -- on
12 747.

13 MR. WIEMEYER: What specialized training did you get
14 in order to become a check airman and instructor?

15 MR. STANES: I went out to training in St. Louis at
16 our training center there for several days of training for
17 check airman, and I was given a check by the company and then
18 by the FAA.

19 MR. WIEMEYER: Okay. Would you describe your walk-
20 around on the aircraft in general terms?

21 MR. STANES: Okay.

22 MR. WIEMEYER: What you're looking for.

23 MR. STANES: General terms, when I first arrive in
24 the cockpit, one of the very first things, we, of course, do a
25 safety check and one of the first things we check are the

1 fluids -- oil, hydraulics and oxygen. Those are the items that
2 might cause a delay. So we look at those first. If they need
3 to be serviced, then we contact maintenance, and from there
4 proceed to do a cockpit pre-flight and then walk through the
5 cabin and we go on the outside, do a walk-around on the
6 outside.

7 MR. WIEMEYER: Okay. Specifically, on the outside of
8 the aircraft, are there any -- other than general condition and
9 security, are there specific items that you're required to take
10 a look at?

11 MR. STANES: Of course, we check tires, wheels,
12 brakes, all inspection panels for being in place, check the --
13 disc for the oxygen system -- disc for the -- system on all
14 four engines and the APU.

15 MR. WIEMEYER: Specific areas with regards to the
16 fuel system, do you check for allowed drippage or leakage or --

17 MR. STANES: We make note if there's anything leaking
18 or dripping out of any tank or any system. If we note leakage,
19 we will make note of that.

20 MR. WIEMEYER: What do you do with that information,
21 say you did spot some fuel --

22 MR. STANES: The first thing we would do would be
23 contact maintenance immediately and advise them of what we
24 found, and then my next step would be to contact the captain,
25 if it's going to be a delay or a problem.

1 MR. WIEMEYER: Okay. At what point and how do you
2 become aware of what the fuel load is going to be and how it's
3 going to be distributed?

4 MR. STANES: Normally, I would know that information
5 before I left the hanger. If it's an international flight, all
6 cockpit crew members would go down to dispatch. We'd review
7 the flight plan and talk it over with the captain, review the
8 fuel load, see if he was happy with that or if he wanted to add
9 fuel. So that's where I first learn what the fuel load will be
10 is in dispatch at the hanger.

11 MR. WIEMEYER: Okay. At some point after that,
12 before you depart, do you get any documents in the cockpit that
13 verify your fuel?

14 MR. STANES: The next thing we would get -- I would
15 normally carry a copy of the flight plan with me to the
16 aircraft. That would have the information on it. Next, I
17 would get a copy of the load slip, weight slip that would come
18 -- usually generated, teletyped right up to the cockpit. That
19 would also have the fuel -- that should agree with the flight
20 plan.

21 MR. WIEMEYER: Okay. Do you calculate -- balance
22 yourself or is that done by the company --

23 MR. STANES: That's done by the company, given to us
24 over the radio.

25 MR. WIEMEYER: Okay. Do you have any verification

1 procedures on that?

2 MR. STANES: If there's something -- if we have a
3 doubt or something, we can't settle a discrepancy, we could
4 actually run a weight and balance ourselves. We have a weight
5 and balance computer -- in the cockpit, but, normally, it's all
6 given to us by radio, load control.

7 MR. WIEMEYER: Okay. I want to kind of skip around
8 here a little bit.

9 MR. STANES: Okay.

10 MR. WIEMEYER: And let's go off the record for just a
11 second.

12 (Brief recess.)

13 MR. WIEMEYER: Okay. We can go back on.

14 If en route either you discovered or one of the other
15 flight crew members discovered a fluctuating fuel flow gauge,
16 what would you actually do?

17 MR. STANES: If I were first to discover it, I'd
18 ^{point it} ~~phone~~ out to the captain that we've got -- something is wrong
19 back here, fuel gauge is fluctuating. I'm sure if someone else
20 spotted it first, they would point it out to me.

21 And, next, we would see if we could find a reason for
22 it. If it's fluctuating -- circuit breaker problem, if it's
23 gone to zero, possibly a circuit breaker problem.

24 MR. WIEMEYER: I'm talking about fuel flow.

25 MR. STANES: Fuel flow.

1 MR. WIEMEYER: Yes. If you could, go into a little
2 bit of detail with regards to how you would trouble shoot
3 fluctuating fuel flow.

4 MR. STANES: If you see fluctuating fuel, the first
5 thing you want to look to make sure the boost pumps are on to
6 the engine, that for some reason they haven't been shut off and
7 the cross -- valve closed. So that means the first thing you
8 look for is to make sure there's pump pressure for the engine.

9 MR. WIEMEYER: Okay. Well, where would you go from
10 there?

11 MR. STANES: And the next -- next, probably go to our
12 manual. That would be the first -- procedure would be -- that
13 would be the very first thing, to make sure we got fuel
14 positive pressure to the -- to the engine.

15 MR. WIEMEYER: In a 747 installation fuel flow, would
16 you expect to see some correlation on the other engine
17 instruments if there was, in fact, a fluctuating fuel flow?

18 MR. STANES: Oh, absolutely. If it definitely is a
19 fuel-flow problem, your other engines, your EPR, your EGT, all
20 of the other instruments are going to also make some movement.
21 If the engine is losing power, spinning down because of loss of
22 fuel, we're going to see it on the other instruments also.

23 MR. WIEMEYER: Okay. In the normal course of your
24 duties in that regard, if you had that situation arise where
25 you had a fluctuating fuel-flow gauge, in your trouble shooting

1 and analysis of that would there be a discussion in the cockpit
2 between your cockpit crew members in that regard?

3 MR. STANES: Oh, absolutely. Yes, there would.

4 MR. WIEMEYER: Can you think of a situation -- again,
5 under normal circumstances -- where you had that, where you
6 would not discuss it with the captain and first officer?

7 MR. STANES: Not really. Any problem at all, it's a
8 team effort, so you're going to discuss it with them.

9 Now, if you look down and you see fluctuation there,
10 the very first thing you're probably going to do is reach back
11 and make sure your pumps are on, the switches are on, and then
12 you might turn and say something. Probably your first action,
13 you're going to make sure that everything is where it should
14 be. If that continues, then you're going to -- it'll be a team
15 effort to discuss it with each other.

16 MR. WIEMEYER: Okay. Again, I said I was going to
17 jump around, so -- as these things come into my mind.

18 In preparation for departure, how do you become aware
19 of any servicing that's done on the engine, and specifically
20 oil service to the engine?

21 MR. STANES: Oil is normally -- When the fuel slip is
22 brought to the cockpit, either by a mechanic or the fueler,
23 normally, the oil that's been added, there's a block for each
24 engine at the bottom. It's normally written in on the fuel
25 slip.

1 Now, in some cases, if maintenance has serviced the
2 engine with oil before the fuelers have gotten there, they'll
3 bring a separate piece of paper to the cockpit and the oil add
4 would be -- again, there'd be a block for each engine, and the
5 amount that was added to each engine would be written there.

6 If you don't have it in one place or the other, our
7 job is to contact maintenance and tell them that we do not have
8 a verification of oil add. If the slip isn't there, sometimes
9 they'll give it to you over the radio. Say, "Oh, yeah. We
10 have it here," and they'll tell me what amount was added to
11 each engine, and then we put that in the log book, but,
12 normally, it shows up at the bottom of the fuel slip.

13 MR. WIEMEYER: Okay. I can't think of anything else
14 right now.

15 Terry.

16 MR. STACEY: Okay. Terry Stacey with TWA.

17 Jim, who then would put the oil add on the M-180, on
18 the bottom of the M-180?

19 MR. STANES: If it's -- if it's not on the 180, we
20 find out from maintenance, and we don't have the separate slip
21 of paper. We write it in the log book. We've not been
22 instructed to write it on the fuel slip itself --

23 MR. STACEY: I understand, but how often would you
24 say that the oil add is on your M-180?

25 MR. STANES: I'd guess probably 75 percent of the

1 time it's on the 180.

2 MR. STACEY: Okay. And do you know who puts it on
3 the 180 then? Not a crew member, but --

4 MR. STANES: It would be maintenance. It would be
5 maintenance -- that did the actual oil add, be either him or a
6 supervisor would write it on.

7 MR. STACEY: Okay. At what point -- So you go to the
8 hanger and you go over the flight plan and you check what the -
9 - the load slip -- the total fuel load, but then how do you
10 become aware of the distribution of the fuel?

11 MR. STANES: That's, of course, from what we observe
12 on the flight engineer panel, and then when the fuel slip is
13 brought to the cockpit and it lists each tank, what they fueled
14 it to, and we verify with what we see, that's when we actually
15 see what's distributed in each tank.

16 MR. STACEY: Do you verify that?

17 MR. STANES: Oh, yes, we check it against our own
18 gauges --

19 MR. STACEY: I understand, but do you verify the fuel
20 distribution from M-180 and the gauges against another
21 document?

22 MR. STANES: That's in our manual that we can check
23 each tank, what it should be for that load. If it's going to
24 be a 200,000-pound fuel load, we turn to that page, it will
25 point out what each tank should be serviced to.

1 MR. STACEY: Okay. What would be your action or what
2 would you expect the action of the flight engineer that you're
3 training or checking to do if a tank was loaded with less fuel
4 than called for in the distribution?

5 MR. STANES: We're told to find out the discrepancy,
6 talk with maintenance to find out why or what has happened
7 here, why it was fueled or under-fueled different than what is
8 called for.

9 MR. STACEY: Okay. Have you ever had occasion in
10 your training or in your career to have reserve tanks on a 747
11 fueled to less than capacity?

12 MR. STANES: Depending on the fuel load, yes. As the
13 fuel load comes up, might be a case where you would have maybe
14 1,000 pounds in each reserve, but as the fuel rises, it
15 determines whether you're supposed to have full tanks in the
16 reserves to be full or it could be a case where you have no
17 fuel at all in the reserves. You have a very light fuel load.

18 MR. STACEY: Okay. But in your experience, normally
19 what do you experience with that?

20 MR. STANES: Normally, you see the reserves -- 1 and
21 4 reserves completely full is a normal situation. Probably 98
22 percent of the time, I see that.

23 MR. STACEY: Would you bring that -- if 1 and 4 -- If
24 the distribution called for 1 and 4 reserves to be fueled and
25 it was, say, 1,000 pounds or 1,200 pounds low, would you advise

1 the captain?

2 MR. STANES: Absolutely, if it wasn't what it was
3 supposed to be.

4 MR. STACEY: Okay. Do you occasionally, in a walk-
5 around, observe any type of liquid dripping from the airplane
6 or on you --

7 MR. STANES: Occasionally. It's not unusual to see a
8 small amount of hydraulic fluid dripping from the -- there's
9 little weep holes in the tank vent system and a few drops -- if
10 it's overfilled -- will be dropping from there.

11 It's quite common when airplanes come in from a long
12 flight for water to be dripping from it, just condensation. So
13 you're always getting hit by water. It's very unusual to see
14 fuel dripping. If fuel is dripping, there's a problem
15 somewhere.

16 MR. STACEY: Okay. I always have a follow-up
17 question -- but that's all I have --

18 MR. KIAPACH: Hi. Steve Kiapach from the FAA.

19 Terry had mentioned about the fuels of -- reserves
20 being somewhat lower -- called out, would you have another
21 sheet stating the exact amount in those tanks before
22 departure --

23 MR. STANES: You mean the first sheet arrived and it
24 showed there were less than supposed to be or if I discovered
25 it?

1 MR. KIAPACH: Well -- the original sheet was supposed
2 to be full --

3 MR. STANES: Okay.

4 MR. KIAPACH: -- and for some reason they're not full
5 -- another sheet showing the exact amount in those tanks?

6 MR. STANES: Yes, we should have a separate sheet --
7 showing exactly what was actually there.

8 MR. KIAPACH: Okay. I have no other questions.
9 Thank you very much.

10 MR. STANES: Okay.

11 MR. BURNS: Jim, Lou Burns, ALPA. I have no
12 questions at this time.

13 MR. HALE: Charlie Hale with the IAM.

14 You said you call back when you find a maintenance
15 problem, if no maintenance personnel are around. Now, do you
16 contact maintenance directly or is that through some other way?

17 MR. STANES: It depends. If we find the problem as
18 we're walking around outside and if there's a mechanic nearby,
19 that's my quickest source and usually I would walk over to him
20 and he has a radio, he would call inside. If not, if no one's
21 around, then I would run up to the cockpit and call the
22 frequency for maintenance.

23 MR. HALE: And it goes to the TWA tower and they get
24 in contact with them --

25 MR. STANES: Depends on the station. Here at

1 Kennedy, we can speak directly to the maintenance on frequency
2 131.17. Smaller stations, maintenance does not have their own
3 frequency, then I'll have to contact FIC from the tower and
4 they would contact maintenance.

5 MR. HALE: You stated that sometimes when you walk
6 around the aircraft you could possibly feel a few drops from a
7 vent system, a tank vent system. Exactly what tank vent system
8 were you referring to?

9 MR. STANES: Well, in that I was referring to -- for
10 instance the hydraulic system, the four hydraulic tanks, the
11 little ~~reps~~. It's not unusual for a little fluid to drip out
12 of the ~~reps~~, out of the vent system on those.

13 MR. HALE: On a transatlantic flight, the reserve
14 tanks, you would presume them for a normal condition would be
15 to what level?

16 MR. STANES: They would be full on an international
17 flight, the fuel load would be -- in nearly all cases -- be
18 completely full -- reserves.

19 MR. HALE: And you wouldn't deviate from that
20 procedure.

21 MR. STANES: Well, the book says we can take off with
22 them empty, but normally it's not done -- So I can't think of
23 any reason to really depart, unless maybe the valve for dumping
24 that tank was inoperative or something, there was some
25 particular reason for it, then that might be the case, but --

1 MR. HALE: Thank you very much.

2 MR. METCALF: I'm Scott Metcalf from the FBI.

3 Which -- Just for my own education here, which tank
4 is the --

5 MR. STANES: Number 2 tank --

6 MR. METCALF: Number 2.

7 Okay. And when you guys fire up the engines for taxi
8 out, you're taxi-ing out for take-of, which engines are
9 normally running at that time? Is there like a standard
10 procedure, like you got 1 and 2 running and 3 running and 4
11 later or is it 1, 2 and 4 or how does it --

12 MR. STANES: Normally -- procedure, I'd say normal
13 operation is all four engines are started at the gate or
14 engines 1, 2 and 4 are started, and number 3 -- if it's going
15 to be a long taxi, our procedure calls that we can start number
16 3 later, and if it's going to be an extensive taxi, we can even
17 shut down number 2 engine and taxi out on 1 and 4.

18 MR. METCALF: Let's say for instance you're on a
19 flight and you're cleared to climb -- say you're in the range
20 say 13,000, 18,000 and ATC calls up and gives you a climb, and
21 the pilot flying will call for climb power, who sets the climb
22 power on the aircraft?

23 MR. STANES: The --

24 MR. METCALF: Okay. So -- and how does that work? I
25 mean, you're sitting side saddle at your panel, do you not have

1 a chair that slides up or --

2 MR. STANES: Yes, our chair's on a track. It'll move
3 forward and out to -- back and forth and swivel, so it's just a
4 matter of lifting a level, sliding up to --

5 MR. METCALF: Okay. And in climb situations like in
6 that range -- say 13,000 to 18,000 -- I mean, is it common to
7 transfer fuel, not transfer, but cross feed.

8 MR. STANES: Not normally. On a 747 100 series, you
9 wouldn't start a cross feed until -- tanks run in -- between
10 20,000 and 23,000 pounds, so you could be just about reaching
11 it about say 17,000 or 18,000.

12 MR. METCALF: Okay. What would be a reason maybe to
13 go in a cross feed, you know, your opinion? Let's say you're
14 somewhere in the 13,000 range and you're in a -- you know,
15 you're up there and you're cross feeding. And let's say the
16 fuel load we're talking about -- the same fuel load as Flight
17 800 had.

18 MR. STANES: Normally, you're not coming up on cross
19 feed quite that soon, but if you are --

20 MR. WIEMEYER: Yes.

21 MR. STACEY: Jim, wouldn't know what fuel load 800
22 had.

23 MR. METCALF: Oh, okay. Well, just a common --

24 MR. STACEY: I can, with a follow-up question -- With
25 a follow-up question, we can clarify that.

1 MR. METCALF: Okay. We'll do that later then.

2 And one last question. As many years as you've been
3 around the airport, you know -- flying, what would you -- how
4 would you describe a critical fuel leak if you came upon one
5 doing the walk-around?

6 MR. STANES: Well, any leak at all of fuel is not
7 normal.

8 MR. METCALF: Okay.

9 MR. STANES: So I'd consider that critical.

10 MR. METCALF: All right. Thanks a lot.

11 MR. WIEMEYER: I've got a couple of follow-ups here.

12 One, as a matter of policy, does the captain have an
13 option to depart with less fuel than the dispatch release calls
14 for?

15 MR. STANES: Not normally, as a normal policy. I
16 mean, he -- if he determined from the dispatcher that there was
17 a legitimate reason --

18 MR. WIEMEYER: Can he, of his own volition, request
19 more fuel than the dispatch release calls for, and is there a
20 limit to that before he has to recontact dispatch and have the
21 release changed?

22 MR. STANES: If he wants more fuel, normally, he
23 would contact dispatch and say, "I want this amount of fuel."
24 That's his option.

25 MR. WIEMEYER: Okay. Is there any amount of fuel

1 that he can request over the dispatch release fuel before he
2 has to contact the dispatcher? Can he ask for 3,000 more or
3 some amount?

4 MR. STANES: Normally, any amount that he asks for,
5 he discusses it with dispatch first.

6 MR. WIEMEYER: Okay. Make sure I understand. He
7 cannot -- It's not a crew option to leave with less fuel than
8 what the release calls for.

9 MR. STANES: Right.

10 MR. WIEMEYER: That's all I have in that area.

11 Let's go back to the follow-ups --

12 MR. STACEY: Jim, if you departed with 24,600 pounds
13 in 1 and 4 -- okay? -- that is the fuel at the gate -- at the
14 ramp, can you give us an idea how long after takeoff it would
15 be before you --

16 MR. STANES: If you departed with that amount -- say
17 a normal burn for takeoff, up to 30,000 pounds in an hour --
18 I'd have to figure it out mathematically, but maybe 70 or 1,000
19 feet or so you're going to need to start cross feeding. You're
20 going to have 1 and 4 coming down towards 20,000 pounds in each
21 tank and you need to get a cross feed before you go below
22 20,000 pounds in 1 and 4.

23 MR. STACEY: Okay. Is it -- What is the policy of
24 when you go on cross feed?

25 MR. STANES: Okay. Our policy when we're -- in this

1 case, of a 100, if tanks 1 and 4 are between 20,000 and 23,000
2 pounds, first, we advise the captain, "Okay. Time to start our
3 cross feed." And at that time, of course, the captain will
4 turn and observe what we did, and so we're going to open all of
5 our cross feed valves. Normally 2 and 3 are closed, so we're
6 going to open 2 and 3 and then shut off the pumps in tanks 1
7 and 4, and tanks 2 and 3 are going to supply all four engines.

8 MR. STACEY: Okay. I want to try and nail down the
9 -- Okay. Let me ask you this: At what point between 20,000
10 and 23,000 pounds would you teach someone to go on cross feed?

11 MR. STANES: I might recommend to them when they're
12 somewhere around 21,500, just for ease of computation. They've
13 got 21,500 in tanks 1 and 4. That's a good time to do it,
14 because 1 and 4, plus their reserve, it's 25,000, so when you
15 come off cross feed, then, you're going to have 25,000 pounds
16 across the board, so you're going to have a total of 100,000
17 pounds, but I mention to them if it's a critical time in
18 flight, if they're still below 10,000 feet, it's more important
19 to be looking outside than cross feeding fuel on your panel.
20 If there's some other problem going on in the airplane -- maybe
21 a generator problem, electrical -- I mention, you'll take care
22 of this first. Don't stick with 21,500, but everything's
23 normal why then 21,500 is a good time to do it.

24 MR. STACEY: Okay. So the most that -- with 24,600
25 an average, you would have to then burn only 3,000 pounds out

1 of 1 and 4 to be at 21,500.

2 MR. STANES: That's right.

3 MR. STACEY: So on 3,000 pounds he has to burn --

4 MR. STANES: Each one. So that's a total of 12,000.

5 MR. STACEY: Correct.

6 Okay. And how much fuel is a 747 engine burning at
7 climb power or take-off power per engine?

8 MR. STANES: Per engine, it's about -- it would be
9 about 10,000, 10,500, approximately.

10 MR. STACEY: Okay. So 10,000 pounds per engine,
11 10,000 pounds per hour, so it would take -- burn 3,000 pounds,
12 20 minutes, at the most.

13 MR. STANES: Yes.

14 MR. STACEY: Okay. So our policy, basically, then is
15 -- is to wait -- anytime -- at above 10,000 pounds -- 10,000
16 feet.

17 MR. STANES: Yes, we recommend that.

18 MR. STACEY: Okay.

19 MR. STANES: Even though you're approaching the
20 limit.

21 MR. STACEY: So with 24,600 pounds for take-off in 1
22 and 4, would you expect that soon after 10,000 feet that the
23 guy would be on cross feed?

24 MR. STANES: Normally, pretty soon after he's going
25 to be coming up on his limit --

1 MR. STACEY: Okay. That's all.

2 MR. WIEMEYER: Anybody else got any follow-up?

3 (Brief recess.)

4 MR. WIEMEYER: The M-180 copy that you have is from
5 Flight 800 on the 17th, and is this a document that you are
6 familiar with?

7 MR. STANES: Yes.

8 MR. WIEMEYER: Is this supplied to you on board the
9 aircraft prior to departure?

10 MR. STANES: Yes, it is.

11 MR. WIEMEYER: Okay. In looking at that document, do
12 you see anything on that document which specifically attracts
13 your attention as being different or odd from what you're used
14 to seeing?

15 MR. STANES: Looks like a normal 180 -- that we get
16 before departure each time. There's little or no -- no --
17 fuel. 1 and 4 are full. It's distributed, and it's within
18 limits. We're allowed a 650 gallon tolerance. This appears to
19 be about 355 gallons. So it's well within tolerance. It looks
20 -- looks like a normal 180.

21 MR. WIEMEYER: Okay. If you received this on a
22 flight that you were -- would you -- would it be acceptable to
23 you?

24 MR. STANES: Yes.

25 MR. WIEMEYER: Okay. Based on what you see in -- on

1 that 180, if you would then go down to the drawing that we have
2 supplied of the fuel panel, which is a drawing that was done
3 for us by NASA after examining the recovered panel from Flight
4 800. The heavy dark type is the numbers that they derived in
5 their examination, and the position of the valves and switches
6 is as they found them during that examination.

7 First off, do you have any questions with regards to
8 that panel?

9 MR. STANES: Well, it appears that -- from reading --
10 it looks like there's 81.3 fuel indicated in the center tank --
11 am I reading that correctly --

12 MR. WIEMEYER: Well, we want to go by the heavy
13 numbers --

14 MR. STANES: The heavy numbers.

15 MR. WIEMEYER: -- not by what -- What's actually on
16 the gauges is not what they --

17 MR. STANES: What they found. Okay.

18 MR. WIEMEYER: -- what they found. That's just a --

19 MR. STANES: Oh, okay. Very good.

20 MR. WIEMEYER: I think it's a drawing out of a text
21 book, actually --

22 MR. STANES: Okay.

23 MR. WIEMEYER: -- that they made some changes to.

24 MR. STANES: I find it unusual that the number 1 --
25 valve would be open. Although that's something that could have

1 happened on impact or -- it's certainly not a normal --

2 MR. WIEMEYER: We know from the history of flight on
3 Flight 800 that at the time that the event occurred, they were
4 in a climb and been cleared from 13,000 to 15,000 feet, and
5 they were about 22 minutes into the flight.

6 MR. STACEY: Not that far.

7 MR. WIEMEYER: It wasn't that far?

8 MR. STACEY: Ten-and-a-half minutes --

9 MR. WIEMEYER: Oh, that's right. I'm sorry -- They
10 were about 10-1/2 minutes into the flight.

11 So given the M-180, what you see there, how would you
12 expect to see that fuel panel set up at that point in time?

13 This was the second step climb -- and it was all due
14 to crossing traffic. So they had just departed 13,000 --
15 13,700 and moved to 15,000.

16 MR. STANES: Normally, you would see the panel with
17 the boost -- on in tanks 1, 2, 3 and 4 and cross -- valve 2 and
18 3 closed -- off for the center tank, would be the normal
19 configuration at this point.

20 MR. WIEMEYER: Would you mind just drawing that in
21 there in red where you'd expect stuff to be?

22 MR. STANES: Okay. So -- You want me to just write,
23 "on," or --

24 MR. WIEMEYER: Just an arrow upwards if you want it
25 on --

1 MR. STANES: Okay.

2 MR. WIEMEYER: -- or an arrow down and just an arrow
3 where you think it should -- the stuff should be, the way you
4 would set up the panel.

5 (Whereupon, Mr. Stanes drew on the document.)

6 MR. WIEMEYER: Okay. And, again, based on the M-180
7 -- and if you can't -- if this is not a feasible question,
8 please tell me -- the fuel load on M-180, at that point in the
9 flight, what fuel would you expect to see in each of those
10 tanks? And if you want to write that down right next to the
11 fuel load on the M-180, that would be fine. Where would you
12 expect the fuel quantities to be in each of those tanks at that
13 point in the flight?

14 (Whereupon, Mr. Stanes wrote the numbers on the
15 document.)

16 MR. STANES: Okay. I've written in --

17 MR. WIEMEYER: Okay. Looking back at -- and if you
18 need another drawing, let me know.

19 MR. STANES: Okay.

20 MR. WIEMEYER: I've got plenty of copies here.

21 Looking back at the panel again, under what
22 circumstances would you -- if any -- would you expect to see a
23 panel set up in the fashion that it shows --

24 MR. STANES: This particular case, I can't see any
25 reason why the boost pumps would be in this configuration.

1 Again, I would tend to think this must be something to do with
2 impact. I can't imagine in a normal situation purposely
3 setting them up like this.

4 MR. WIEMEYER: Okay.

5 MR. STANES: At this point.

6 MR. WIEMEYER: -- strictly with the reserve tanks --
7 with the number 1, the -- valve being in the closed position,
8 number 4 being in the open position, under what circumstances
9 would you have -- disregarding everything else on the panel --
10 would you have those two tanks set up in that fashion?

11 MR. STANES: With one open and one closed? I can't
12 think of any reason that you would set them up like that, and
13 the only time you would open the reserves 1 and 4 would be when
14 you're starting your descent and you're dumping the 1 and 4
15 reserves into 1 and 4 or if you've gotten down to a fuel load
16 of less than 5,000 pounds in tanks 1 and 4, then that calls for
17 you to dump the reserves also.

18 MR. WIEMEYER: Okay.

19 MR. STANES: But at this point -- early point of
20 flight, climbing out, I can't think of any reason you would
21 ever open the 1 and 4 reserves.

22 MR. WIEMEYER: Okay. Based on the information that
23 we've given you with regards to how long the flight had been
24 airborne and your calculation of the fuel burn, would you
25 expect them to have been cross feeding at that point in the

1 flight, given the circumstances that we related to you?

2 MR. STANES: Quite possible. Possibly at just about
3 this point, you're down to about 21,000 in 1 and 4, so he's
4 probably thinking about going on cross speed about this time,
5 and it would certainly be within range to do it between 20,000
6 and 23,000 pounds.

7 MR. WIEMEYER: As a check engineer, if you were
8 giving a training flight or a check flight to an engineer, how
9 would you personally handle it with regards to seeing when and
10 if and how he went about this type of function?

11 MR. STANES: It depends on how far along the student
12 is in his training, but if he's at the panel and I'm observing
13 him, as long as he's doing things according to the book, I say
14 very little and let him do the procedure. Now, if he does a
15 procedure that is not according to the book, something non-
16 standard, say we're above 23,000 pounds in 1 and 4 and he
17 decides to go on cross feed, then I'm going to stop him.
18 Anytime -- If he deviates from our standard procedure, I would
19 stop him. Otherwise, so long as he's operating within standard
20 procedure, then I'll let him go.

21 MR. WIEMEYER: Okay. Thank you. That's all I have.

22 MR. STACEY: Okay. Jim, you take the other -- the
23 new copy of the fuel panel --

24 MR. STANES: Okay.

25 MR. STACEY: -- and I note on the M-180 that you have

1 put the numbers in in which you estimated you would have 21,000
2 in 1 and 4 mains. Correct?

3 MR. STANES: Correct. Um-hum.

4 MR. STACEY: Okay. So if the flight engineer's
5 practice was to go on cross feed when he got to 23,000 in 1 and
6 4, would you expect him to be on cross feed at this point in
7 the flight, 13,500 or earlier -- between 10,000 and 13,500?

8 MR. STANES: Yes. At this point -- if he's above
9 10,000 and -- some of the guys, as soon as it reaches 23,000
10 pounds in 1 and 4, they want to get busy cross feeding. So
11 it's not -- you know -- certainly -- it's within reason if he's
12 below 23,000, he could be on cross feed.

13 MR. STACEY: Okay. Norm, do you mind if he labels
14 this one panel --

15 MR. STANES: "Before cross feed"?

16 MR. STACEY: -- "before cross feed"?

17 MR. WIEMEYER: Sure. That'd be fine, "before cross
18 feed."

19 MR. STACEY: All right. "Before cross feed." And
20 the other panel, "On cross feed," and draw -- indicate the
21 valve and pump positions.

22 (Whereupon, Mr. Stanes wrote on the document.)

23 MR. STACEY: Okay. So on cross feed all cross-feed
24 valves would be open --

25 MR. STANES: Yes.

1 MR. STACEY: -- and the 1 and 4 reserve-tank valves
2 would be closed, is that correct?

3 MR. STANES: That's right. Um-hum.

4 MR. STACEY: And boost pumps in tanks 1 and 4 would
5 be off, is that correct?

6 MR. STANES: That's correct.

7 MR. STACEY: With the override jettison pumps off in
8 the center-wing tank.

9 MR. STANES: That's correct.

10 MR. STACEY: Right?

11 MR. STANES: That's right.

12 MR. STACEY: And the scavenge pump?

13 MR. STANES: It would be off also. If it's got --
14 set it at 300 pounds in there. According to this it may be
15 600. It could possible be on, but more than likely it's going
16 to be in the off position.

17 MR. STACEY: Would you normally expect to see that
18 fuel taken out of there with just the residual fuel in there
19 after he's completed cross feed or at any time during the cross
20 feed --

21 MR. STANES: Normally, you would see it -- that pump
22 come on after cross feed or towards the end of cross feed. If
23 he's balancing tanks or something, you might see that -- come
24 on normally then, but under most circumstances, it would always
25 be in the off position.

1 MR. STACEY: Okay. Is it a practice to take that
2 fuel out of there? Again, let's assume that we started with
3 300 pounds of fuel in the center wing tank. Would it be a
4 practice to take that fuel out of there with a scavenge pump or
5 leave it in?

6 MR. STANES: Normal practice -- I see guys that I
7 observe do it about 50/50. Some guys, if there's a little bit
8 of fuel in there, they want to get it all out to zero, and some
9 guys it's 300 pounds indicated, it's not enough to worry about.
10 They just leave it there.

11 MR. STACEY: At what point in flight do you normally
12 observe them taking it out of there in those cases, those that
13 do?

14 MR. STANES: The ones that do, they normally would
15 take it out at the end of the cross-feed procedure when they're
16 balancing tanks and going back, tank the engine.

17 MR. STACEY: Okay. With a light fuel load in --
18 Would you consider this a relatively light fuel load?

19 MR. STANES: In comparison to the long -- Telaviv,
20 the Rome flight, I'd consider this a light load.

21 MR. STACEY: Have you seen occasion where you're
22 getting close to the limits or where -- close to the limits
23 where that would go on cross feed before 10,000 feet?

24 MR. STANES: I don't normally see it happen, because
25 we've always trained -- taught the guys not to cross feed.

1 Wait 'til you're at least -- 10,000 feet, even though you're
2 getting close to the limits. Spend that -- few minutes up to
3 10,000 feet looking outside and spend as little time inside the
4 cockpit as possible.

5 MR. STACEY: But then you're expecting right at
6 10,000 feet -- above 10,000 feet, then, to initiate cross feed,
7 is that correct?

8 MR. STANES: Yes, I would expect them to, yes.

9 MR. STACEY: Would the -- yes, the -- On the fuel
10 panel that says, "on cross feed," you have -- where you've
11 indicated numbers on the M-180, will you also indicate the
12 numbers on the M-180 that you would expect to see in the
13 respective tanks had he gone on cross feed?

14 MR. WIEMEYER: Let's go off the record for just one
15 second.

16 (Brief recess.)

17 MR. STANES: I said unless at 23,000, if this
18 fellow's anxious to get started cross feeding, maybe he went on
19 at that time, but, otherwise, this is what I would normally
20 expect to see at that point.

21 MR. WIEMEYER: -- down at the earliest practical time
22 that he may have gone on cross feed --

23 MR. STACEY: Let's put this M-180, label that, "on
24 cross feed," and four minutes -- hum? Is that a good number --
25 Let's say he was on cross feed for four minutes. In other

1 words, it's shortly when he reached 23,000 or just -- Take your
2 time --

3 MR. STANES: Okay. (Laughter.)

4 (Pause.)

5 MR. STACEY: So, really -- would have been on cross
6 feed at approximately 10,000 feet or slightly above. The only
7 difference is that while there's a little more -- he reflected
8 23,000 -- on four, and then he's burned a little more fuel out
9 of tanks 2 and 3, which is where the fuel --

10 MR. STANES: I mean, if he went on cross feed just as
11 soon as he could -- 23,000 pounds in tanks 1 and 4 --

12 MR. STACEY: And if you observed that as a check
13 engineer, the engineer go on cross feed at 10,000 feet with
14 23,000 pounds in 1 and 4, would that be a normal procedure?

15 MR. STANES: I would not consider it abnormal,
16 because the book says anytime between 20,000 and 23,000 pounds,
17 tanks 1 and 4, we're to go on cross feed. So -- We don't teach
18 -- We'd like them to wait a little bit longer, but if you did
19 go on 23,000, you're still standard by the book.

20 MR. STACEY: Okay. I think Norm asked, but if you
21 observed a flight engineer setting up a fuel panel in this
22 manner, as reflected in the document, flight engineer's panel,
23 as a check engineer, would you say something?

24 MR. STANES: Absolutely. This is very abnormal.

25 MR. STACEY: Do you see anything in that fuel panel

1 that would -- had he not gone for this configuration reflected
2 on the engineer's panel that is dangerous, relative to the fuel
3 balance or fuel figures?

4 MR. STANES: Are we talking the dark numbers here
5 of --

6 MR. STACEY: The heavy numbers.

7 MR. STANES: The heavy numbers, if that's what --

8 MR. STACEY: Let me ask you this: If you had those
9 heavy numbers reflected on the fuel gauges, would that be of
10 concern to you?

11 MR. STANES: No, the aircraft is -- there's no
12 problem for the aircraft, those heavy numbers. It's -- we
13 wouldn't want to see them get out of balance between 1 and 4
14 that far, but as far as structural limits of the airplane and
15 everything -- it's no problem for the airplane.

16 MR. STACEY: Okay. The heavy numbers -- a 5,000
17 pound, 51,000 pound imbalance between 1 and 4. Do you recall
18 the limit above landing weight of 1 and 4?

19 MR. STANES: Just out of my head, I think it's --
20 seems like it's -- I'd have to look in the book. I think it's
21 1,000 pounds, but -- we teach guys -- you get more than 1,000
22 pounds out --

23 MR. STACEY: I understand that, but not from 1 and 4
24 reserve, but between 1 and 4 mains, what is the lateral balance
25 limits between 1 and 4 main tanks? Do you recall?

1 MR. STANES: Offhand, I don't recall, without looking
2 in the --

3 MR. STACEY: Okay.

4 MR. STANES: -- in the book. I want to say 13,000 or
5 something like that, but I'd have to look in the book to make
6 sure.

7 MR. STACEY: Okay. So you would say well above 5,000
8 pounds.

9 MR. STANES: Yes.

10 MR. STACEY: Okay. Thank you.

11 MR. KIAPACH: When you mentioned that the arrows are
12 not in their normal position of the cross-feed valves, do you
13 think that the crew actually set this up or was this just in
14 some other way --

15 MR. STANES: I would have to think that this --
16 something like this would have happened maybe on impact. I
17 can't imagine there being a situation where the crew actually
18 set it like this. First of all, you've got a new engineer.
19 You've got a guy looking over his shoulder. You've got a sharp
20 captain. I can't imagine -- Knowing this captain, he watches
21 everything in the cockpit. I can't imagine something like this
22 being set up this way.

23 MR. KIAPACH: Okay. Thank you very much.

24 MR. BURNS: Jim, Lou Burns.

25 Assuming -- Let's assume they're in climb and they

1 have started cross feeding, and you've got -- there's 22-2 in
2 the number 1 tank and 27-3 in the number 4 tank, and the flight
3 engineer says, "I think I'd like to balance these tanks." What
4 would the procedure be to do that? How would he do that?

5 MR. STANES: If he were going to balance tanks, for
6 instance -- Of course, he would advise the captain and then
7 say, "Okay. This is what I want to do." To balance between 1
8 and 4 in this situation, you would probably see 1 and 4 or you
9 would see 1 and 4 cross-~~speed~~ valves open, which is normal
10 procedure anyway for take-off and climb. You'd see 2 and 3
11 cross-feed valves closed. The boost pumps in tank 4 would be -
12 - both would be on, and the boost pumps -- you might see one
13 boost pump -- A normal procedure would be to close one boost
14 pump on the number 1 tank. That would let two boost pumps on
15 the other side. If that's not enough to bring it within
16 balance, then you could see both boost pumps turned off in tank
17 1, and tank 4 is now supplying fuel to engine 1 and 4. That
18 would bring it within balance quickly.

19 MR. BURNS: Okay. Now, if he had already started his
20 cross feed and he sees this configuration, what would you do at
21 that point? With these figures, you've already started cross
22 feeding.

23 MR. STANES: Okay.

24 MR. BURNS: Are you going to do anything at all now
25 to balance them out?

1 MR. STANES: No, if he's already started his cross
2 feed and if he's already turned off boost pumps 1 and 4, why,
3 just continue like it is, and then once the cross-feed
4 procedure is complete, we go off cross feed, then the
5 balance --

6 MR. BURNS: Thank you.

7 MR. HALE: Charlie Hale with the IAM.

8 Have you ever come across a situation where a fuel
9 load has been given to you or someone that you're checking out
10 and it doesn't meet the criteria as far as the disbursement of
11 the fuel, but the total fuel is there, do you question that at
12 that point or do you say, "Well, I have the whole fuel. I can
13 jockey it around"?

14 MR. STANES: I'm trying to think. Maybe in 28 years,
15 once or twice I've come across a situation where the airplane
16 wasn't fueled correctly. All the fuel was there, but it was
17 not in the tanks correctly, and it was never to the point --
18 far enough out that it had to be pumped off and then pumped
19 back -- that type of thing.

20 In those two cases, I've always discussed it with the
21 captain and we determined that it would be okay --

22 MR. HALE: The other question I have is am I correct
23 in presuming that when you're checking a new engineer out that
24 he pretty much is on his own then, from what I'm gathering?
25 He's on his own. He does it, and you're just like overlooking,

1 making sure everything is done within the procedure?

2 MR. STANES: As long as he's following the standard
3 procedures, why -- Unless -- If he does something non-standard,
4 then we're going to change it immediately, but if it's --
5 within the standard procedures -- Maybe it's not real -- Say
6 the -- or something isn't there. We might discuss it later,
7 but as long as he's following standard procedures within the
8 book, then I'll let him go, and then we'll talk about it later.
9 I'm not going to jump in and start flipping switches on his
10 panel, as long as he's within the standard procedure.

11 MR. HALE: Thank you very much.

12 MR. WIEMEYER: I've got a couple of follow-ups here.
13 Did you know Mr. Crook, the --

14 MR. STANES: Oh, the -- engineer, no, I didn't know
15 him.

16 MR. WIEMEYER: You never had flown with him.

17 MR. STANES: No, never met him.

18 MR. WIEMEYER: Is the flight engineer's seat manual
19 or electric?

20 MR. STANES: Both. We have both electric switches
21 and manual levers.

22 MR. WIEMEYER: Trying to establish some sounds here.
23 If you were to get back away from the panel --

24 MR. STANES: Okay.

25 MR. WIEMEYER: -- across the aircraft, would that be

1 electric or manual or --

2 MR. STANES: You can do it either way.

3 MR. WIEMEYER: What's the common practice?

4 MR. STANES: Most people move it manually. There's
5 less noise to it, and if you run it back and forth
6 electrically, there's noise to it. First-class people can hear
7 it, so we like recommend the guys that use the manual level,
8 you know, move it yourself, but you could certainly move it
9 either way.

10 MR. WIEMEYER: And what about fore and aft? Same --

11 MR. STANES: Same way, um-hum.

12 MR. WIEMEYER: Okay. When that seat comes up against
13 a stop, is there a noise associated with it? How would you
14 characterize it if there is?

15 MR. STANES: It's designed -- If you reach the rear
16 stop, the motor just cuts out, quits --

17 MR. WIEMEYER: And what about manually?

18 MR. STANES: Manually, well, you're going to hear a
19 clunk, you know, that -- You let the lever, you move back,
20 you'll hear -- you get to the end of the -- it'll clunk.

21 MR. WIEMEYER: In general practice, you keep the seat
22 belt on all the time --

23 MR. STANES: Oh --

24 MR. WIEMEYER: What about shoulder harness?

25 MR. STANES: Shoulder harness, normal practice is we

1 keep that on take-off and landing and to initial stages of
2 climb-out, and once we start a descent, we put it on, the
3 shoulder harness, too, but for cruise flight, normal flight,
4 normally just have the seat belt on.

5 MR. WIEMEYER: Okay. At this point in the flight,
6 from what we've discussed here so far, about what -- would they
7 be through with all the check lists or would they still be in
8 one of the check lists? What would be the --

9 MR. STANES: At this point, they probably have not
10 read the after-take-off check lists, yet. Usually that comes
11 at about 17,500. The captain usually calls for the check list
12 -- 18,000, somewhere around there.

13 MR. WIEMEYER: Okay. And what is the policy and
14 practice with regards to having landing lights on during climb?
15 Is there a point where you turn them off by policy or practice?

16 MR. STANES: Usually, we -- 17,500, we usually turn
17 them off and usually that's the point that the captain calls
18 for the check lists.

19 MR. STANES: Do most people keep the landing lights
20 on until 17,500?

21 MR. STANES: Most of them.

22 MR. WIEMEYER: Are you familiar with this captain?

23 MR. STANES: Yes.

24 MR. WIEMEYER: In fact, these two captains --

25 MR. STANES: Captain Snider -- flown many flights

1 with him, and being a check engineer, he would be a captain
2 instructor, we've flown many flights together, so I knew him
3 quite well.

4 The other captain I had met a couple of times, did
5 not know.

6 MR. WIEMEYER: Was Captain Snider -- do you recall
7 what his practice was with regards to the use of landing
8 lights?

9 MR. STANES: Well, he did everything by the book, so
10 -- if the book said do a certain time, that's when he did it.

11 MR. WIEMEYER: Okay. I don't have anything else.
12 Does anybody else have anything? Terry?

13 MR. STACEY: Just one quick -- couple of quick
14 questions.

15 What -- In training and checking on a 747,
16 particularly training, from an engineer's standpoint -- well,
17 mainly from an engineer's standpoint -- what would you say is
18 the main area of emphasis?

19 MR. STANES: Probably the fuel system. We spend more
20 on that in training than any other system. Mainly because
21 that's the one that can cause most problems and get guys in
22 trouble -- That's where we have the most errors made in
23 watching new engineers and old engineers, too.

24 MR. STACEY: Did you know Dick Campbell --

25 MR. STANES: No.

1 MR. STACEY: -- engineer?

2 MR. STANES: Just from being in meetings with him.
3 I've never flown with him. I didn't know him socially or
4 anything.

5 MR. STACEY: Okay. That's all I have. Thank you,
6 Jim.

7 MR. WIEMEYER: On the scavenge pump, the light next
8 to that switch, what is that?

9 MR. STANES: That's a pressure light. Normally, if
10 there's some fuel in the center tank, you turn on the scavenge
11 pump, the light goes out, indicating that the pump is
12 operating. As the fuel is pumped out of that center tank, the
13 light will start to blink when it's getting to get down to the
14 low level, and once all the fuel is out of the tank that it can
15 possibly pick up, that light comes on steady.

16 MR. WIEMEYER: What is the normal action when that
17 light comes on?

18 MR. STANES: When the light comes on, normally, we
19 shut it off. That's --

20 MR. WIEMEYER: Okay. As a check engineer, how long
21 would you let your student leave that light on before you said
22 something to him?

23 MR. STANES: Once it comes on, maybe I might wait 30
24 seconds or so, a minute. He should be able to see it, spot it
25 by then. If he hasn't spotted it by then, I mention it to him.

1 "Hey, the lights on. It should come off."

2 MR. WIEMEYER: Based on your training experience, is
3 there any real danger if the light is on. They don't shut --

4 MR. STANES: On the 747, nothing I can recall with
5 any problem with it. Seem like I remember hearing 767s
6 possibly problems, but I never encountered a problem with a 747
7 that I know of, but, again, I don't know why you would leave
8 the pump on anyway.

9 MR. WIEMEYER: Well, you've drained my question bank.
10 I don't have anything else. Does anybody else? This is your
11 chance. We've got an expert here. We ought to take advantage
12 of him, so if there's anything else anybody wants to bring up,
13 now is the time.

14 Okay. We certainly do appreciate --

15 (Whereupon, the interview was concluded.)

16

17

18

19

20

21

22

23

24

25

BEGORE X-SEED

QU ZTW
M W 000000

TWA FUEL LOAD SERVICE RECORD M-180C

17 JUL / 1805

STA JFK PLANE 17119 FLT 900 AGENT JC FUEL TYPE A

TOTAL FUEL 181100 LBS WITH TAXI TYPE LOAD STANDARD/STD

TANK	BEFORE FUELING	PLANNED POUNDS	AFTER FUELING	INOOPERATIVE FUEL GAUGE NR INCHES/LBS TRUCK-METER	GAL
IR		3350	3,400	3,400	500
1	5,400	24596	7,400	21,000	3671
2	5,300	62605	6,790	58,000	9344
CTR	300	0	300	0	0
3	6,900	62605	6,770	58,000	9344
4	6,300	24596	7,460	21,000	3671
4R		3350	3,300	3,300	500

TOT 24,200 181100 181,800

READINGS BY VERIFIED BY

AFTER FUELING 181,800 (LBS)

(SUBTRACT) (-) 24,200 (LBS)

BEFORE FUELING 157,600 (LBS)

(EQUAL) CALCULATED ADD 15,760 (LBS) (/) DIVIDED BY 6.70 FUEL DENSITY *

EQUAL CALCULATED ADD 23,522 (GAL) * * * * *

TRUCK METER READINGS COMPARE

LEFT RIGHT

AND.....EQUAL TOTAL 23,871 (GAL) (COMPARE TO CALCULATED ADD)

ADD TOLERANCE PLUS/MINUS 650 (GAL) CALCULATED BY

COMPARE CALCULATED ADD GALLONS TO TRUCK METER ADD GALLONS. IF DIFFERENCE IS GREATER THAN ADD TOLERANCE CONTACT OPERATIONS PRIOR TO DEPARTURE.

ENGINE OIL (QUARTS) FUEL SERVICED BY (EMPLOYEE ID)

1 2 3 4 OIL SERVICED BY LEFT RIGHT

DATE/TIME 17 July

PLACE COMPLETED COPY BETWEEN COCKPIT THROTTLES AND RETURN ORIGINAL TO TWA OPERATIONS FOR FILING.

FLIGHT CREW SIGNATURE NOT REQUIRED ON FUELERS COPY.

NOTE- FUEL WITH 4500 TAXI...BUST PREVIOUS FUEL PER DISPATCH

KA4 00091 07/172206

EXHIBIT 2

11/20/96 JM

PRINTED ON REGENESIS

PENGAD-Boynone, N. J.
 EXHIBIT
 3
 11/22/70 dm

588.0
 587.0
 169.0
 170.0

BEFORE X-FEED

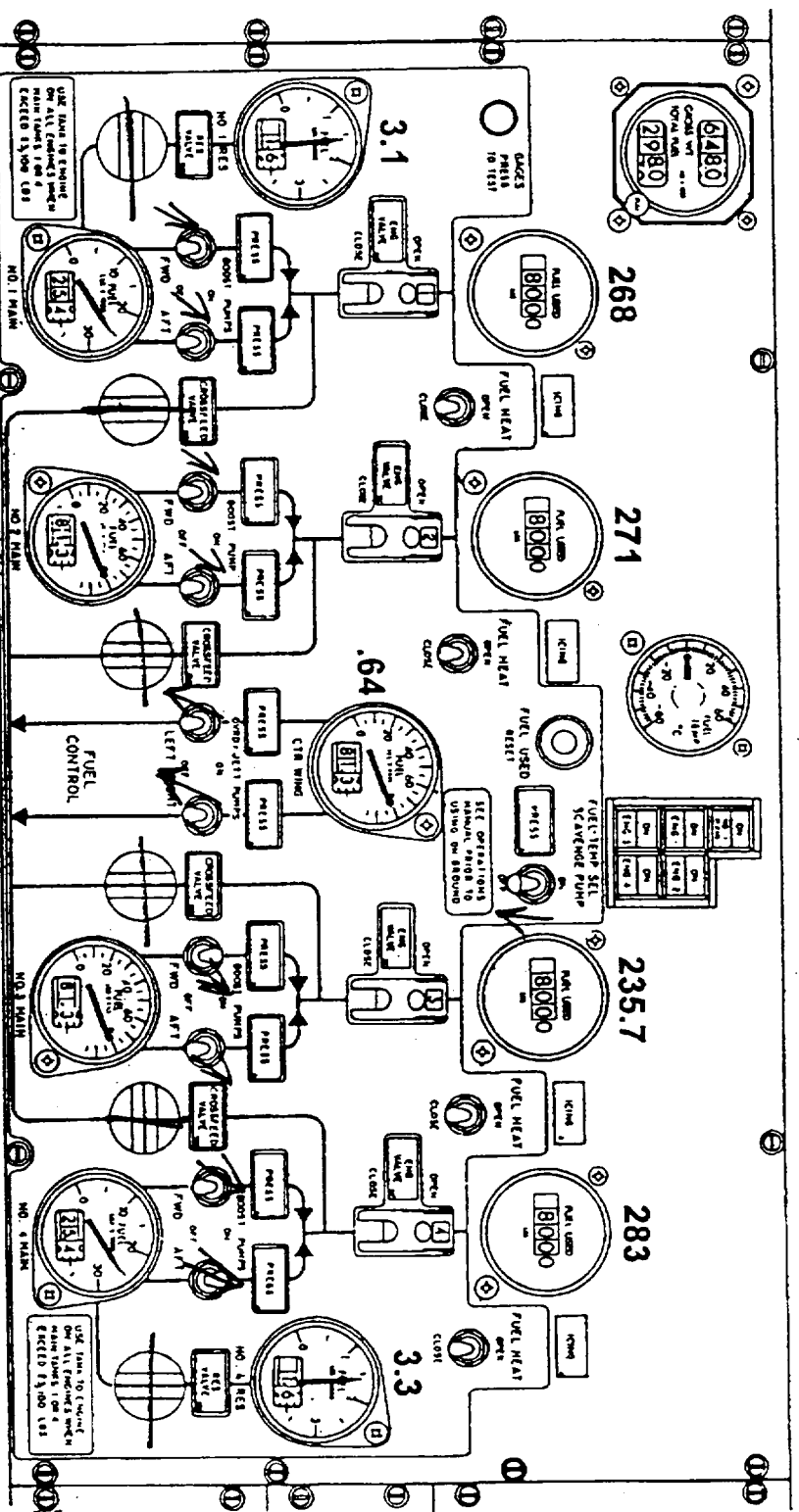

FLIGHT ENGINEERS PANEL

Proprietary
 THE BOEING COMPANY

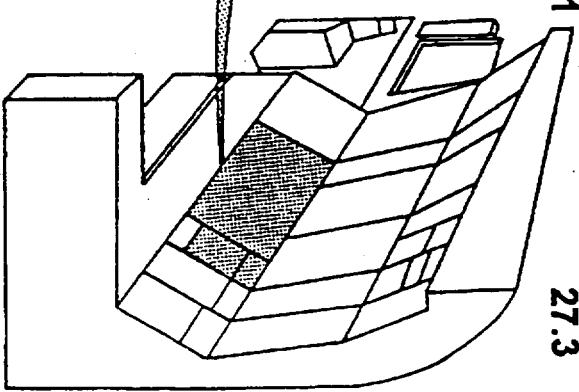

07/20/96

12:53

ON X-FEED : 04 mi

NO. 079 001

QU ZTW
M H 000000

TWA FUEL LOAD SERVICE RECORD M-180C

17 JUL 1985

STA JFK PLANE 17119 FLT 800 AGENT JC FUEL TYPE *A*

TOTAL FUEL 181100 LBS WITH TAXI TYPE LOAD STANDARD/STD

TANK	BEFORE FUELING	PLANNED POUNDS	AFTER FUELING	INOPERATIVE FUEL GAUGE NR INCHES/LBS TRUCK-METER	GAL
1R	3350	3400	3400	500
1	5400	24596	24600	23,000	3671
2	5300	62605	62900	60,000	9344
CTR	300	0	300	0	0
3	6900	62605	62700	60,000	9344
4	6300	24596	24600	23,000	3671
4R	3350	3300	3300	500
TOT	24200	191100	181800		

* AFTER FUELING * 181800 (LBS)
 * (SUBTRACT) (-) 24200 (LBS)
 * * * BEFORE FUELING

(EQUAL) CALCULATED ADD 15760 (LBS) (/) DIVIDED BY 6.70 FUEL DENSITY *

EQUAL CALCULATED ADD 23522 (GAL) * * * * *

TRUCK METER READINGS COMPARE
 LEFT RIGHT * * *
AND.....EQUAL TOTAL 23871 (GAL) (COMPARE TO CALCULATED ADD)

ADD TOLERANCE PLUS/MINUS 650 (GAL) CALCULATED BY

COMPARE CALCULATED ADD GALLONS TO TRUCK METER ADD GALLONS. IF DIFFERENCE IS GREATER THAN ADD TOLERANCE CONTACT OPERATIONS PRIOR TO DEPARTURE.

ENGINE OIL (QUARTS)

1 2 3 4 OIL SERVICED BY

FUEL SERVICED BY (EMPLOYEE ID)
 LEFT RIGHT

DATE/TIME *7 July*

PLACE COMPLETED COPY BETWEEN COCKPIT THROTTLES AND RETURN ORIGINAL TO TWA OPERATIONS FOR FILING.

FLIGHT CREW
 SIGNATURE NOT REQUIRED ON FUELERS COPY.

NOTE- FUEL WITH 4500 TAXI...BUST PREVIOUS FUEL PER DISPATCH

KA4 00091 07/172206



ASSUMER RECTURE IS PAPER

PRINTED ON REGENESIS

110 AIRCRAFT