

NATIONAL TRANSPORTATION SAFETY BOARD

Office of Research and Engineering
Materials Laboratory Division
Washington, D.C. 20594



June 11, 2008

MATERIALS LABORATORY FACTUAL REPORT

Report No. 08-048

A. ACCIDENT

Place : Salt Lake City, Utah
Date : January 23, 2008
Vehicle : Boeing MD-82
Operator : American Airlines, Flight 1400
NTSB No. : ENG08SA009
Investigator : Harald Reichel, AS-40

B. COMPONENTS EXAMINED

Air filter P/N 11-10656

C. DETAILS OF THE EXAMINATION

The as-received air filter assembly is displayed in figure 1. The components included the filter housing and separated filter element assembly. The housing was marked "HRT Part No. 11-10656 S/N 1187". The end cap of the filter element was marked "Lot No. 0067" and part number "21-10930".

As received, the filter element was transversely separated just above the lower braze line as shown in figure 2 and 3 (a) and (b). Both sides of the separation displayed severe mechanical damage and rubbing that obliterated the majority of the fracture features, see figure 3 (c) and (d) and figure 4. However, one pleat on the fitting side of the fracture was relatively undamaged as indicated in figure 4. In this pleat, the longitudinal wires of both the fine outer screen and coarse inner screen were fractured and relatively undamaged.

Scanning electron microscope (SEM) viewing found that both the fine and coarse wires were fractured at the intersection with the cross wires as shown in figures 5 and 6. High magnification viewing revealed features consistent with fatigue propagation completely through both the fine and coarse wires. Fracture traces indicated that the fatigue initiated at the contact points with the cross wires and propagated completely through the wire cross sections, as indicated in figure 6.

The housing was longitudinally sectioned (see figure 7 (a)). Examination of the interior surface after sectioning showed a circular burnished band where the original machined finish had been polished smooth as shown in figure 7 (b). The band was located at the approximate installed location of the filter element end cap. The outer diameter of the end cap displayed matching burnishing as shown in figure 7 (c).

Joe Epperson
Senior Metallurgist

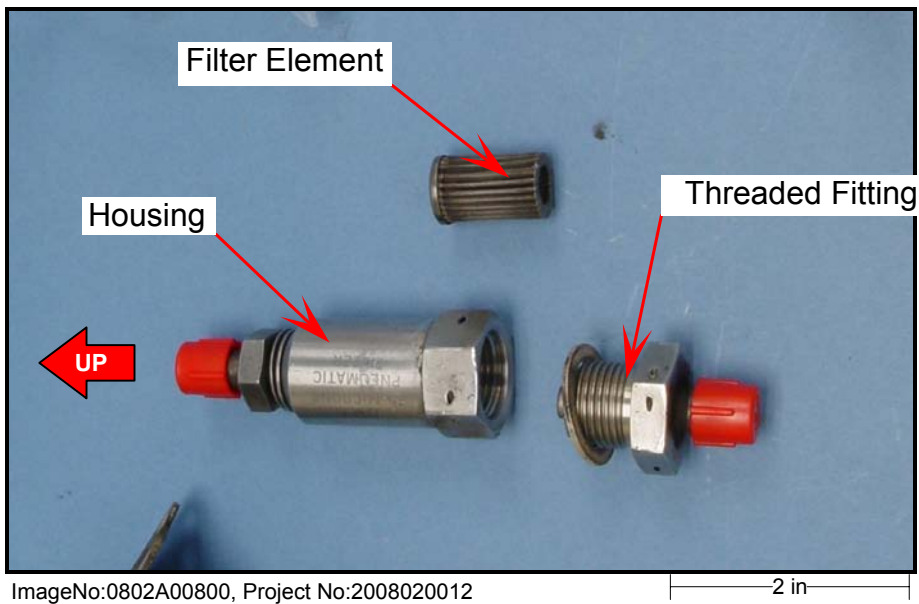

Figure 1--The as-received components with separated filter element.

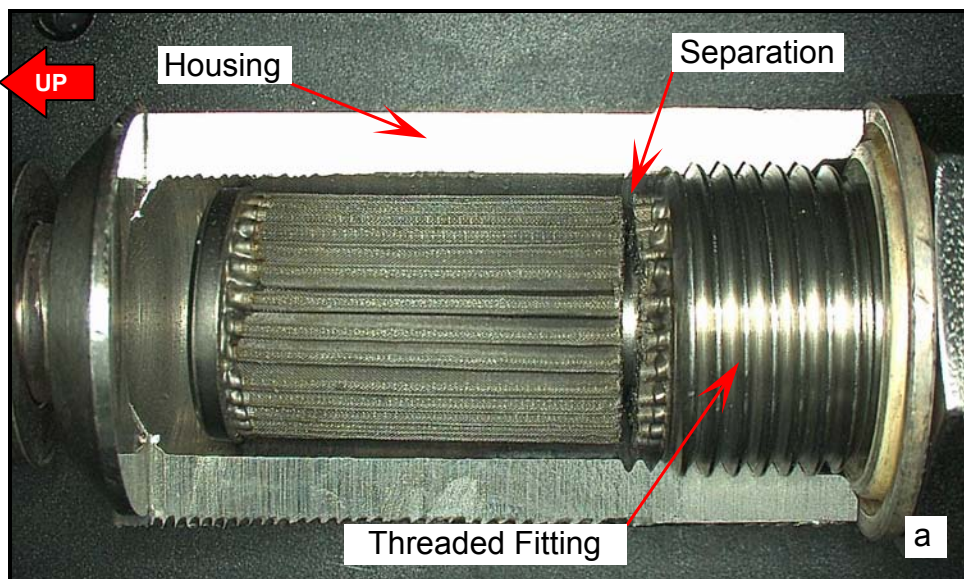
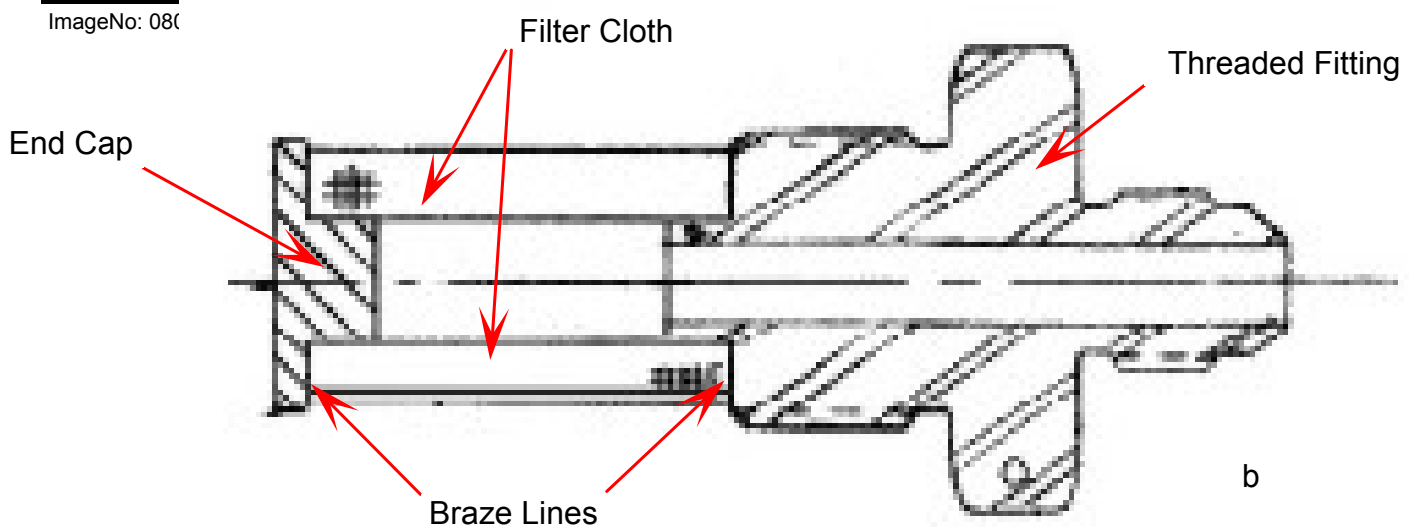

Figure 2--The filter element and fitting placed in the sectioned housing (a). An illustration of the filter assembly construction (b).



ImageNo: 080

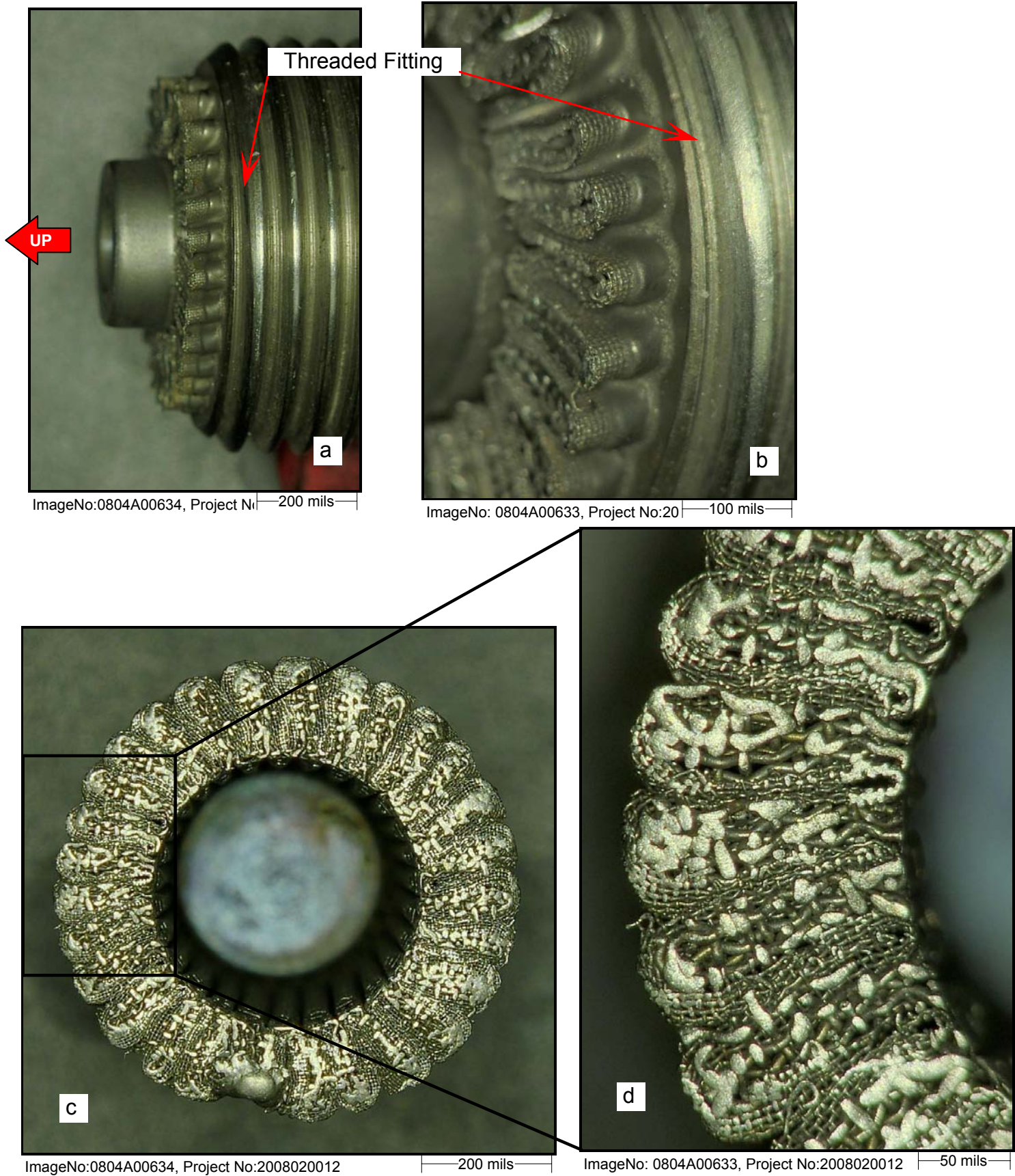

Figure 3--The element separation adjacent to the lower braze line (a) and (b). The damaged element side separation showing extensive damage (c) and (d).

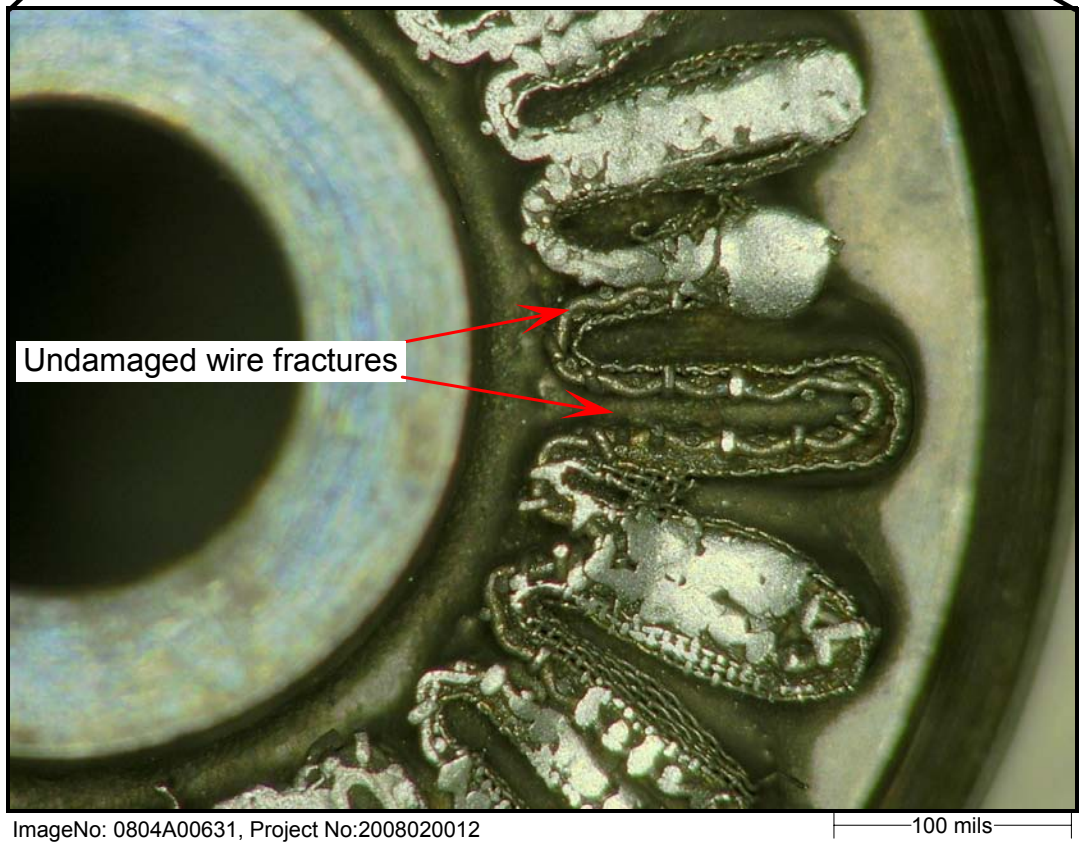
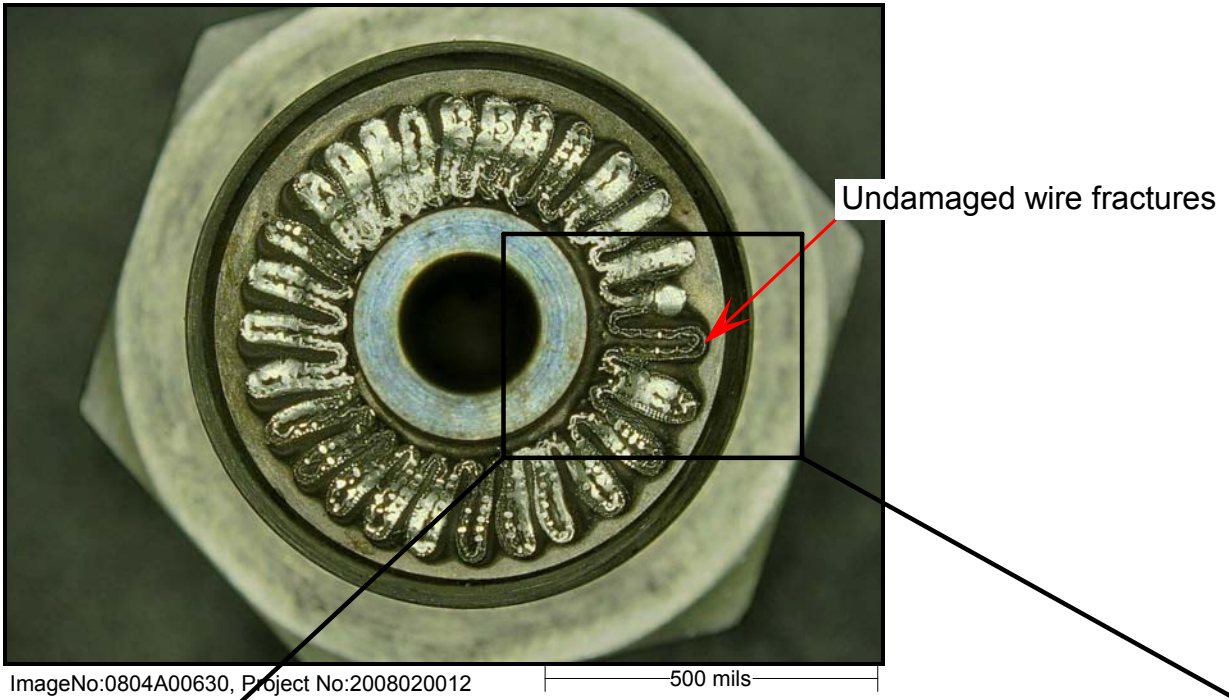

Figure 4--The fitting side separation showing the pleat with undamaged wire fractures.

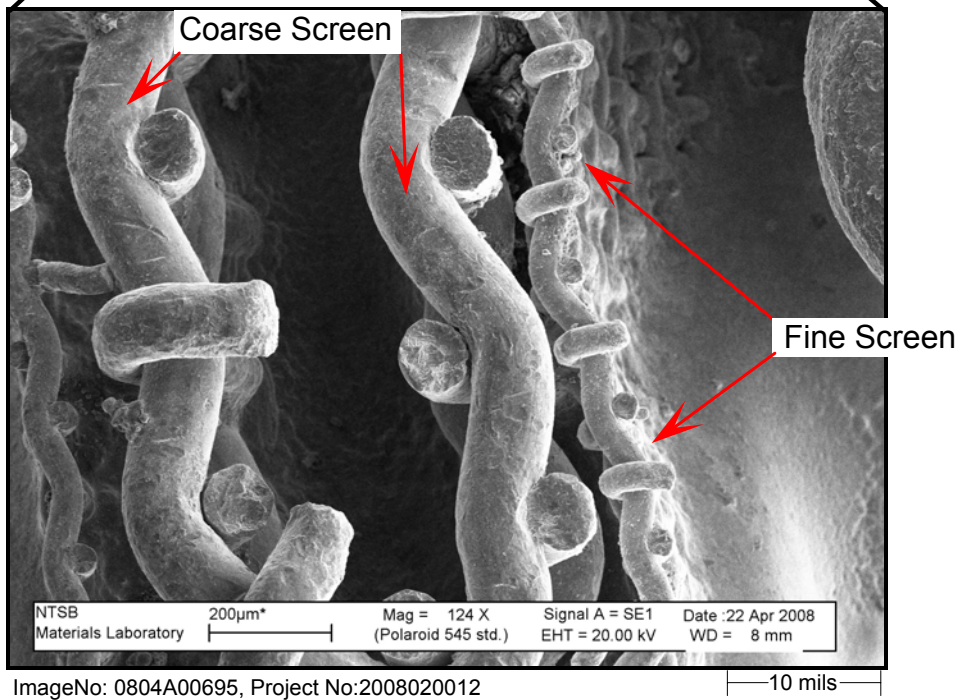
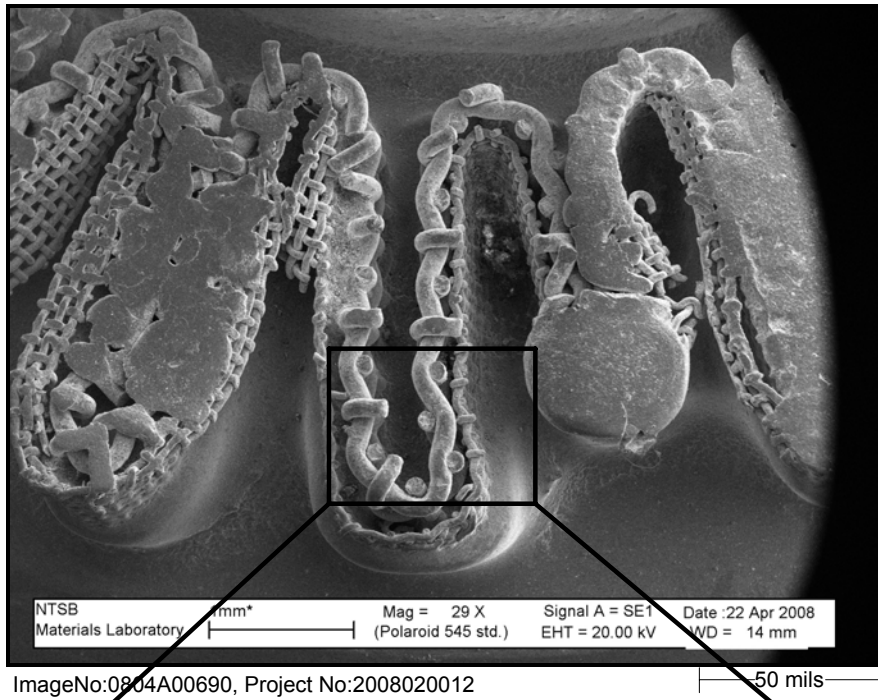

Figure 5--SEM views of the undamaged wire fractures.

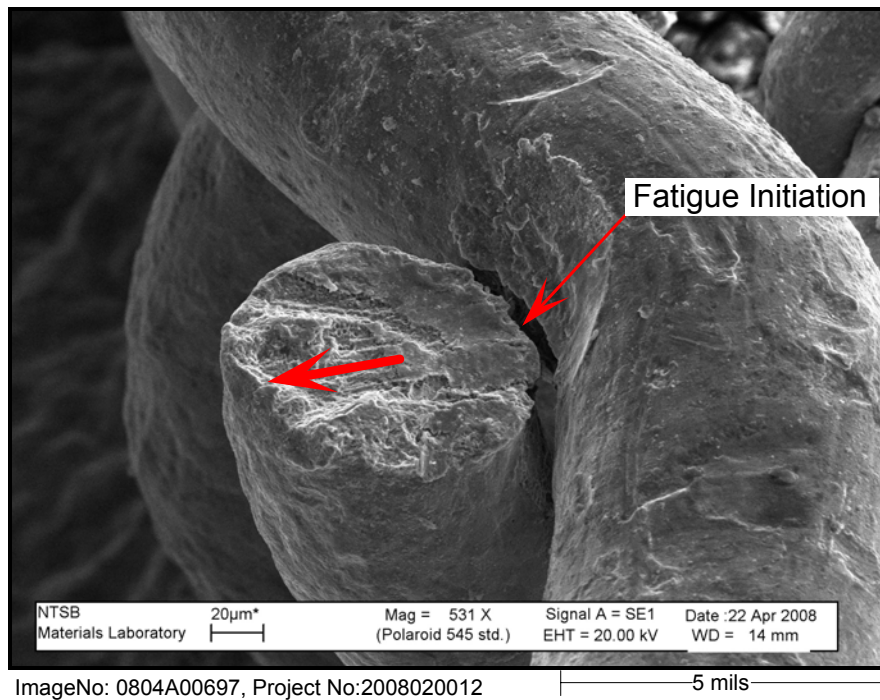
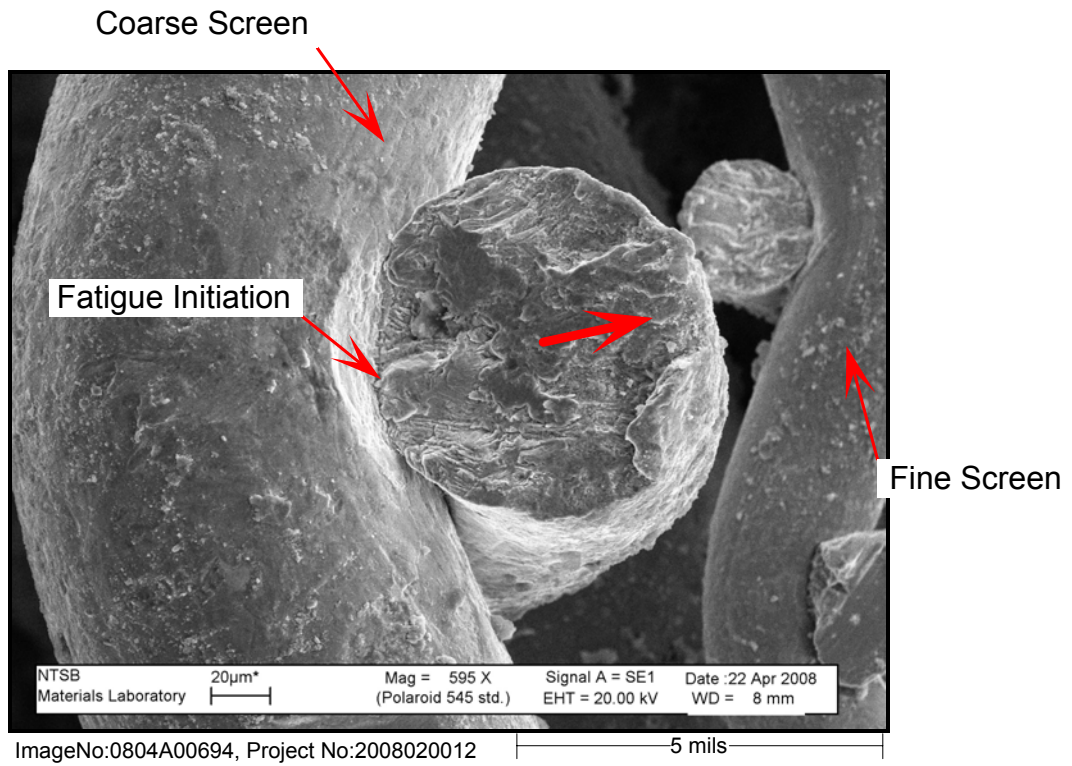
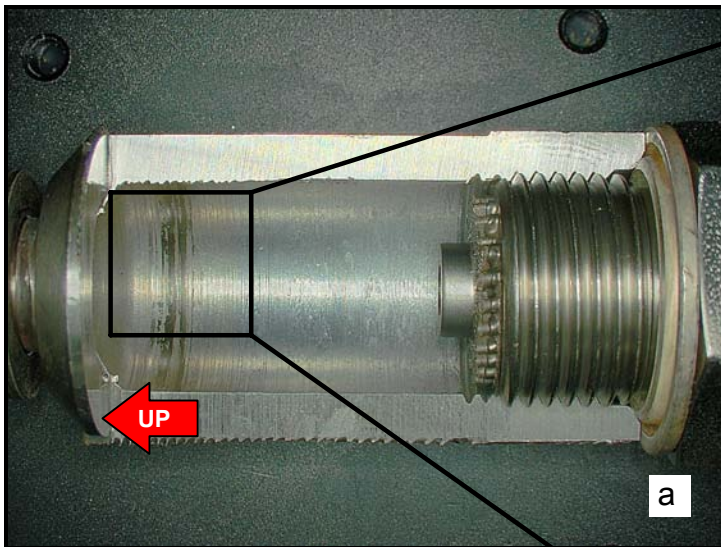
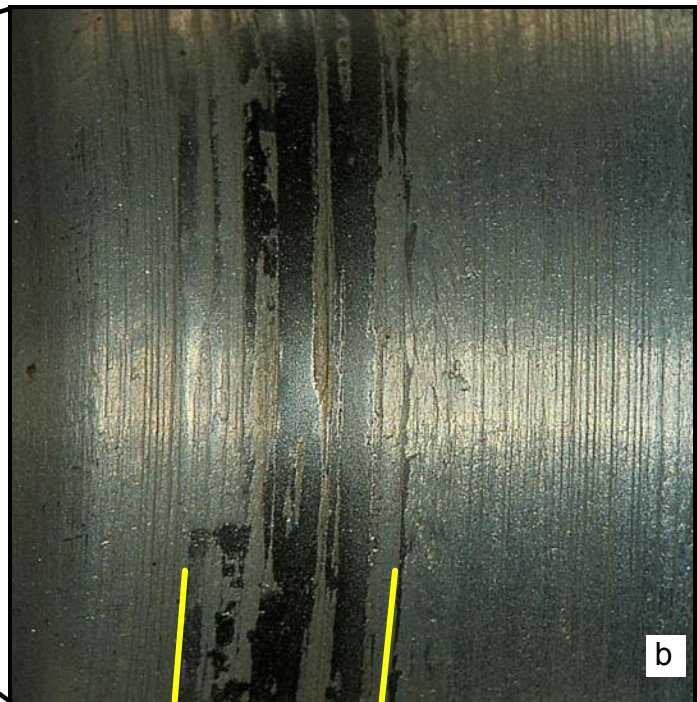

Figure 6--Typical fractures on coarse wires. Initiation at intersections with cross wires. Propagation indicated by bold arrows.



ImageNo:0804A00736, Project No:2008020012



ImageNo: 0804A00733, Project No:2008020012

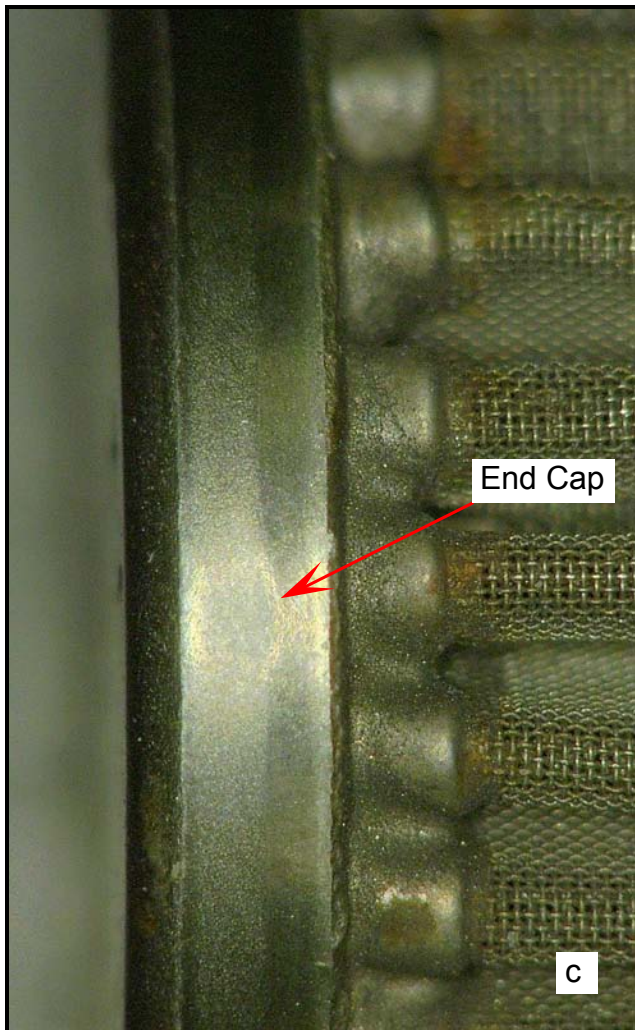

ImageNo:0804A00736, Project No:2008020012

Figure 7--The interior of the housing (a) showing a burnished band between the yellow lines in (b). The burnished and polished outerr diameter of the filter in cap in (c).