

**DENNEY**

**AEROCRAFT**

**COMPANY**

September 12, 1991

**SERVICE BULLETIN #9**

**SUBJECT:** Flaperon hanger rib  
**TO:** KITFOX MODEL I, II, III owners  
**FROM:** Denney Aircraft Company

There have been two cases of Kitfox flaperon hanger rib failure documented in the United Kingdom. In both cases the failure appeared to be from side load overstress. Both aircraft had been in recent prior ground accidents. One was in an automobile accident while being transported on a trailer. The other mishap involved a nose-over upon landing. In both cases it is very likely that there were excessive side loads placed on the flaperon hangers which could have contributed to the subsequent failures. In the latter case the failure occurred on the ground during a period of engine operation at very low RPM's including engine operation on one cylinder, which caused the entire aircraft to shake violently. There was no personal injury to any persons in either case.

As a result of these occurrences the PFA/CAA in England have grounded the entire Kitfox fleet, subject to a modification of the flaperon hanger ribs that will meet or exceed United States FAR Part 23 requirements for control surface mass-balance supporting structure.

We have designed and tested reinforcements for the flaperon hanger ribs that can be readily fitted to Kitfox wings under construction or retro fitted to wings already completed. These modified ribs will withstand up to 150 lbs side load each when in reality the load will most likely be spread over the 5 hanger ribs. FAR 23 requires a side load capability of 12G's and 24 G's normal to the plane of the control surface. The flaperon with the Denney Aircraft mass balance weighs 7 pounds so you can see that it will withstand a side load of over 21 G's with the modification. We also tested standard un-modified ribs and they withstood 90 lbs of side load (12G's). In essence they met the Part 23 requirement for side loads without the reinforcement.

To meet the requirements of FAR 23 for in-plane loads of 24 G's the reinforcement must be installed on the two outboard ribs. (This assumes you have positioned your Denney Aircraft Co supplied mass-balance in the prescribed position near the outboard end of the flaperon). You should also install the reinforcement on each inboard rib to compensate for slack in the bearing or failure of the fuselage/turtledeck support bearing. If you desire to reinforce all ten flaperon hanger ribs that is ok but not necessary UNLESS you have installed the rod type mass-balance inserted in the leading edge of the flaperon as some have done in the U.K. If you have used the rod-type mass balance method then you should reinforce all 10 flaperon hanger ribs.



The reinforcements consist of left and right .025" 2024-T3 aluminum angles riveted to each side of each flaperon hanger rib end. Each angle is 8 inches long and tapers from a depth of 1.2 inches to .8 inches with a flange of .4 inch. This flange fits flush against the bottom of the rib capstrip. The reinforcement angles are fastened to the tail of each hanger rib with 6 each 1/8 inch x 5/16 inch long blind "POP" rivets. Each aluminum angle is also riveted to the rib capstrip with 3 each 3/32 inch x 3/16 inch rivets. The builder will have to round the ends of each reinforcement angle to match the rib. He can at his option apply FSA-2 structural adhesive or the equivalent to the mating surfaces for increased joint strength. If this is done the reinforcement angle should be cleaned with acetone or MEK and rough sanded with 100 grit sandpaper.

To retrofit the reinforcement strips to a wing that is already covered, you will have to slit the fabric from the trailing edge about 8 inches forward along the centerline of the bottom of the hanger rib. Slit the fabric along the trailing edge about 6 inches on each side of the rib. Then you can pull the flap of fabric back away from the rib so you can drill rivet holes and install the reinforcement angles.

To repair the fabric you will have to remove the paint and dope down to bare fabric with Stits reducer, MEK, or other suitable solvent. Then use fabric tape to cover the slits and use Stits Poly-Tac, Poly-Brush, and Poly-Spray to attach and coat the tapes. Heat-shrink the patches and repaired areas to restore tautness to those areas. Repaint.

This modification is recommended but not required except in the U.K. It is available to you from Denney Aircraft Co. at a cost \$30.00 which **includes** shipping costs. You could also fabricate it yourself. *KIT PIN 69076.000*

NOTE: Do not idle or run the engine in the low RPM range of 0-2000 RPM except passing through this range in starting and shutdown.

**Attached Drawing D28002 Wing Rib Reinforcement**

*If you need assistance in any way, please call customer service, before returning any items to Denney Aircraft Co. Please obtain a Return Goods Authorization (RMA) number from customer service.*

D28002

DENNEY AEROCRAFT COMPANY  
100 NORTH KINGS ROAD  
NAKPA IDAHO 83687

WING RIB REINFORCEMENT  
ALL DIMENSIONS ARE IN INCHES  
± .02 EXCEPT WHERE NOTED  
DRAWN BY DANIEL MACPHERSON  
DATE: 8-20-91  
LAST REVISION: 8-27-91

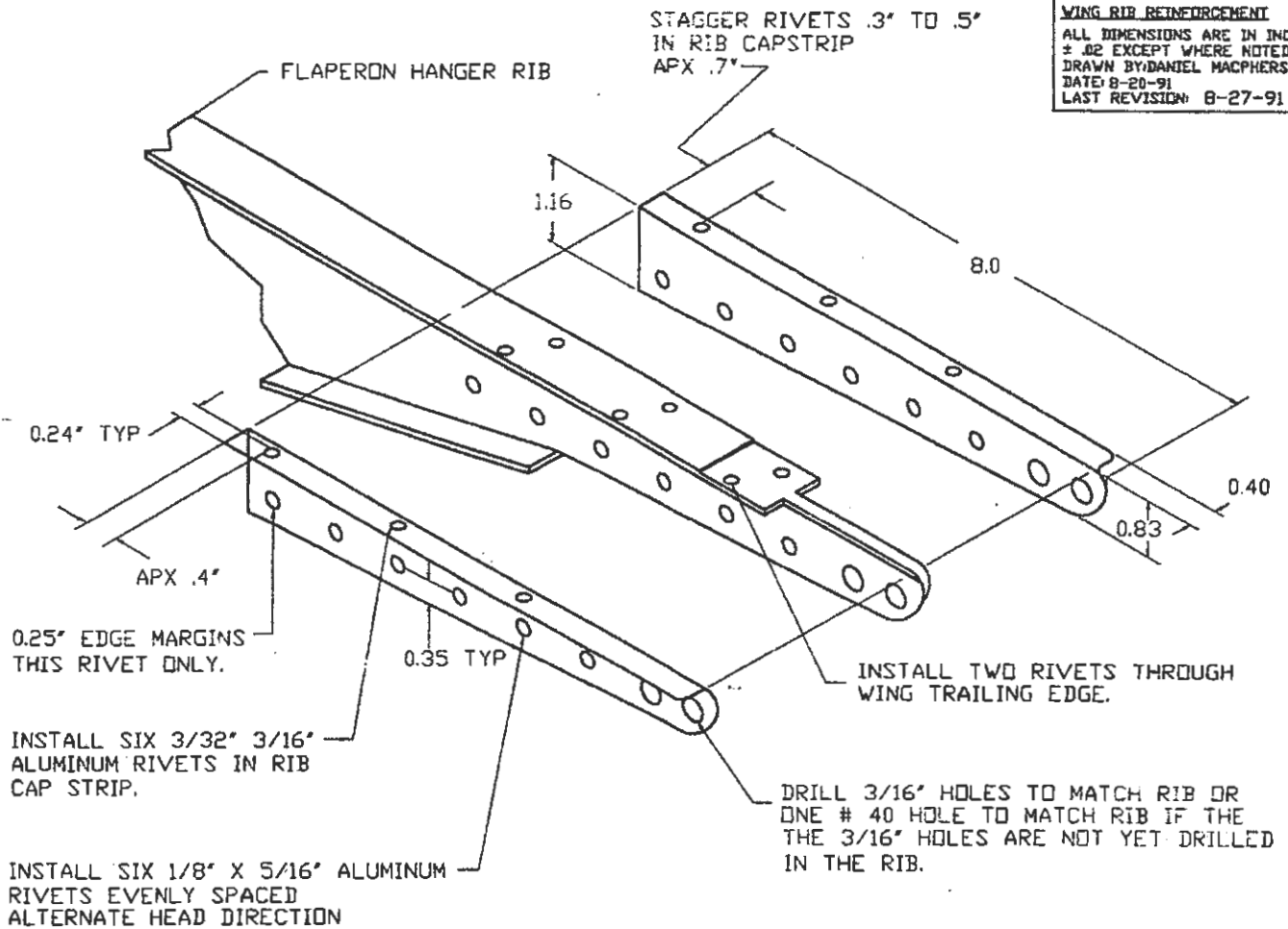

REINFORCEMENT MATERIAL: 0.025" 2024-T3 ALUMINUM  
PART DIMENSIONS ARE TO OUTSIDE SURFACE

