

652 Oliver Street
Williamsport, PA 17701 U.S.A.

Tel. 570-323-6181
Fax. 570-327-7101
www.lycoming.textron.com

SERVICE INSTRUCTION

DATE: December 9, 2005 Service Instruction No. 1438A
(Supersedes Service Instruction No. 1438)

SUBJECT: Propeller Governor Pad Plate P/N LW-12347

MODELS AFFECTED: All four and six cylinder, dual magneto engines with rear mounted propeller governor drives.

TIME OF COMPLIANCE: Anytime the propeller governor is installed.

The use of a P/N LW-12347 propeller governor pad plate and two P/N 72053 gaskets on dual magneto engines with rear mounted propeller governor drives is necessary with some propeller governors to eliminate the possibility of oil leakage between the propeller governor and the accessory housing.

As a product improvement, to insure against oil leakage, the propeller governor pad plate and gaskets are being incorporated and will not effect operation with any propeller governor drive installed on the engines. See illustration.

CAUTION

WHEN INSTALLING THE PROPELLER GOVERNOR, THE P/N 72053 GASKET BETWEEN THE PROPELLER GOVERNOR PLATE AND THE COVER IS REPLACED BY A GASKET SPECIFIED BY THE AIRFRAME OR PROPELLER GOVERNOR MANUFACTURER. (REFER TO AIRFRAME IPC.) LYCOMING DOES NOT SUPPLY THIS GASKET; HOWEVER, IT MAY BE PURCHASED THROUGH THE AIRFRAME OR PROPELLER GOVERNOR MANUFACTURER.

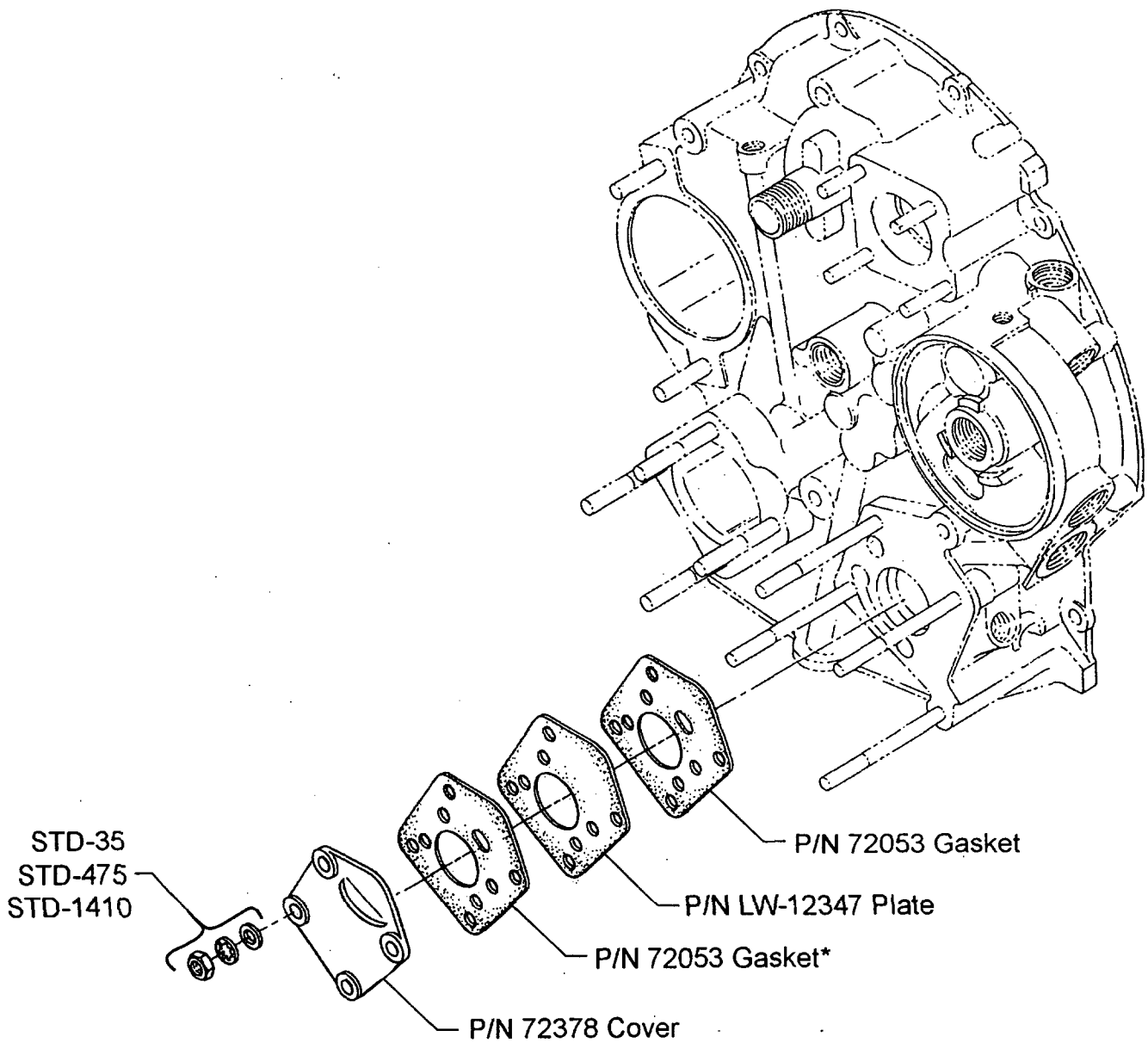

* Replaced by gasket specified by airframe or propeller governor manufacturer when propeller governor installed.

Propeller Governor Pad Plate and Gaskets