

**MP 608 – Marshall, Michigan Incident  
NTSB/PHMSA Information Request No. 43**

- 43**     **Reference:**     August 30, 2010 Email Request from Matthew Nicholson
- Preamble:**
- Request:**        **Please load the Pipeline Survey results from the field survey  
                                 onto the FTP site.**
- Response:**     Attached: Pipe Install Detail REV 3.pdf

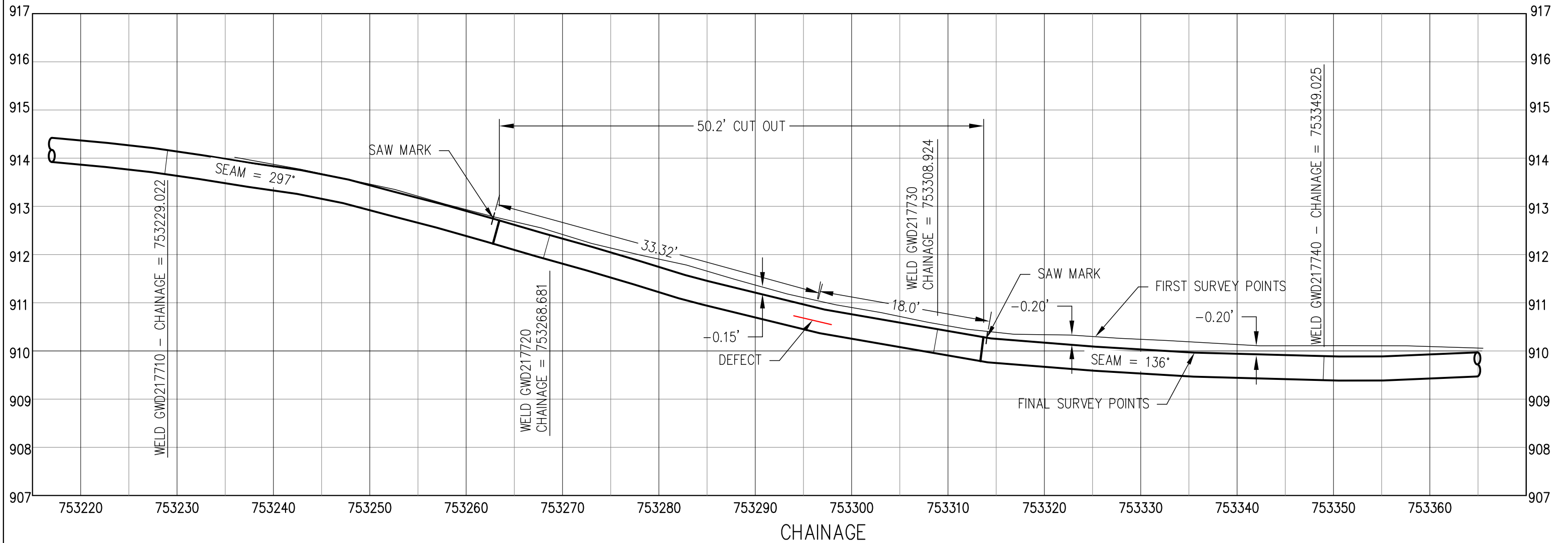
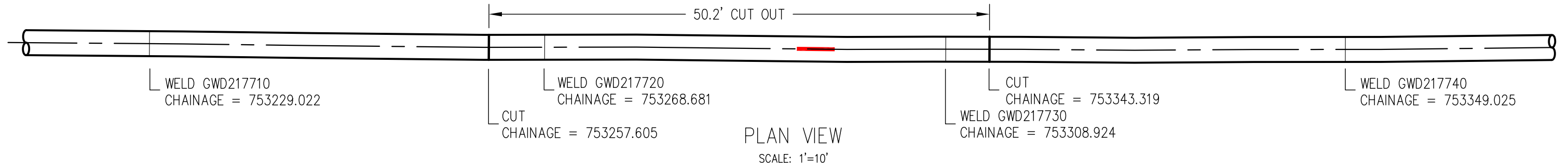

NOTES:  
VERTICAL ACCURACY OF GPS ±0.07 FEET

NO.	REVISION DESCRIPTION	DATE	BY	APP'D
1.	ISSUED	8/06/10	ND	BP
2.	REVISED TO ADD FINAL SURVEY DATA	8/06/10	ND	BP
3.	ADD SEAM DATA	8/06/10	ND	BP



6B REPAIR  
PIPE EXCAVATION ELEVATIONS