

Appendix Q
Hazardous Materials Group Factual

Seat-belt Pretensioner Information



Secretariat

Distr.
GENERAL

ST/SG/AC.10/2000/11
21 September 2000

ORIGINAL : ENGLISH

**COMMITTEE OF EXPERTS ON THE TRANSPORT
OF DANGEROUS GOODS**

*(Twenty-first session,
4-13 December 2000,
agenda item 2 (b))*

**WORK OF THE SUB-COMMITTEE OF EXPERTS
ON THE TRANSPORT OF DANGEROUS GOODS**

Draft amendments to the Recommendations on the Transport of Dangerous Goods

Proper shipping name of the entries of UN Nos. 0503 and 3268

Transmitted by the expert from Japan

Introduction

1. At the eighteenth session of the Sub-Committee of Experts "GAS GENERATORS FOR SEAT BELTS" was approved provisionally (square brackets) as one of proper shipping name for UN Nos. 0503 and 3268. Some experts pointed out the inadequacy of the term "GAS GENERATORS" for such articles. The expert from Japan offered to provide a description of such articles and to prepare a proposal for the proper shipping name for the Committee's session (ST/SG/AC.10/C.3/36, para. 59).
2. The description of the typical article manufactured in Japan is as follows:
 - 2.1 Seat-belt pretensioners are devices intended to tighten the seat belt in order to restrain a car occupant as early as possible during the very first fractions of a second in a crash. The actuator (also called "micro gas generator" by the Japanese industry) for seat-belt pretensioner is a small pyrotechnic device, which actuates the pretensioner, and actually tightens the seat belt. A diagram of an actuator is reproduced in the Annex to this document.

000002

GE.00-

2.2 Dimensions and pyrotechnical components of actuators

(1) Dimensions

Length and Diameter: App.30mm and app. 17mm

Gross mass: App.10g or less

(2) Pyrotechnical components

Squib charge: ZPP(Zirconium perchlorate) or BKNO₃(Boron potassium nitrate)

Net mass: App. 0.1g

Pyrotechnic propellant: Almost all Nitrocellulose

Net mass: App.1g

2.3 Mechanism of actuation

- (1) A crash sensor sends an electric current signal to the bridge wire (heater) in the event of frontal collision.
- (2) The heater ignites the squib charge and consequently the pyrotechnic propellant inside the canister.
- (3) The propulsion force can tighten the seat belt up to around 10 to 15 cm.

2.4 Test results

The following tests have been carried out for actuators for seat-belt pretensioners in the transport package in accordance with the United Nations Manual of Tests and Criteria and their results were negative.

- (1) Thermal stability test
- (2) Twelve metres drop test
- (3) Single package test
- (4) External fire test

Proposal

3. Amend the name of [GAS GENERATORS FOR SEAT-BELTS] in the column 2 of Dangerous Goods List and Special Provision 280 (ST/SG/AC.10/C.3/36/Add.1, page 7 and 9) to read : "ACTUATORS FOR SEAT-BELT PRETENSIONERS"

* * * * *

000003

Annex

Diagrams of the actuators for seat-belt pretensioners

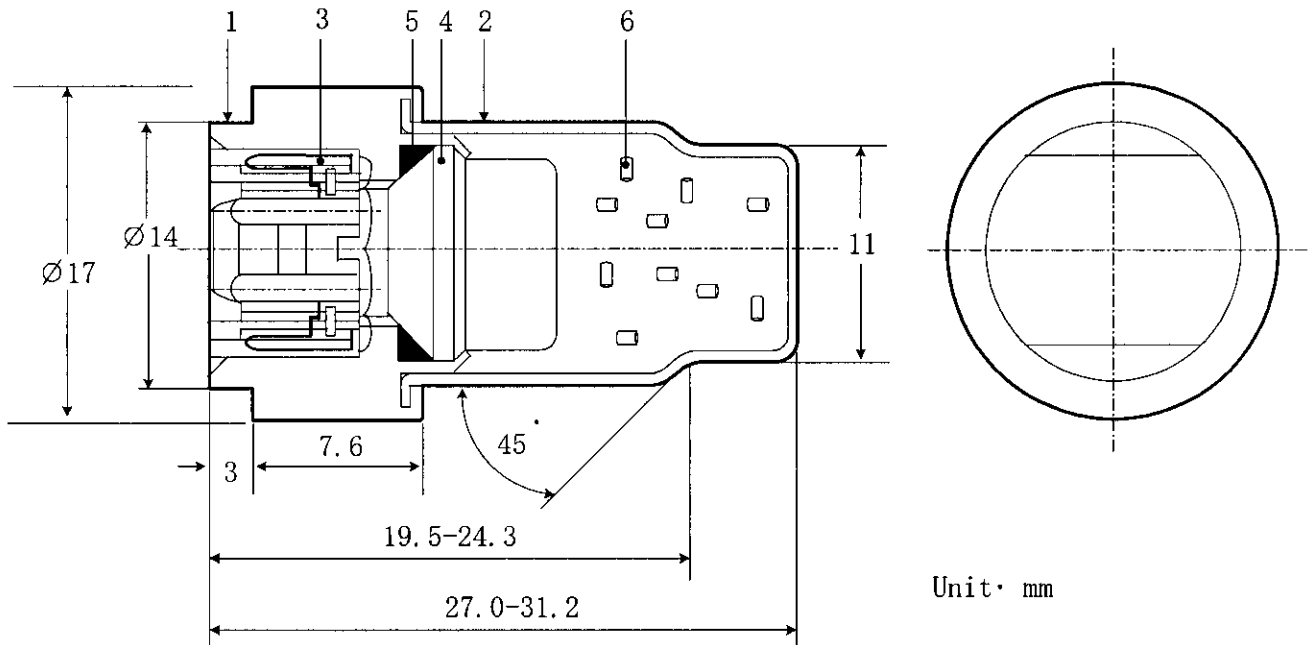

Unit: mm

- 1X Holder
- 2X Cup
- 3X Shorting crimp
- 4X Squib
- 5X O-ring
- 6X Pyrotechnic Composition

000004