

DOCKET NO. **SA- 516**

EXHIBIT NO. **23D**

**NATIONAL TRANSPORTATION SAFETY BOARD
WASHINGTON, D.C**

COMPONENT DRAWINGS

(4 Pages)

PNEUMATIC SYSTEM SCHEMATIC DIAGRAM

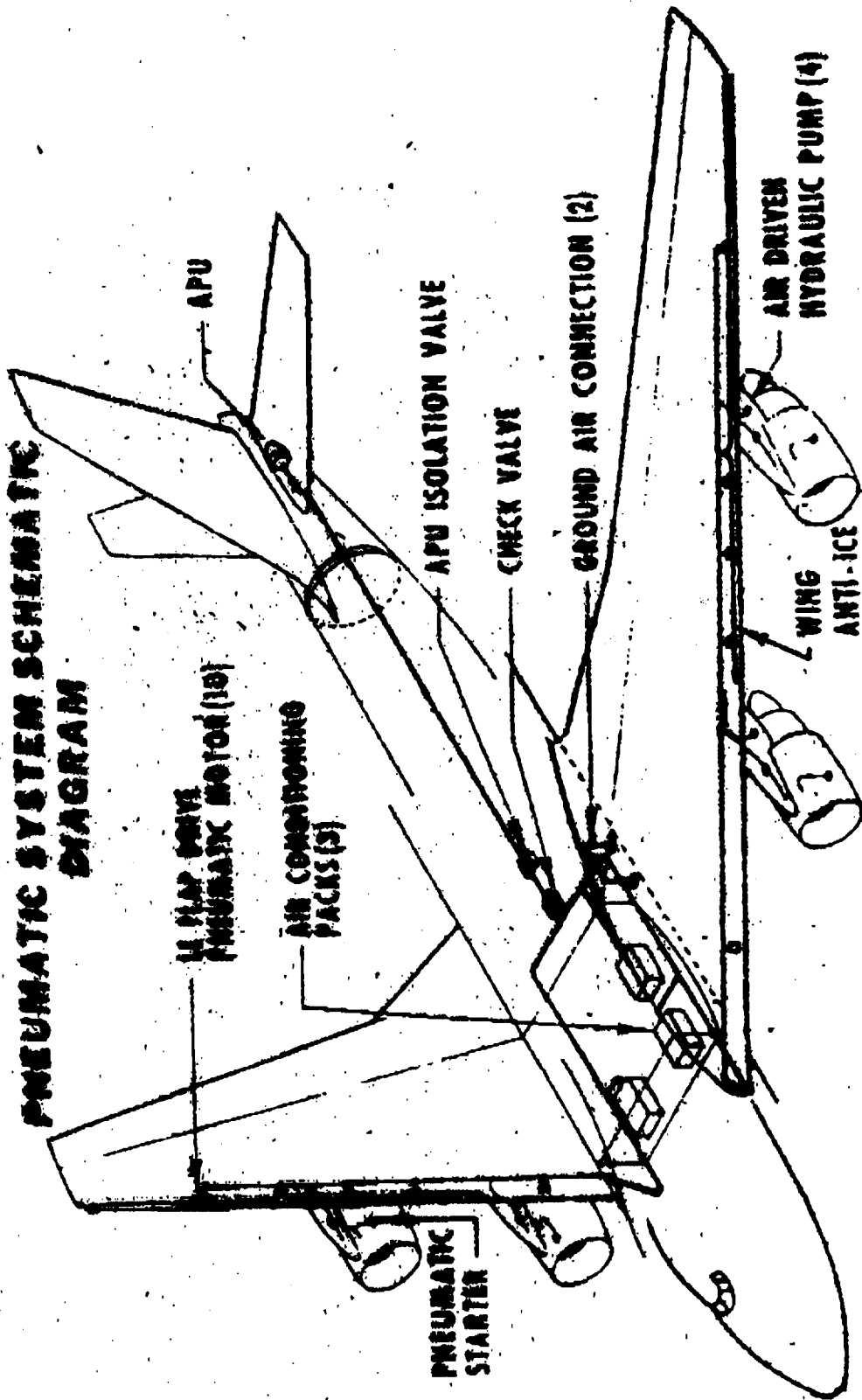

747

747-100 Center Wing Tank Schematic

Side View

Forward is to the Left

Color Key

■	0
■	0
■	0
■	0
■	0

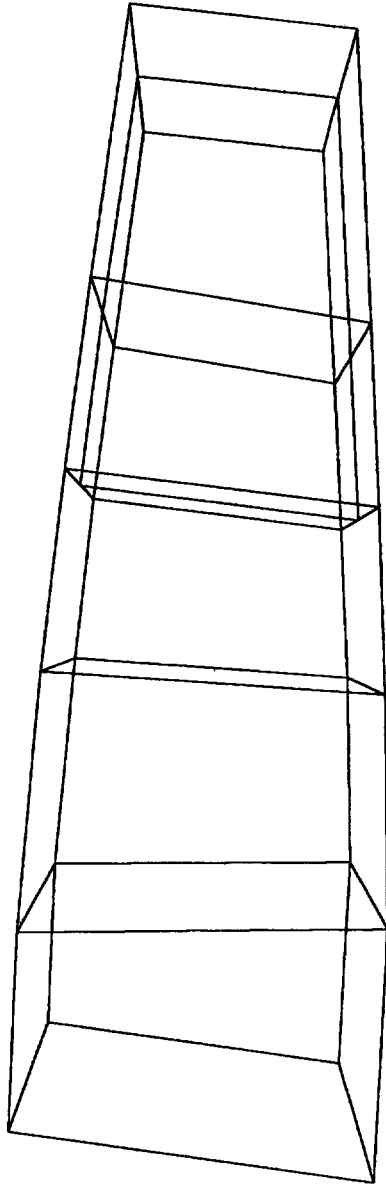

747-100 Center Wing Tank Schematic

Side View

Forward is to the Left

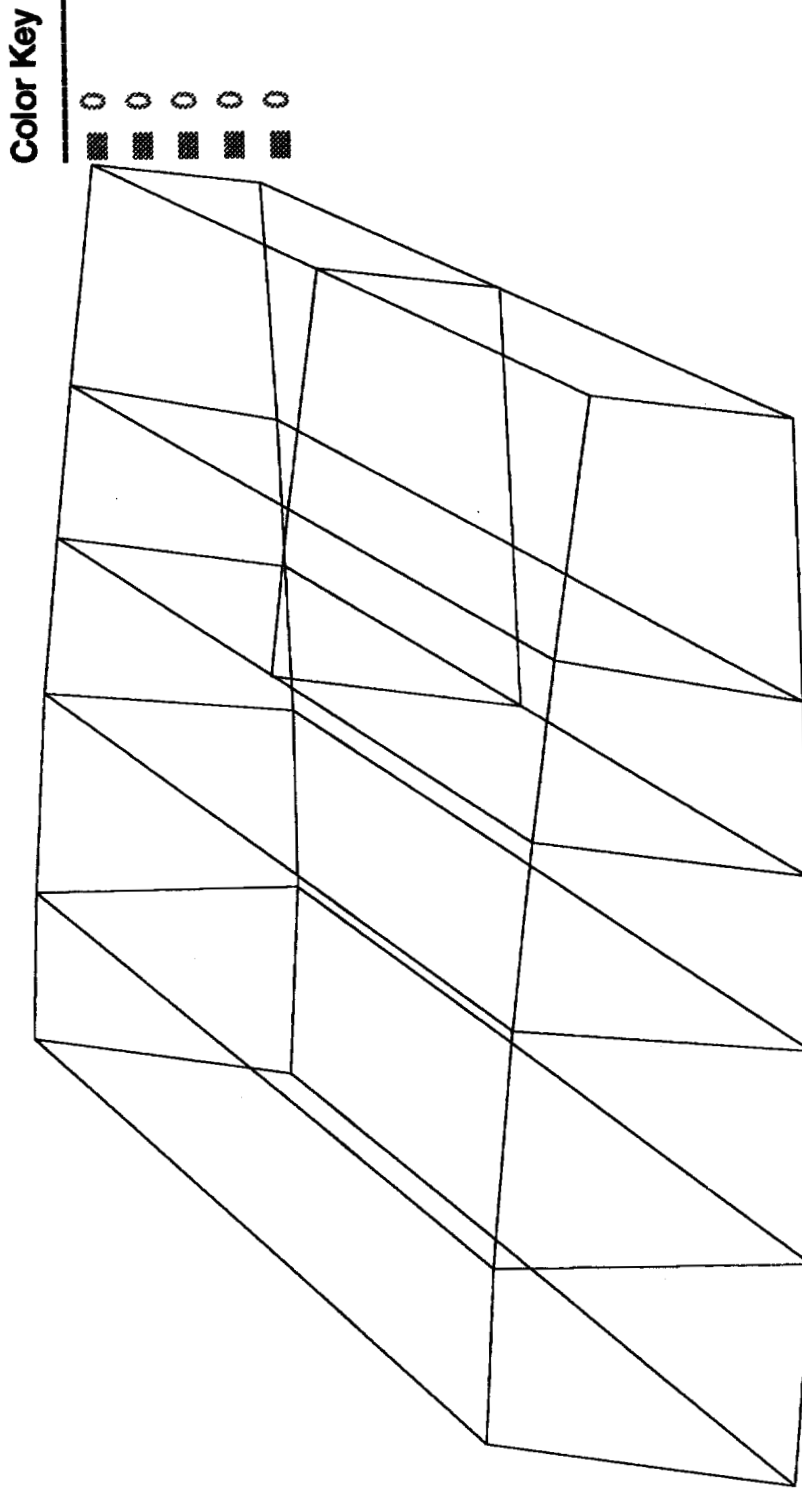

- ① 520-1-650, 2 REQD
- ② 520-1-650, 520-3-650
- ③ 520-1-600, 520-3-600
- ④ 520-1-500, 2 REQ'D
- ⑤ 520-1-500, 520-3-500
- ⑥ 520-1-450, 2 REQ'D
- ⑦ 520-1-450, 520-3-450

NOTES:

A: DO NOT APPLY LUBRICANT TO INSTALL THE ABOVE SEALS.

B: REF DRAWINGS

- PACK No 1
65B40004-1
- PACK No 2
65B40004-2
- PACK No 3
65B40012-1

C: CAUTION: SEE MAINTENANCE MANUAL (36-11-01) FOR IMPORTANT INSTRUCTIONS.

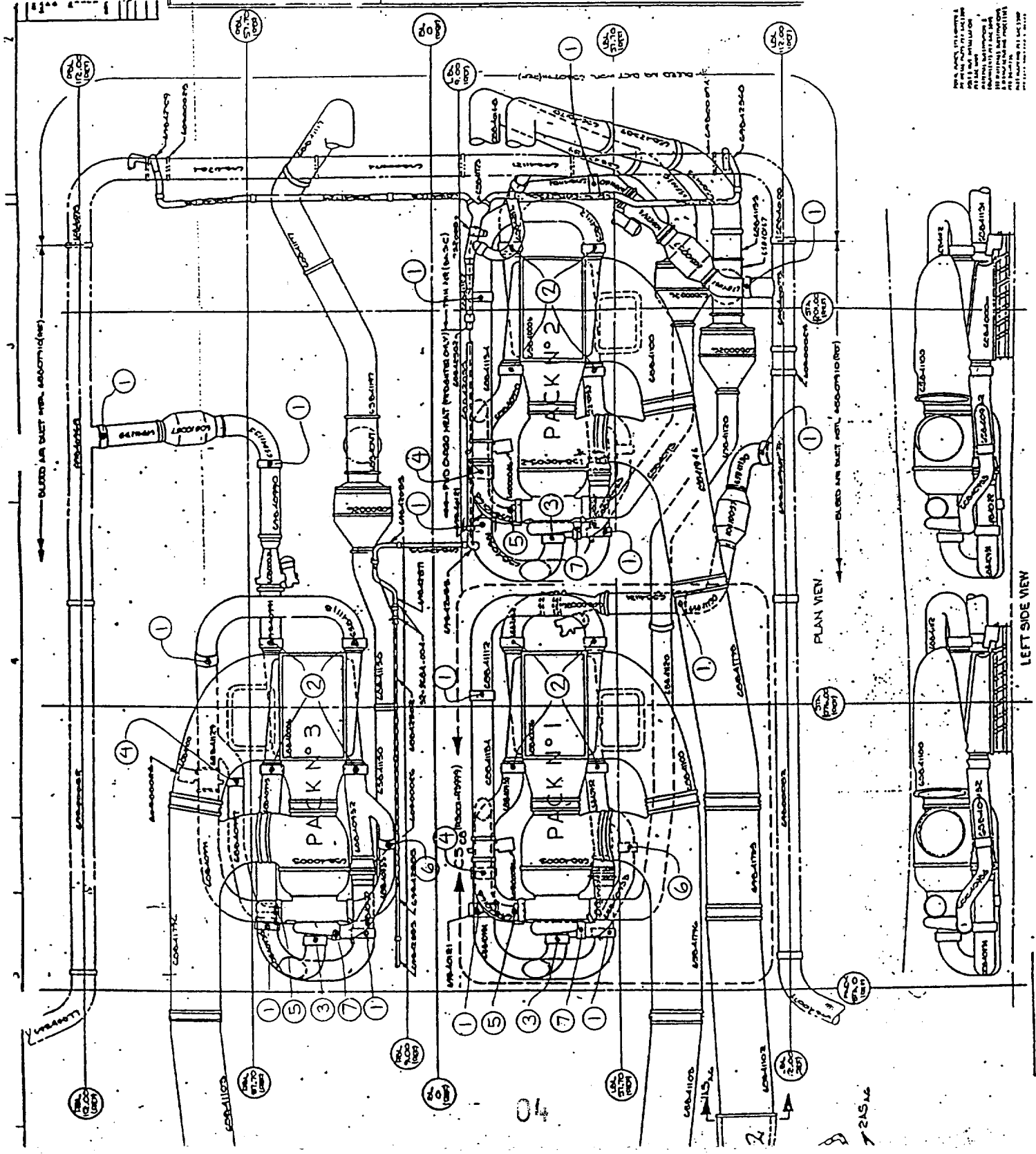

THIS DRAWING IS THE PROPERTY OF THE U.S. GOVERNMENT AND IS LOANED TO YOU BY THE NATIONAL ARCHIVES. IT IS TO BE REPRODUCED AND TRANSMITTED IN ANY FORM AND BY ANY MEANS, ELECTRONIC OR MECHANICAL, INCLUDING PHOTOCOPYING, RECORDING, OR BY ANY INFORMATION STORAGE AND RETRIEVAL SYSTEM, WITHOUT PERMISSION IN WRITING FROM THE NATIONAL ARCHIVES.