

NOTE: ILLUSTRATION SHOWN IS THE BEGINNING POINT FOR FLAP RIGGING. DIMENSIONS AND CHAIN LINK CALLOUTS MAY BE VARIED (BY ONE LINK MAXIMUM) TO ACHIEVE FLAP TRAVEL AND CABLE TENSION SPECIFICATIONS.

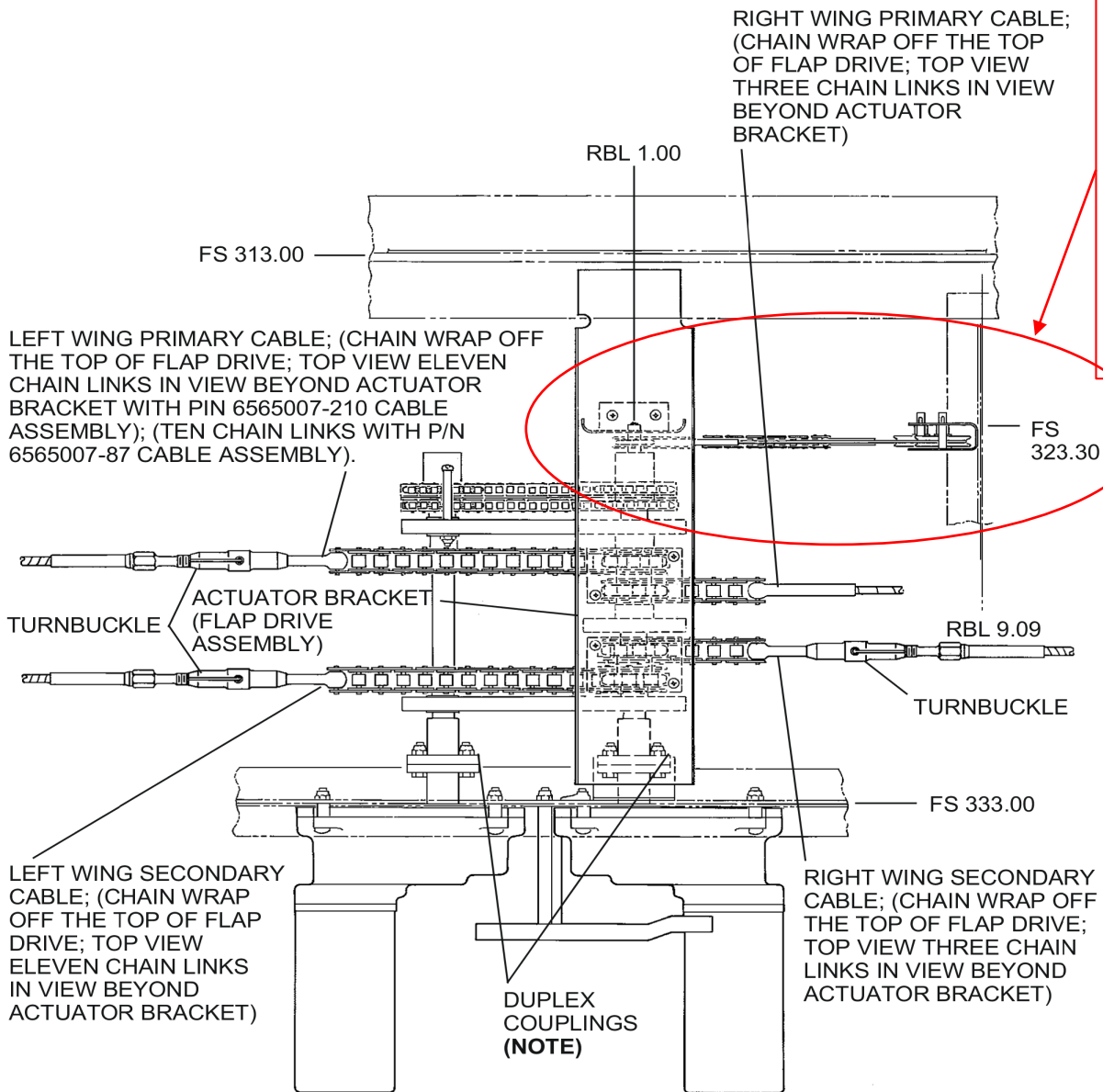
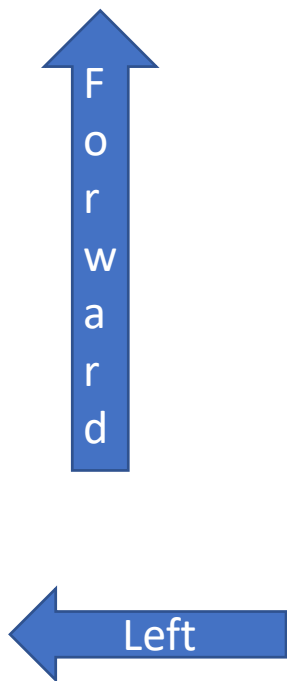

Next page shows flap position based on position of this follow up cable

NOTE: IF 5565175-38 GEARBOX IS INSTALLED, DUPLEX SPROCKETS INSTEAD OF DUPLEX COUPLINGS ARE INSTALLED.

CITATION
Models 500 & 550

Upper cable –
no links showing

Lower cable – more
links showing

FLAP FOLLOW-UP
CABLE POSITIONS

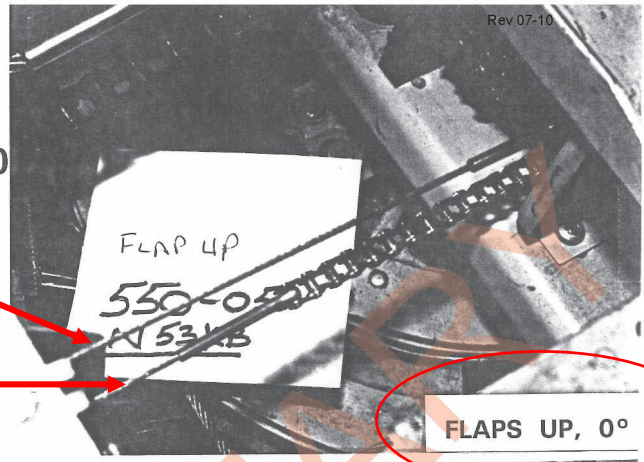

Flap position
based on follow-
up cable

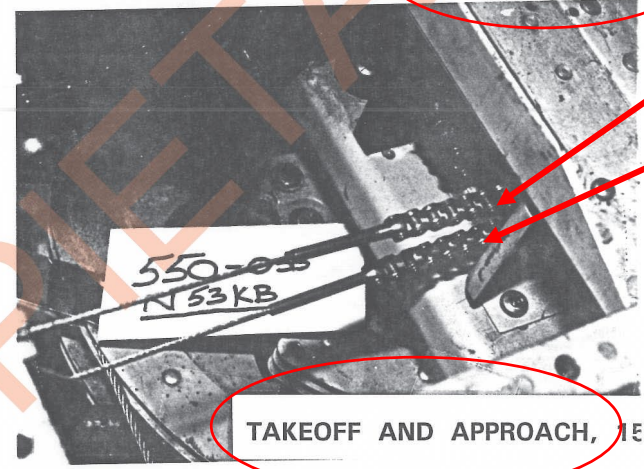
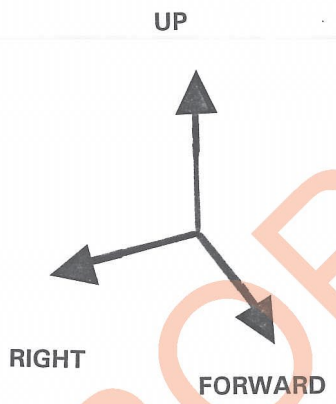

Upper and lower
cables approx.
equal

Upper cable – more
links showing

Lower cable – no
links showing

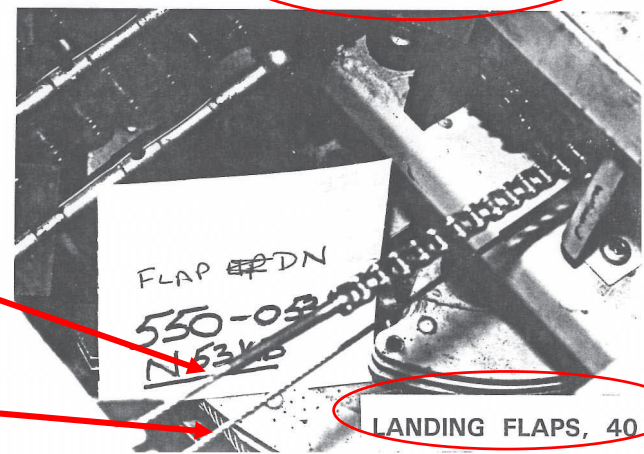

LANDING FLAPS, 40°