

DOCKET NO. **SA- 516**

EXHIBIT NO. **20N**

**NATIONAL TRANSPORTATION SAFETY BOARD
WASHINGTON, D.C**

Boeing 747-100 Center Wing Tank Ground Testing

(72 Pages)

Summary Data Report:
B-747-100 Center Wing Tank Ground Testing
at Marana, AZ

Submitted by:

Joseph Kolly
Office of Research and Engineering
National Transportation Safety Board

January 20, 2000

Abstract

A series of three ground tests was performed on a B747-100 series aircraft. The aircraft was instrumented with sensors located both internal and external to the center wing tank. Thermodynamic measurements (temperature, and heat transfer), liquid fuel samples, and fuel vapor samples were obtained of the center wing tank environment, during full operation of the aircraft's environmental control system. The tests examined the thermodynamic effects of center wing tank fuel load, and thermal insulation of the environmental control system pneumatic ducts, on the center wing tank environment. A data summary report of the thermodynamic measurements, thermal imagery, and fuel headspace and vapor sampling is reported here. Full reports of the headspace GC analysis and center wing tank fuel vapor sampling are reported separately.

Table of Contents

<u>Section</u>	<u>Page</u>
Abstract	i
Table of Contents	ii
List of Figures	iv
List of Tables	vi
List of Appendices	vii
1. Introduction	1
1.1 Test objectives of NTSB	2
1.2 Ground test description	2
2. Instrumentation, measurements, and diagnostics	4
2.1 Data acquisition and reduction	4
2.2 Temperature and heat transfer measurements	4
2.3 Vapor sampling	5
2.4 Fuel sampling	5
2.6 Thermal imagery	5
3. Test results	6
3.1 Test summaries	6
3.1.1 Anomalous ECS operation	6
3.1.2 Test 1 summary	7
3.1.3 Test 2 summary	7
3.1.4 Test 3 summary	7
3.2 Ullage and fuel temperatures	8

3.3 CWT bottom internal surface temperatures	9
3.4 CWT bottom external surface temperatures, RBL58 and LBL58	9
3.5 ECS component temperatures	9
3.6 Vapor sample results	10
3.7 Fuel sample results	12
Appendix A	51

List of Figures

<u>Title</u>	<u>Page</u>
Figure 2.1 CWT internal instrumentation locations.	15
Figure 2.2 CWT internal instrumentation locations.	16
Figure 2.3 CWT internal instrumentation locations.	17
Figure 2.4 CWT external instrumentation locations.	18
Figure 2.5 ECS pack instrumentation.	19
Figure 3.1a Bay 1 ullage temperatures, Test 1.	20
Figure 3.1b Bay 2 ullage temperatures, Test 1.	21
Figure 3.1c Left Mid Bay ullage temperatures, Test 1.	22
Figure 3.1d Right Mid Bay ullage temperatures, Test 1.	23
Figure 3.1e Left Aft Bay ullage temperatures, Test 1.	24
Figure 3.1f Right Aft Bay ullage temperatures, Test 1.	25
Figure 3.2a Bay 1 ullage temperatures, Test 2.	26
Figure 3.2b Bay 2 ullage temperatures, Test 2.	27
Figure 3.2c Left Mid Bay ullage temperatures, Test 2.	28
Figure 3.2d Right Mid Bay ullage temperatures, Test 2.	29
Figure 3.2e Left Aft Bay ullage temperatures, Test 2.	30
Figure 3.2f Right Aft Bay ullage temperatures, Test 2.	31
Figure 3.3a Bay 1 ullage temperatures, Test 3.	32
Figure 3.3b Bay 2 ullage temperatures, Test 3.	33
Figure 3.3c Left Mid Bay ullage temperatures, Test 3.	34

List of Figures, continued

<u>Title</u>	<u>Page</u>
Figure 3.3d Right Mid Bay ullage temperatures, Test 3.	35
Figure 3.3e Left Aft Bay ullage temperatures, Test 3.	36
Figure 3.3f Right Aft Bay ullage temperatures, Test 3.	37
Figure 3.4 Fuel temperatures at 3-inch height, Test 3.	38
Figure 3.5 CWT bottom internal surface temperatures, Test 1.	39
Figure 3.6 CWT bottom internal surface temperatures, Test 2.	40
Figure 3.7 CWT bottom internal surface temperatures, Test 3.	41
Figure 3.8 CWT bottom external surface temperatures, LBL58, Test 1.	42
Figure 3.9 CWT bottom external surface temperatures, LBL58, Test 2.	43
Figure 3.10 CWT bottom external surface temperatures, LBL58, Test 3.	44
Figure 3.11 CWT bottom external surface temperatures, RBL58, Test 1.	45
Figure 3.12 CWT bottom external surface temperatures, RBL58, Test 2.	46
Figure 3.13 CWT bottom external surface temperatures, RBL58, Test 3.	47
Figure 3.14 ECS component temperatures, Test 1.	48
Figure 3.15 ECS component temperatures, Test 2.	49
Figure 3.16 ECS component temperatures, Test 3.	50

List of Tables

<u>Title</u>		<u>Page</u>
Table 1.1	Test matrix for Marana ground test program.	2
Table 3.1	Test 1 summary information.	7
Table 3.2	Test 2 summary information.	7
Table 3.3	Test 3 summary information.	8
Table 3.4	Thermocouple identification.	8
Table 3.5	Vapor sample testing, Test 1.	10
Table 3.6.	Vapor sample testing, Test 3.	11
Table 3.7	Headspace GC results of subsection partial pressure, at 400 kg/m ³ mass loading	13
Table 3.8	Headspace GC results of subsection mole percent, at 400 kg/m ³ mass loading	13
Table 3.9	Headspace GC results of subsection partial pressure, at 3 kg/m ³ mass loading	14
Table 3.10	Headspace GC results of subsection mole percent, at 3 kg/m ³ mass loading	14

List of Appendixes

<u>Appendix</u>	<u>Title</u>	<u>Page</u>
A	Infrared Imaging and Temperature Measurements Under a Boeing 747 Center Wing Tank	51

1. Introduction

On July 17, 1996, at 2031 EDT, a Boeing 747-131, N93119, crashed into the Atlantic Ocean, about 8 miles south of East Moriches, New York, after taking off from John F. Kennedy International Airport (JFK). The airplane was on a regularly scheduled flight to Charles De Gaulle International Airport (CDG), Paris, France, as Trans World Airlines (TWA) Flight 800. The airplane was destroyed by explosion, fire, and impact with the ocean. All 230 people aboard were killed.

In support of the investigation into this accident, the NTSB has conducted research and tests of the thermal environment and flammability exposure of the B-747 aircraft's center wing tank (CWT). A flight test conducted in 1997 by the NTSB measured the thermodynamic conditions of the CWT environment during various phases of aircraft operation.¹ These tests showed that substantial heat is transferred to the CWT by the operation of the aircraft's environmental control system (ECS), resulting in the generation of flammable conditions within the CWT under certain operating conditions. These results were not identified by previous research, suggesting the lack of a detailed understanding of the complex nature of the thermodynamics of the CWT environment. It was therefore considered essential to acquire additional fundamental data of this thermochemical environment.

Following the flight tests, Boeing conducted a series of ground tests aboard a B-747-100 aircraft. Boeing's objectives for these tests were stated in their Engineering Work Authorization as: 1) To determine the effectiveness of insulation on pneumatic ducts (of the Environmental Control System (ECS)) under ground operating conditions, and 2) to determine the effect of suppressor circuits on Fuel Quantity Indication System (FQIS) operation.

These tests made similar thermodynamic measurements of the CWT environment as employed in the previous NTSB flight test program. Consequently, the NTSB took the opportunity during Boeing's ground tests to make additional measurements, to compliment the flight test data. A cooperative agreement was reached to allow test data and results to be shared between the NTSB and Boeing.

This report describes a summary of the thermodynamic data acquired during testing. A summary of the fuel vapor samples is also included. Information regarding the electrical/electronic issues of FQIS operation is not included in this report. Headspace GC analysis of the fuel and a report of the full vapor sample analysis are reported separately.

¹ National Transportation Safety Board. 1997. *Flight Test Group Chairman's Factual Report of Investigation*, Trans World Airlines Flight 800, East Moriches, New York, July 17, 1996. NTSB docket No. SA-516, exhibit No. 23A. Washington, DC.

1.1 Test objectives of NTSB

These tests were conducted by Boeing for internal research purposes, whose objectives are stated in the previous section.² The objectives of the NTSB participation are more general to the issues of the thermochemical environment of the CWT. These objectives were to obtain measurements of the environmental conditions in and around the CWT during operating conditions that cause significant heating of the CWT. Specifically, to investigate the effects that fuel load and thermal insulation have on the thermochemistry of the CWT. These factors have been identified in NTSB Safety Recommendations A-96-174 and A-96-175 as areas to be considered to reduce CWT flammability.

1.2 Ground test description

On May 29-31, 1998, a series of three ground tests was performed on a 747-100 series aircraft by The Boeing Company. Boeing leased the aircraft from Evergreen Aircraft Company, and conducted the tests at Evergreen's facilities at the Pinal Air Park in Marana, AZ. These tests were limited to ground operations only.

The testing was performed on a stationary aircraft, parked on the tarmac at the Air Park. The aircraft orientation was 0.5 degrees nose down pitch, and approximately zero degrees roll. The main wing tanks were filled to capacity with Jet-A fuel several days in advance of the tests, and remained full throughout the test series. The aircraft's Auxiliary Power Unit (APU) was operated to provide the power to the aircraft, and to run the ECS system. Each of the three tests had all three ECS packs operational for the entire duration of each three-hour test. The effects of CWT fuel load, and ECS duct insulation on the CWT thermal environment were examined. A test matrix of these three tests is shown in Table 1.1.

Test No.	Date	CWT Fuel Load	Duct Insulation	Vapor Sampling
1	29 MAY 98	50 gallons	No	Yes
2	30 MAY 98	50 gallons	Yes	No
3	31 MAY 98	12,000 pounds	No	Yes

Table 1.1. Test matrix for Marana ground test program.

The configuration for Test 1 replicated the fuel load and preflight hold period of Flight 800. The CWT contained approximately 50 gallons of Jet-A fuel. The test

²Boeing Company. 1998. *ECS Duct Insulation Ground Test and 12,000 Pound Fuel Loading Test*. Boeing Test B3.10.0717, Evergreen Air Center, Marana, AZ, May 19-31, 1998. Seattle, WA.

duration was approximately three hours. All three ECS packs were operating on full cold. Test 1 also served as a baseline test that the remaining tests were compared to.

Test 2 was designed to assess the effectiveness of ECS duct insulation to reduce CWT temperatures. The test conditions were the same as those of Test 1, except for the addition of duct insulation. The insulation used was a fiberglass blanket, approximately ½-inch thick matting, wrapped around the ducting of each ECS pack. Further details of the insulation and its installation can be obtained from Boeing (see also Boeing 1998.).

Test 3 was designed to investigate the effectiveness of added fuel load in the CWT to reduce heat transfer from the ECS components to the CWT, thereby reducing fuel temperatures. Test conditions were the same as those for Test 1, except for an increase in CWT fuel load to 12,000 pounds of Jet-A.

2. Instrumentation, measurements, and diagnostics

The Boeing Company provided the technical staff to conduct these tests. They supplied and installed the bulk of the instrumentation and the data acquisition system. The instrumentation was placed throughout the ECS pack bay and center wing tank (CWT) regions of the aircraft. This instrumentation consisted primarily of thermocouples to measure surface and localized ambient temperatures. Total and radiative heat transfer gages were supplied by NTSB, and installed on the bottom exterior of the CWT. Vapor sampling ports were installed internal to each CWT bay and connected to the sample canister station constructed outside the aircraft.

Much of the instrumentation and sampling ports duplicated that used in the previous NTSB flight tests. In general, additional instrumentation and sampling ports were installed to increase the resolution that was provided by the flight test measurements.

2.1 Data acquisition and reduction

The data acquisition system used was a Loral Portable Airborne Digital Data System (PADDS II). The PADDS II unit consisted of an analog to digital converter, Remote Multiplex Unit (RMUX), and the Central Multiplex Unit (CMUX). The amplified and conditioned signals were stored on a standard PC computer. The data were sampled at one Hertz, over the entire testing interval, from approximately 15 minutes prior to ECS start, to 30 minutes after ECS shutdown. Details of the acquisition system and the data reduction can be obtained from Boeing.

2.2 Temperature and heat transfer measurements

All temperature measurements were made with Type E thermocouples. Thermocouples were used to acquire surface temperature measurements of the interior surfaces of the CWT. Thermocouples were also positioned free from the interior surface, to acquire ullage, or fuel ambient, temperatures. The locations and identification of these thermocouples are shown in Figures 2.1–2.3. Exterior to the CWT, 97 thermocouples were used to measure its bottom surface temperatures and the ambient temperatures within the pack bay. The locations and identification of these thermocouples are shown in Figure 2.4. The surface temperatures of various ECS components were also measured. 38 thermocouples were located at the component locations shown in Figure 2.5.

Total heat transfer and radiation heat transfer gages were installed on the bottom exterior CWT surface within the pack bay. These gages locations are shown in Figure 2.5. However, due to technical difficulties, valid measurements were not obtained from these instruments, and are not included in this report.

2.3 Vapor sampling

Vapor samples of the ullage in each bay of the CWT were obtained during the first and third test. These samples were drawn near the middle of the volume of each bay, and at three different heights in Bay 2. The eight sample port locations are shown in Figure 2.3.

The sampling port lines consisted of 1/8-inch OD copper tubing. These lines were run from the aircraft's CWT bays, through the CWT dry bay, out the dry bay access panel, out the cargo door, and to the sampling station located on the ground outside the aircraft. The lines were heated to 160 degrees F by controlled electric resistance heaters, from their emergence of the dry bay, to the sample bottles at the sampling station. At the sampling station, each line was fitted to its own one liter stainless steel sample bottle. The tubing and shut-off valves were plumbed in such a way as to permit flushing of the entire length of each sample line simultaneously, by a pump drawing vapor from the CWT past each bottle prior to sampling. During sampling, the pump was isolated and the evacuated bottles filled via pressure differential. Shut-off valves permit easy installation and removal of sample bottles.

The samples were analyzed Desert Research Inc. for chemical composition and fuel-air ratio.³ The results are summarized in Section 3.6.

2.4 Fuel sampling

Fuel samples were taken of the CWT fuel from Tests 1 and 3. The headspace of the fuel was analyzed by gas chromatography for chemical composition at the University of Nevada.⁴ The results are summarized in Section 3.7.

2.5 Thermal imagery

Thermal imagery of the ECS pack bay exterior and interior components was acquired immediately following Test 3. Video and digital still images were recorded, and the corresponding surface temperature of each object was measured independently with a hand held thermocouple temperature meter.

This effort was undertaken as a separate task by the California Institute of Technology, under contract to NTSB. The complete report of this task is included in Appendix A. For details of these measurements and results obtained, the reader is referred to this appendix.

³ Sagebiel, John C. 1998. *Sampling and Analysis of Vapors from the Center Wing Tank of a Boeing 747-100 Aircraft During Ground Tests*, Draft Final Report, Energy and Environmental Engineering Center, Desert Research Institute, University of Nevada, Reno, NV.

⁴ Woodrow, James E. 2000 *The Laboratory Characterization of Jet A Fuel with various Flashpoints*, to be submitted by the Center for Environmental Sciences and Engineering, University of Nevada at Reno.

3. Test results

This section displays a summary of a selected subset of data channels of each test in graphical form. The data shown are subsampled at 15 minute intervals, time averaged over a one minute interval. Representation of the data in this form describes the general thermodynamic behavior of the CWT environment in these tests. A complete database of every thermocouple measurement taken for each test is a part of the accident docket. The archive files contains one Hertz data of each channel for a record length of approximately 3.5 hours, for each test.

3.1 Test summaries

Each test is summarized in the following sections. Further details of each test are recorded as field notes on record at Boeing.

3.1.1 Anomalous ECS operation

Anomalies in ECS operation were experienced during these tests. One example are the numerous ECS pneumatic duct leaks. Efforts were made to repair these leaks, but due to program constraints they could not be totally eliminated. Anecdotal observations by Boeing technicians indicated that the leaks that remained in the ECS system could be considered similar to those found in normal operation of a similarly aged aircraft. Another example is that ECS pack 2 was operating at less than full operation due to a stuck turbine bypass valve. Further detail is provided below.

Supply side leaks of hot air were noted at various locations in the ducts throughout the aircraft's pack bay. These occurred at the joints and seals of the ducts, and measures were taken by Boeing to repair and eliminate the most severe leaks. Some were not eliminated, some evolved during testing, and some were not detected until after testing was completed.

On the conditioned side, significant leaks of cold conditioned air were determined to have occurred on the ducting above the CWT, beneath the cargo bay flooring. This was evidenced by the leakage of cool air through the cargo bay floor during the test. Repairs to this area could not be made during this test program.

The turbine bypass valve of ECS pack 2 was stuck in the 25% open position throughout the tests. A shortage of spare parts and test scheduling constraints mandated that the tests be performed in this mode of ECS pack 2 operation. This condition was kept constant for all three tests.

There was no indication that the leak rates or percent of turbine bypass had changed appreciably from test to test. Boeing attributed the cause of these problems to the age of the aircraft components.

3.1.2 Test 1 summary

The CWT contained approximately 50 gallons of Jet-A fuel. Boeing estimates this fuel to have pooled to the starboard side of Bay 1 and 2 – a result of the aircraft's nosedown pitch and incidental roll attitude caused by under inflated right main landing gear. All three ECS packs were operated on full cold condition for 3 hours and 6 minutes. The turbine bypass valve for pack 2 was stuck in the 25% open position throughout the test. Identifying information for Test 1 is provided in Table 3.1.

Test	Date	ECS Start Time	ECS End Time	CWT Fuel Load	Fuel Flashpoint (°F)	Ambient Temperature (°F)	Comments
1	29May98	14:46 PST	17:52 PST	50 gallons	123	92 at start	Baseline condition

Table 3.1. Test 1 summary information.

3.1.3 Test 2 summary

The test parameters were kept the same as that for Test 1 (fuel load, ECS operation, aircraft position, etc.) except for the addition of duct insulation. The insulation used was a fiberglass blanket with approximately ½-inch thick matting. This is the same type used to insulate the Auxiliary Power Unit (APU) ducts in the B-777, 767, and 757 aircraft. These blankets were wrapped around the pneumatic ducting of each pack of the ECS also in a similar technique to that used in the APU duct installation. Boeing estimates this coverage at 80 percent of the total airpath within the pack bay, from the supply duct (hottest air temperature) to the turbine output (coolest air temperature). All three ECS packs were operated on full cold condition for 3 hours and 7 minutes. The turbine bypass valve for pack 2 was stuck in the 25% open position throughout the test. Identifying information for Test 2 is provided in Table 3.2.

Test	Date	ECS Start Time	ECS End Time	CWT Fuel Load	Fuel Flashpoint (°F)	Ambient Temperature Range (°F)	Comments
2	30May98	14:57 PST	18:04 PST	50 gallons	123	97-107	ECS ducts insulated

Table 3.2. Test 2 summary information.

3.1.4 Test 3 summary

12,000 lbs. of 74 degree F Jet A fuel were loaded into the CWT approximately 3.5 hours before the start of testing. Shortly after the fuel was loaded, the fuel temperature stabilized to 79 degrees F in the CWT. The depth of fuel in the CWT was estimated by

Boeing to be 12 inches at Spanwise Beam 3, and 6 inches at the Rear Spar. The average depth over approximately 75% of the tank was estimated to be 10 inches. This was calculated by Boeing post test, using engineering drawings of the CWT oriented to the aircraft's attitude during the test. Lateral (port-starboard) variations in depth were considered insignificant. All three ECS packs were operated on full cold condition for 3 hours and 7 minutes. The turbine bypass valve for pack 2 was stuck in the 25% open position throughout the test. Identifying information for Test 2 is provided in Table 3.3.

Test	Date	ECS Start Time	ECS End Time	CWT Fuel Load	Fuel Flashpoint (°F)	Ambient Temperature Range (°F)	Comments
3	31May98	13:06 PST	16:13 PST	12,000 lbs.	123	98-105	Fuel addition test

Table 3.3. Test 3 summary information.

3.2 Ullage and fuel temperatures

Time histories of the ullage and fuel temperatures of each CWT bay are shown for Test 1 in Figures 3.1a-f. Three measurement locations are shown for each bay to illustrate the bulk stratification of temperatures within each bay. These selected thermocouple locations are centered laterally (port-starboard) and longitudinally (fore-aft) in each bay, at three elevations. The exception is the top thermocouple locations for Bays 1 and 2, where an off-center gage was selected (due to malfunction of the center gage). The identification of gages used for these plots is given in Table 3.4. These identifiers can be located on the instrumentation layout drawings, Figures 2.1-2.3.

Similar temperature - time histories for Test 2 and Test 3 are shown in Figures 3.2a-f and 3.3a-f, respectively.

	3" up from bottom	Middle	3" down from top
Bay 1	6170329	6170274	6170281
Bay 2	6170339	6170277	6170287
Left Mid Bay	6170291	6170292	6170293
Right Mid Bay	6170294	6170295	6170296
Left Aft Bay	6170297	6170298	6170299
Right Aft Bay	6170300	6170301	6170302

Table 3.4. Thermocouple identification.

The temperature of the fuel during Test 3 could be monitored by the thermocouple gages listed as the Bottom gages in Table 3.4, since they were submerged by the fuel. The time histories of the fuel temperature of each bay, 3 inches above the CWT bottom, are shown in Figure 3.4.

3.3 CWT bottom internal surface temperatures

Figure 3.5 shows the time history of temperatures of several surface mounted thermocouples, for Test 1. Each measurement location is at the center of the bottom internal surface of each CWT bay. The times shown are referenced to elapsed time of ECS operation. The abscissa is divided into bins, one for each CWT bay. Figure 3.6 and 3.7 are the same type of measurement for Test 2 and Test 3, respectively.

Because the exact location of the pool of fuel was not known in Tests 1 and 2, it is uncertain if the thermocouples in these tests were in contact with the fuel. They were certainly submerged in each bay during Test 3, on the basis of the fuel depth estimated by Boeing.

3.4 CWT bottom external surface temperatures, RBL58 and LBL58

Figure 3.8 shows the time evolution of temperatures of the CWT bottom exterior surface at discrete locations right butt line 58 (RBL58). Figure 2.4 illustrates the positioning of the measurement locations. The abscissa of the plot indicates the corresponding CWT bay that is located above the measurement location. The times shown are referenced to elapsed time of ECS operation. Figure 3.9 and 3.10 are the same measurements for Test 2 and Test 3, respectively.

Figures 3.11 - 3.13 are similar measurements to those of the previous figures, with the exception that these measurements are located along the left butt line 58. These figures are shown for Test 1 - 3, respectively.

3.5 ECS component temperatures

Figures 3.14 - 3.16 illustrate the steady state operating temperatures of the exterior surface of certain ducts and components of the ECS packs, following 3 hours of ECS operation. Temperatures are presented from left to right, in order of the airflow (from APU to cabin) as follows: The first is the aft bleed duct; next the inlet to the primary heat exchanger; next the outlet to the primary heat exchanger; next the compressor output duct; next the secondary heat exchanger outlet; and finally the water separator.

3.6 Vapor sample results

Vapor samples of the CWT ullage space were taken during Test 1 and Test 3. For further details of the analytic methods and the results obtained for both tests, the reader is referred to (Sagebiel 1998).

During Test 1, samples were taken at the 1, 2, and 3 hour mark of elapsed time of ECS operation. A summary of the results of the vapor sample analysis for Test 1 is shown in Table 3.5. The temperature location associated with each fuel vapor sample is identified in the chart. Fuel/air mass ratios have been calculated for each sample.

Sample location	Sample time (elapsed)	Corresponding temperature location	Temperature (°F)	F/A mass ratio
Bay 1	1 hr	Bay 1 bottom internal surface. temperature (center)	117.5	0.037
	2 hr		136.4	0.044
	3 hr		142.4	0.045
Bay 2 lower	1 hr	Bay 2 bottom internal surface. temperature (center)	138.7	0.033
	2 hr		154.6	0.036
	3 hr		158.1	0.039
Bay 2 mid	1 hr	Bay 2 bottom internal surface. temperature (center)	138.7	0.035
	2 hr		154.6	0.036
	3 hr		158.1	0.040
Bay 2 upper	1 hr	Bay 2 bottom internal surface. temperature (center)	138.7	0.033
	2 hr		154.6	0.037
	3 hr		158.1	0.041
Left Mid	1 hr	Left Mid Bay bottom internal surface. temperature (center)	134.2	0.028
	2 hr		145.7	0.031
	3 hr		148.7	0.033
Right Mid	1 hr	Right Mid Bay bottom internal surface. temperature (center)	125.8	0.029
	2 hr		138.3	0.030
	3 hr		141.6	0.035
Left Aft	1 hr	Left Aft Bay bottom internal surface. temperature (center)	140.3	0.031
	2 hr		152.6	0.032
	3 hr		154.3	0.033
Right Aft	1 hr	Right Aft Bay bottom internal surface. temperature (center)	121.4	0.042
	2 hr		133.9	0.032
	3 hr		138.0	0.040

Table 3.5. Vapor sample testing, Test 1.

During Test 3, samples were taken at the 3 hour mark of elapsed time of ECS operation. A summary of the results of the vapor sample analysis for Test 3 is shown in Table 3.6. The temperature location associated with each fuel vapor sample is identified in the chart. Fuel/air mass ratios have been calculated for each sample.

Sample location	Sample time (elapsed)	Corresponding temperature location	Temperature (°F)	F/A mass ratio
Bay 1	3 hr	Bay 1 amb. Fuel Temp 3-inches above bottom surface (center)	103.8	0.034
Bay 2 l	3 hr	Bay 2 amb. Fuel Temp 3-inches above bottom surface (center)	107.1	0.035
Bay 2 m	3 hr		107.1	0.032
Bay 2 u	3 hr		107.1	0.034
Left Mid	3 hr	Left Mid amb. Fuel Temp 3-inches above bottom surface (center)	115.2	0.039
Right Mid	3 hr	Right Mid amb. Fuel Temp 3-inches above bottom surface (center)	110.6	0.039
Left Aft	3 hr	Left Aft amb. Fuel Temp 3-inches above bottom surface (center)	120.2	0.043
Right Aft	3 hr	Right Aft amb. Fuel Temp 3-inches above bottom surface (center)	114.9	0.041

Table 3.6. Vapor sample testing, Test 3.

3.7 Fuel sample results

Headspace GC analysis of the Jet A fuel used in Test 1 and 3 were performed at the University of Nevada at Reno. Two mass loadings were analyzed. The 400 kg/m³ condition corresponds to a fully saturated vapor condition (which results from an approximately half full tank). The 3kg/m³ condition corresponds to a near empty fuel tank, represented by 50 gallons of fuel in the CWT. Three fuel temperatures, at 40, 50 and 60 degrees Celsius, were analyzed for each sample and mass loading combination. A summary of these results are presented below in Tables 3.7 - 3.10.

The partial pressure and mole percent of each carbon subsections C5 through C12 are shown in the following tables. The reader is referred to (Woodrow 2000) for a detailed explanation of the analysis and results.

Half-filled Tank (~400 kg/m³).

		Subsection Partial Pressure								
		(mbar)								
Temperature	Fuel	5	6	7	8	9	10	11	12	Total
40°C	Test #1	0.462	0.286	0.871	1.60	1.83	1.18	0.461	0.142	6.83±0.17
40°C	Test #3	0.492	0.301	0.876	1.55	1.78	1.18	0.476	0.135	6.79±0.09
50°C	Test #1	0.608	0.407	1.36	2.66	3.14	2.02	0.805	0.209	11.2±0.3
50°C	Test #3	0.639	0.437	1.39	2.60	3.06	2.02	0.807	0.205	11.2±0.1
60°C	Test #1	0.731	0.542	1.90	3.89	4.80	3.07	1.38	0.344	16.6±0.1
60°C	Test #3	0.772	0.583	1.96	3.86	4.76	3.28	1.34	0.360	16.9±0.2

Table 3.7 Headspace GC results of subsection partial pressure,
at 400 kg/m³ mass loading

		Subsection Mole Percent in Vapor:								
		Average								
Temperature	Fuel	5	6	7	8	9	10	11	12	MW
40°C	Test #1	6.76	4.19	12.7	23.4	26.8	17.3	6.75	2.08	121.0
40°C	Test #3	7.24	4.43	12.9	22.8	26.2	17.4	7.01	1.99	120.7
50°C	Test #1	5.42	3.63	12.1	23.7	28.0	18.0	7.18	1.86	122.3
50°C	Test #3	5.73	3.92	12.4	23.3	27.4	18.1	7.23	1.84	122.0
60°C	Test #1	4.39	3.25	11.4	23.4	28.8	18.4	8.28	2.06	123.7
60°C	Test #3	4.56	3.45	11.6	22.8	28.1	19.4	7.92	2.13	123.6

Table 3.8 Headspace GC results of subsection mole percent,
at 400 kg/m³ mass loading

Nominal Loading (~3 kg/m³).

		Subsection Partial Pressure									
		(mbar)									
Temperature	Fuel	5	6	7	8	9	10	11	12	Total	
40°C	Test #1	0.069	0.132	0.570	1.22	1.49	1.01	0.425	0.146	5.06±0.20	
40°C	Test #3	0.077	0.142	0.590	1.22	1.48	1.05	0.456	0.144	5.16±0.04	
50°C	Test #1	0.083	0.156	0.851	2.03	2.59	1.74	0.721	0.182	8.35±0.21	
50°C	Test #3	0.087	0.172	0.877	2.01	2.57	1.78	0.745	0.198	8.44±0.09	
60°C	Test #1	0.093	0.174	1.08	2.86	3.97	2.84	1.19	0.343	12.6±0.2	
60°C	Test #3	0.088	0.192	1.16	2.84	3.97	2.96	1.34	0.410	13.0±0.3	

Table 3.9 Headspace GC results of subsection partial pressure,
at 3 kg/m³ mass loading

		Subsection Mole Percent in Vapor:									
											Average
Temperature	Fuel	5	6	7	8	9	10	11	12	MW	
40°C	Test #1	1.36	2.61	11.3	24.1	29.4	20.0	8.40	2.88	126.2	
40°C	Test #3	1.49	2.75	11.4	23.6	28.7	20.4	8.84	2.79	126.2	
50°C	Test #1	0.994	1.87	10.2	24.3	31.0	20.8	8.63	2.18	126.9	
50°C	Test #3	1.03	2.04	10.4	23.8	30.4	21.1	8.83	2.35	127.0	
60°C	Test #1	0.741	1.39	8.60	22.8	31.6	22.6	9.48	2.73	128.6	
60°C	Test #3	0.679	1.48	8.95	21.9	30.6	22.8	10.3	3.16	129.1	

Table 3.10 Headspace GC results of subsection mole percent,
at 3 kg/m³ mass loading

Appendix A

Infrared Imaging and Temperature Measurements
Under a Boeing 747 Center Wing Tank

**NTSB CWT INSTRUMENTATION
FROM PREVIOUS NTSB
747-100 TESTING***

*6170332 through 336 and 322 through 326 have been deleted. Other boundary conditions were also deleted due to duplications with Figure 3. All T/C have 6170 prefix unless otherwise stated

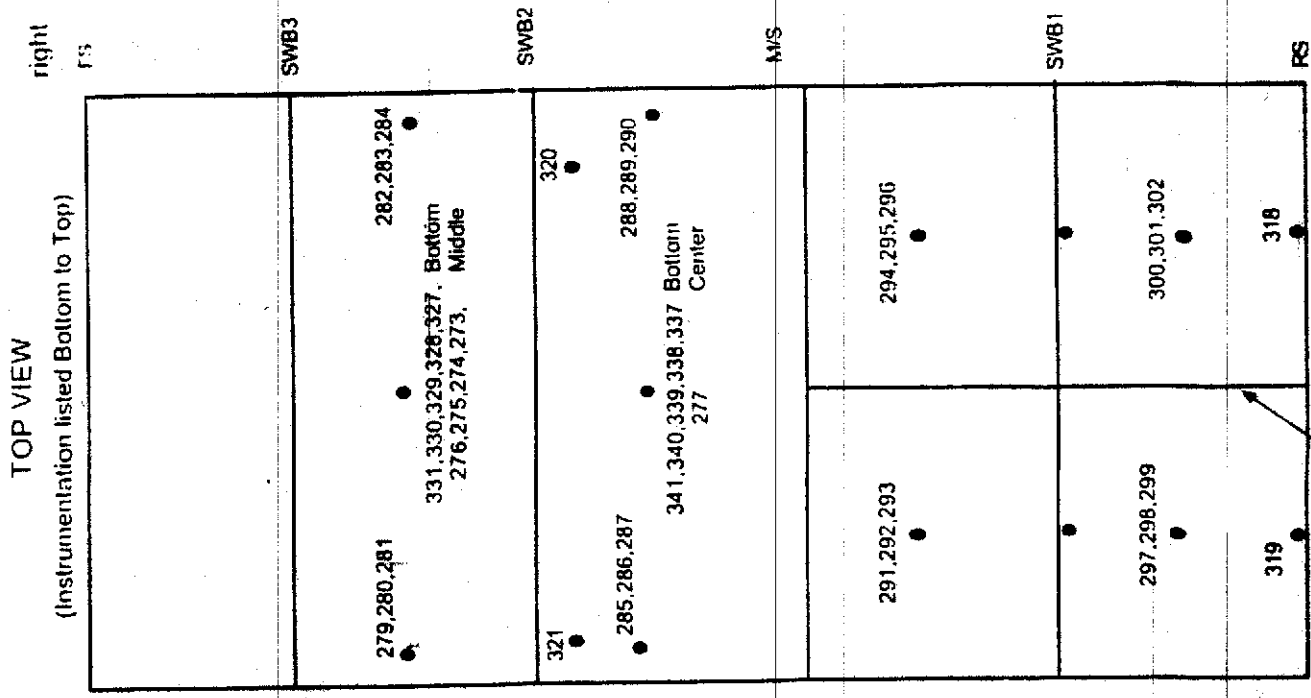
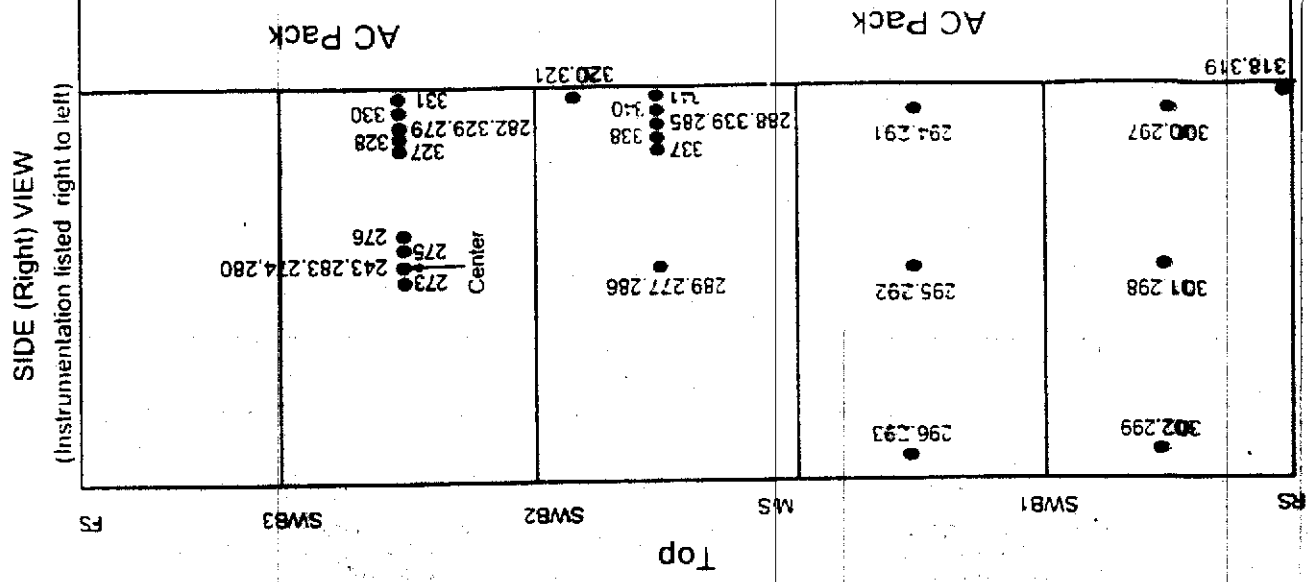

REAR VIEW

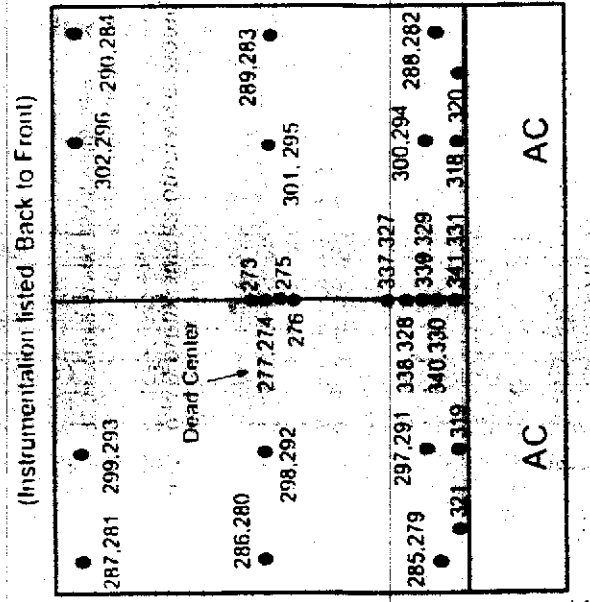

Partial Rib BLO

Figure 2.1 CWT internal instrumentation locations.

Drawing Not To Scale - For Reference Only

**CWT INSTRUMENTATION
FOR ECS DUCT INSULATION
GROUND TEST**

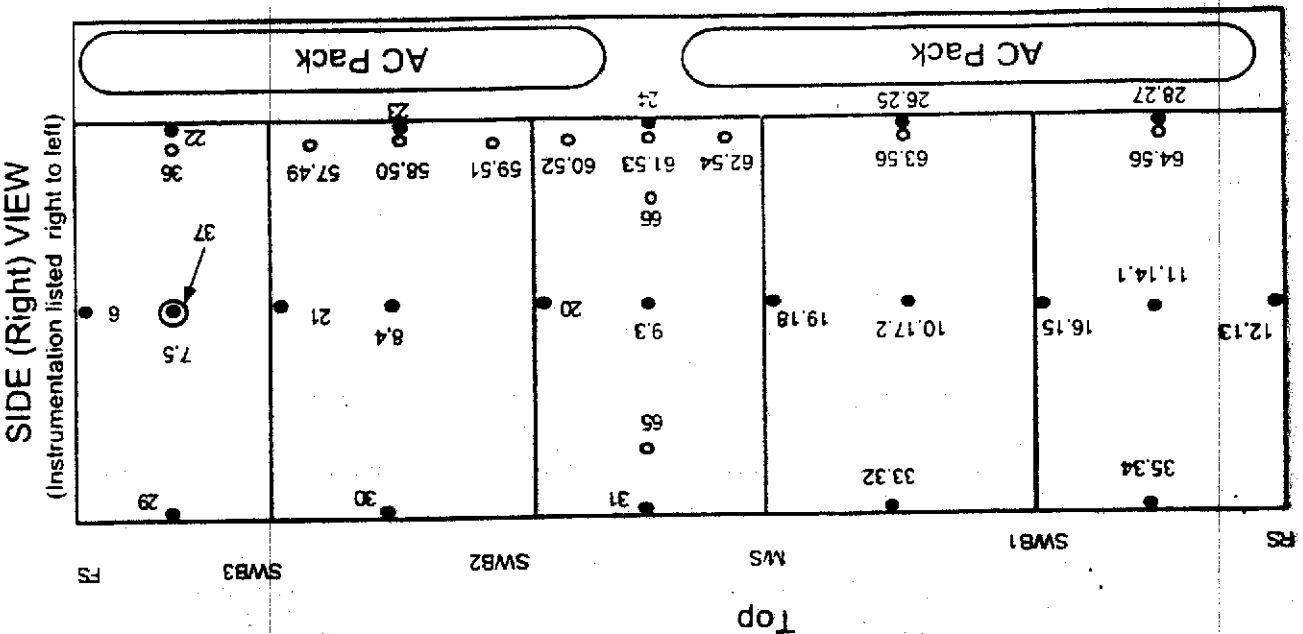
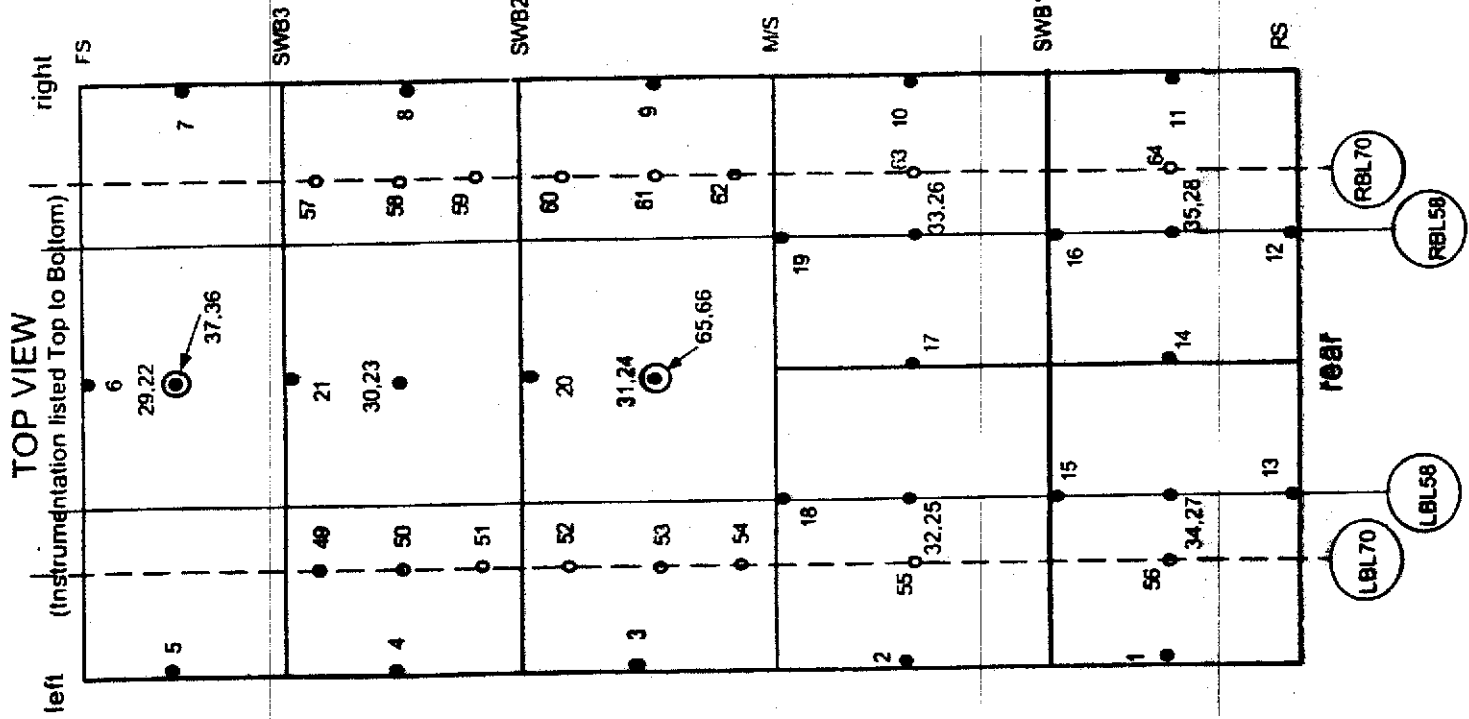
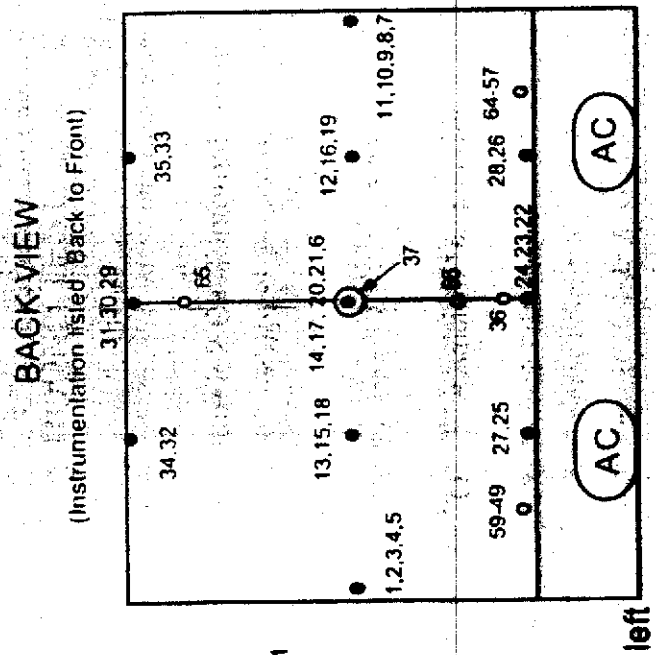

Figure 2.2 CWT internal instrumentation locations.

- = Ambient Temperature
- = Surface Temperature



Drawing Not To Scale

TOP VIEW
(Thermocouples are listed top to bottom)

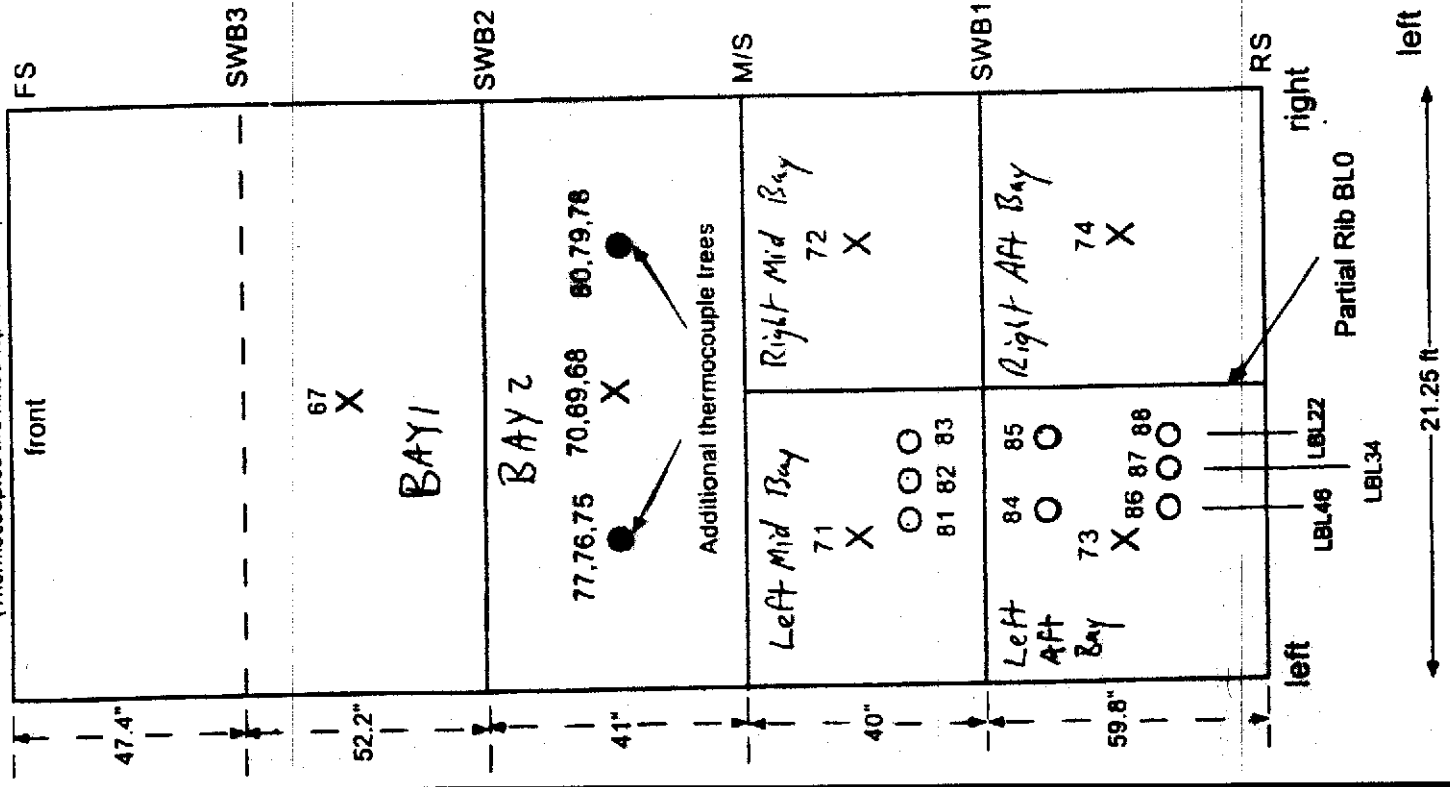

SIDE (Right) VIEW
(Thermocouples are listed right to left.)

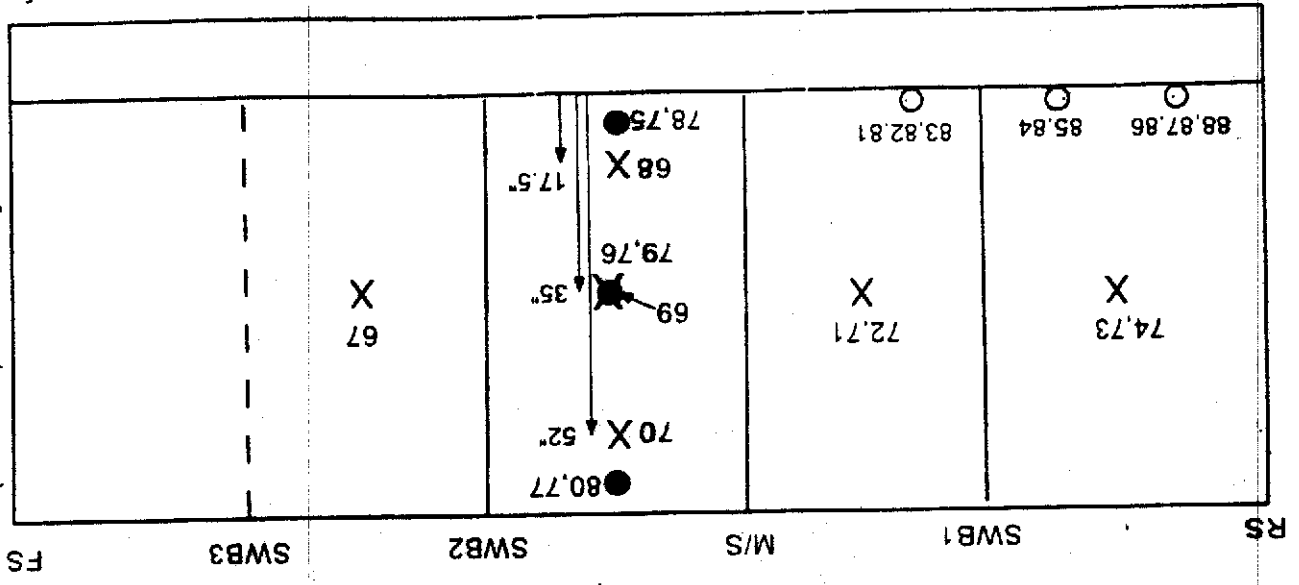

747 INTERNAL CWT INSTRUMENTATION ECS DUCT INSULATION GROUND TEST

Figure 2.3 CWT internal instrumentation locations.

- X = Vapor Sampling Probe Locations
- = Ambient Temperature Thermocouple Trees
- = Surface Temperature Thermocouples

REAR VIEW
(Thermocouples are listed back to front)

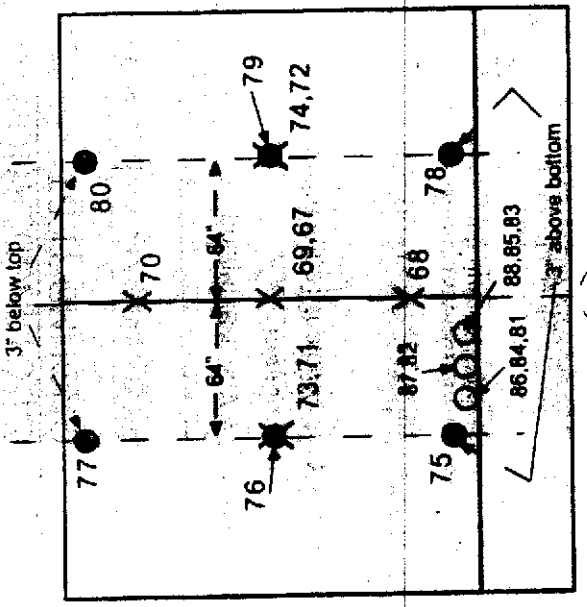

747-100 PACK BAY INSTRUMENTATION (CWT LOWER PANEL ONLY)

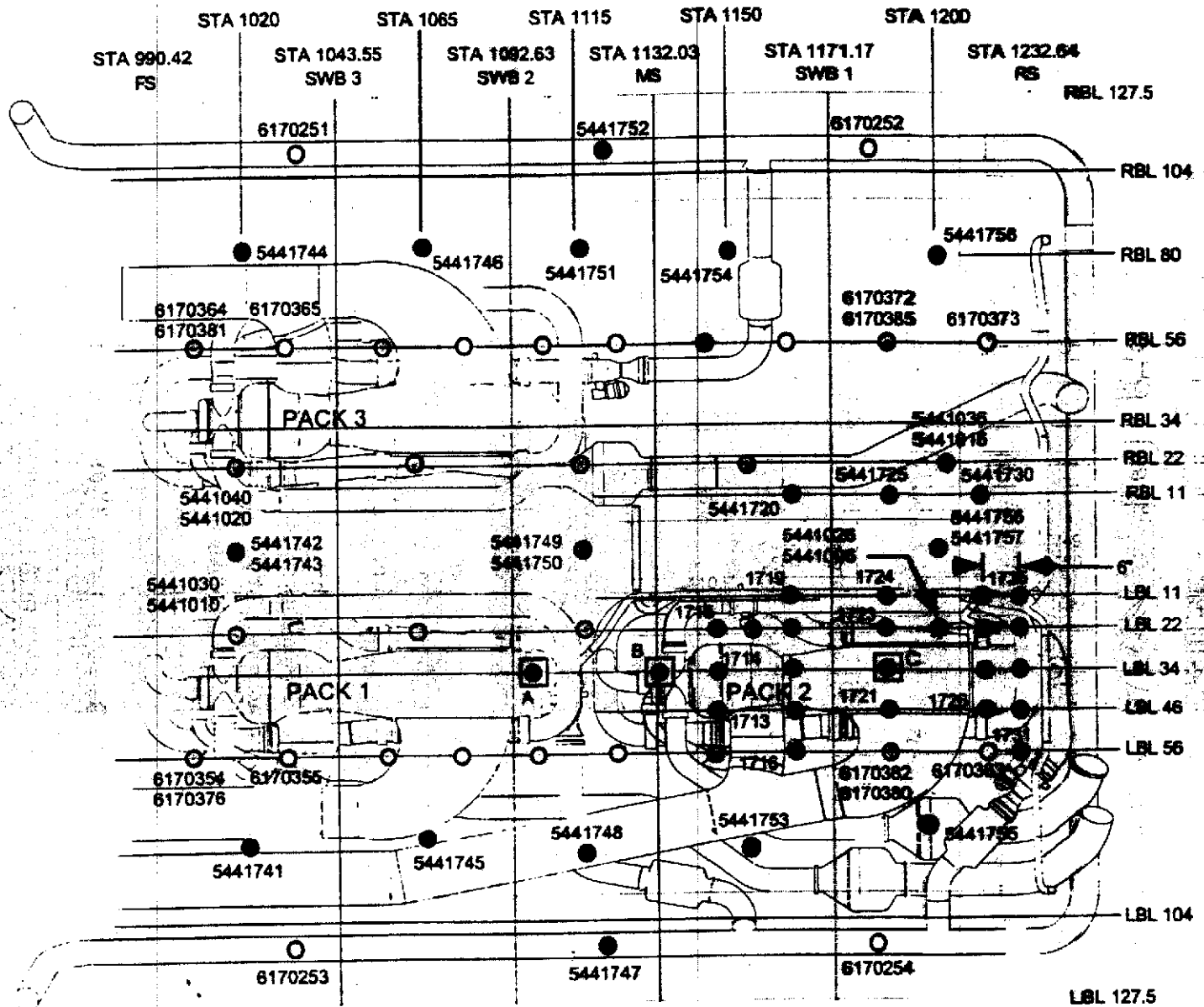

- NEW SURFACE TEMP (12 TOTAL)
 - NEW SURFACE & AMBIENT TEMP (6 TOTAL)
 - EXISTING SURFACE & AMBIENT TEMP W/ SENSOR NUMBER (40 TOTAL)
 - EXISTING SURFACE TEMP W/ SENSOR NUMBER (14 TOTAL)
 - NEW SURFACE TEMP (22 TOTAL, SUPPLIED BY NTSB)
 - NEW HEAT TRANSFER GAGE (3 TOTAL, SUPPLIED BY NTSB)
- A 5441781 (SENSOR), 5441781 (HEAT TRANSFER GAGE), 5441791 (RADIATION GAGE)
 B 5441783 (SENSOR), 5441783 (HEAT TRANSFER GAGE), 5441793 (RADIATION GAGE)
 C 5441782 (SENSOR), 5441782 (HEAT TRANSFER GAGE), 5441792 (RADIATION GAGE)

Boeing Proprietary

Figure 2.4 CWT internal instrumentation locations.

747-100 PACK BAY INSTRUMENTATION (ECS ONLY)

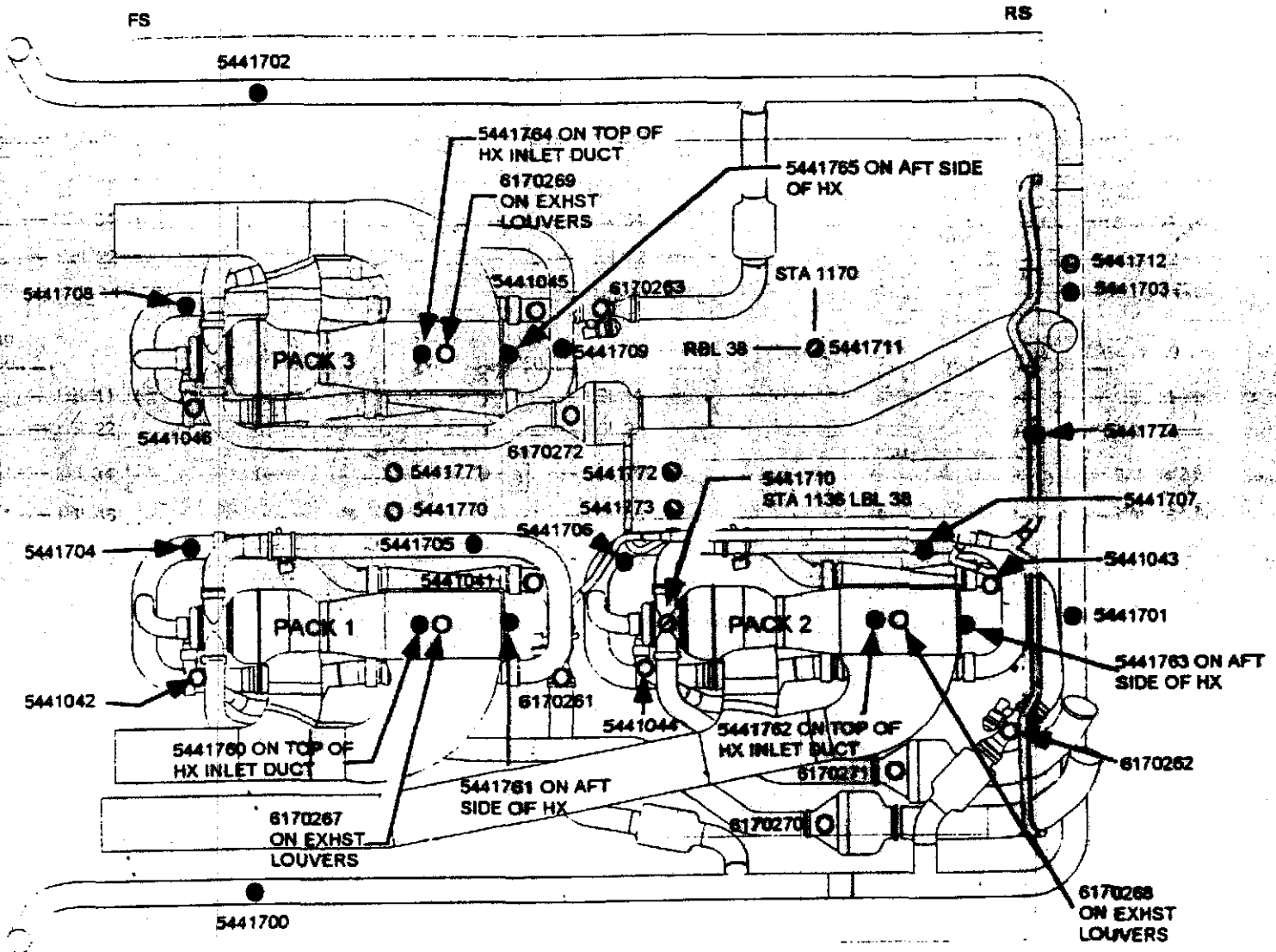

- NEW DUCT/HARDWARE SURFACE TEMP (14 TOTAL)
- ⊕ NEW INSULATION SURFACE TEMP (1 TOTAL)
- ⊙ NEW DOOR PANEL INSIDE SURFACE TEMP (2 TOTAL)
- ⊙ NEW KEEL BEAM INSIDE SURFACE TEMP (4 TOTAL)
- EXISTING SURFACE TEMP W/ SENSOR NUMBER (12 TOTAL)

Figure 2.5 ECS pack instrumentation.

Test 1
Bay 1

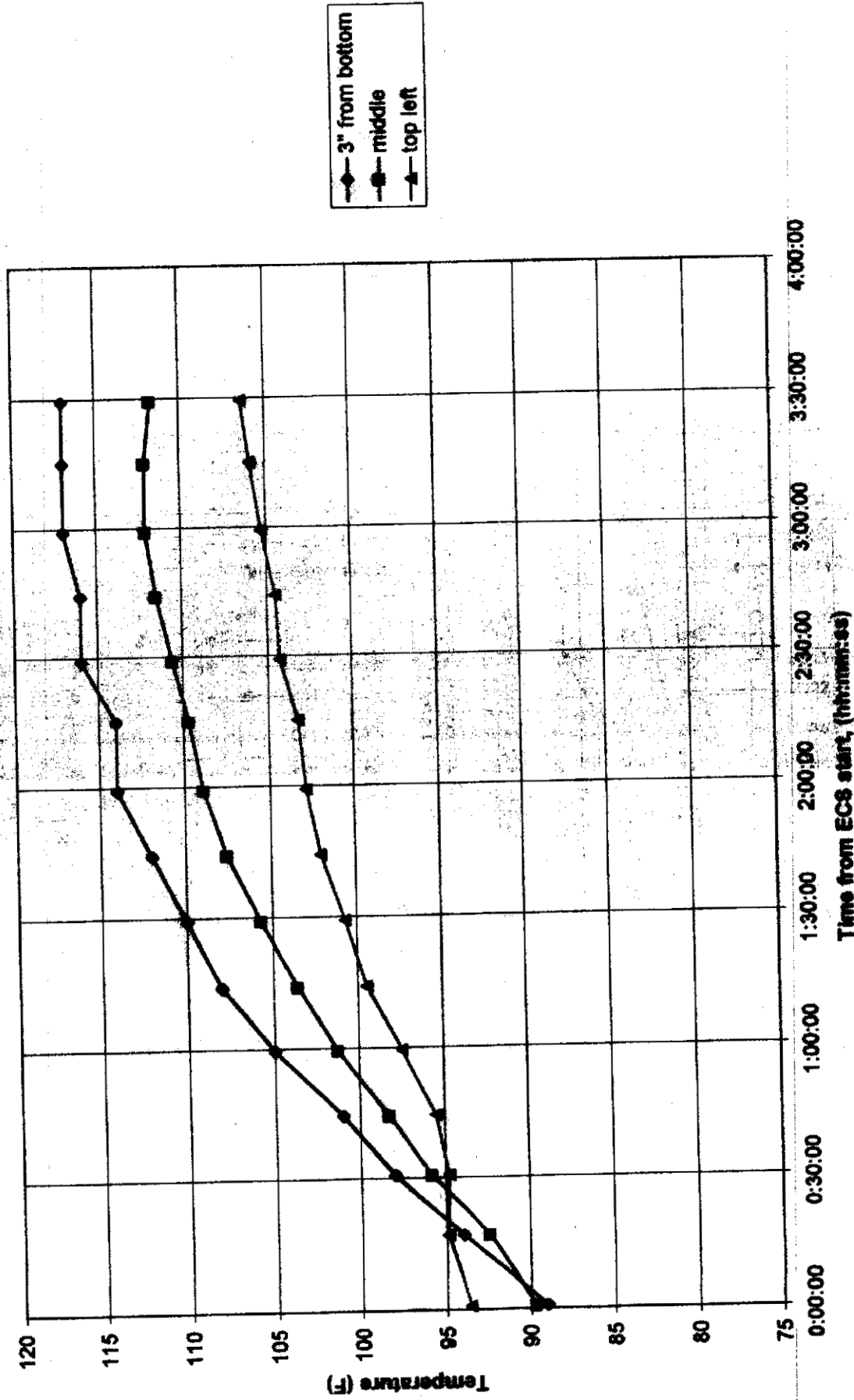

Figure 3.1a Bay 1 outage temperatures, Test 1.

Test 1
Bay 2

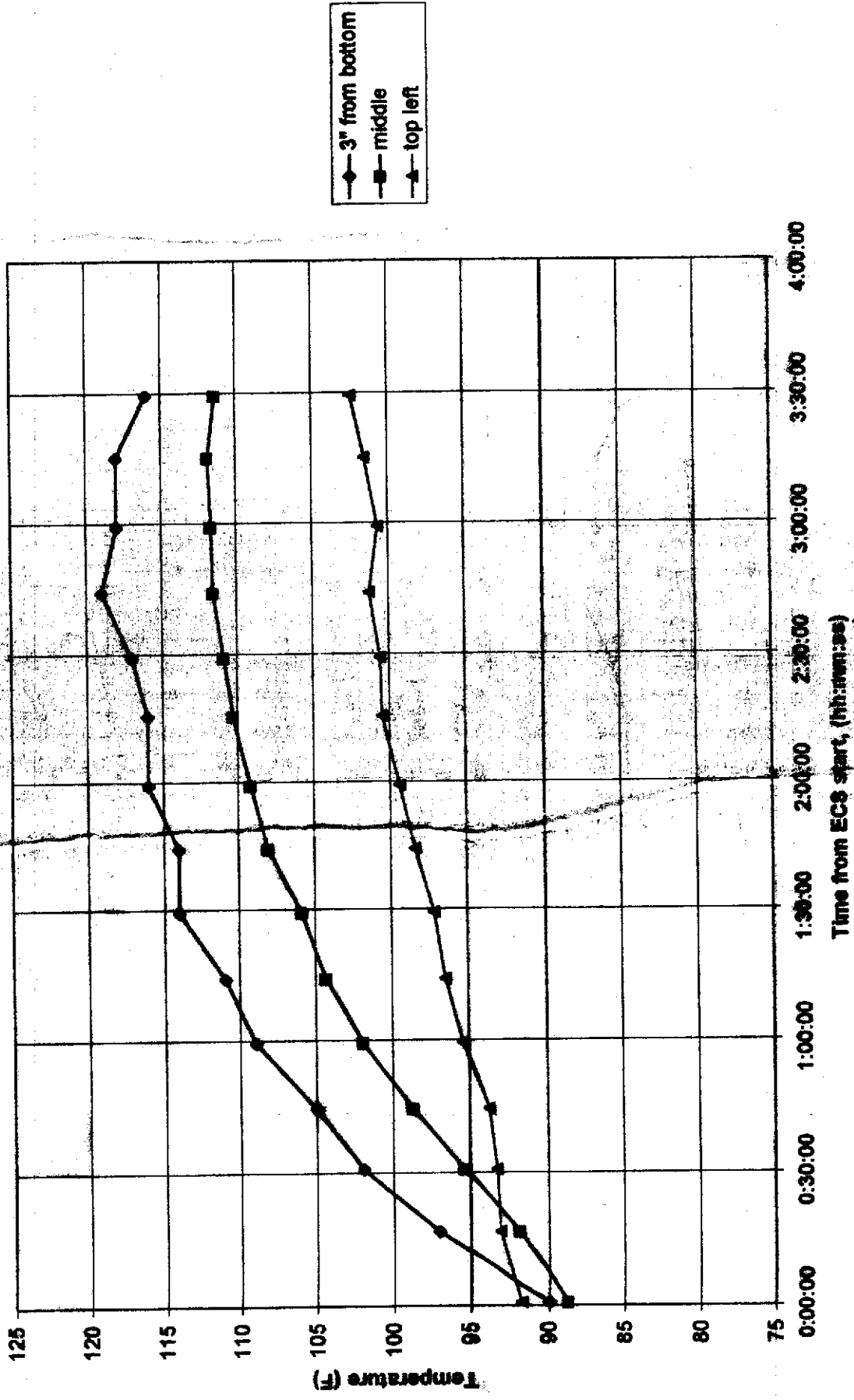

Figure 3.1b Bay 2 off-gas temperatures, Test 1

Test 1
Left Mid Bay

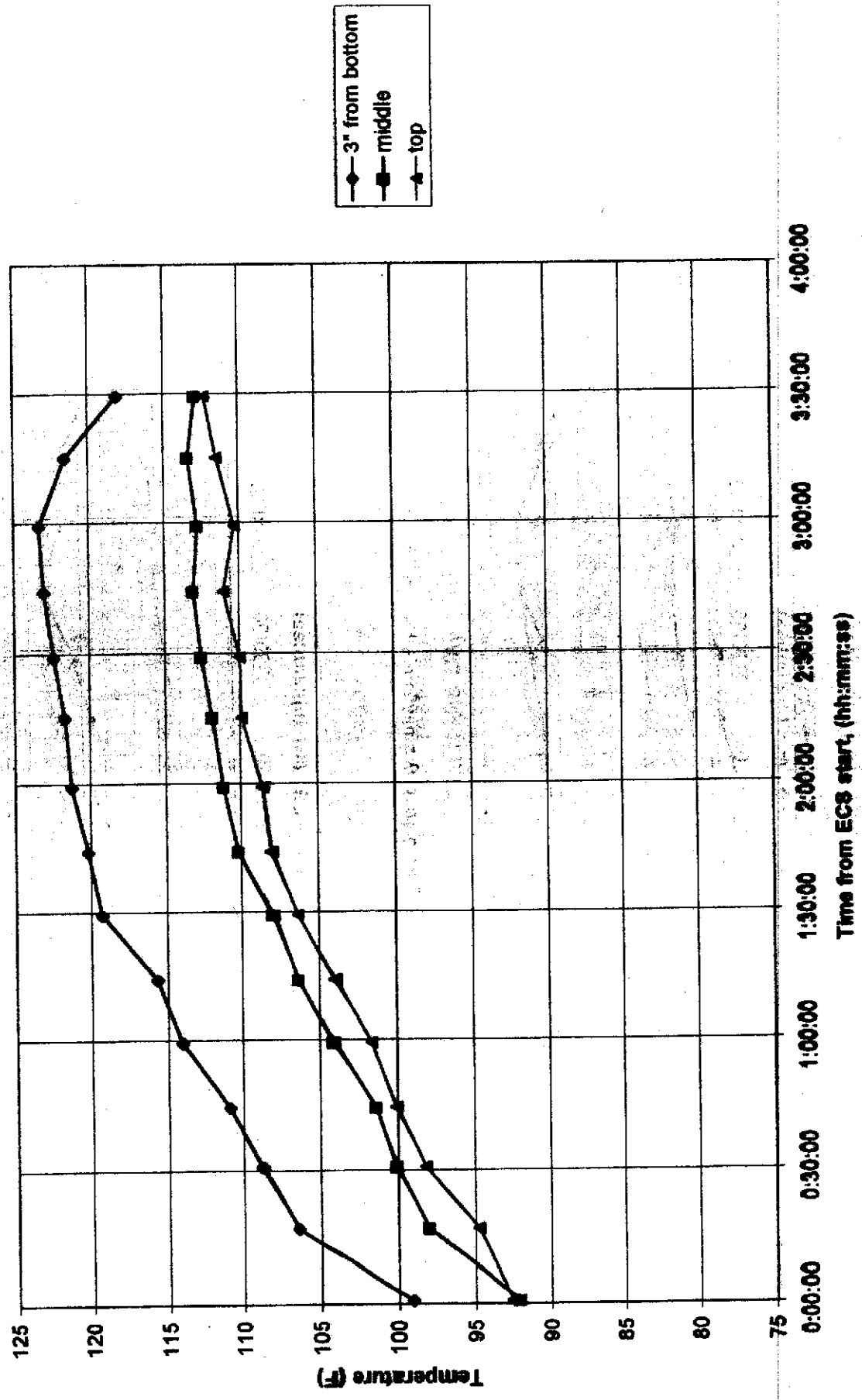

Figure 3.1c Left Mid Bay ullage temperatures, Test1.

Figure 3.1d Right Mid-Bay village temperatures, Test 1.

Test 1 Right Mid Bay

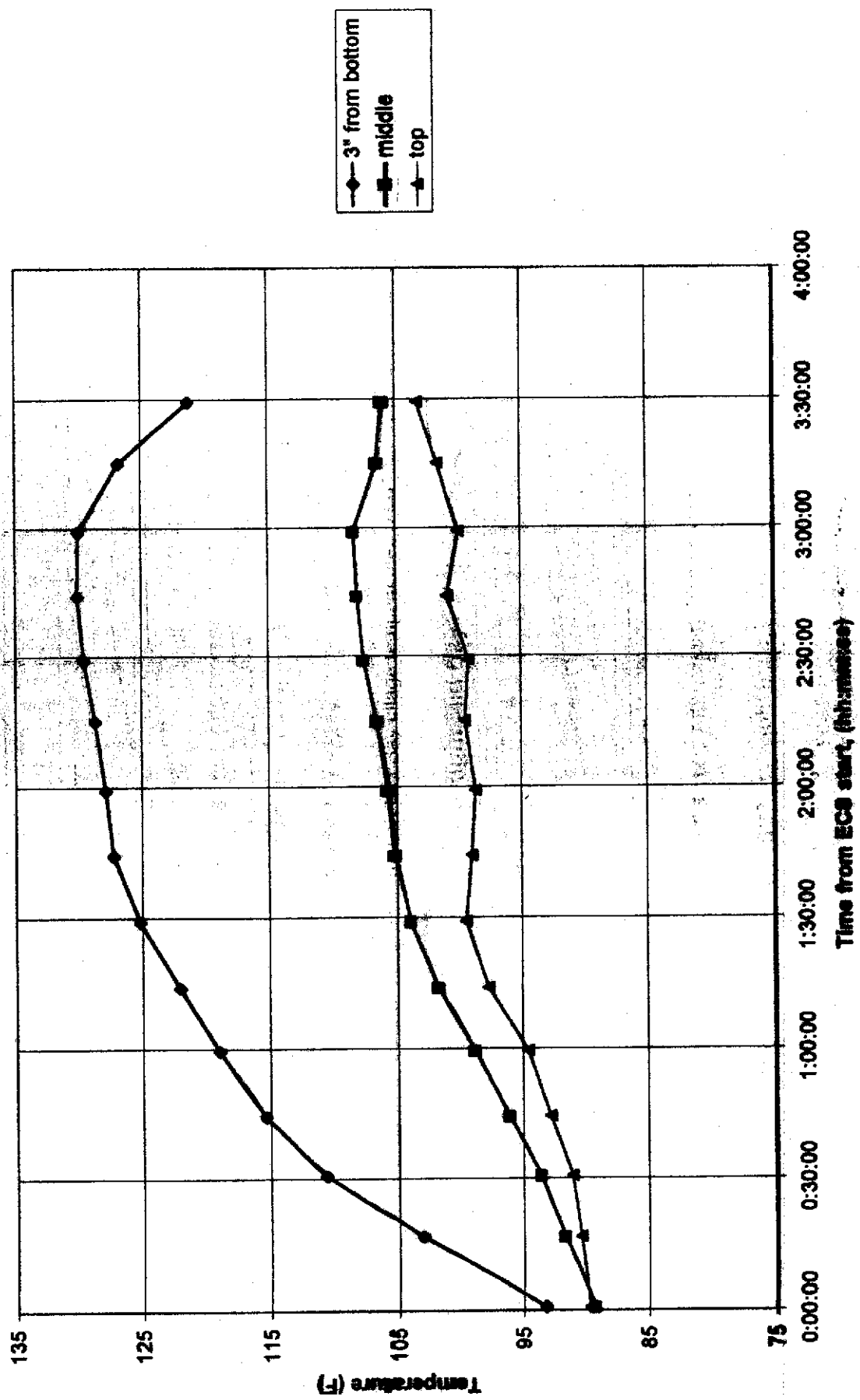

Figure 3.1d Right Mid-Bay village temperatures, Test 1.

Test 1
Left Aft Bay

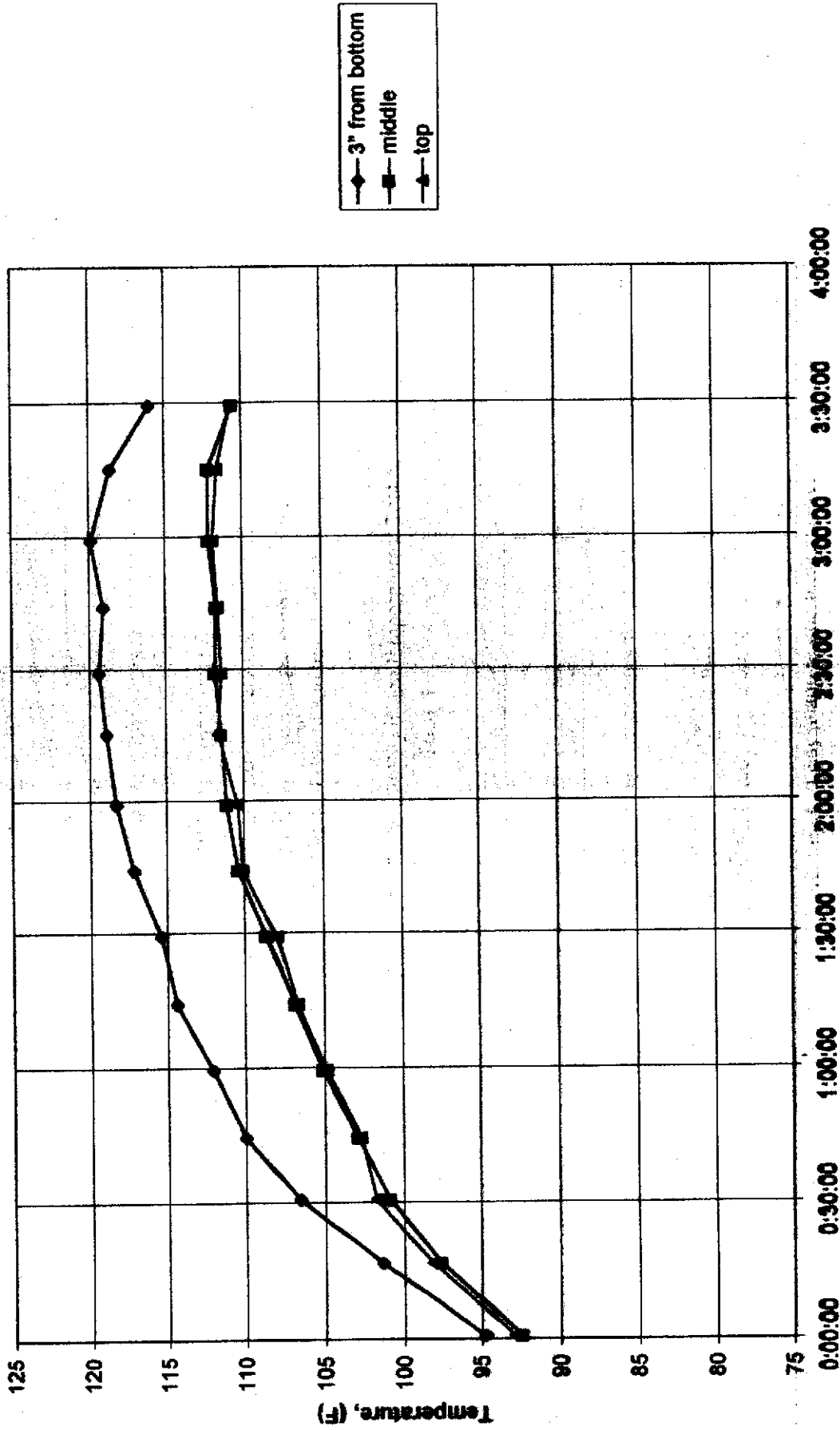

Figure 3.1e Left Aft Bay ullage temperatures, Test 1.

Test 1
Right Aft Bay

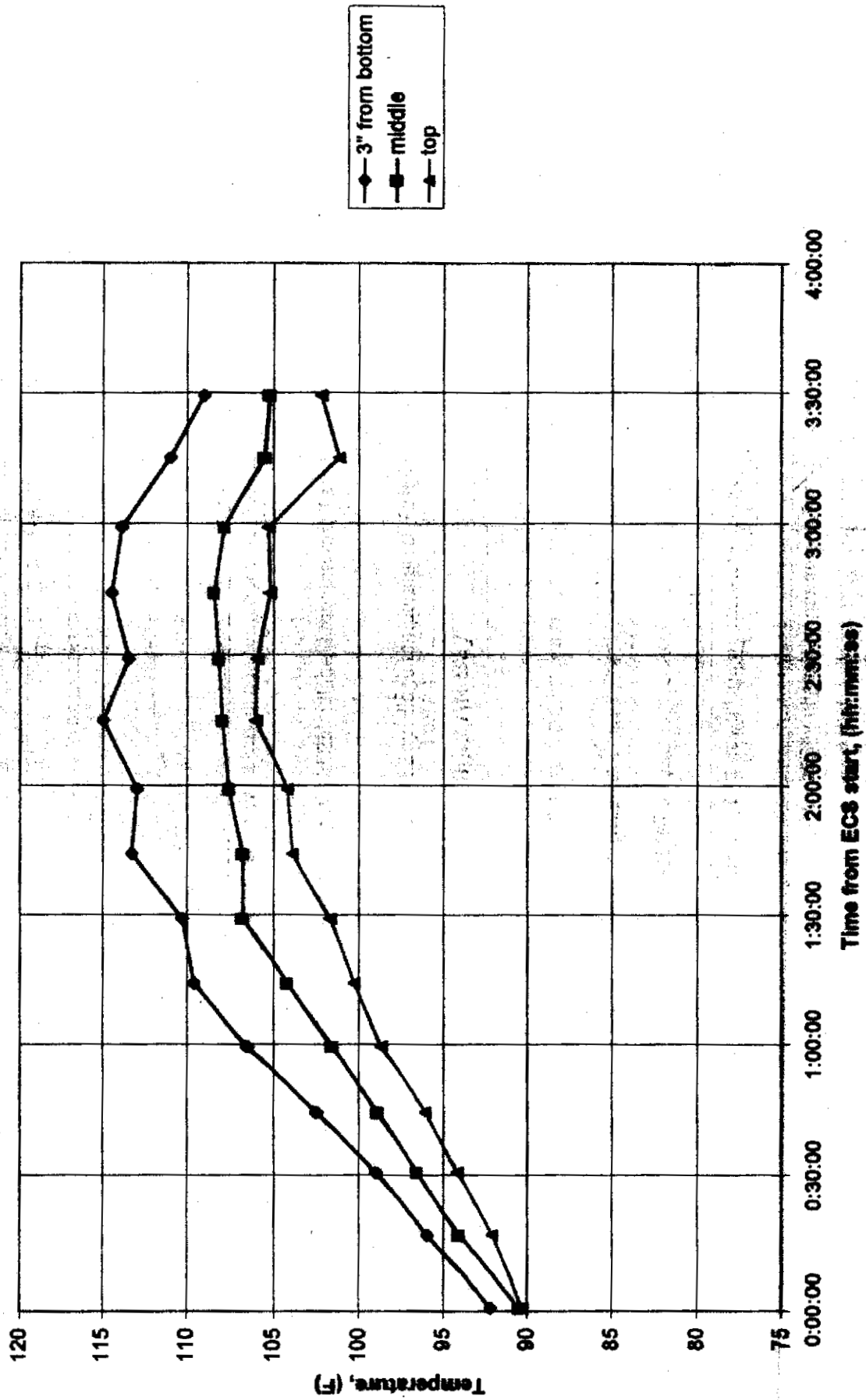

Figure 3.1f Right Aft Bay ullage temperatures, Test 1.

Temperature (F) vs. Time (hh:mm:ss) for Bay 1 ullage temperatures, Test 2

Test 2 Bay 1

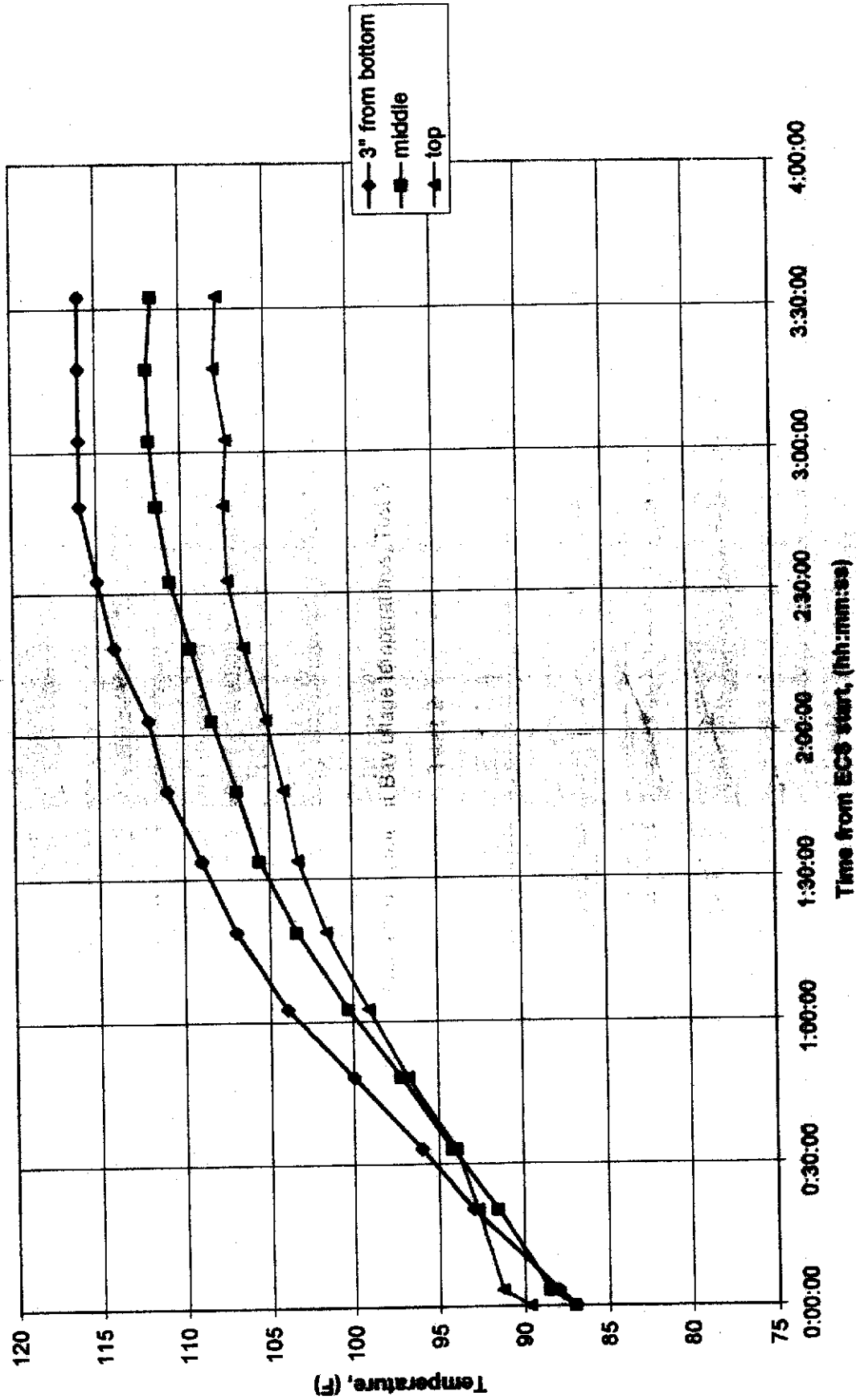

Figure 3.2a Bay 1 ullage temperatures, Test 2.

Test 2
Bay 2

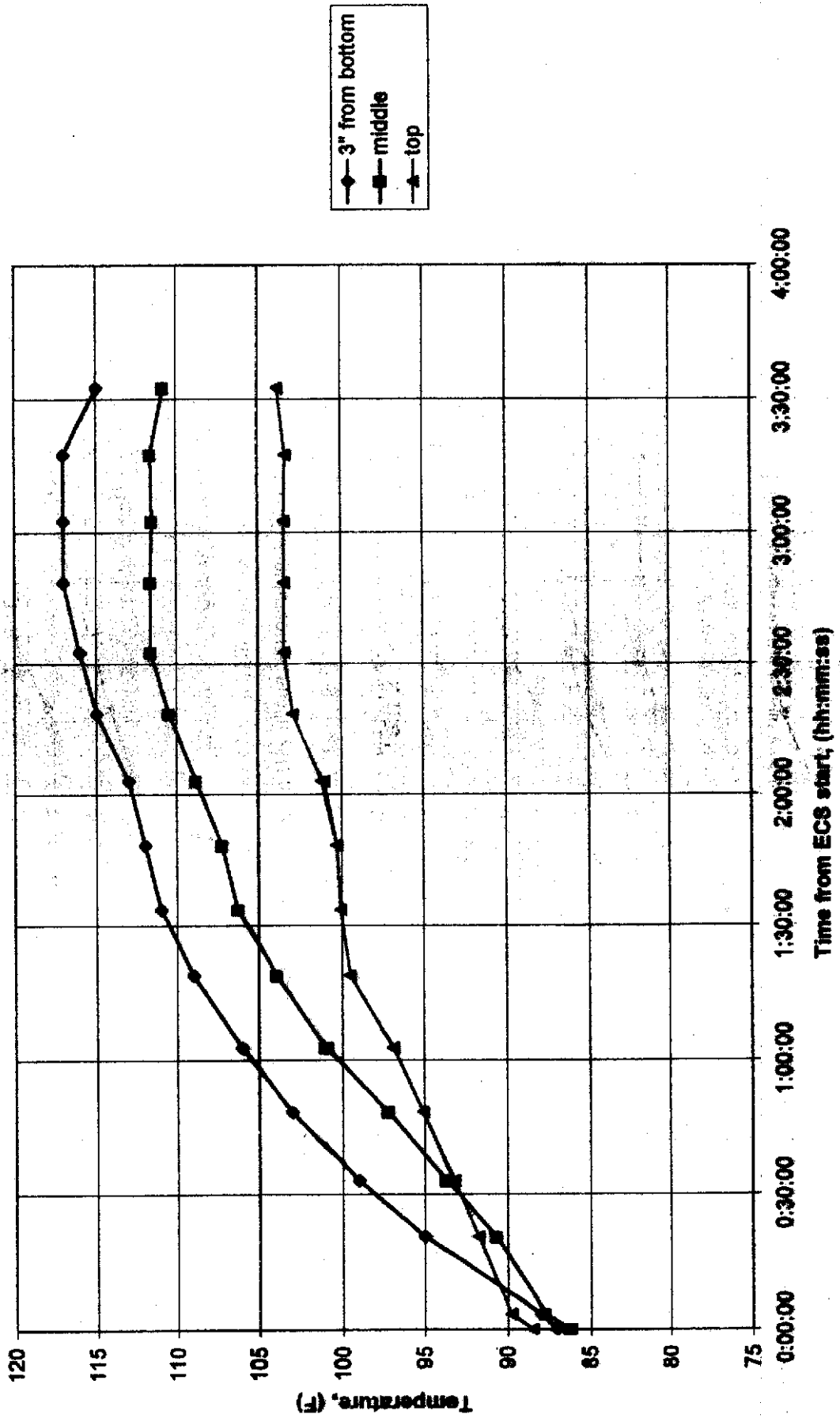

Figure 3.2b Bay 2 ullage temperatures, Test 2.

Test 2
Left Mid Bay

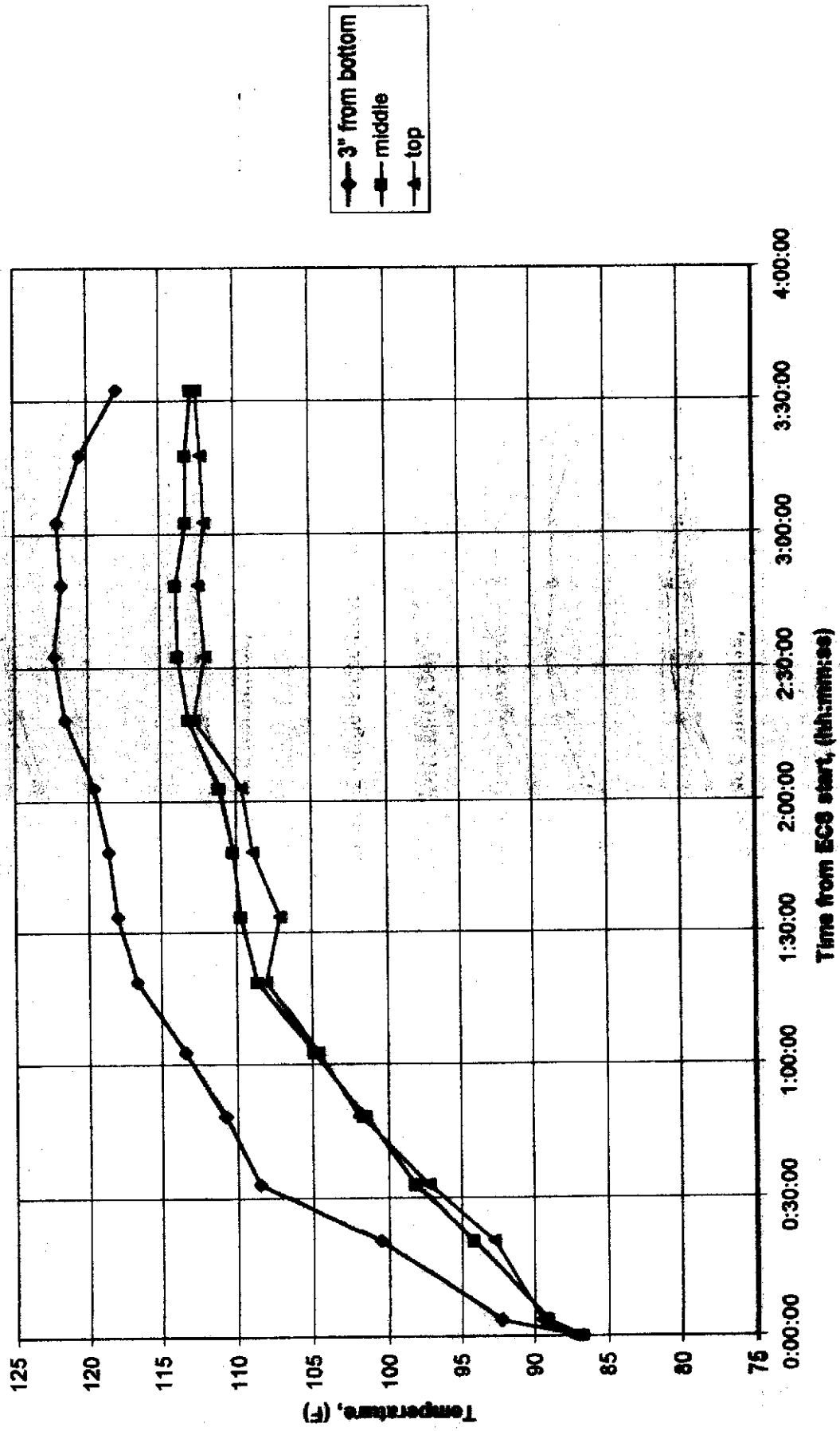

Figure 3.2c Left Mid Bay ullage temperatures, Test 2.

Right Mid Bay
 Test 2

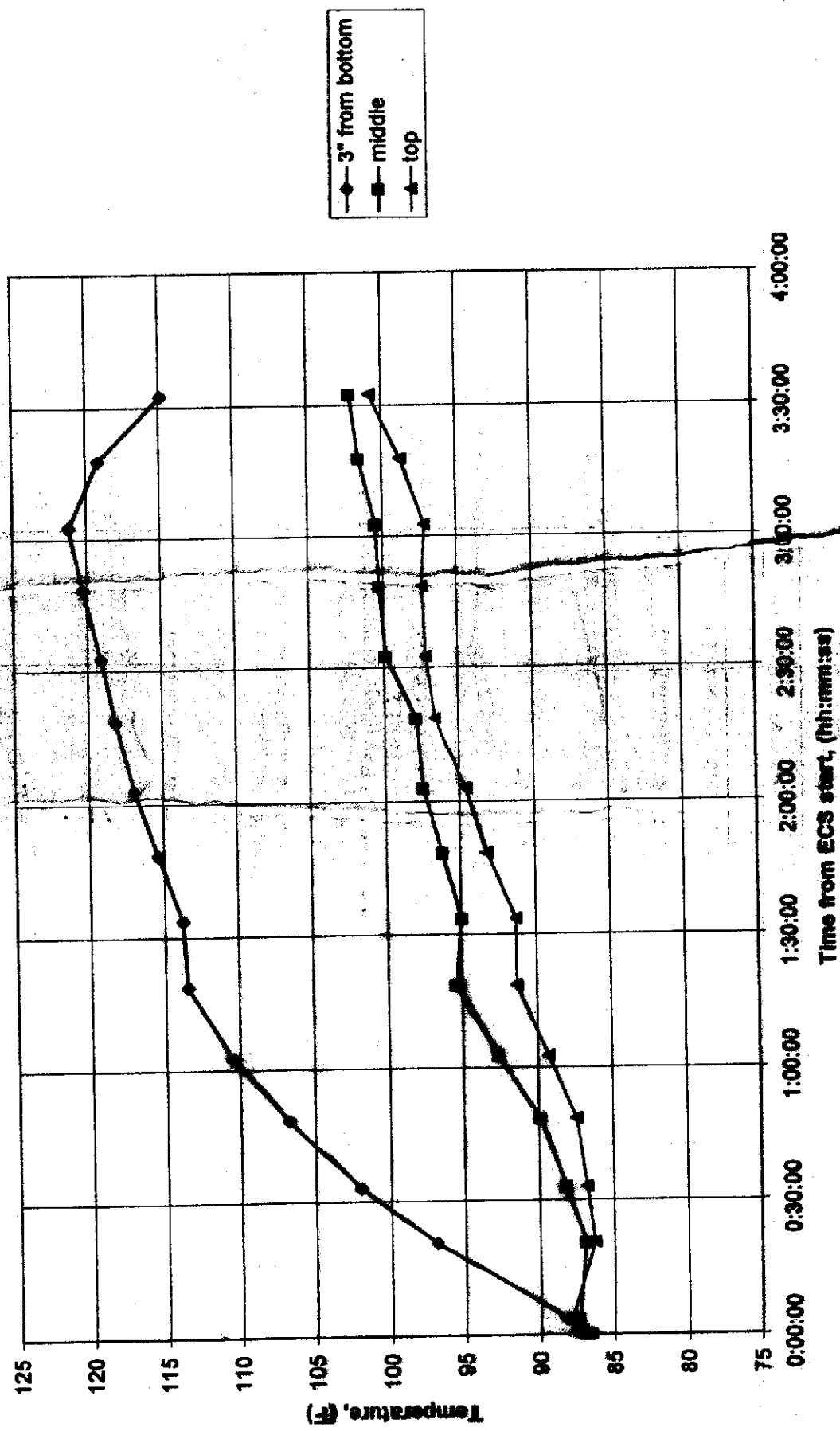

Figure 3.2d Right Mid Bay Inage Temperatures, Test 2.

Test Z
Left Aft Bay

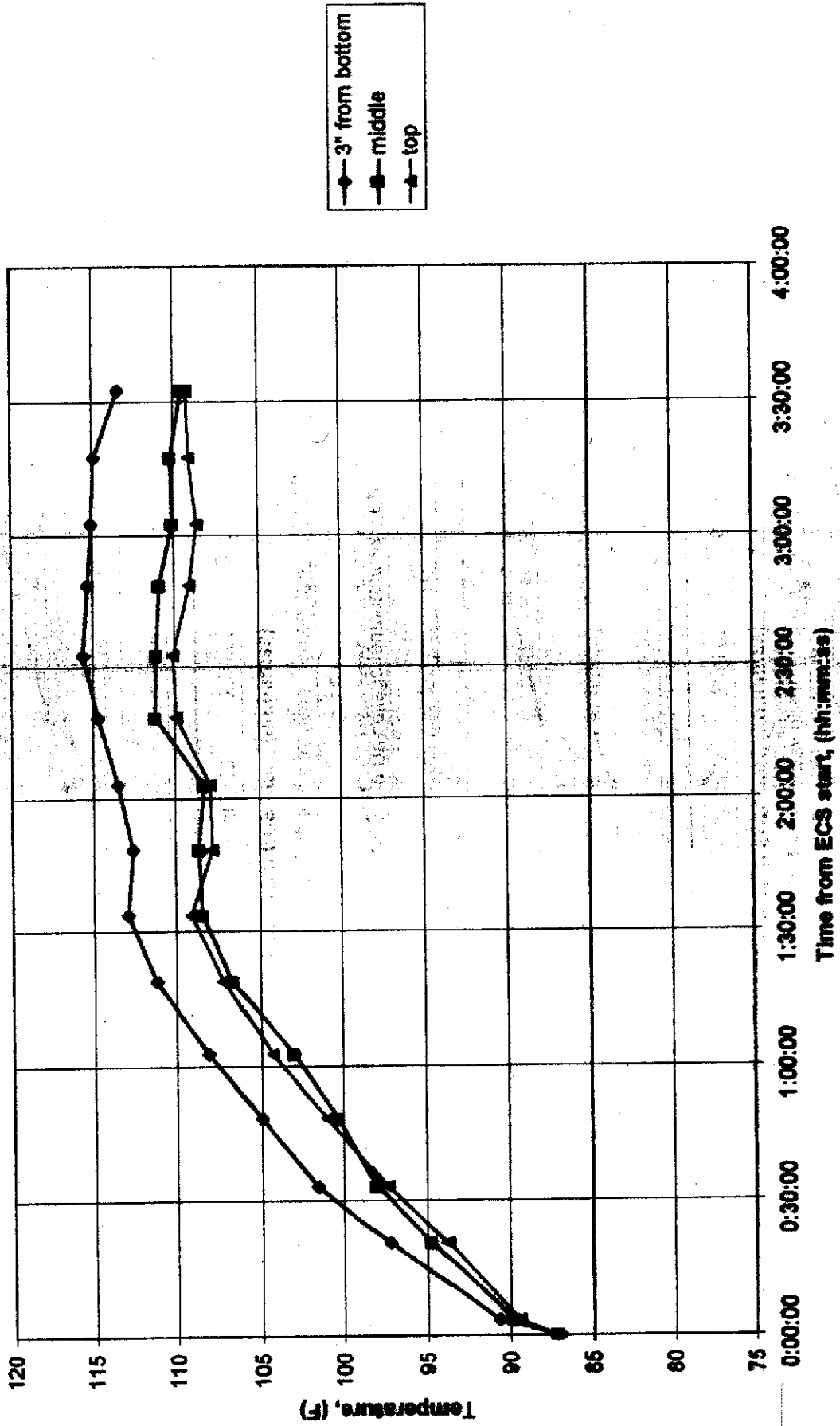

Figure 3.2e Left Aft Bay ullage temperatures, Test 2.

Right Aft Bay
 Test 2

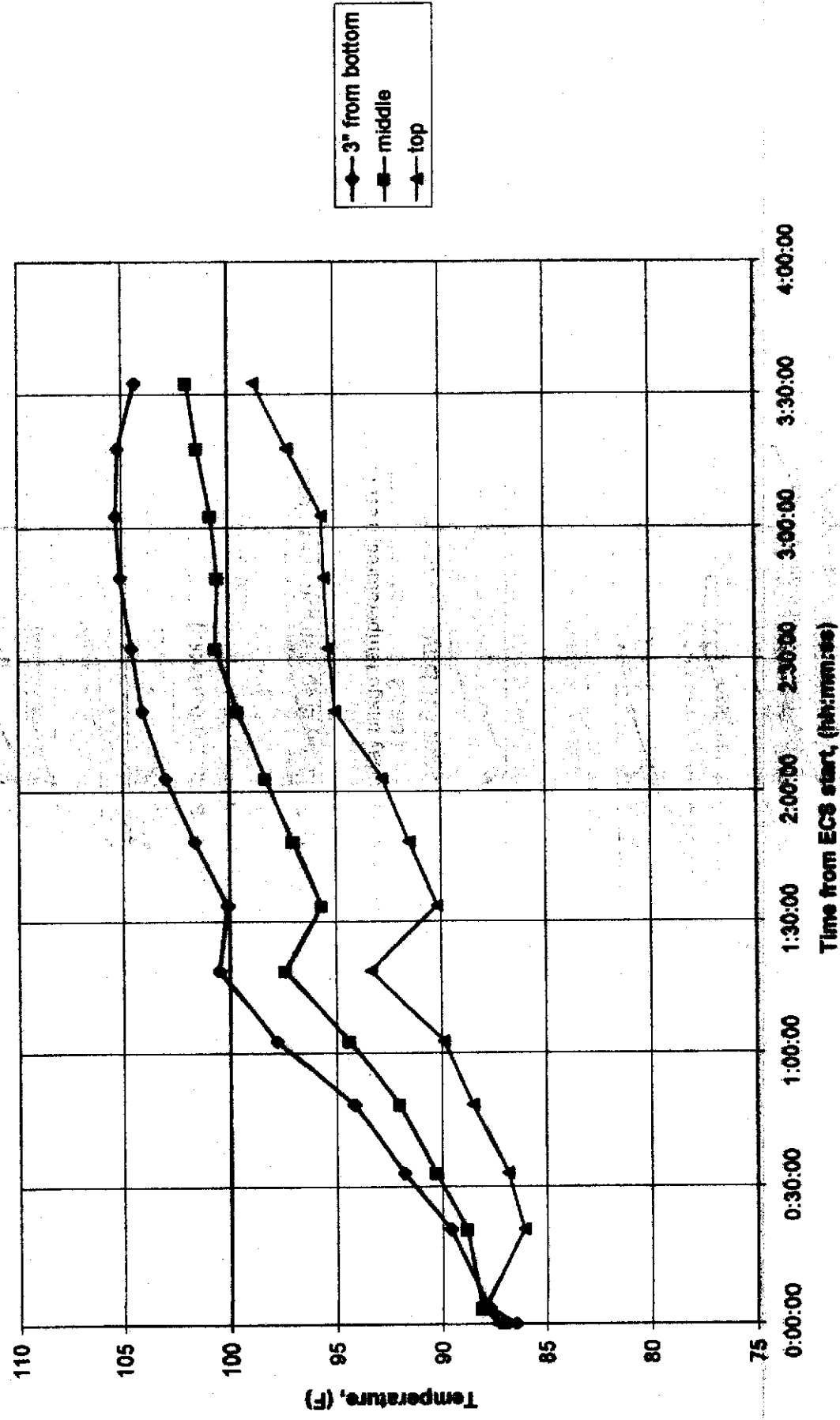

Figure 3.2f Right Aft Bay ullage temperatures, Test 2.

Test 3
Bay 1

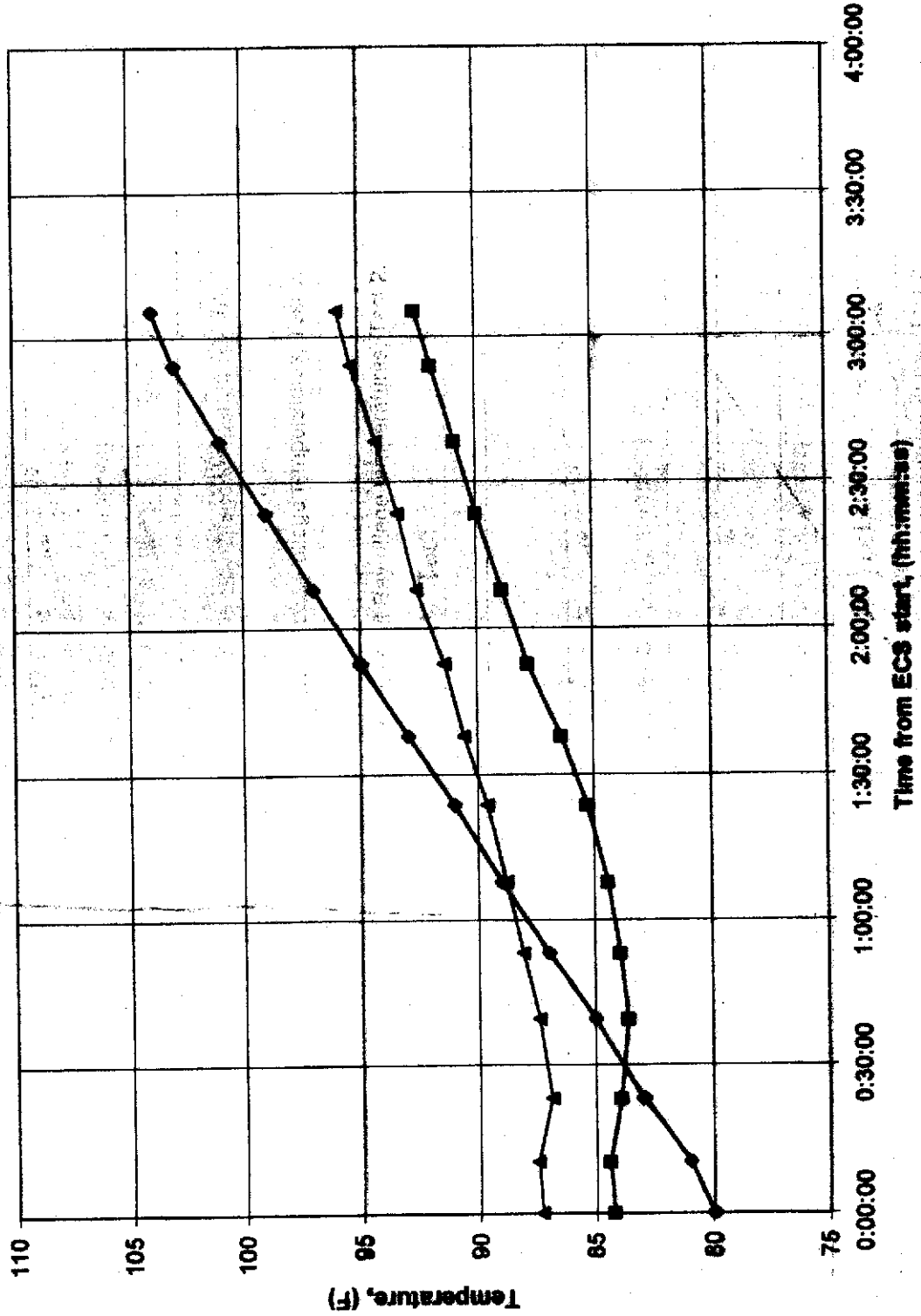

Figure 3.3a Bay 1 ullage temperatures, Test 3.

Test 3
Bay 2

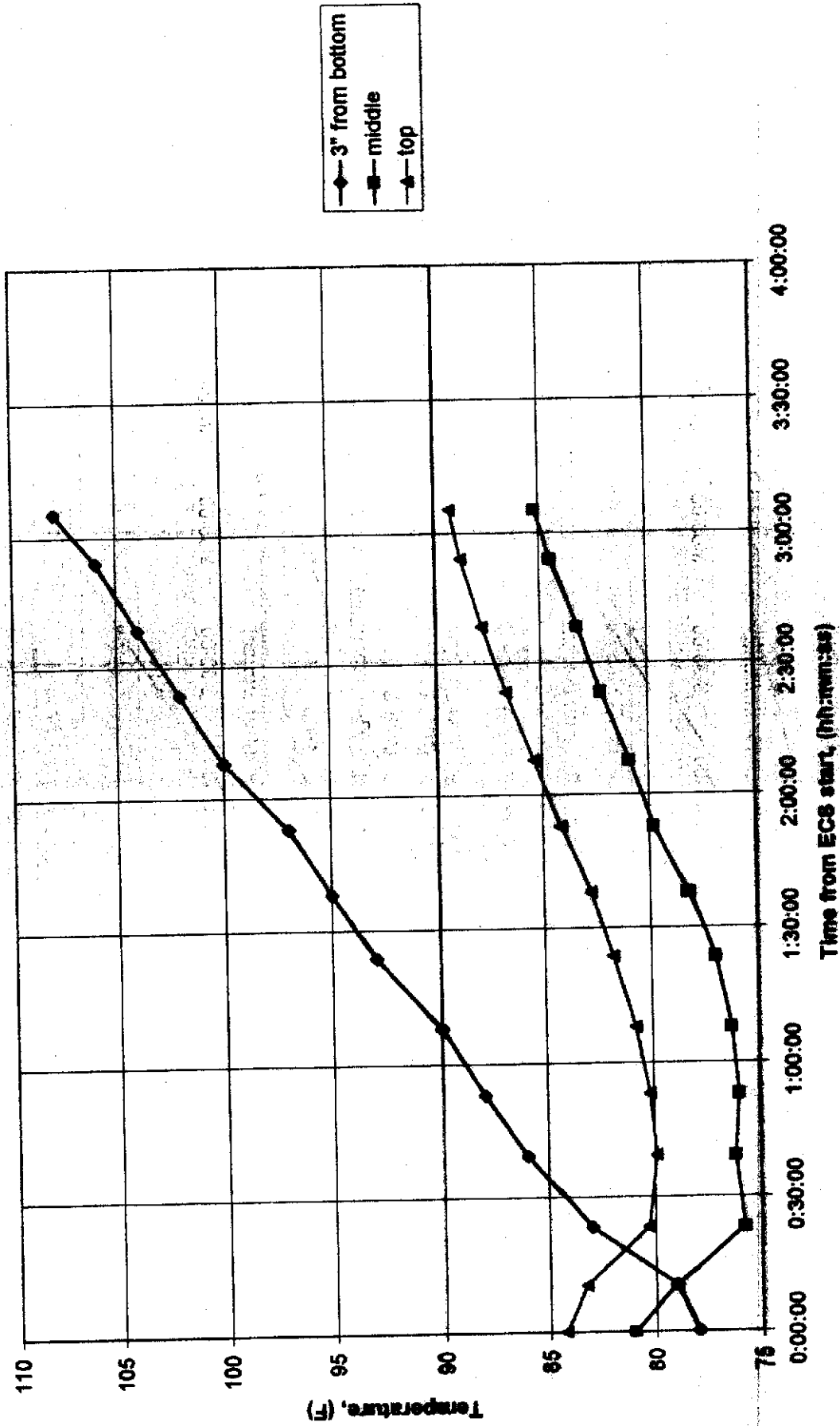

Figure 3.3b Bay 2 ullage temperatures, Test 3.

Figure 3.3c Left Mid Bay ullage temperatures, Test 3

Test 3 Left Mid Bay

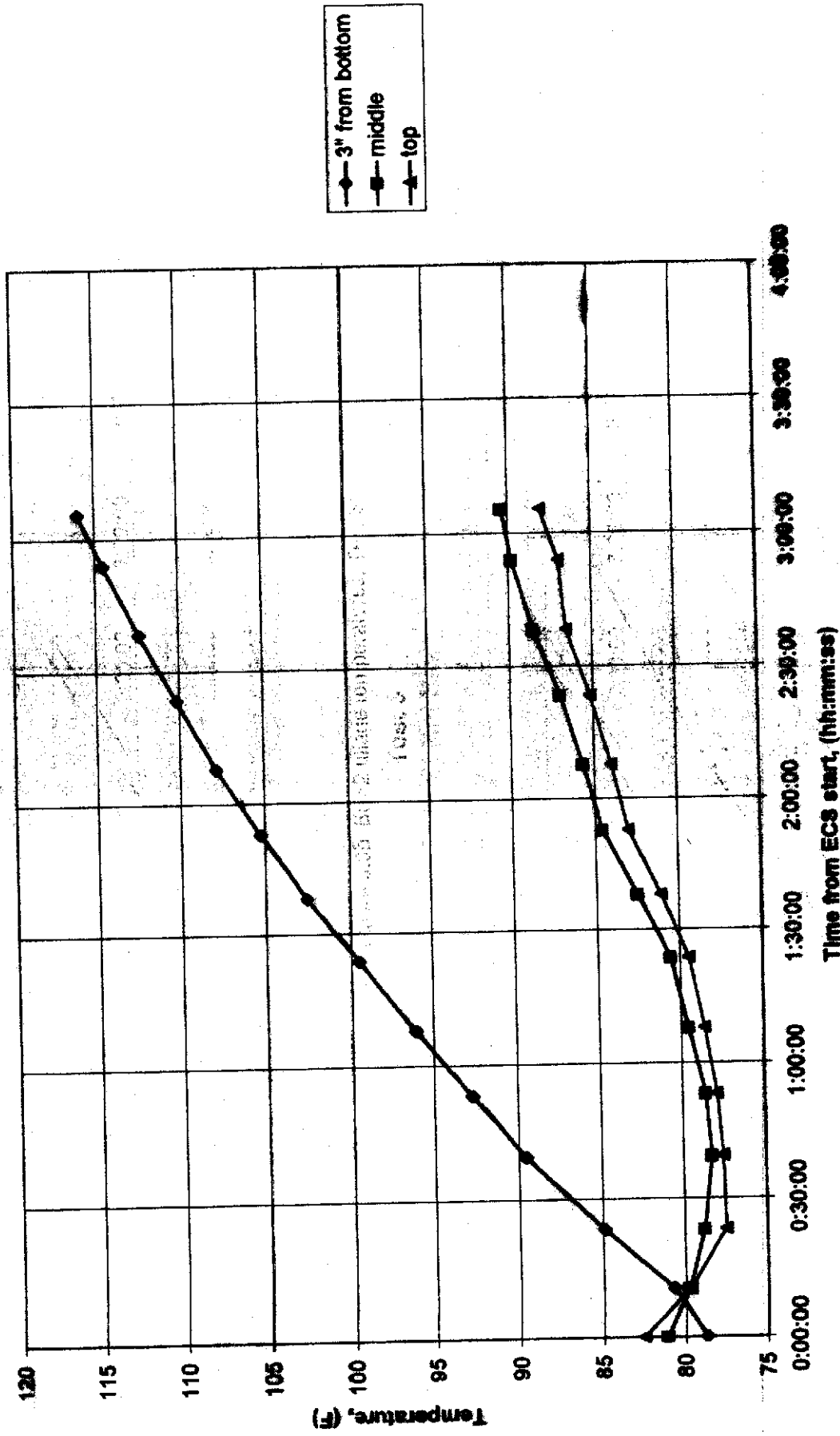
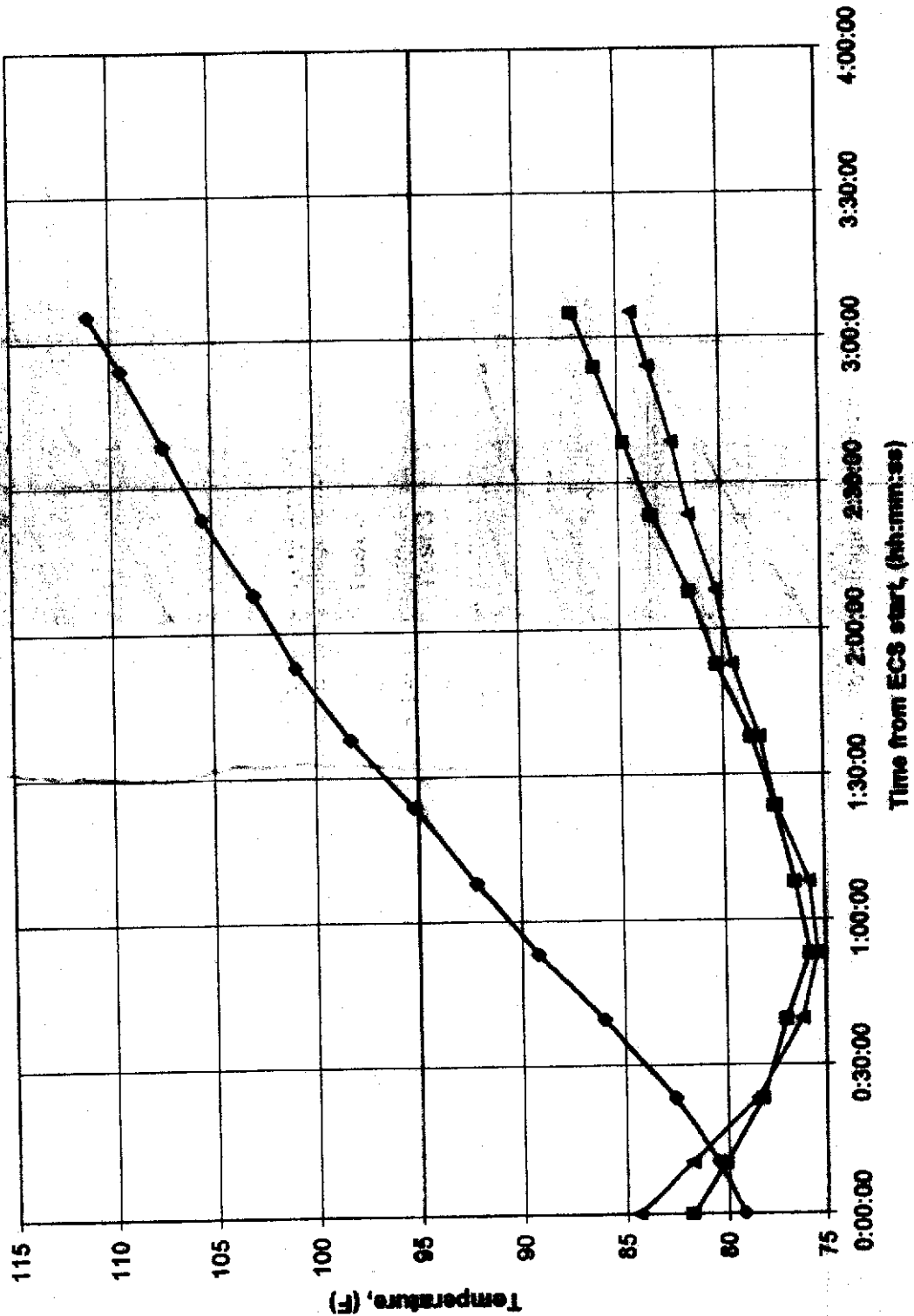

Figure 3.3c Left Mid Bay ullage temperatures, Test 3.

Test 3
Right Mid Bay



● 3" from bottom
 ■ middle
 ▲ top

Figure 3.3d Right Mid Bay ullage temperatures, Test 3.

Test 3
Left Aft Bay

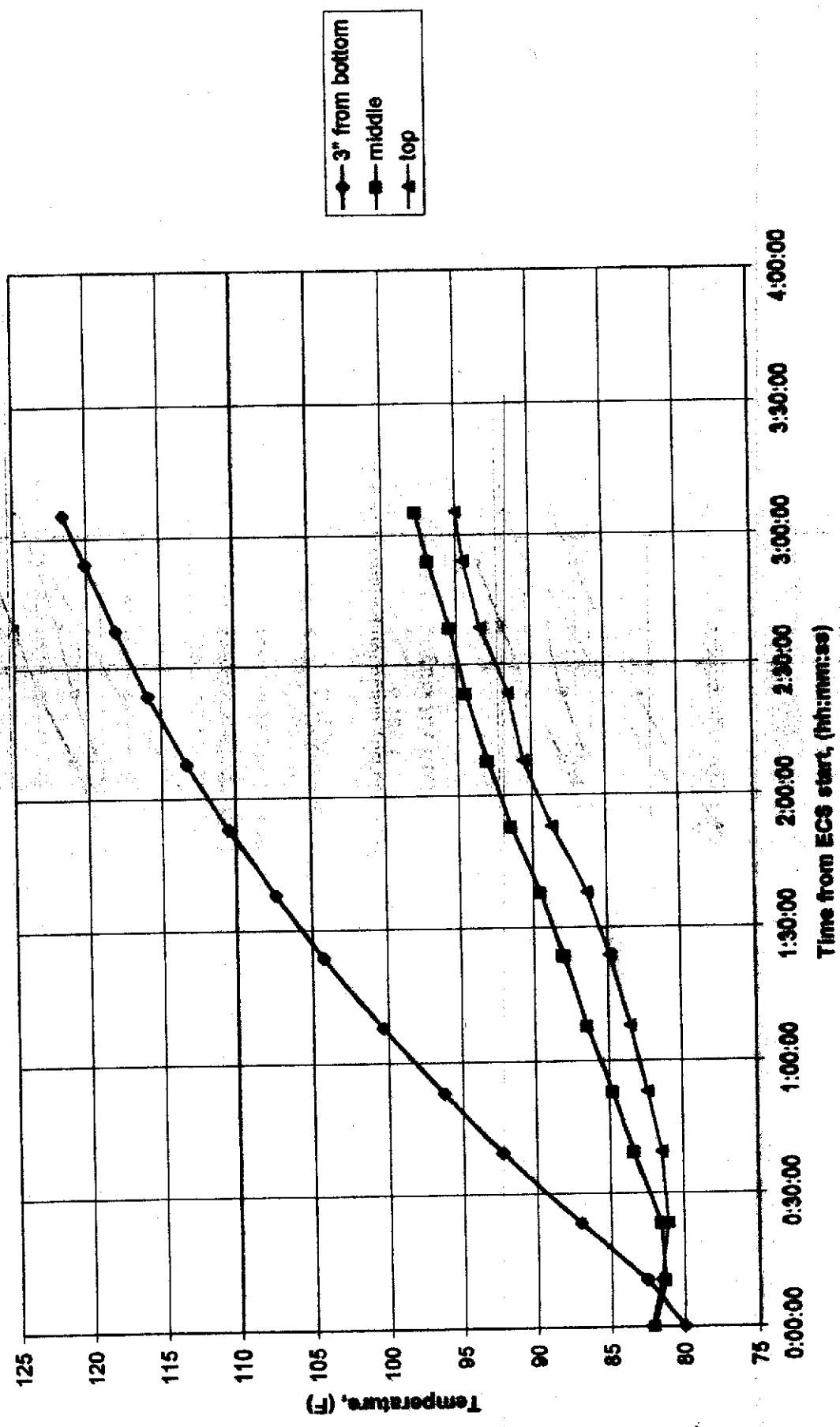

Figure 3.3e Left Aft Bay ullage temperatures, Test 3.

Right Aft Bay
 Test 3

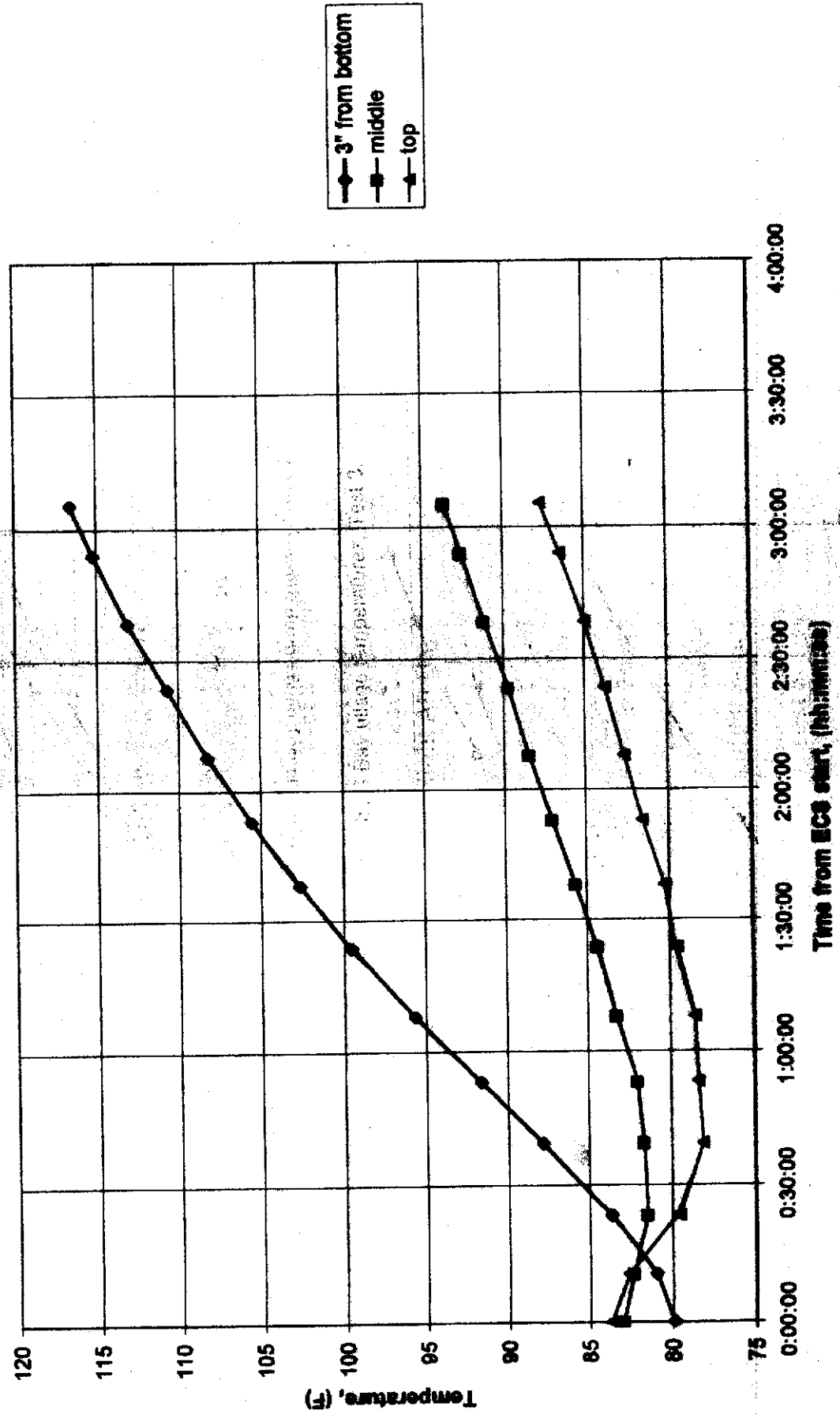

Figure 3.3f Right Aft Bay ullage temperatures Test 3.

Test 3
Fuel Temperatures 3-Inches From Bottom

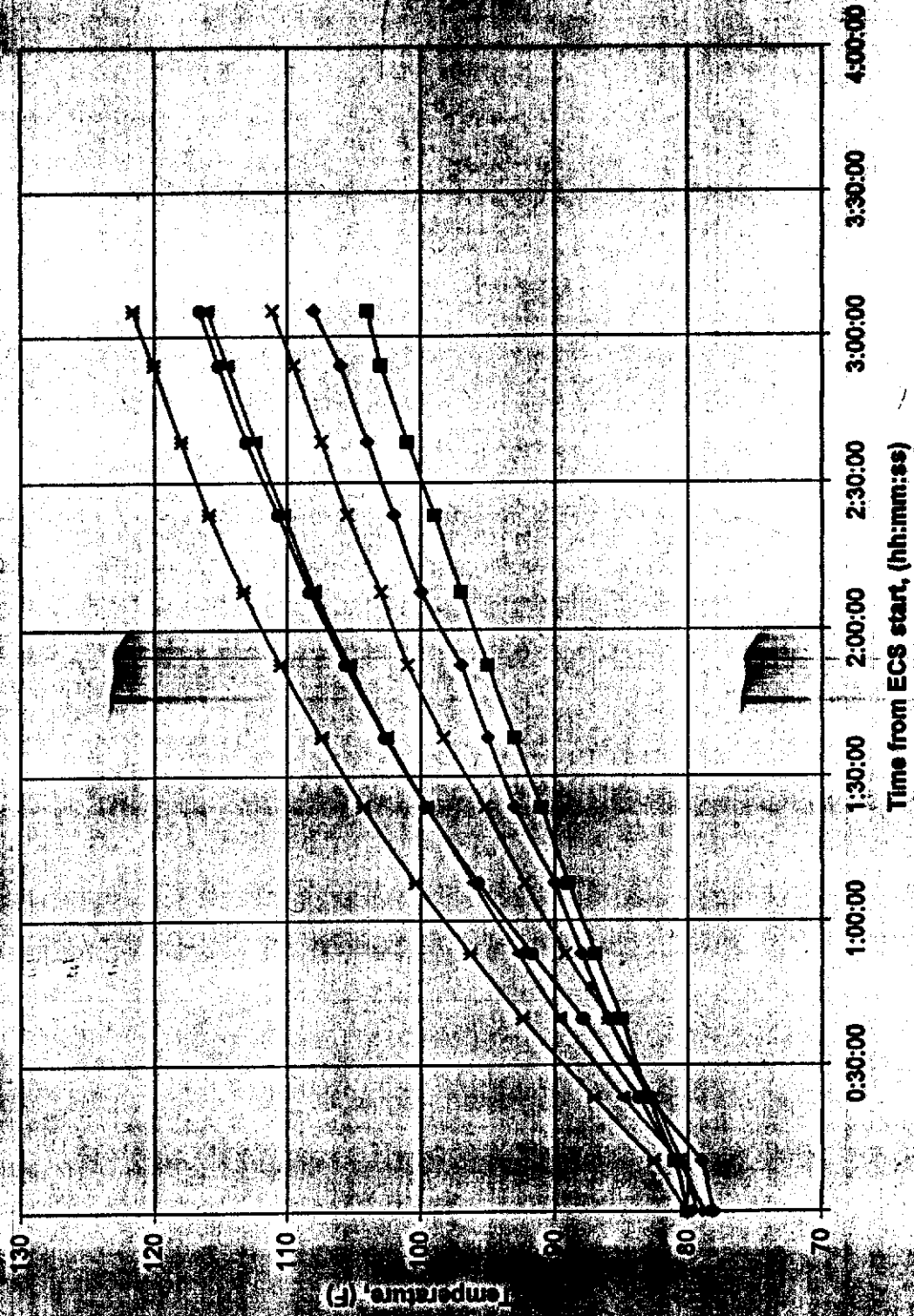

Figure 3.4 Fuel temperatures at 3-inch height, Test 3.

Test 1
CWT Internal Bottom Surface Temperatures

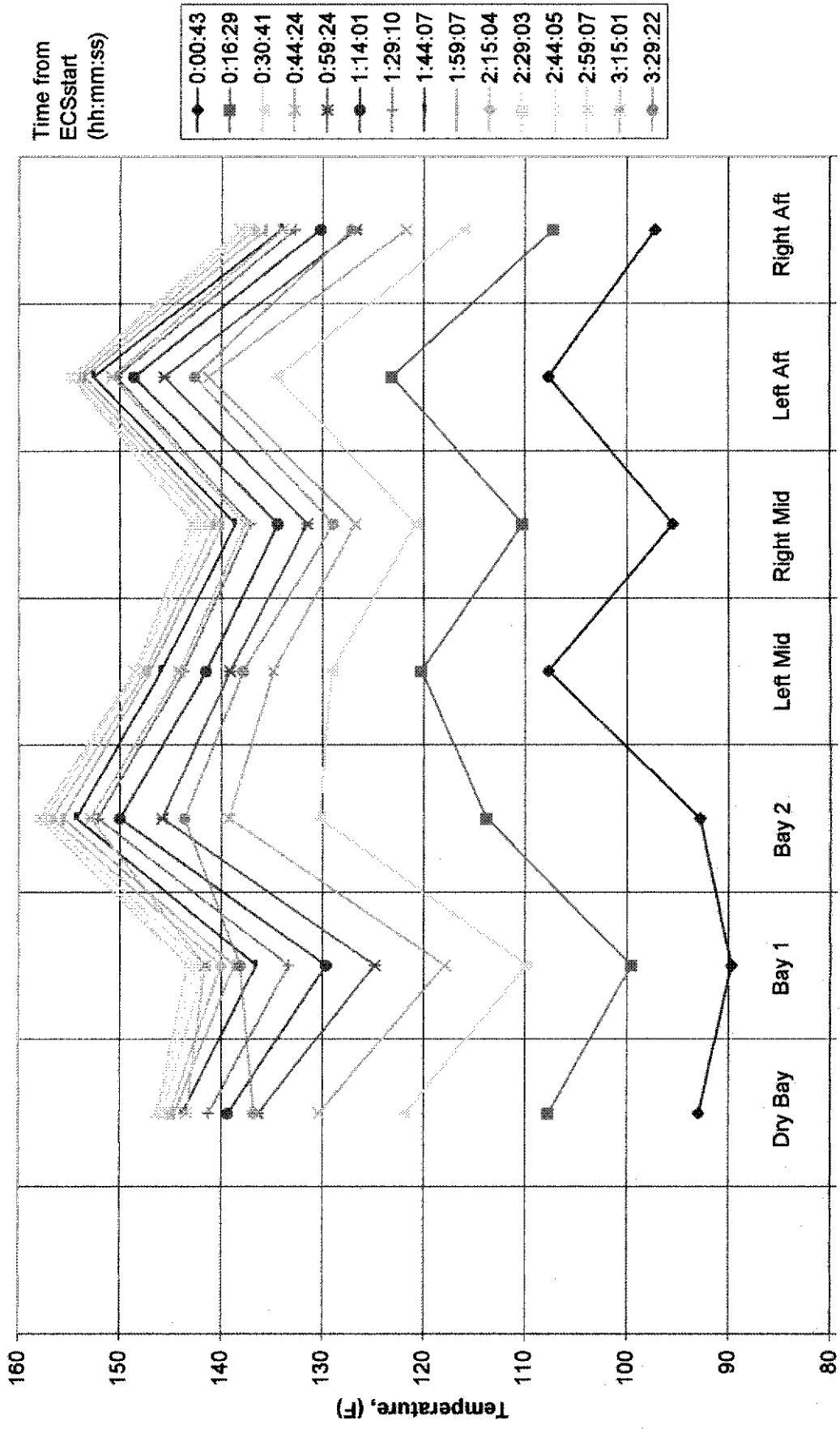

Figure 3.5 CWT bottom internal surface temperatures, Test 1.

Test 2

CWT Internal Bottom Surface Temperatures

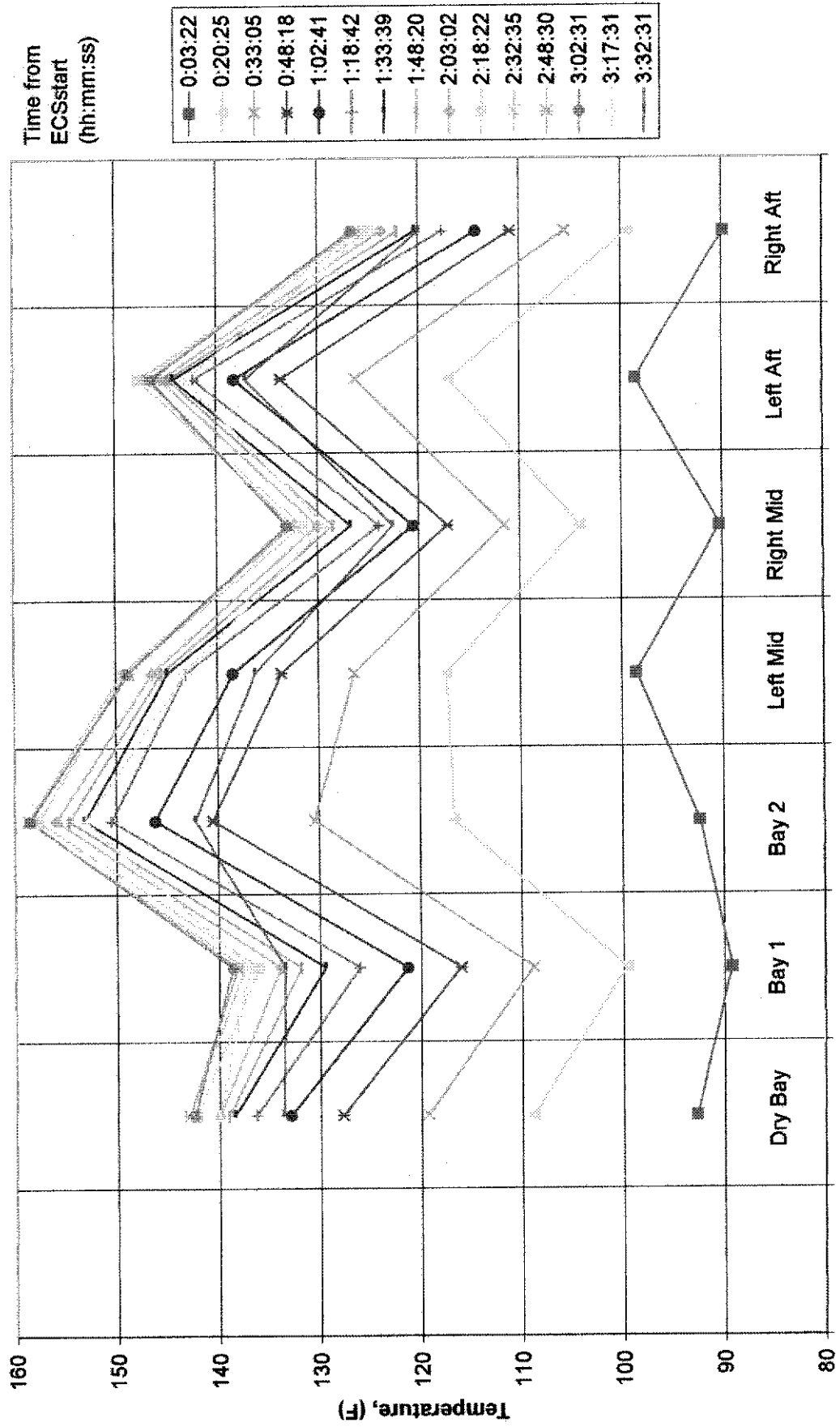

Figure 3.6 CWT bottom internal surface temperatures, Test 2.

Test 3
CWT Internal Bottom Surface Temperatures

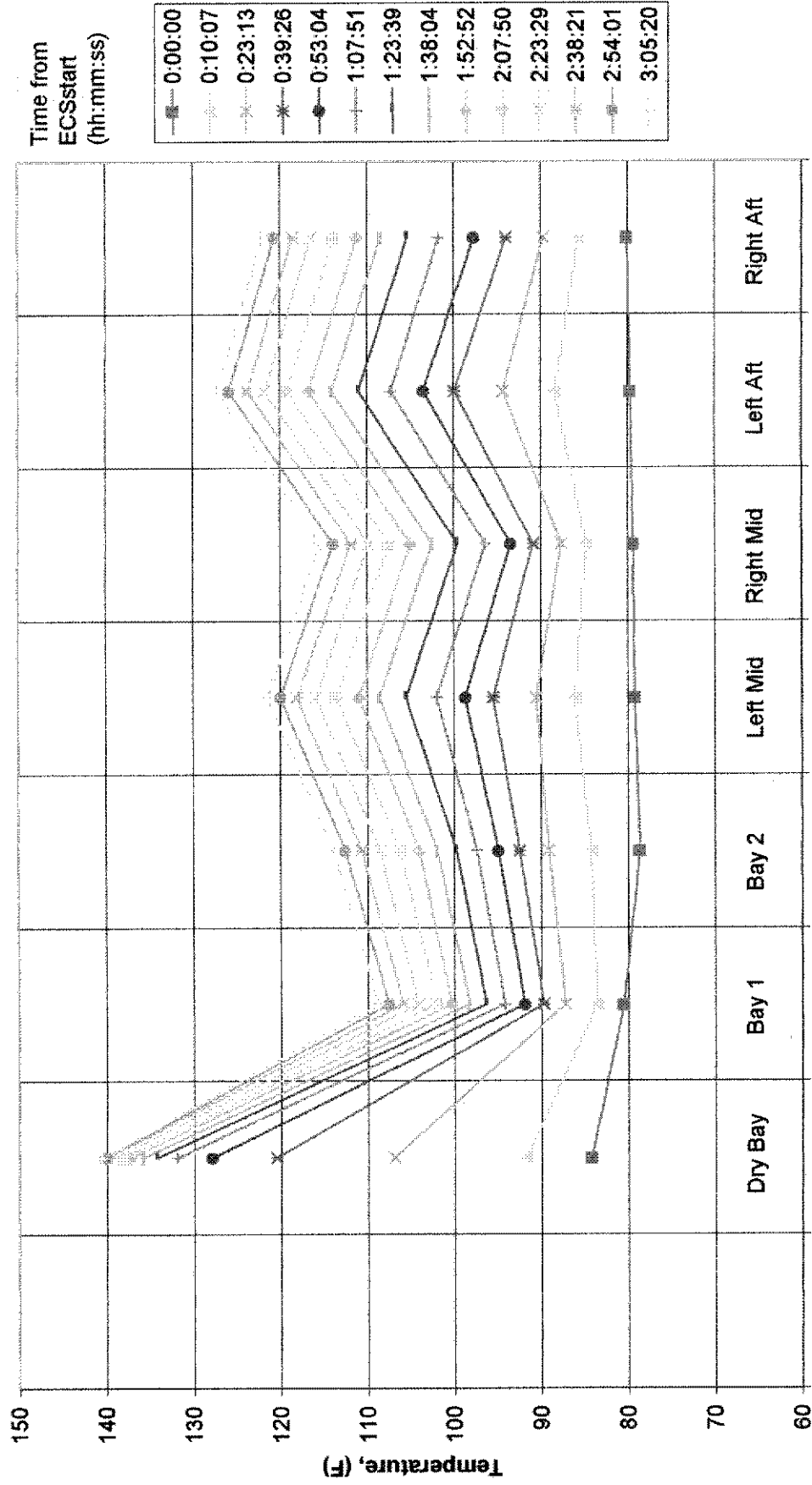

Figure 3.7 CWT bottom internal surface temperatures, Test 3.

Test 1, left built line surface temps

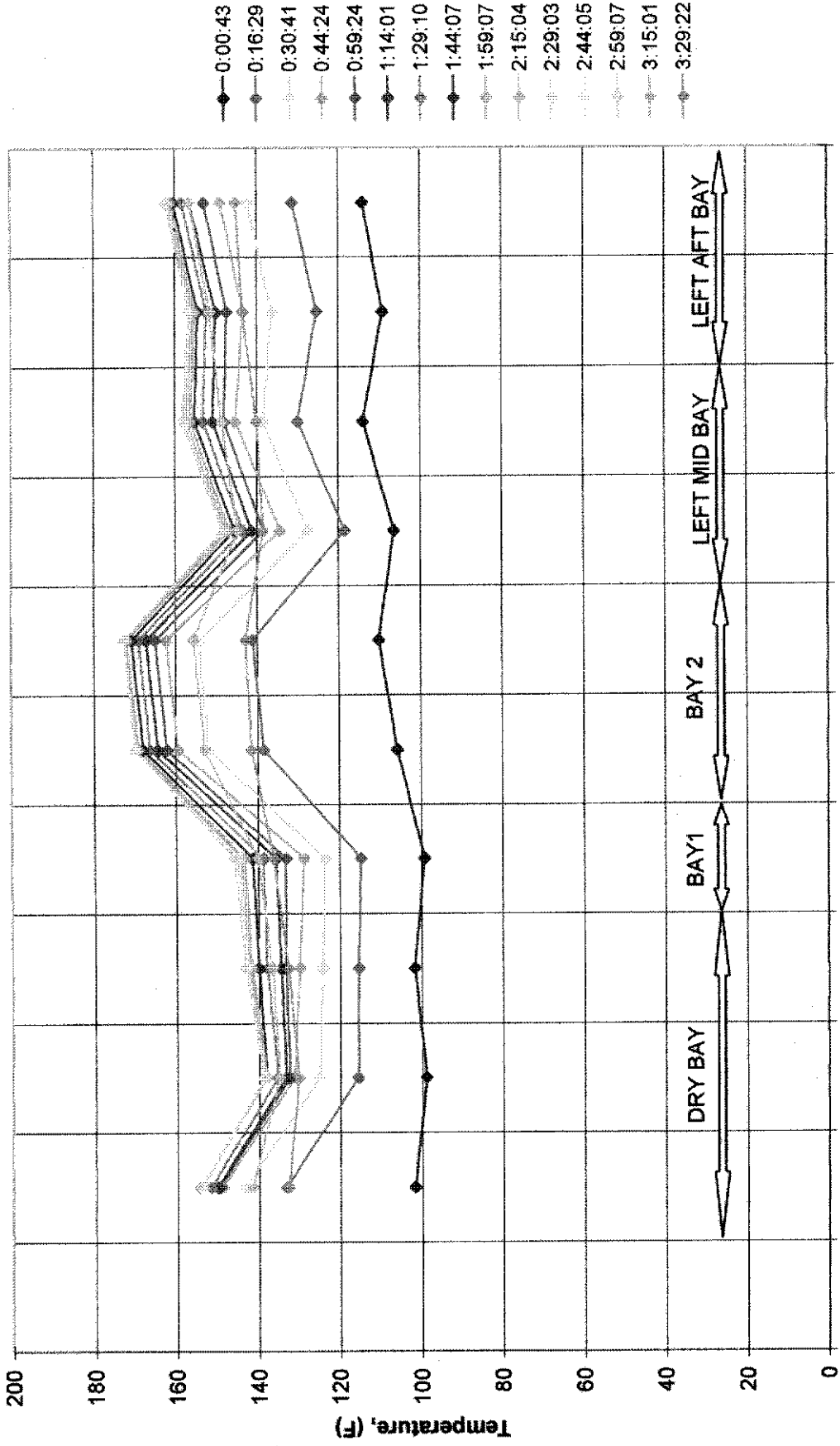

Figure 3.8 CWT bottom external surface temperatures, LBL58, Test 1.

Test 2, left butt line surface cwt

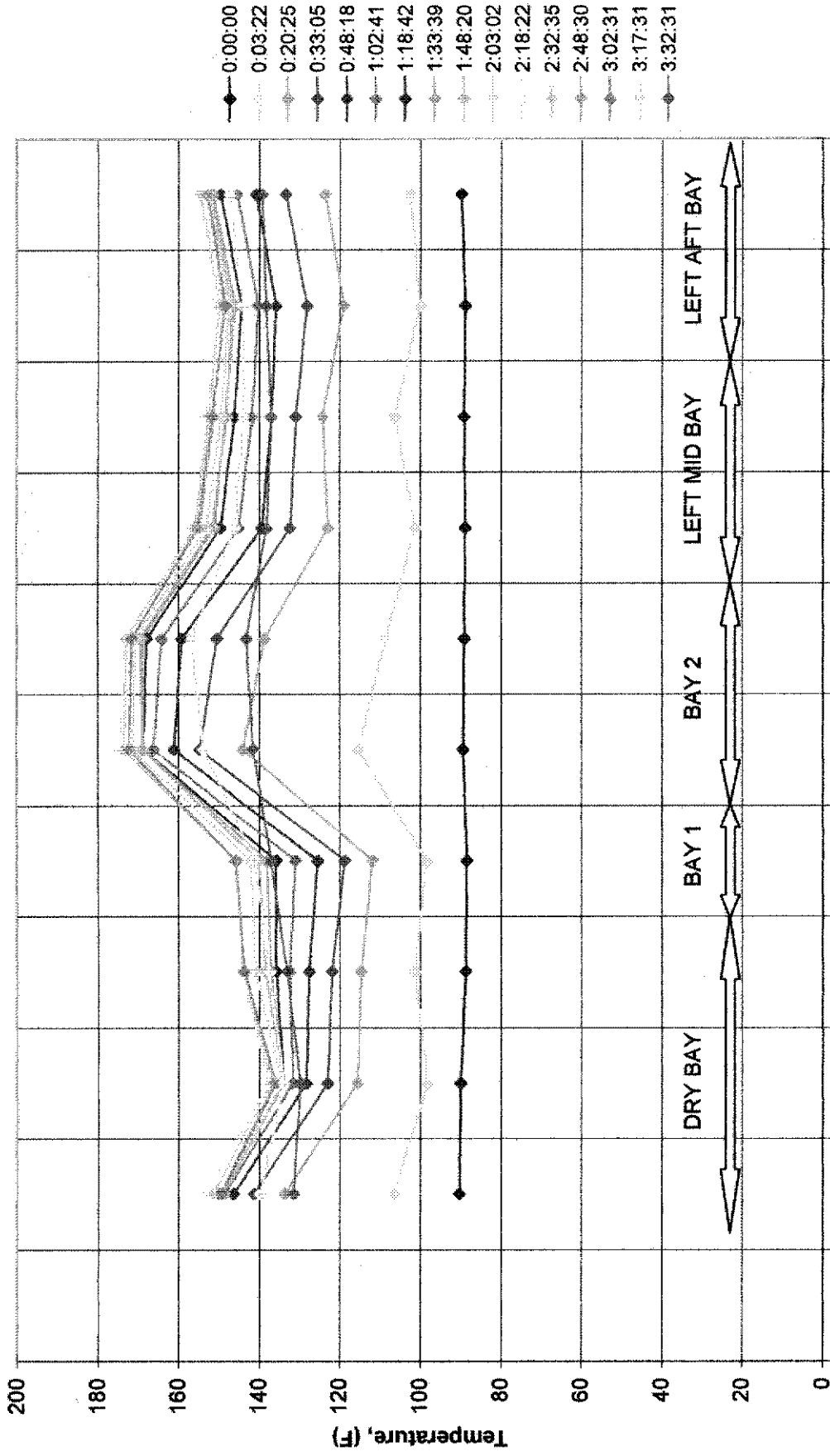

Figure 3.9 CWT bottom external surface temperatures, LBL58, Test 2.

Test 3, left butt line 58 surface cwt

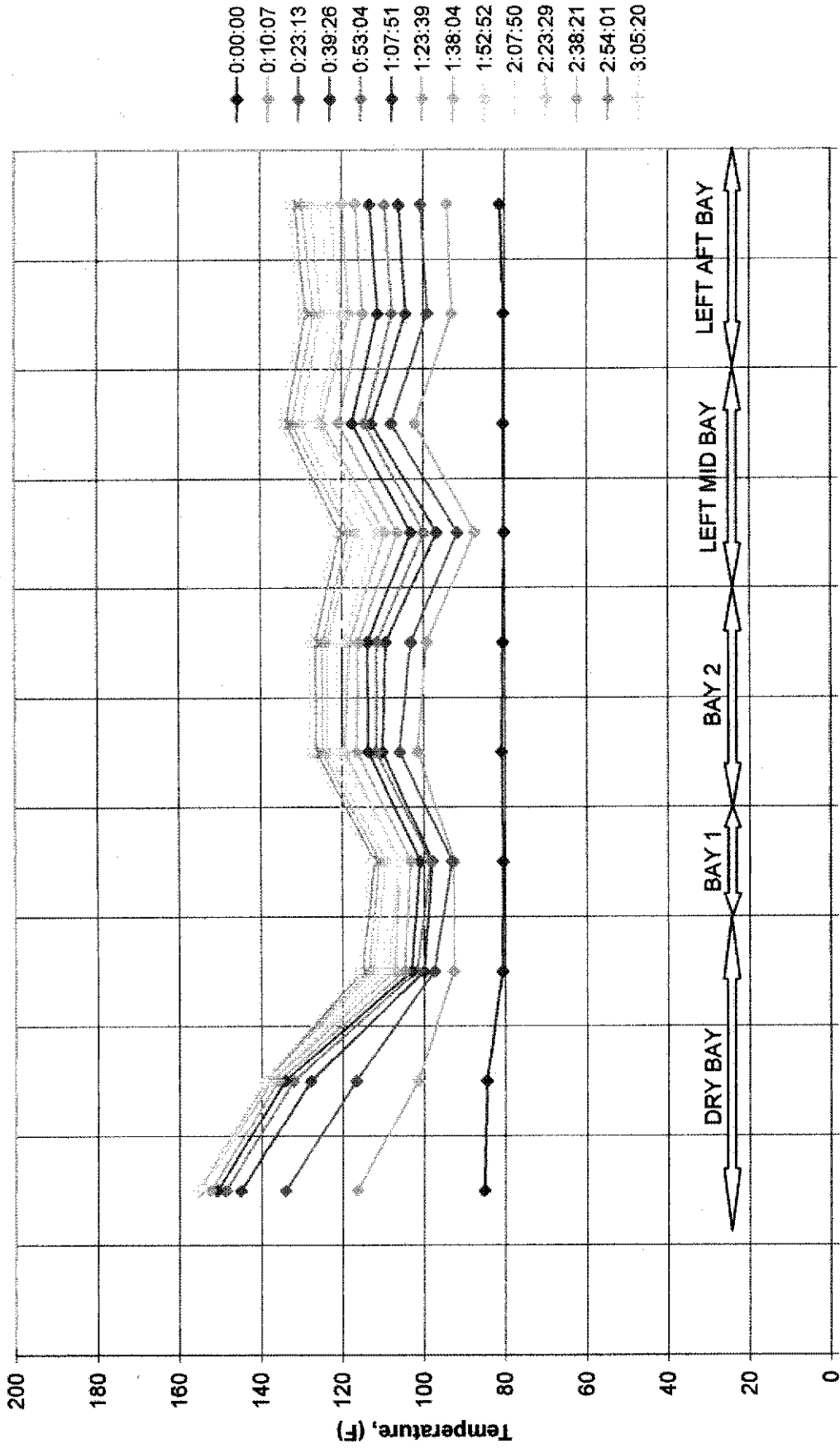

Figure 3.10 CWT bottom external surface temperatures, LBL58, Test 3.

Test 1 Right butt line 58 surface cwt

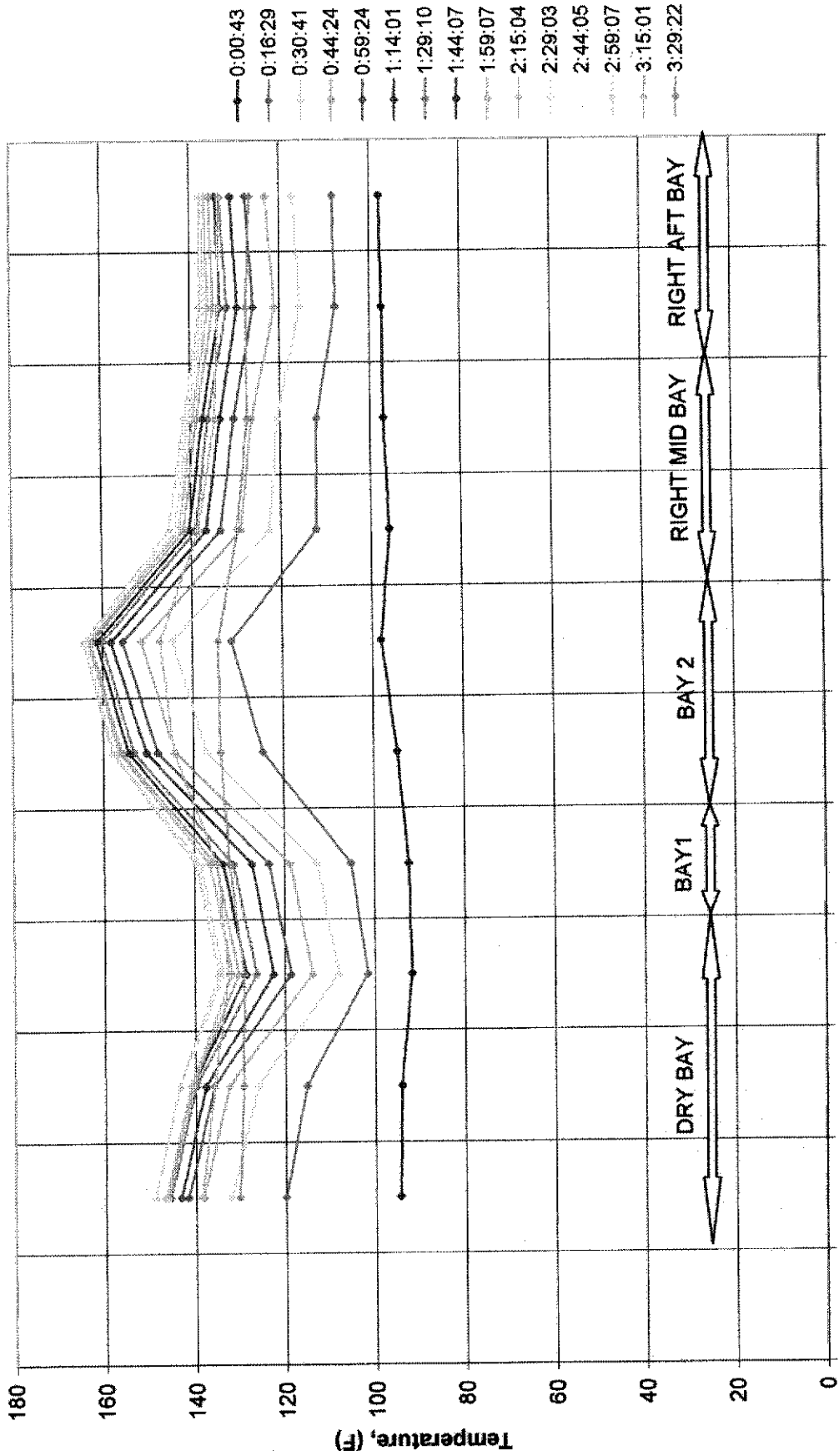

Figure 3.11 CWT bottom external surface temperatures, RBL58, Test 1.

Test 2 Right butt line 58 surface cwt

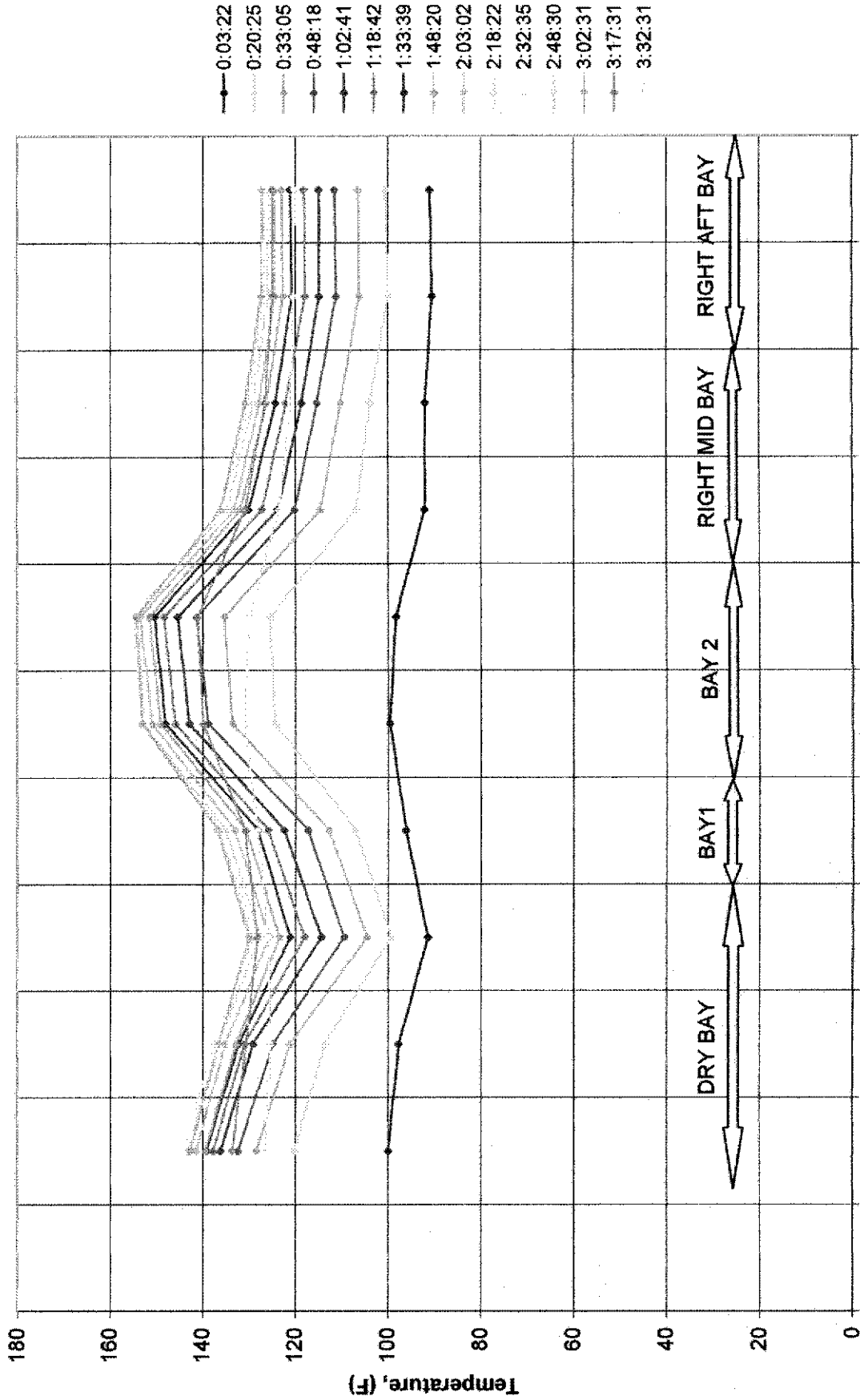

Figure 3.12 CWT bottom external surface temperatures, RBL58, Test 2.

Test 3 Right butt line 58 surface cwt

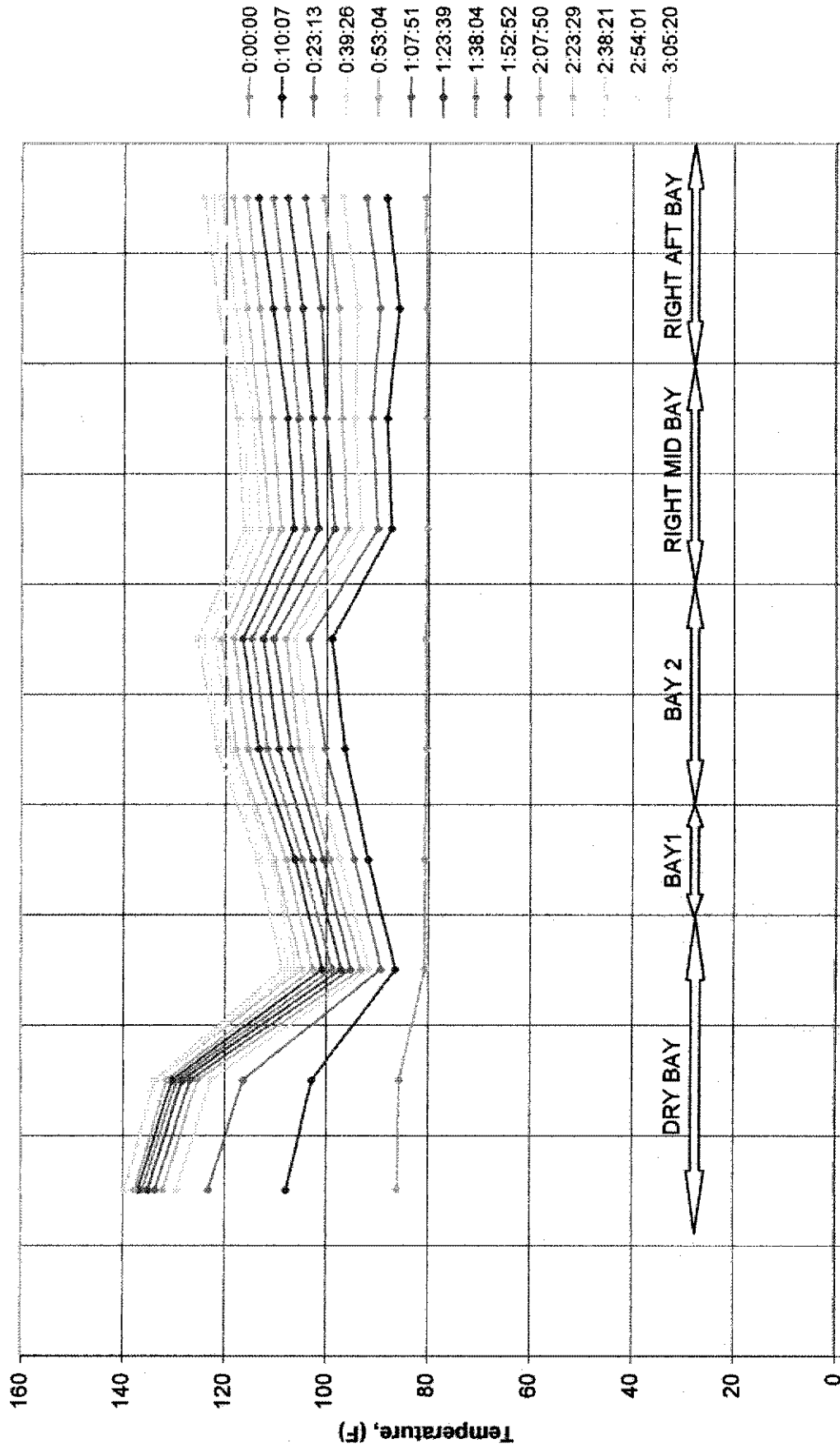

Figure 3.13 CWT bottom external surface temperatures, RBL58, Test 3.

Test 1
ECS Component Surface Temperatures

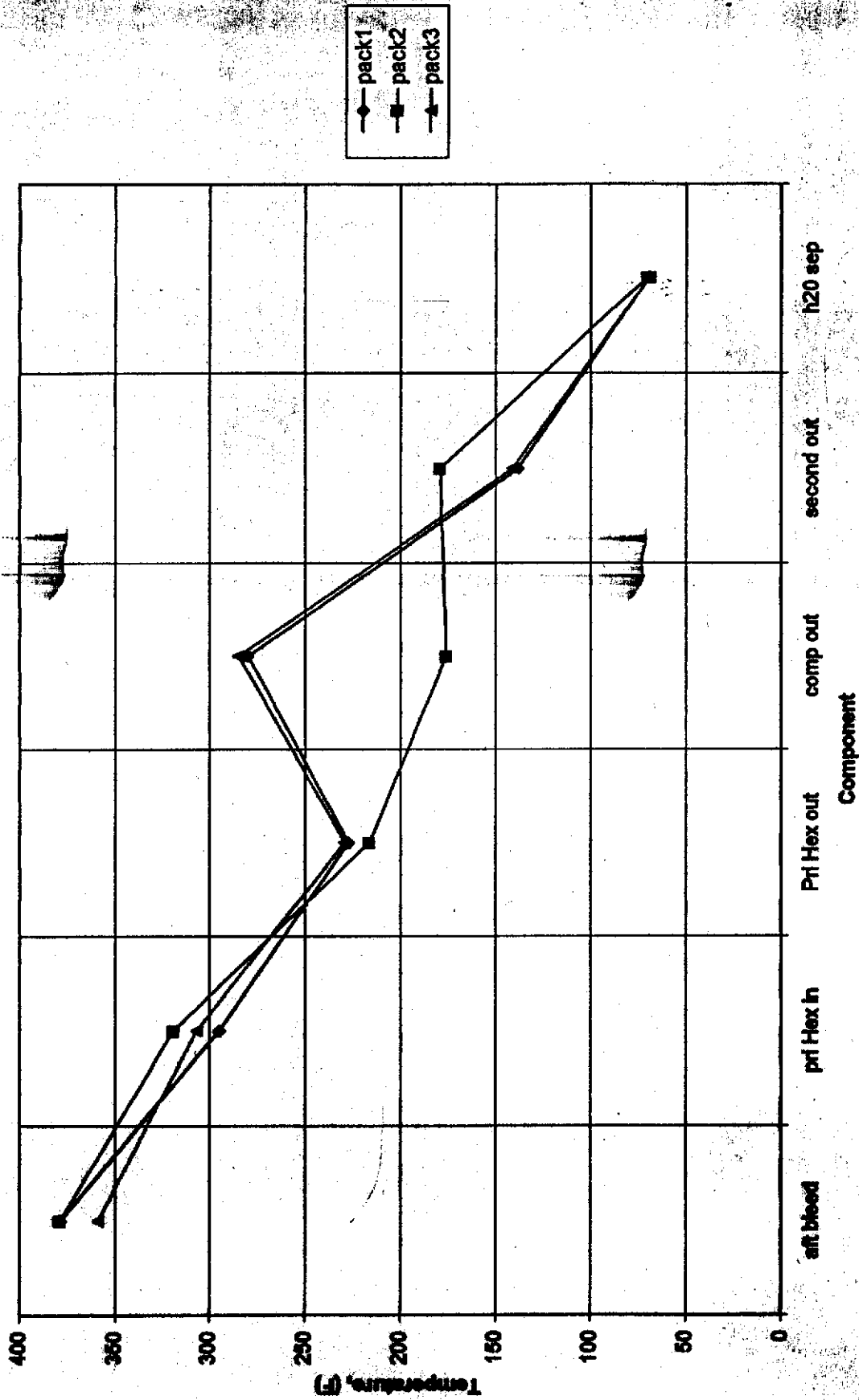

Figure 3.14 ECS component temperatures, Test 1.

Test 2
ECS Component Surface Temperatures

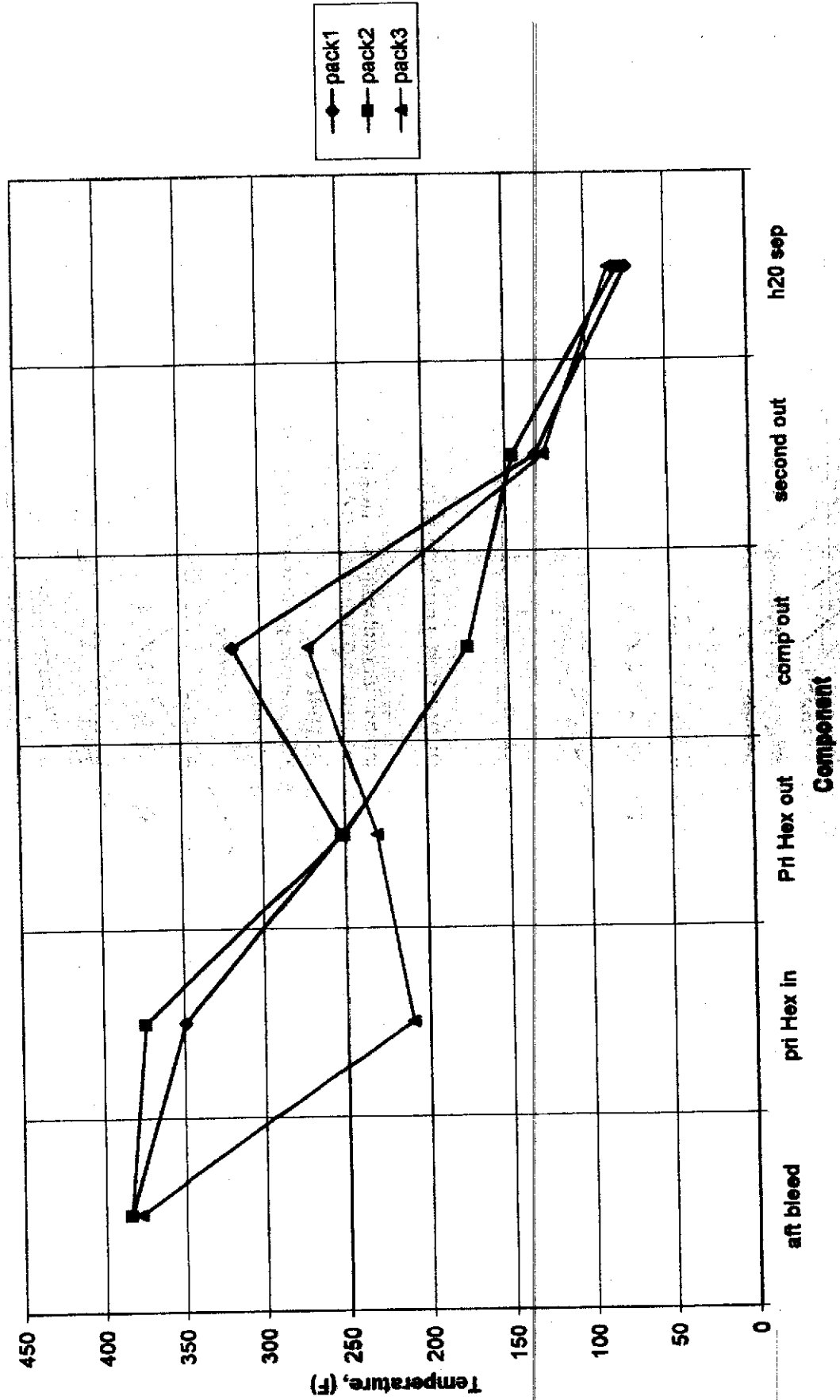

Figure 3.15 ECS component temperatures, Test 2.

Component Temperatures, Test 2

Test 3
ECS Component Surface Temperatures

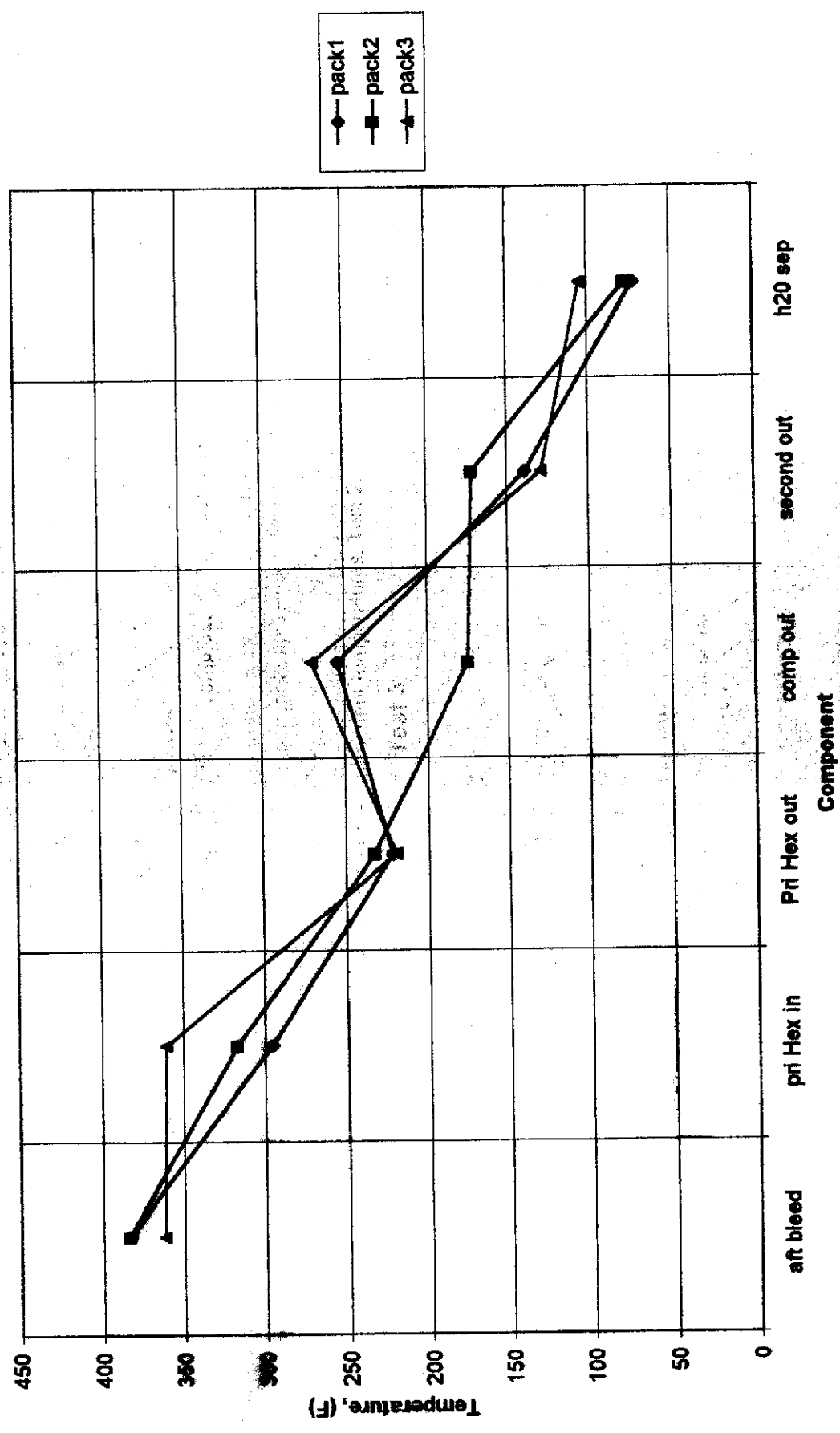

Figure 3.16 ECS component temperatures, Test 3.

Appendix A

Infrared Imaging and Temperature Measurements Under a Boeing 747 Center Wing Tank

Infrared Imaging and Temperature Measurement under a Boeing 747 Center Wing Tank

R. Akbar, P. Svitck, C. Nuyt and J. E. Shepherd

Graduate Aeronautical Laboratories
California Institute of Technology
Pasadena, CA 91125

March 11, 1999

Explosion Dynamics Laboratory Report FM99-3

*Prepared for and supported by the National Transportation Safety Board
Under Order NTSB12-97-SP-0127*

1 Introduction

The tests which are reported here are part of the National Transportation Safety Board (NTSB) investigation on the crash of a commercial airplane Boeing 747 operated by TWA as Flight 800¹. These tests were performed on an aircraft operated on the ground. The purpose of the tests were to determine the thermal environment and the vapor conditions around the center wing tank (CWT) of a B747 with the air condition units in operation. The on-site part of this project was realized at Pinal Air Base (Marana, AZ). The staff of the Explosion Dynamics Laboratory (EDL) of CALTECH collaborated with teams of Boeing and of the Desert Research Institute (DRI) from University of Nevada (Reno, NV). The EDL team took infrared images (IR-images) of the machinery under the CWT and the DRI team worked on sampling vapors from the CWT while the Boeing team operated the systems of the aircraft. The present text is a brief factual report on EDL operations during those ground tests on May 29 through 31 1998. The vapor sample analyses by DRI are reported by J. Sagebiel².

The overall purposes of the tests were to map the ranges of heat generated underneath the CWT and to measure the vapor concentration above the fuel in this tank. EDL had two objectives at the testing site. The first was to assist in the installation and use of a heating system attachment to the pre-existing vapor sampling apparatus used by team DRI. The second objective was to take IR-images of the air conditioning machines (ACM) in order to measure the surface temperature of the three packs and their elements. The ACM bay is located right under the CWT. Images were taken both with and without the packs running.

2 Heating of the Vapor Sample Lines

Air samples of each bay of the CWT were collected in order to analyse their jet fuel composition. The points of collection were located near the center of each bay. In one bay (the middle one), two more samples were taken from a lower and a higher location. Only 50 gallons of fuel were in the CWT in order to simulate a nominally empty tank. Lines were connecting the inside of CWT to sampling bottles. Heating of the vapor sample lines was considered in order to preserve the nature of the samples. On site discussions with Boeing, though, determined that the heating was undesirable at this late a stage in test preparation, and at best was acceptable only outside the aircraft, due to safety concerns. Thus the heating was applied to the copper lines from the sampling bottles right up to the side of the aircraft where the lines penetrated the skin. This was considered an adequate compromise, as the dry bay heated up by midday (typical test start time was 1 pm and temperature in the shade was around 95°F during all three tests), and was expected to heat up even further, once the packs were started. This made the section of the vapor lines external to the aircraft, the coolest and therefore a likely place for condensation to occur.

The equipment for heating consisted of heating tape, a temperature controller, a relay, and two thermocouples. The first thermocouple was closest to the bottles, and the second thermocouple was in the dry bay where the vapor sampling lines fanned out before penetrating spanwise beam 3 (see Figure 1). Feedback to the temperature controller was provided by the first thermocouple, and the controller actuated the relay that, in turn, switched the heating tapes on and off. The controller consistently kept the temperature of the heated section between 140°F and 160°F. A handheld thermocouple probe was used to obtain additional measurements near the bottle furthest from the heater as well as near the point where the lines penetrated the aircraft skin. Aluminum foil was wrapped on the lines for uniformity of heating. Boeing allowed Raza Akbar to operate the temperature controller and take measurements, although Boeing personnel installed the equipment. Tables 1 and 2 show the temperature measurements taken at the first and third tests respectively (no vapor samples were collected during the second test).

¹The aircraft was a Boeing 747-131, N93119. The accident occurred on July 17 1996, East of New York, NY.

²"Analysis of Vapor Samples Collected from the Center Wing Tank of a Boeing 747-100 Aircraft during Ground Tests", prepared by J.C. Sagebiel of Desert Research Institute, University of Nevada, for the National Transportation Safety Board (October 1998).

3 Imaging

An infrared (IR) camera was used for surface temperature measurements. It was a Prism DS IR camera rented from FLIR Systems (Portland, OR). This type of camera has a focal plane array system. The temperature it can read ranges from -10°C to 450°C (15°F to 840°F) and the user can set the emissivity between 0.05 and 1.0 with increments of 0.01. The camera has a video output, as well as a digital storage capability for single takes. The camera was not available for the first test. On the day of the second test, images of the ACM bay exterior were taken as a practice dry run. It was estimated that a few minutes would be required to image any given section. This is because, subsequent to the IR, a sweep of visible video was needed to assist in image identification during post-processing. An imaging time estimate of 60 min. with packs off, and about 30 min. with packs on was submitted to Boeing on the morning of the third test, along with a brief outline of procedure.

During the imaging, the video recorder ran continuously, with the line being attached alternately to the IR camera and the visible video camera. As a particular section was imaged, handheld thermocouple probes were used to get temperature readings for comparison with those obtained from the IR camera. Mark Ahler of Boeing also took temperature readings of the target objects. It was found that the response of the hand held probe was slow, and even the quicker one (Boeing's) was not stationary in output (indicated temperature was typically rising). The temperature data from IR camera and the handheld probes is given in Table 3 along with the description of the IR-images that were taken during this third test. Photos of typical assets of the ACM bay are shown on Figure ref-stillphotos and the layout mapping the locations of the IR-images is at Figure 3. The IR-images themselves are in Figures 4, 5 and 6.

4 Post Processing

The settings on the IR camera were fixed during the testing, for ease of use. The most important of these is the emissivity, which directly affects the temperature readings. Although the value of emissivity used (0.95) is typical of painted surfaces, it is necessary to estimate of the change in temperature with variation in emissivity (representative of the surfaces imaged). This is to be done using post-processing software that operates on the digitized single takes from the IR camera. The software used for that purpose was the Irwin OLE Software (also rented at FLIR Systems). This was the way the temperatures were determined at precise locations on the IR images. Another set of temperature were also produced considering the hypothesis of an emissivity of 0.5. The two series of temperatures at each of the five points on the IR images are listed on Table 4 for the part of the tests when the packs were off and at Table 5 when they were on.

Table 1: Temperatures observed during the first test.

Time	T ₁ [°F]	T ₂ [°F]	T _{amb} [°F]	T _{bottle end} [°F]	Notes
13:55	149	89.6	93	93	Time by observer watch
14:25	150	91.6	93	93.4	
14:41	158.5	93.4	94.8	95	Packs started
14:56	150	98.6	93.4	93.6	
15:11	154	104.8	96	97.6	T _{exit} (from aircraft) at about 105 ° F
15:26	160	107	96	96	120 ° F near bottles. from exhaust gusts
15:41	160	111	94	94	First Sample
15:56	146	112	95	95	
16:11	144	112	121	113	Exhaust gust in the vicinity of bottles
16:26	156	114	96	95	
16:41	160	114	96	95	Second Sample
16:56	148	114	110	104	T _{exit} (from aircraft) at about 108 ° F
17:11	139	114.4	103	99	Exhaust gust in the vicinity of bottles
17:26	152	115	96	96	
17:41	142	115	96	96	ACM shutdown at 5:46 pm (17:46)

Table 2: Temperatures observed during the third test.

Time	T ₁ [°F]	T ₂ [°F]	T _{amb} [°F]	T _{bottle and} [°F]	Notes
13:05	123	88	93	92.6	Heater on. Test started at 1 pm (13:00)
13:25	163	94	92	102	Exhaust gust near bottles
13:35	144	98	103	108	Bottle lines are hot!
13:50	147	103	92.4	93	
14:06	154	106	94	96	112 °F at T _{exit}
14:20	144	107	101	107	
14:35	142	108	104.4	105	
14:51	145	110	99	99	
15:05	156	111	93	94	
15:20	153	112	98	96	111 °F at T _{exit}
15:35	152	112	95	95	
15:51	151	113	95	94	
16:00	160	113	94	94	115 °F at T _{exit}

Table 3: IR-images identification and temperatures at center of each one (test no.3).

Time	Shot #	Location in ACM bay	Emissivity	IR Temp [°F]	Handheld (EDL) [°F]	Handheld (Boeing) [°F]
	d3im1	Pack 2 Flow control valve (silver surface)	0.95	255	180	-
	d3im2	Pack 2 Rear bleed duct (grey surface)	0.95	235	174-196	-
	d3im3	Pack 2 Compressor (inlet silver)	0.95	165	135	135
	d3im4	Pack 2 Turbine	0.95	145	131	127
	d3im5	Pack 2 Fan (non metal surface)	0.95	128	100	103
	d3im6	Pack 1 Flow control valve (grey)	0.95	140	121	136
	d3im7	Pack 1 Compressor (dirty grey)	0.95	124	110	123
18:35	d3im8	Pack 1 Turbine (silver)	0.95	126	110	117
	d3im9	Pack 1 Fan	0.95	111	96	101
	d3im10	Pack 3 Flow control valve (silver)	0.95	132	107	126
	d3im11	Pack 3 Bleed duct	0.95	115	101	105
	d3im12	Pack 3 Compressor	0.95	121	110	116
	d3im13	Pack 3 Turbine	0.95	116	105	114
	d3im14	Pack 3 Fan	0.95	110	98	104
	d3im15	Pack 3 Green tank bottom (beside louvres)	0.95	120	-	-
18:55	d3im16	Pack 1 Tank bottom near heat exchanger radiometer	0.95	188	-	-
	d3im17	Pack 1 Tank bottom beside compressor	0.95	114	-	-
	d3im18	Pack 3 Heat exchanger and tank bottom surface	0.95	113	-	-
	d3im19	Pack 3 Tank bottom (aft)	0.95	116	-	110
17:05	----- Packs turned on -----					
17:17	d4im1	Pack 2 Flow control valve	0.95	over-ranged	-	-
17:20	d4im2	Pack 1 Flow control valve	0.95	over-ranged	-	254
17:22	d4im3	Pack 3 Flow control valve	0.95	over-ranged	-	261
	d4im4	Tank bottom between Packs 1 and 2	0.95	-	-	-
	d4im5	Tank bottom between Packs 1 and 2	0.95	217	-	-
17:28	----- Packs turned off -----					
17:28	d4im6	Pack 3 Junction before flow control valve	0.95	201-190	-	196
	d4im7	Pack 3 Tank bottom (aft)	0.95	122	-	114

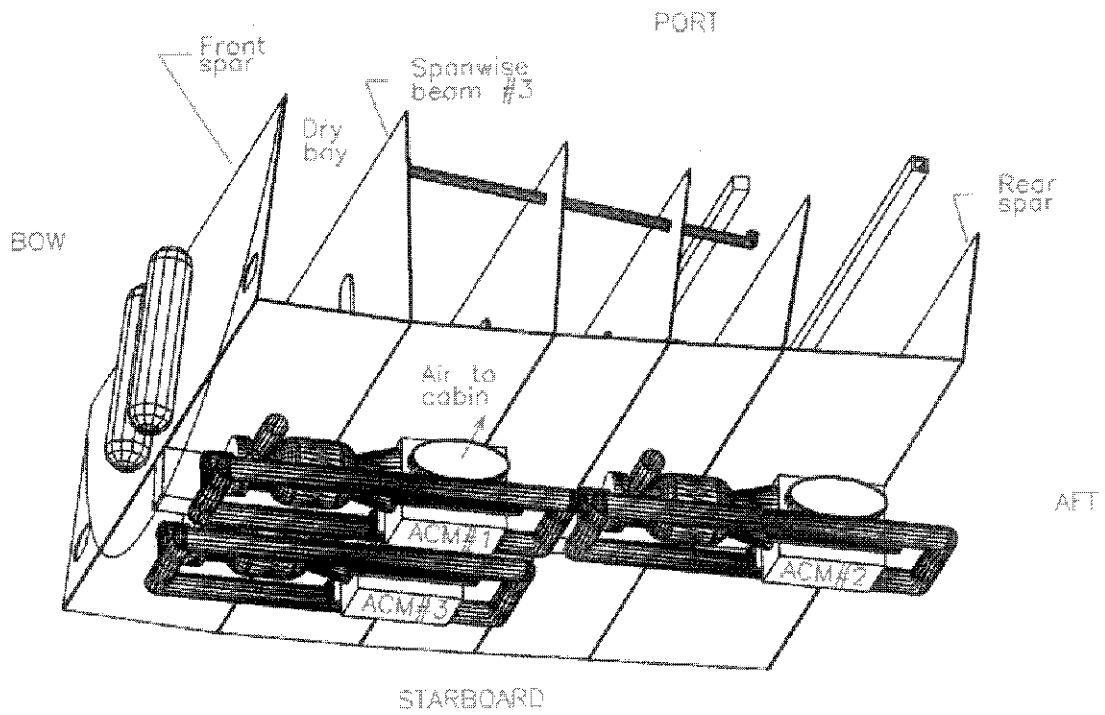

Figure 1: A 3-D schematic view of the tank along with the three ACM underneath it.

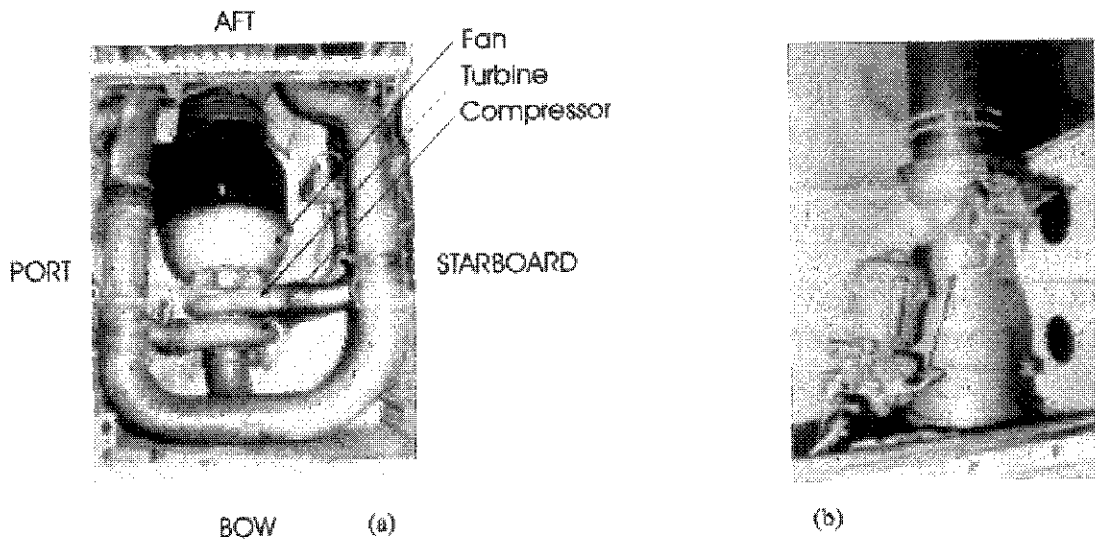

Figure 2: (a) Pack number 1 with parts identified; (b) Flow control valve number 3.

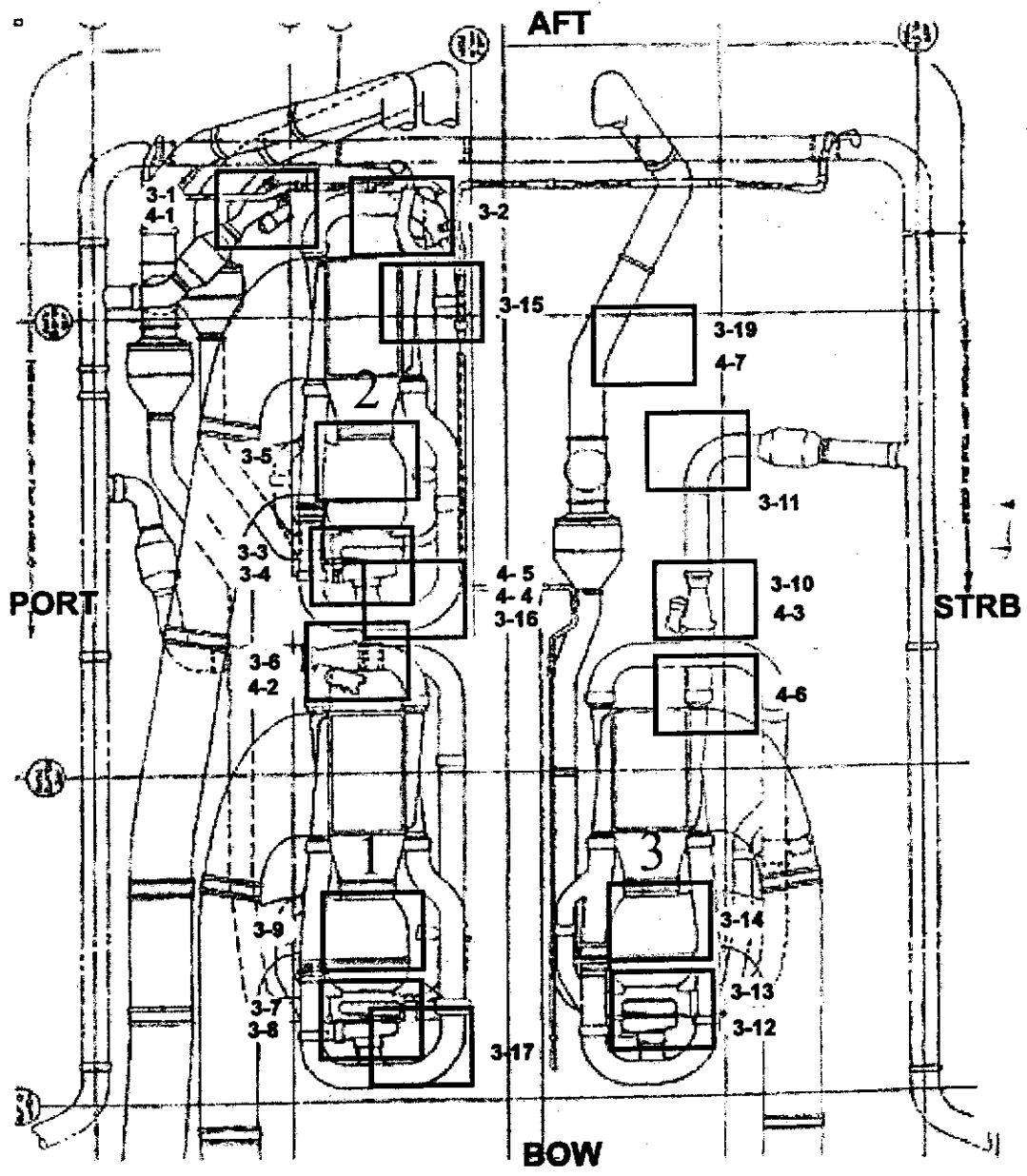

Figure 3: IR-images locations superimposed on schematic of ACM bay equipment (adapted from a Boeing technical drawing). The configuration of ACM bay is as seen from beneath the plane.

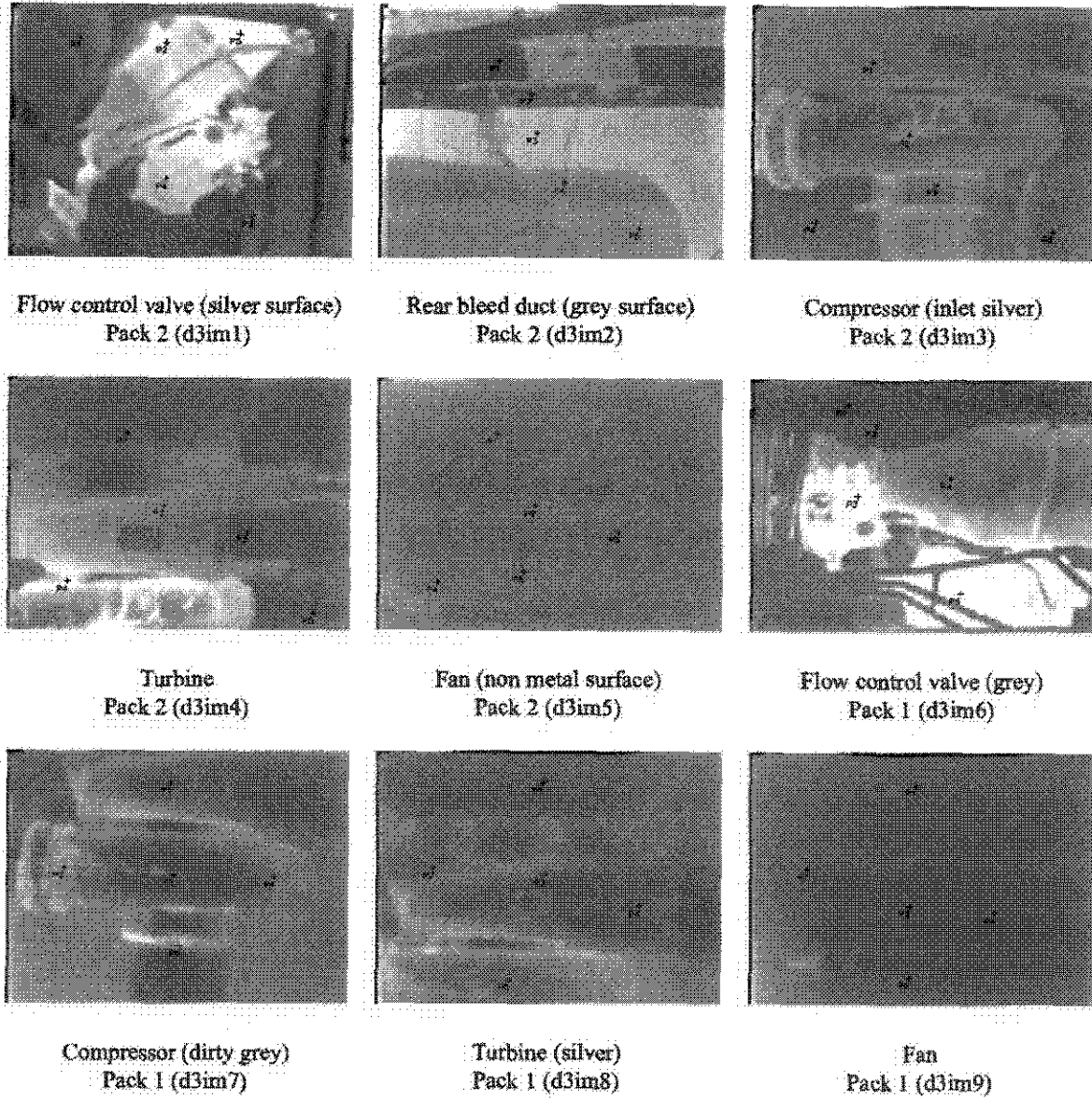
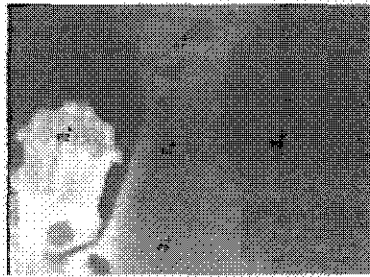
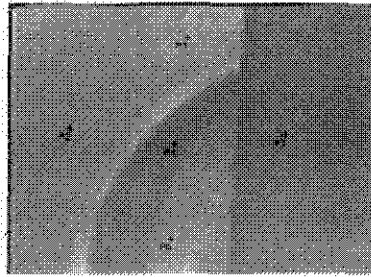

Figure 4: IR-images during cool-off phase (ACM packs off) of test no.3.



Flow control valve (silver)
Pack 3 (d3im10)



Bleed duct
Pack3 (d3im11)

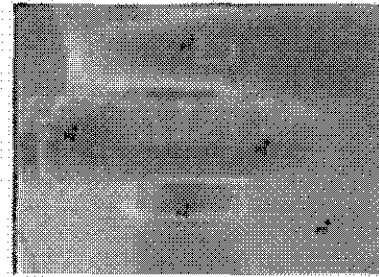

Compressor
Pack 3 (d3im12)

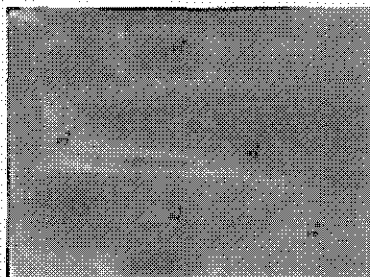

Turbine
Pack 3 (d3im13)

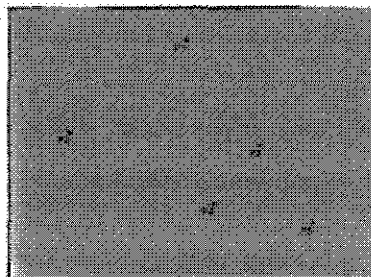

Fan
Pack 3 (d3im14)

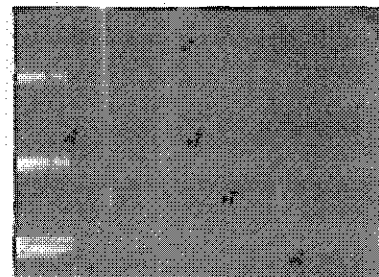

Green tank bottom beside louvres
Pack 3 (d3im15)

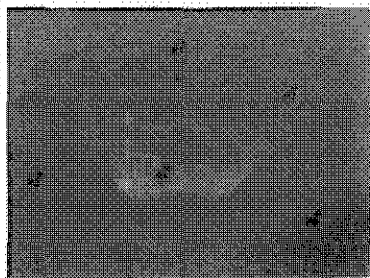

Tank bottom near Pack 1 heat exch.
radiometer (d3im16)

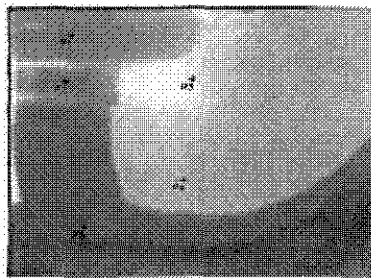

Tank bottom beside compressor
Pack 1 (d3im17)

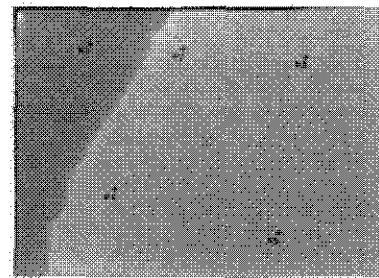

Tank bottom surface; aft
Pack 3 (d3im19)

Figure 5: IR-images during cool-off phase (ACM packs off) of test no.3...continued.

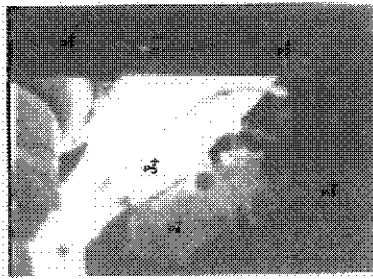

Flow control valve
Pack 2 (d4im1)

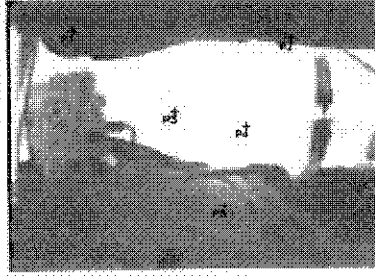

Flow control valve
Pack 1 (d4im2)

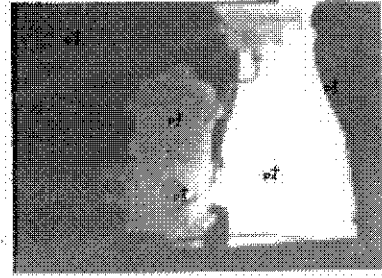

Flow control valve
Pack 3 (d4im3)

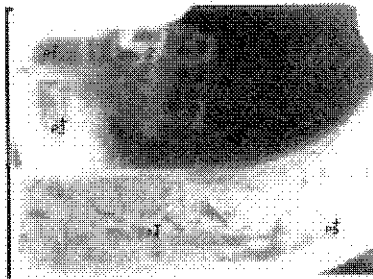

Tank bottom between
Packs 1 and 2 (d4im4)

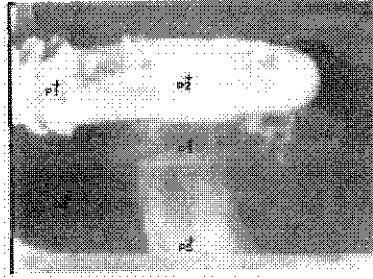

Tank bottom between
Packs 1 and 2 (d4im5)

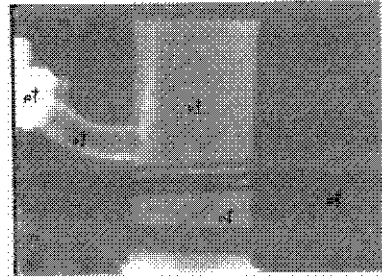

Junction before flow control valve
Pack 3 (d4im6)

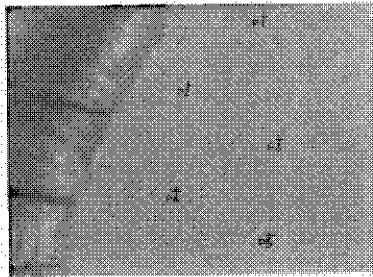

Tank Bottom; aft
Pack 3 (d4im7)

Figure 6: IR images with ACM packs on during test no.3.

Table 4: Temperature readings at points identified on images; series with ACM packs off (during cool-off phase of test number 3)

Image #	P1 [F]	P2 [F]	P3 [F]	P4 [F]	P5 [F]	Emissivity set to
d3im1	191.06	259.67	185.94	238.01	262.42	0.95
	233.98	319.1	227.48	292.55	322.48	0.5
d3im2	160.05	179.37	236.74	187.03	197.5	0.95
	193.74	219.01	290.99	228.88	242.15	0.5
d3im3	157.55	168.94	156.61	145.02	137.32	0.95
	190.38	205.53	189.13	173.36	162.61	0.5
d3im4	135.1	146.17	133	157.39	132.16	0.95
	159.42	174.94	156.42	190.17	155.21	0.5
d3im5	132.09	128.7	127.67	132.56	123.01	0.95
	155.1	150.12	148.61	155.78	141.76	0.5
d3im6	123.1	129.82	159.16	137.97	160.17	0.95
	141.89	151.77	192.55	163.54	193.9	0.5
d3im7	124.64	134.41	126.7	132.38	137.95	0.95
	144.15	158.44	147.18	155.52	163.5	0.5
d3im8	120.28	128.79	128.23	125.95	126.43	0.95
	137.53	150.26	149.44	146.08	146.79	0.5
d3im9	113.03	115.81	110.67	112.99	111.51	0.95
	126.22	130.61	122.3	126.16	123.7	0.5
d3im10	135.06	151.35	118.16	133.76	138.94	0.95
	159.37	182.07	134.25	157.51	164.93	0.5
d3im11	118.05	117.76	115.78	113.47	118.08	0.95
	134.07	133.63	130.55	126.94	134.12	0.5
d3im12	120.77	121.41	121.78	116.72	124.59	0.95
	138.29	139.28	139.85	132	144.08	0.5
d3im13	118.39	123.79	117.77	120.26	120.51	0.95
	134.6	142.91	133.64	137.5	137.88	0.5
d3im14	112.01	113.66	111.94	109.14	113.6	0.95
	124.53	127.27	124.42	119.76	127.16	0.5
d3im15	123.12	115.29	116.15	121.83	114.4	0.95
	141.92	129.8	131.13	139.93	128.42	0.5
d3im16	109.34	110.02	105.99	108.46	105.55	0.95
	120.1	121.22	114.55	118.64	113.82	0.5
d3im17	108.5	109.71	115.03	113.79	107.31	0.95
	118.7	120.72	129.39	127.47	116.74	0.5
d3im18	119.77	115.45	118.89	115.8	114.73	0.95
	136.74	130.04	135.38	130.58	128.93	0.5
d3im19	111.06	117.63	117.78	117.16	115.88	0.95
	113.19	119.59	119.75	119.14	117.89	0.5

Table 5: Temperature readings at points identified on images; series with ACM packs on during test number 3.

Image #	P1 [F]	P2 [F]	P3 [F]	P4 [F]	P5 [F]	Emissivity set to
d4im1	175.06	188.02	181.1	221.49	306.15	0.95
	213.44	230.13	221.25	272.16	375.85	0.5
d4im2	196.09	187.42	262.03	306.15	219.7	0.95
	240.36	229.37	321.99	375.85	269.94	0.5
d4im3	164.76	222.04	232.22	306.15	185.6	0.95
	200	272.84	285.44	375.85	227.05	0.5
d4im4	208.77	234.23	174.98	231.11	242.81	0.95
	256.31	287.93	213.34	284.07	298.43	0.5
d4im5	306.15	306.15	213.93	183.07	255.57	0.95
	375.85	375.85	262.8	223.79	314.07	0.5
d4im6	306.15	194.07	203.19	211.53	172.39	0.95
	375.85	237.8	249.29	259.78	209.99	0.5
d4im7	124.9	125.67	124.64	125.19	125.85	0.95
	144.54	145.67	144.16	144.97	145.94	0.5

Appendix

List of times at which IR and visual images can be found on the video tape taken on May 31 1998 during the test number 3. The video recorder was alternately connected to the infrared and the visual range cameras. The initial time (0h00m00s) is set at the very beginning of the tape.

Image #	IR images Time	Visual images Time
d3im1	0:06:40	0:07:40
d3im2	0:11:00	0:11:50
d3im3	0:15:00	0:15:40
d3im4	0:17:00	0:18:00
d3im5	0:19:00	0:20:00
d3im6	0:21:40	0:22:40
d3im7	0:25:20	0:26:00
d3im8	0:27:10	0:27:50
d3im9	0:29:30	0:30:00
d3im10	0:31:10	0:32:00
d3im11	0:33:30	0:34:20
d3im12	0:36:10	0:36:50
d3im13	0:38:00	0:38:50
d3im14	0:40:00	0:40:50
d3im15	0:42:20	0:43:30
d3im16	0:44:50	0:45:40
d3im17	0:47:00	0:47:40
d3im18	0:50:00	—
d3im19	0:53:25	—
d4im1	0:55:50	—
d4im2	0:57:20	—
d4im3	1:00:00	—
d4im4	1:02:00	—
d4im5	1:02:30	—
d4im6	1:06:10	—
d4im7	1:10:30	—