

Docket No. SA-534

Exhibit No. 2-EA

NATIONAL TRANSPORTATION SAFETY BOARD

Washington, D.C.

PG&E MILPITAS AND SCADA DIAGRAMS

(5 Pages)

SAN FRANCISCO - PENINSULA

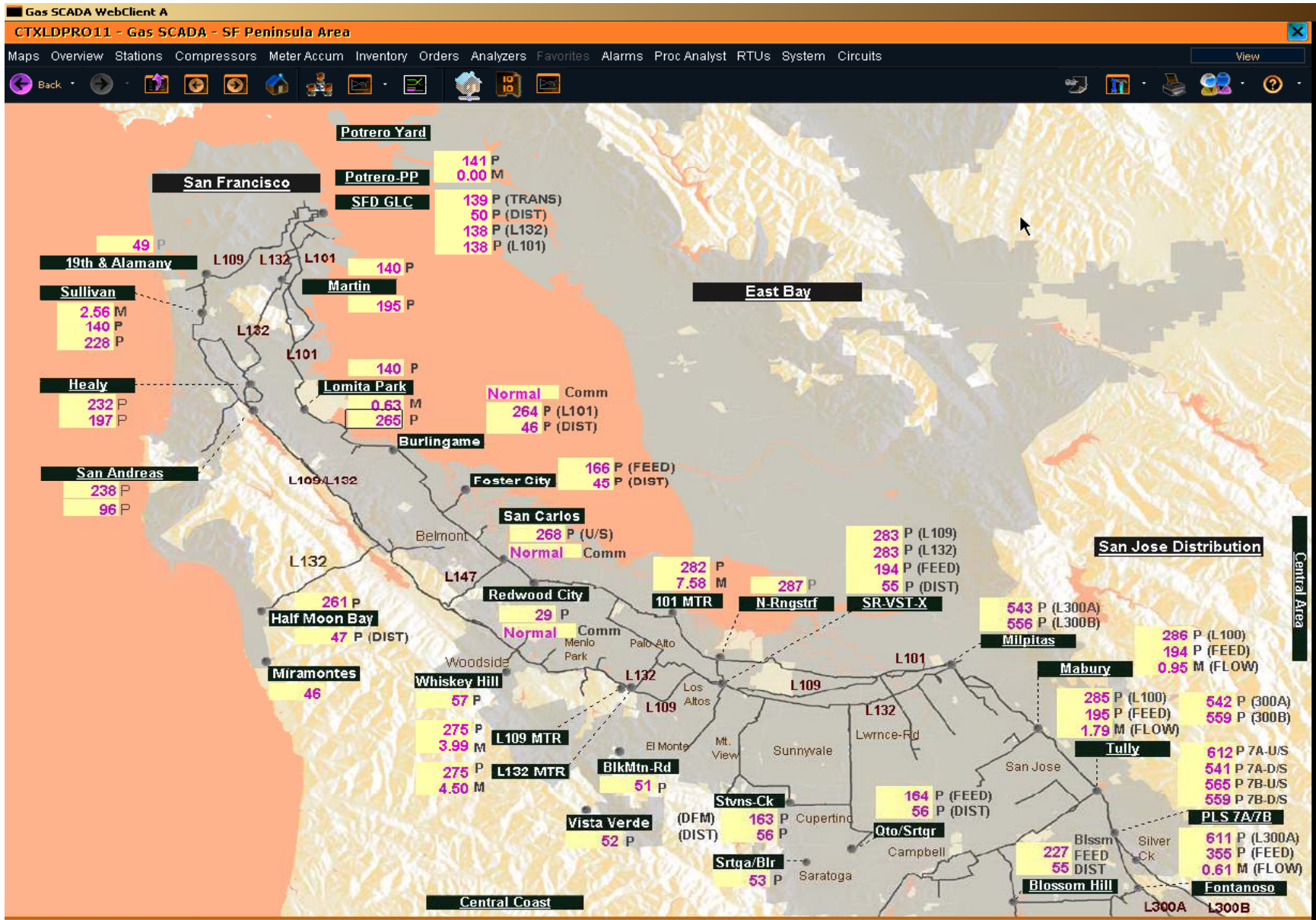

MARTIN STATION

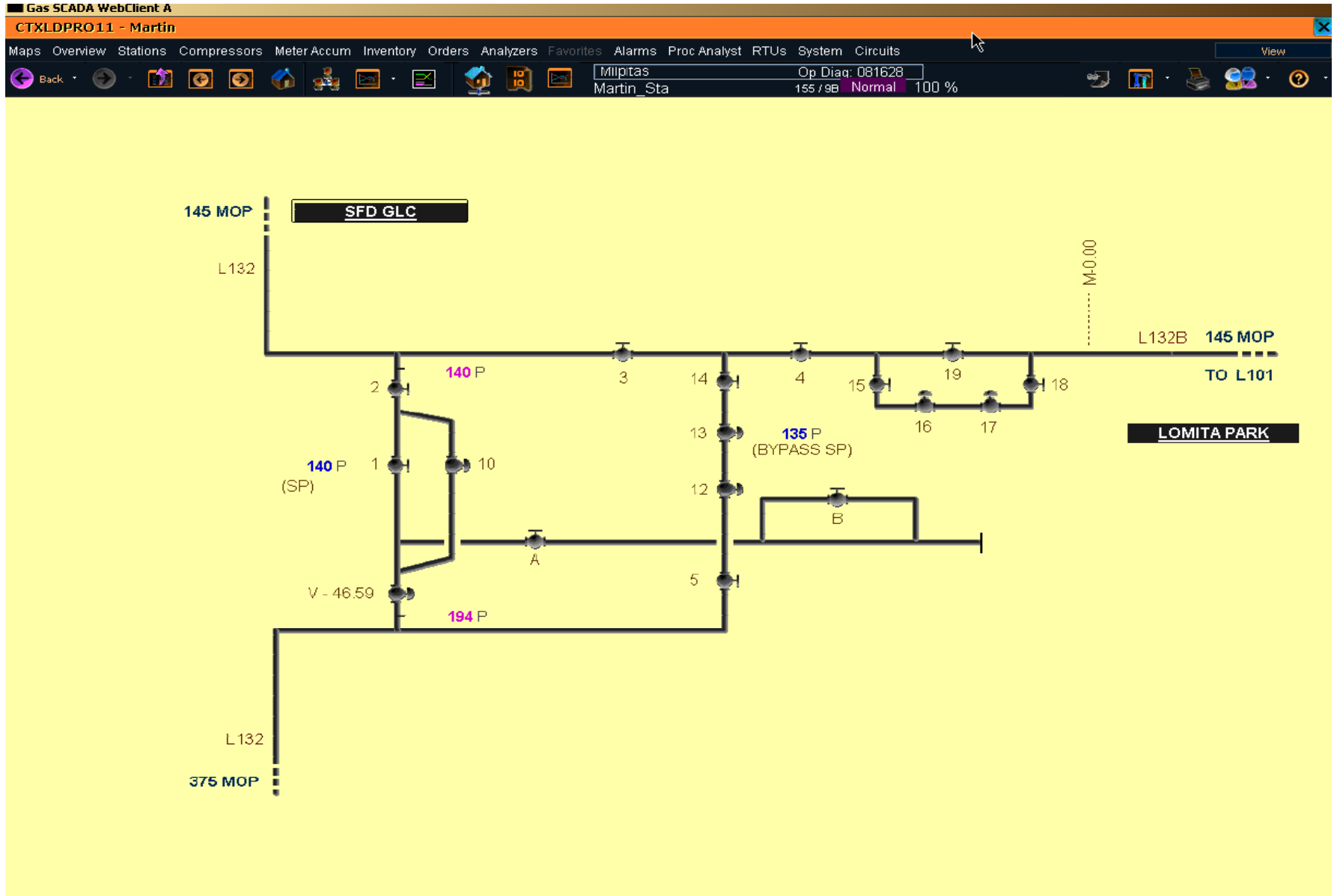

HEALY STATION

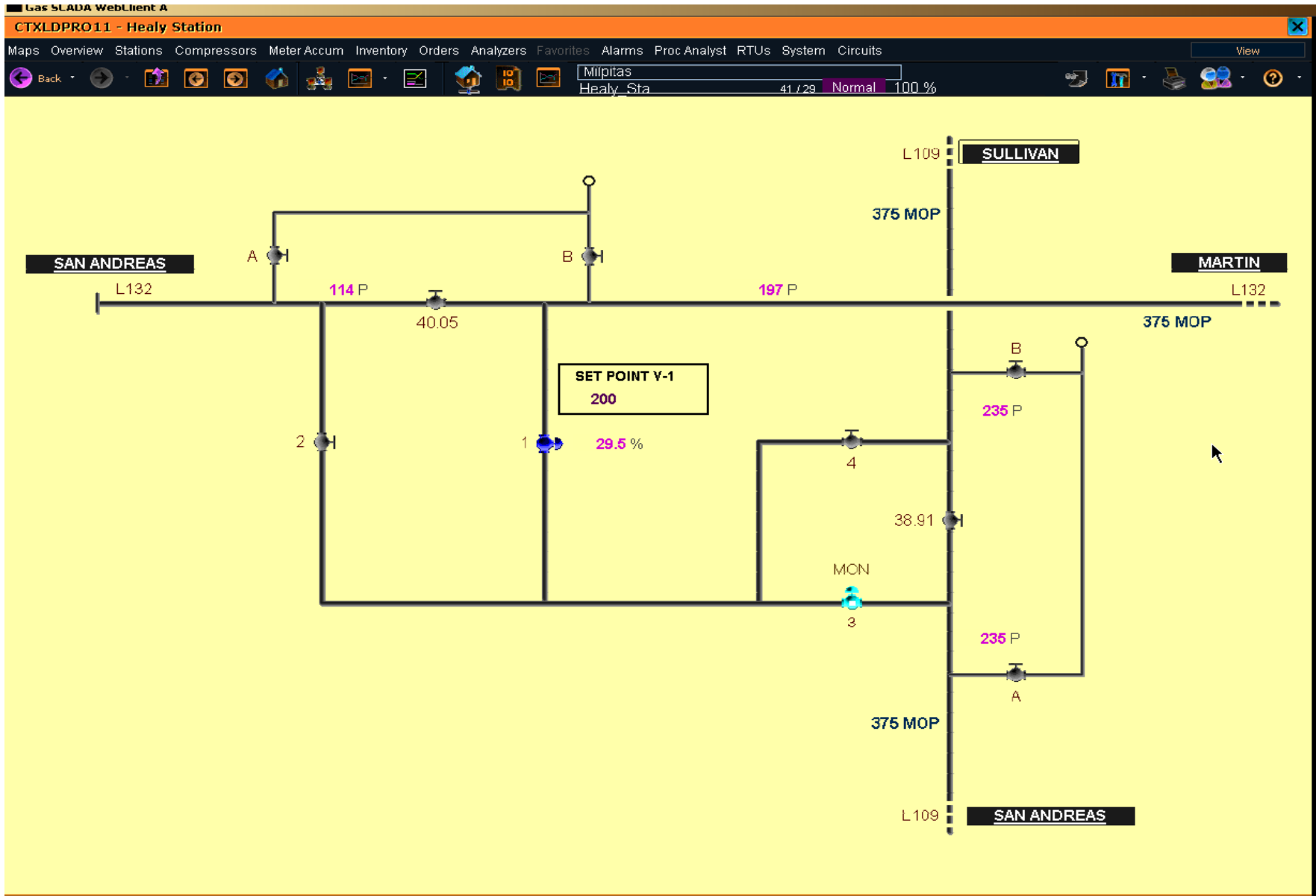

MILPITAS TERMINAL – GAS FLOW DIAGRAM

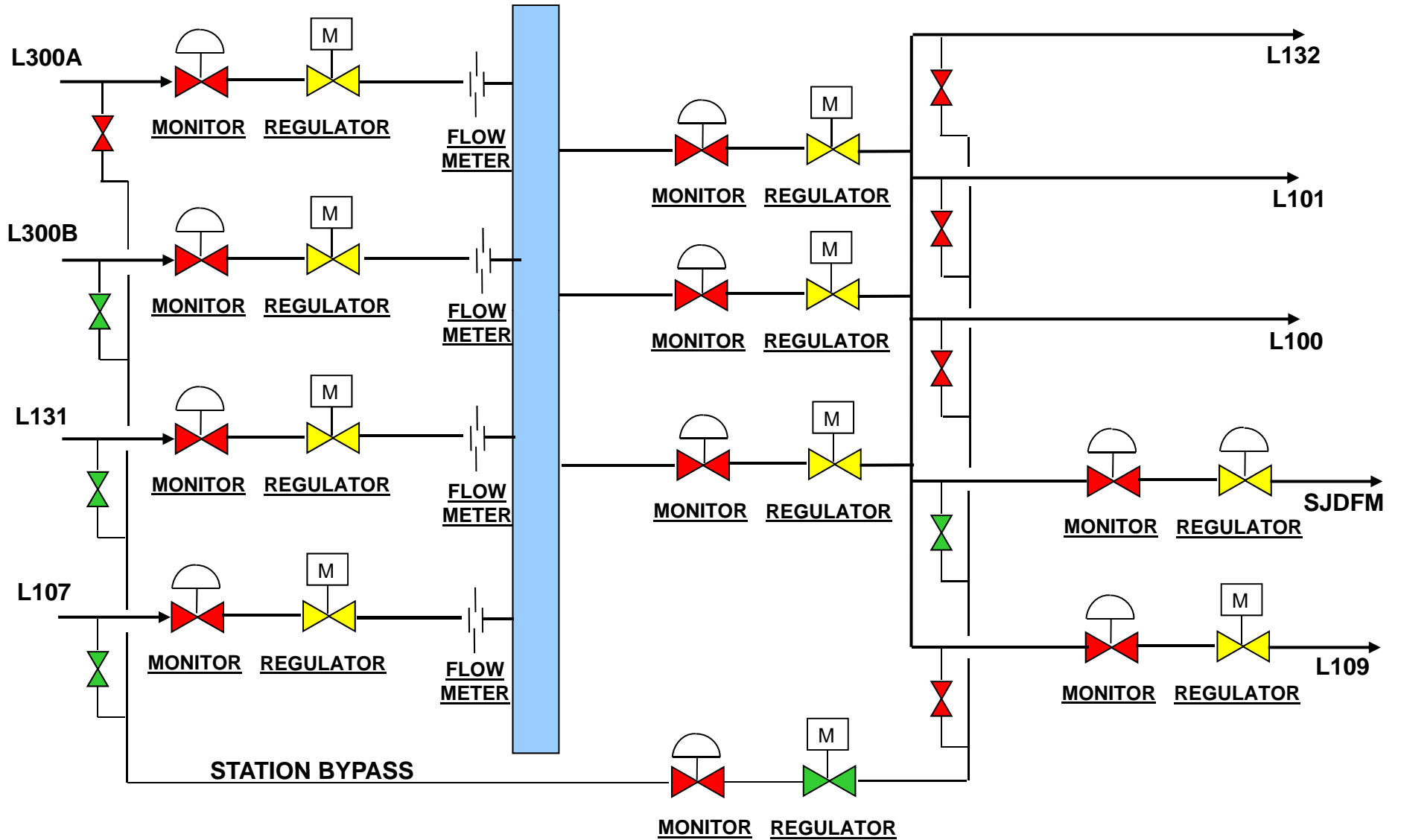

TYPICAL ELECTRICAL SYSTEM WITH UPS

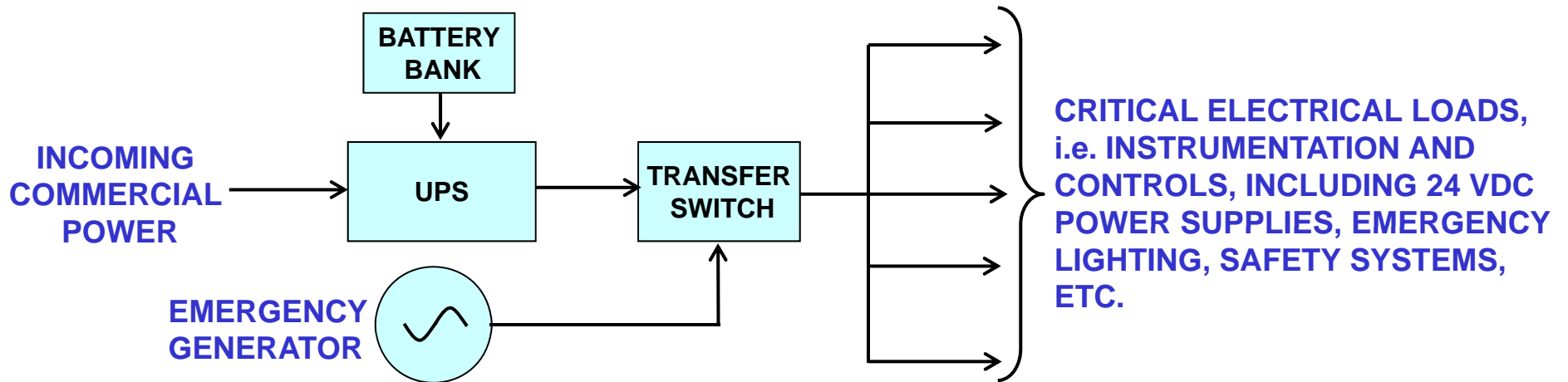

MILPITAS TEMPORARY ELECTRICAL SYSTEM WITH UPS

