

Western-Cullen-Hayes Derails

A derail is a device designed to limit the movement of railroad rolling stock into areas where they could cause personal injury or damage to other equipment or structures. The greatest use of derails is in the area of worker protection. Any time employees are working on the track or in or around rolling equipment, they must be protected by an effective derail. Western-Cullen-Hayes manufactures several styles of derails and accessories for railroad and industrial applications.

WCH Derails function by lifting the flange of the wheel up and deflecting it laterally to drop the wheel clear of the rail head, on the field of the track. Movement of the rolling equipment is halted by the wheels becoming imbedded in the track ballast.

All Western-Cullen-Hayes Derails are light weight, welded alloy steel, designed to give years of effective service at minimal cost.

Model HB Sliding Derails are designed to operate on and off the rail in sliding motion and require an operating stand or other device, such as our ELDO or Delectric, to move them. Model HB Derails can be equipped with circuit controllers for position indication read back, if required.

Model EB Hinged Derails do not require an operating stand of any type to move them. The derail block is lifted by hand in a vertical semi-circle on and off the rail head. Model EB Derails are typically installed on industrial sliding and other light traffic locations. Model EB Derails can be equipped with circuit controllers for position indicator read back, if required.

All Model HB and EB Derails are sized to fit particular rail heights. The size number is stamped on the nameplate and indicates the distance in inches from the top of the rail to the surface on which the derail is secured. To select the proper size derail, simply measure the height of the rail and tie plate, if used. This height may not be in even inches; so to achieve an even numbered height, it may be necessary to shim the derail up or adz the cross tie down. Never shim or adz more than 1/2".

To select a left or right hand stand between the rails; look in the direction of the area to be protected and determine if the rolling equipment should be derailed to the right or left. Remember, a right hand derail will be mounted on the right hand rail and conversely with the left. Derails are always mounted on the gauge side (inside) of the rail.

WESTERN-CULLEN-HAYES, INC.

120 N. 3rd. Street, P.O. Box 756 Richmond, Indiana 47374
(765) 962-0526 FAX (765) 966-5374

Hayes Derails - Model EB/EBX and EBF

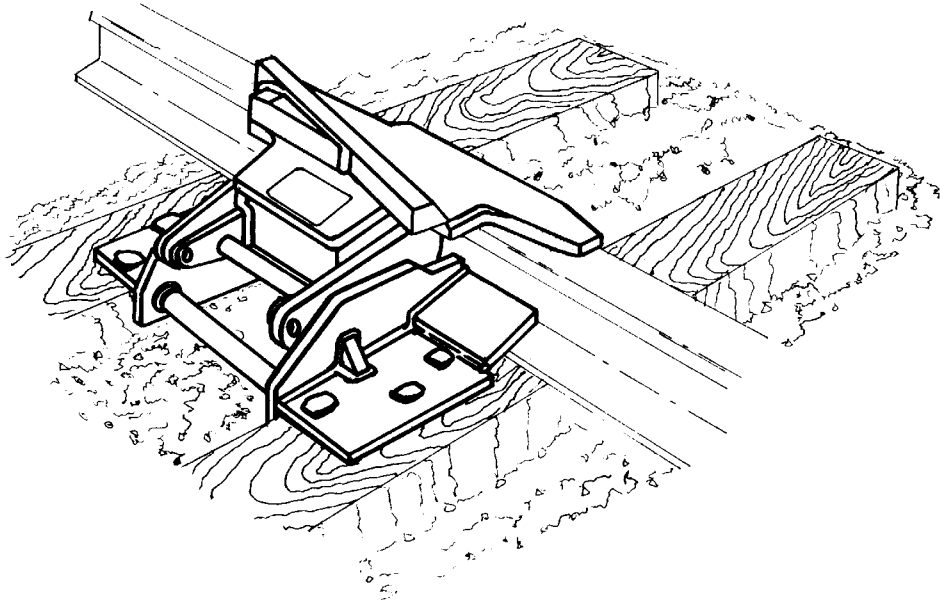

*Model EB Size 6 Open

<u>Model</u>	<u>Sizes</u>	<u>Direction</u>
EB	4,5,6,7,8	Right Hand or Left Hand
EBX	4,5,6,7,8	Double End

Hayes Hinge Derails; Models EB and EBF are for direct by-hand operation only. Hinge derails cannot be thrown by a stand or remote control.

The Hayes Target Stand shown in this section may be used to automatically indicate the derail position when the derail is thrown. For Model EBF the integral flag must be separately operated.

Hinge derails are usually selected for service at storage, industrial or house tracks.

Use Hayes Model HB Series Derail with operating stands or when remote operation or electric interlocking is needed.

Ordering: Specify the size, and right or left hand. For EBX, specify size only.

Size: The size number is the distance in even inches from the top of the rail to the surface to which the derail is to be secured.

Any Hayes Derail may be used on rail 1/2 inch lower to 1/2 inch higher than the size number of the derail.

In every case the surface on which the derail is placed must be exactly even inches as stated on the nameplate, i.e. a size 6 must be 6 inches; adz or shim as necessary.

All sizes are priced the same.

*OPEN means derailing switch is open, thus diverting vehicle from the track.

WESTERN-CULLEN-HAYES, INC.

2700 W. 36th Place
(773) 254-9600

Chicago, Il. 60632
FAX (773) 254-1110



WESTERN-CULLEN-HAYES, INC.

120 N. 3rd Street, P.O. Box 756, Richmond, Indiana 47374
(765) 962-0526

FAX (765) 966-5374

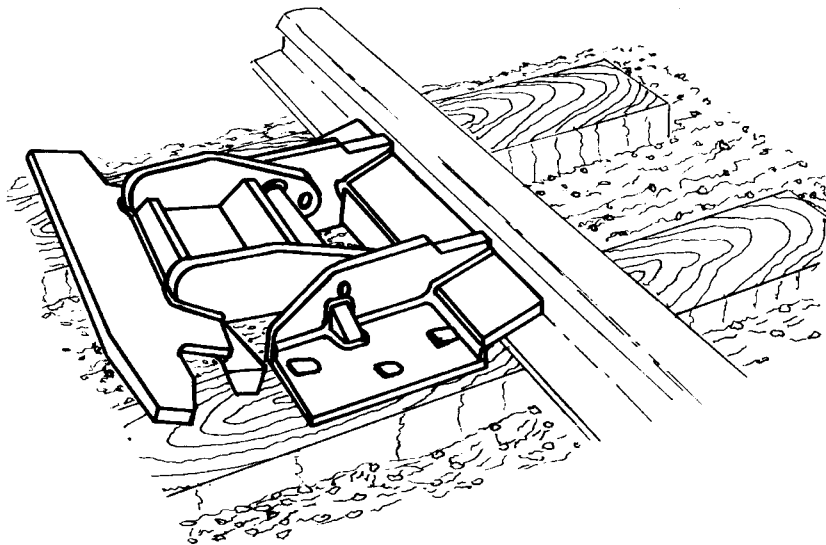

Model EB Right, Closed

Curves: Do not locate a derail on a curve where the wheels have a tendency to bind against the opposite rail. On curved track put the derail on the outside rail of the curve. Order a right hand or left hand accordingly.

Where difficult locations must be accommodated, we suggest the Hayes Derail Wheel Crowder be used.

Installation: Place the derail on two sound ties spaced to bear against the vertical flanges of the derail guide box. Again, refer to "Size" paragraph.

The derail block rests only against the top and gauge side of the rail. The block will drop flat onto the top of the rail if the derail is correctly placed.

Secure the derail in track with six spikes or heavy lag screws. Back up the derail plates with tie plates if there is doubt about the holding capacity of the ties.

The left lug of the derail is for the connecting rod of a Target Stand; the right lug is for locking the derail. When the derail has been correctly installed a padlock in this lug locks the derail block down close to the rail head.

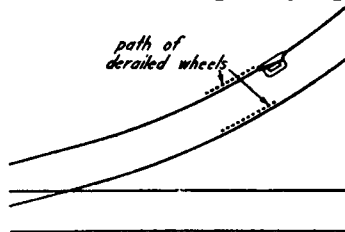

Incorrect Location of Derail on Curve

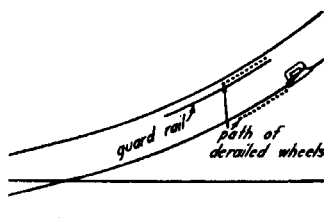

Correct Location of Derail on Curve

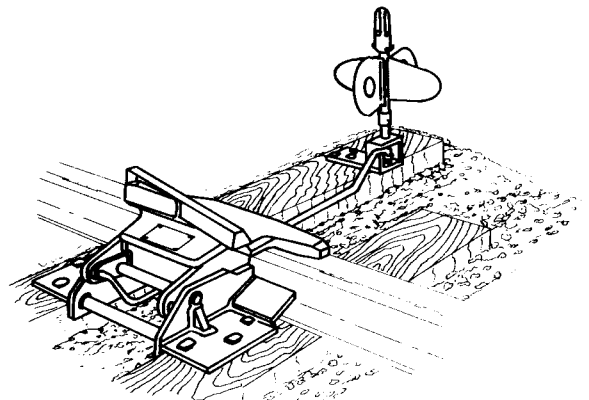

Model EB Right w/Target Stand

Fixed Blue Flag Derails Model EBF

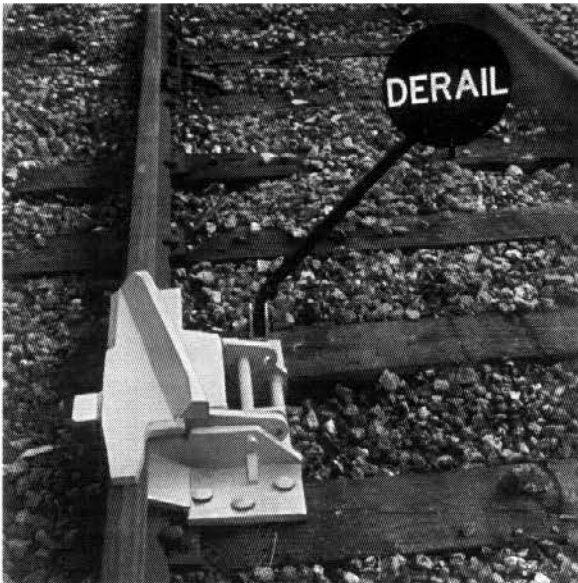

The Western-Cullen-Hayes Model EBF Derail incorporates the protection of a hinged type derail and the warning of a blue flag signal in one product. The Model EBF Derail spikes to the cross-ties in the same manner as our standard Model EB Derail, but the integral blue flag of the EBF ensures that a blue flag will always be readily available for that particular derail. The blue flag can be quickly applied and removed, and the derail can be padlocked in either the open or closed position.

EBF Derails are of all steel construction, are available in either right hand or left hand models in sizes 4 through 8 and weigh approximately 160 pounds. The standard blue flag message is "Derail", other messages are available on request.

Installation

Place the derail on two sound ties spaced to bear against the vertical flanges of the derail guide box. The surface on which the guide box is secured must be the same distance below the top of the rail as the size number of the guide box. With a size 6, for example, this must be 6 inches. Add shims or adz ties to achieve this exact distance. The derail block rests only against the top and gauge side of the rail. The block will drop flat onto the top of the rail, if the derail is correctly placed. Secure the derail in track with six spikes or heavy lag screws.

The left lug of the derail is for the connecting rod of a Target Stand. The hasp of a padlock will not fit this lug. The right lug is for locking the derail. When the derail has been correctly installed a padlock in this lug locks the derail block down close to the rail head.

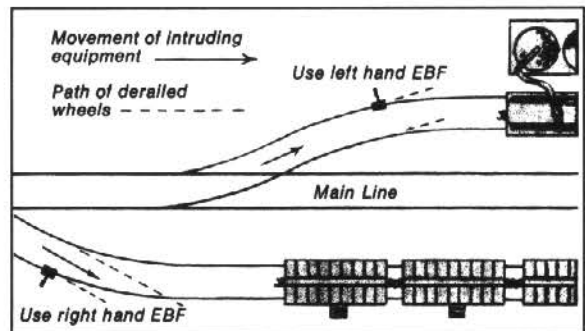

Curves: Do not locate a derail on a curve where the wheels have a tendency to bind against the opposite rail. On curved track put the derail on the outside rail of the curve, ordering a right or left accordingly.

Model SA-XS Hinged Type Derail

The new Model SA-XS* hinged derail is fabricated from steel, but is longer than the current EBX type derail. The longer design of the SA-XS provides a bi-directional derail with a deflection angle similar to our single direction derails. Deflection angle is critical to the effective function of any derail device.

We have added an assist spring and hand grip to the design of the SA-XS to significantly reduce the effort required to apply and remove the derail from the rail.

The Model SA-XS is manufactured in sizes to fit today's most popular rail sections. Please contact Western-Cullen-Hayes for more information on all of our derail products. Look to Western-Cullen-Hayes for the latest innovations in Derails, Derail Operators and Railroad Safety Equipment.

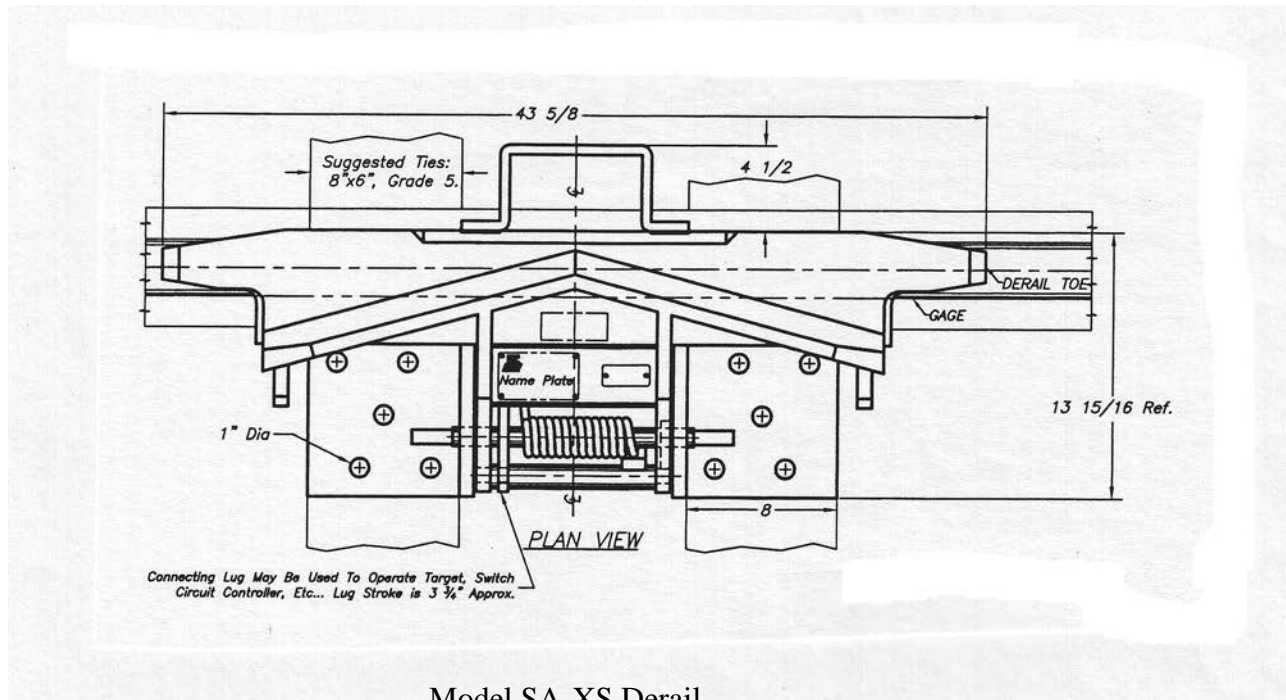

Model SA-XS Derail

*Patent Applied For

WESTERN-CULLEN-HAYES, INC.

120 N. 3rd. Street, P.O. Box 756 Richmond, Indiana 47374
(765) 962-0526

FAX (765) 966-5374

Proper Installation of a Hayes Hinged Type Derail

Site selection for Western-Cullen-Hayes hinged style derail is similar to that of our sliding derails. However, there is no need for long headblock ties. Model EB, SA and SA-XS derails can be installed on eight foot, six inch cross ties without any problem. These ties should be new, grade five, properly installed and ballasted for adequate drainage.

As with our sliding derails, hinged derails should never be installed on the inside, or lower rail of a curve. Derails should be placed far enough in front the area being protected to ensure the derailed rolling stock can safely come to a stop, before striking any structures or other equipment.

The size of the derail is determined by the total height of the rail and any tie plate derail location. If tie plates are used, they must be cropped off even with the foot of the rail on the gauge side of the track. It may be necessary to shim the derail up or to adz the cross ties down to ensure proper fit.

To install the derail, place it on the ties, in the gauge of the track. With the derail in the closed or "off rail" position, shove it against the base of the rail. Make sure the cross ties are parallel and the vertical flanges of the derail bear against both ties. Carefully rotate the derail to the open or "on rail" position. The derail shoe should overhang the top of the rail one half inch to the field side. If this is the case, the derail is ready to be fastened down. We recommend lag screws, in all available mounting holes, for securing the derail to the ties. The derail is now ready for service.

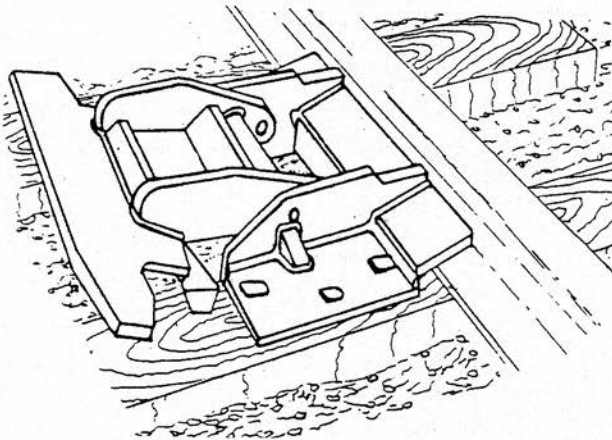

Hinged AType Derail Off Rail

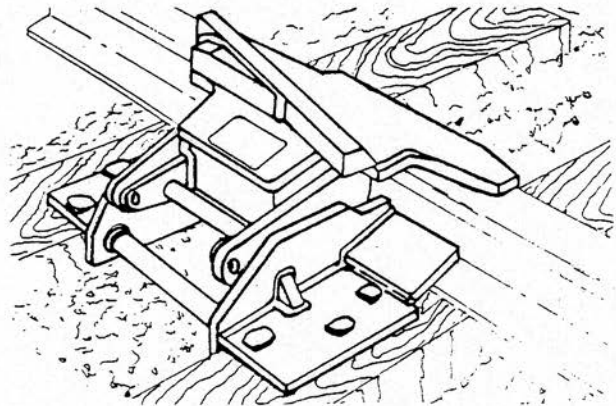

Hinged AType Derail On Rail

WESTERN-CULLEN-HAYES, INC.

120 N. 3rd. Street, P.O. Box 756 Richmond, Indiana 47374
(765) 962-0526

FAX (765) 966-5374

Spring Assisted Hinged Style Derails

Spring assisted, Model SA, hinged derails significantly reduce the lifting effort required to move the derail on or off the rail. These derails are fabricated from steel and are sized to ensure proper fit on today's most popular rail sections. Model SA derails come in left or right hand versions. We also make a two way SA, the SA-XS, that is larger than our traditional bi-directional, hinged derail. All of our hinged style derails incorporate a hand grip for ease of lifting. Installation requirements for the SA style derails are the same as all other Western-Cullen-Hayes derails.

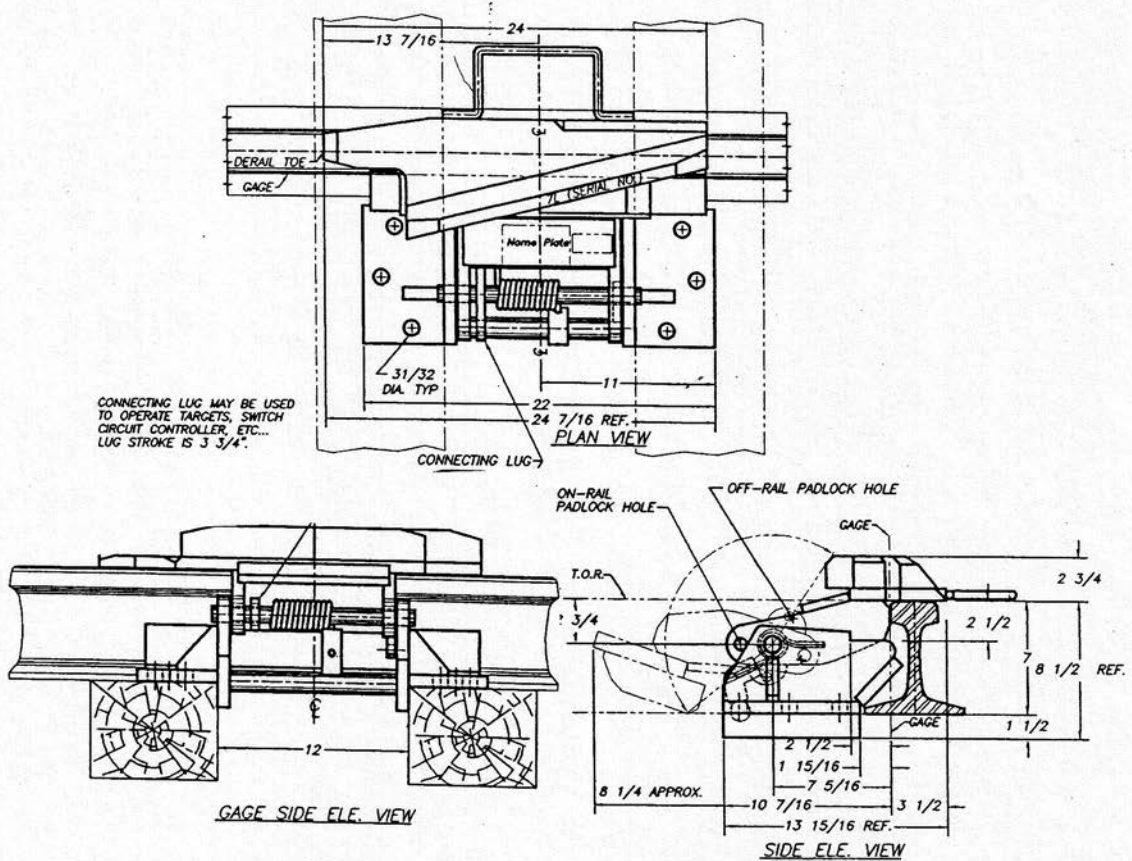

WESTERN-CULLEN-HAYES, INC.

120 N. 3rd. Street, P.O. Box 756 Richmond, Indiana 47374
 (765) 962-0526 FAX (765) 966-5374