

PART NO. L026495

LEGEND

1. ENGINE 16-710G3C-T2
2. GENERATOR/ALTERNATOR TA17-CA9
3. ENGINE AIR FILTER
4. ENGINE EXHAUST SILENCER
5. DUST BIN/LOCKER BLOWER MOTOR
6. INERTIAL FILTER AIR INLET
7. ELECTRICAL LOCKER
8. INVERTER/TRACTION MOTOR BLOWER
9. GENERATOR BLOWER MOTOR
10. GENERATOR PARTITION
11. ELECTRICAL LOCKER FILTERS
12. CREW CABINET
13. EQUIPMENT RACK
14. AIR COMPRESSOR (SHAFT DRIVEN)
15. #1 RESERVOIR (AUX-DECK MOUNTED)
16. #2 RESERVOIR (MICRO AIR BRAKE)
17. #3 RESERVOIR (AIR START)
18. FUEL TANK (5000 GAL)
19. ENGINE ROOM PARTITION
20. HANDBRAKE - RECESSED (WHEEL TYPE)
21. #2 TRACTION MOTOR BLOWER
22. DYNAMIC BRAKE GRIDS
23. 58 IN. COOLING FANS
24. RADIATOR
25. BOGIE (3 AXLE/3 MOTOR)
26. TRACTION MOTORS ITB2830A
27. WHEELS (43 IN. DIA.)
28. COUPLER (E-TYPE)
29. SANDBOX (30 CU FT-EACH END)
30. SANDBOX CLEANOUTS
31. SNOWPLOW
32. HORN
33. BATTERIES
34. REMOVABLE DUST BIN/LOCKER BLOWER COVER
35. REMOVABLE SILENCER & TURBO HATCH
36. REMOVABLE ENGINE HOOD SECTION
37. REMOVABLE GENERATOR COMPARTMENT SECTION
38. REMOVABLE FAN HATCH
39. REMOVABLE DYNAMIC BRAKE HATCH
40. DYNAMIC BRAKE GRID ACCESS
41. ENGINE ACCESS DOORS
42. GENERATOR ACCESS DOORS
43. INVERTER/TRACTION MOTOR ACCESS COVER
44. DYNAMIC BRAKE AIR INLET
45. JACKING PADS
46. DRAFT GEAR (NC390)
47. SANDBOX FILLER
48. SIDE STEPS
49. SAND TRAP ACCESS
50. ENGINE HOOD SLIP JOINT

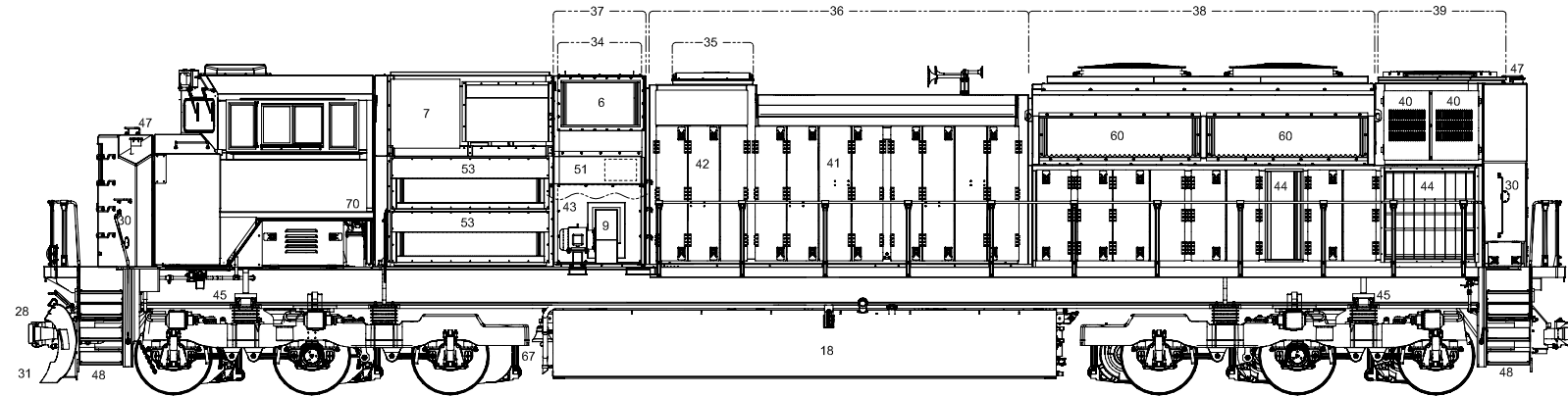
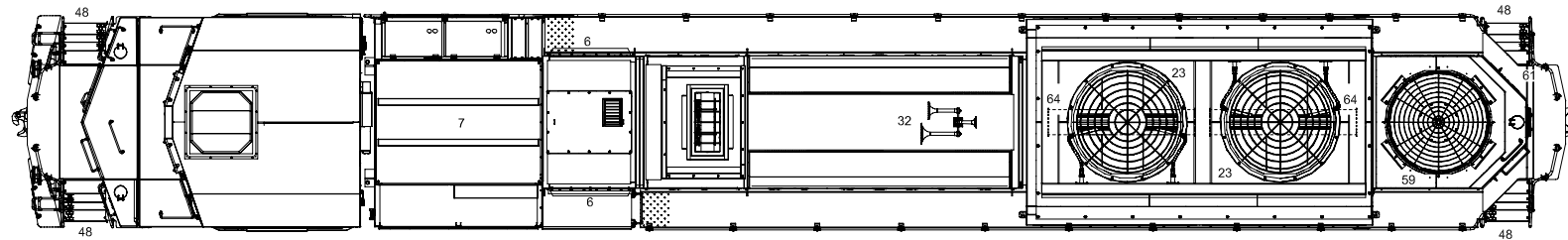
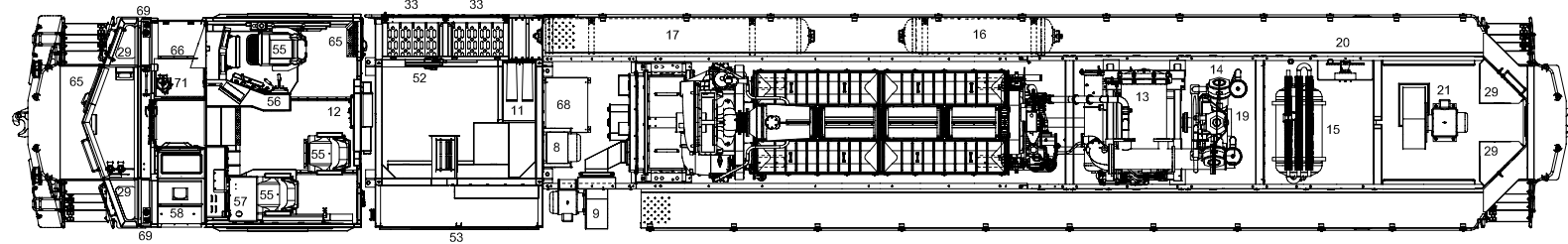

LEGEND

51. REMOVABLE WALKWAY/LADDER SECTION
52. ELECTRICAL LOCKER ACCESS DOOR
53. INVERTER ACCESS DOORS
54. LUBE OIL STRAINER
55. CAB SEAT
56. ENGINEERS WORKSTATION
57. HELPERS WORKSTATION
58. TOILET COMPARTMENT
59. DYNAMIC BRAKE GUARD
60. COOLING AIR INLET
61. ROOF ACCESS
62. NUMBER BOXES
63. HEADLIGHT
64. WATER TANK (CARBODY MOUNTED)
65. CAB ACCESS DOORS
66. CAB ELECTRONICS
67. BELL
68. GENERATOR COMPARTMENT WALKWAY
69. CAB FRONT ISOLATOR
70. CAB REAR ISOLATOR
71. FIRE EXTINGUISHER

NOTE:
 LOCOMOTIVE HEIGHT TOLERANCE IS @ 1.50 IN.
 LOCOMOTIVE WIDTH TOLERANCE IS @ .50 IN.
 TRUCK LATERAL (BOLSTERS & JOURNALS TOLERANCE WITH NEW TRUCKS IS @ 2.25 IN.
 LOCOMOTIVE IS SHOWN IN A NOMINAL STATE INCLUDING HALF VARIABLE SUPPLIES, IN A NEW CONDITION AND STANDING STILL ON LEVEL AND TANGENT TRACK.

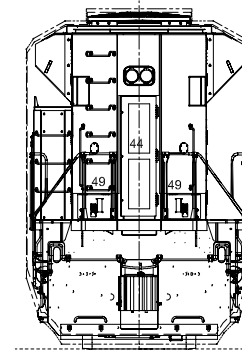
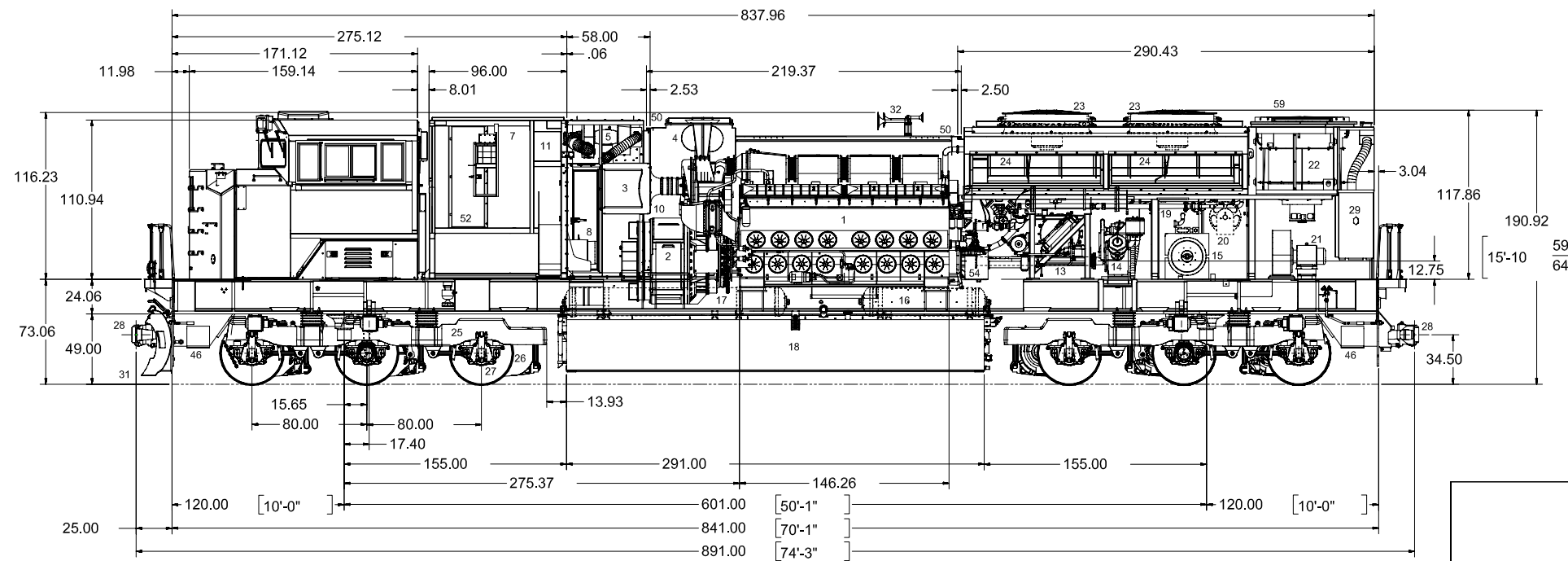
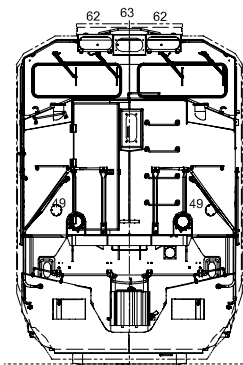

NOTE; GEOMETRY IS FOR REFERENCE ONLY

REV		REVISION	DATE	BY	APVD		
						RAJ MULLIGU (S-M) 200 L026495 L026495 SB70ACE L026495 SHEET 1 OF 1	
						36 FORMAT UG SOLID	