



CONTINENTAL MOTORS
A Teledyne Technologies Company

Permold Series Overhaul Manual

MODELS IO-550-A

**B
C
G
N
P
R**

FUEL NOZZLES

1. The fuel nozzles must be overhauled in accordance with TCM Fuel Injection Systems Overhaul Manual and Parts Catalog, Form X30593A or replaced with a serviceable unit. See section 1-5, "Related Publications," for ordering information. Teledyne Continental Motors offers factory rebuilt fuel injection system components at exchange prices as an alternative to field overhaul of these units.

NOTE...Further disassembly of the fuel injection system components is not advised unless the proper flow test equipment is available.

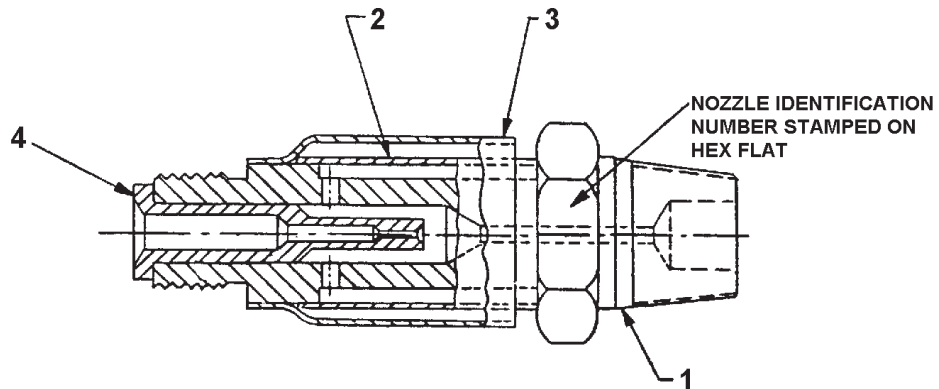

FIGURE 9-6A. FUEL NOZZLE I0-550-A, B & C

- | | |
|-----------|-----------|
| 1. Nozzle | 3. Shield |
| 2. Screen | 4. Jet |

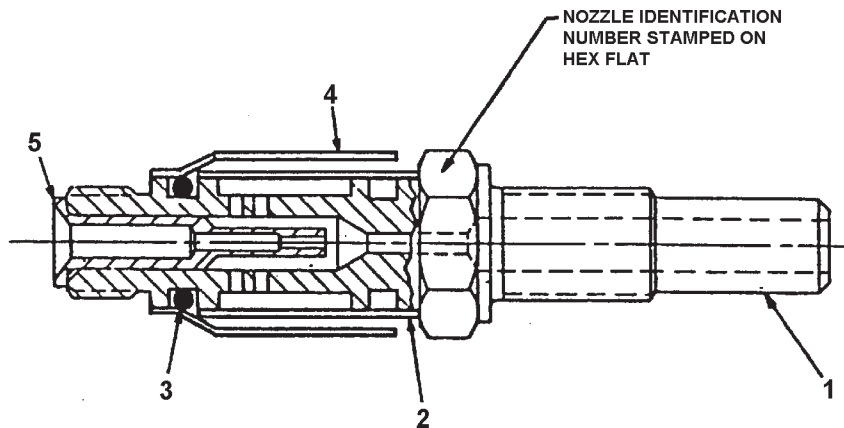

FIGURE 9-6B. FUEL NOZZLE I0-550-G, N, P & R

- | | | |
|-----------|-----------|--------|
| 1. Nozzle | 3. O-Ring | 5. Jet |
| 2. Screen | 4. Shield | |