



ATTACHMENT 2

AIRWORTHINESS GROUP CHAIRMAN'S FACTUAL REPORT

NTSB No. CEN15MA290

Airbus Helicopters Service Bulletin No. AS350-67.00.64 (63 Pages)

Civil versions: B3

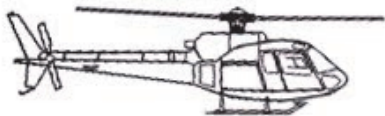

SERVICE BULLETIN

SUBJECT: ROTOR FLIGHT CONTROLS - Double hydraulic servocontrols

"HYDR" test indication for double hydraulic servocontrols
 Corresponds to modification 074622

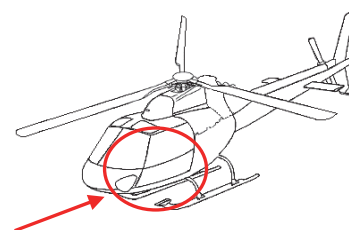
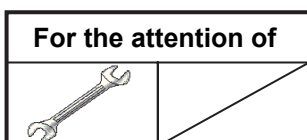

Revision No.	Date of issue
Revision 0	2015-02-25

Summary:

Modify the "HYDR" test indication on helicopters equipped with the double hydraulic system by:

- Indicating to the pilot that the hydraulic switch on the collective grip is set to "OFF".
- Adding a second indicator light on the caution and warning panel to indicate the status of the two systems.

Compliance:

Airbus Helicopters recommends compliance with this Service Bulletin.

1. PLANNING INFORMATION

1.A. EFFECTIVITY

1.A.1. Helicopters/Installed equipment

Helicopters equipped with the double hydraulic servocontrol and which are PRE MOD 074622.

NOTE

Refer to the Individual Inspection Record (RIC-AMS) to identify the actual modification status of the aircraft.

1.A.2. Non-installed equipment

Not applicable.

1.B. ASSOCIATED REQUIREMENTS

Not applicable.

1.C. REASON

The purpose of modification 074622 is to:

- Indicate to the pilot that the hydraulic switch on the collective grip is set to "OFF" by a flashing of the "HYD2" indicator light on the caution and warning panel.
- Allow the pilot to check that the pressure switch associated with each hydraulic system is functional before take-off.

1.D. DESCRIPTION

Modification 074622 consists in installing a timer relay and adding a second "HYD2" indicator light on the caution and warning panel.

1.E. COMPLIANCE
1.E.1. Compliance at the works

Not applicable.

1.E.2. Compliance in service

The user must carry out the work on the helicopter.

Helicopters/installed equipment:

As per the table below, comply with the paragraphs of this Service Bulletin Revision 0 during a future maintenance inspection in accordance with the operator's operational availability.

Configurations	Paragraph to be complied with	Kits and items to be ordered
POST MOD 073450 and PRE MOD 075601	- 3.B.2.a. - 3.B.2.b.1. - 3.B.2.c.1.	350A07-4622-0071 350A61-2645-44 704A47-7230-58
POST MOD 075601 and PRE MOD 074280	- 3.B.2.a. - 3.B.2.b.2. - 3.B.2.c.1.	350A07-4622-0071 350A61-2645-44 704A47-7230-58
POST MOD 074280 and PRE MOD 075606	- 3.B.2.a. - 3.B.2.b.3. - 3.B.2.c.2.	350A07-4622-0071 350A61-2645-45
POST MOD 075606	- 3.B.2.a. - 3.B.2.b.4. - 3.B.2.c.2.	350A07-4622-0071 350A61-2645-45
POST OP 3346 and PRE MOD 073368	- 3.B.2.a. - 3.B.2.b.5. - 3.B.2.c.2.	350A07-4622-0171 350A61-2645-42
POST MOD 073368 and POST MOD 073391 and PRE MOD 073450	- 3.B.2.a. - 3.B.2.b.6. - 3.B.2.c.1.	350A07-4622-0171 350A61-2645-44 704A47-7230-58

In addition, for helicopters with Automatic Pilot (A.P.) fixed parts:

Configurations	Paragraph to be complied with	Kits and items to be ordered
Automatic Pilot (A.P.) fixed parts	- 3.B.2.b.7. - 3.B.2.c.2.	350A61-2645-49

Description of modifications listed above:

- OP 3346: Dual hydraulic installation.
- 073368: Instrument panel standardization.
- 073391: Replacement of AUXITROL pressure switches by Industria pressure switches.
- 073450: Modifications of sticks.
- 074280: Change the Systems Control Unit SMS by a multi Bloc Logical
- 075601: Additional chin weights on tail rotor, reinforced control rod, suppression of compensator lever on yaw channel, reinforced pitch lever and elastomer pitch.
- 075606: Removal of additional Chin weights on tail rotor and addition of compensator lever on yaw channel.

Non-installed equipment:

Not applicable.

1.F. APPROVAL

Approval of modifications:

The information or instructions relate to modification 074622 which was approved on December 03, 2014 under the authority of EASA Design Organization Approval No. 21J.056 for helicopters of civil versions subject to an Airworthiness Certificate.

Approval of this document:



The technical information contained in this Service Bulletin Revision 0 was approved on January 06, 2015 under the authority of EASA Design Organization Approval No. 21J.056 for helicopters of civil versions subject to an Airworthiness Certificate.

1.G. MANPOWER

For compliance with this Service Bulletin, Airbus Helicopters recommends the following personnel qualifications:

Qualification: 1 Avionics Technician.
1 Airframe Technician.



Time for the operations:

Times for the operations are indicated for reference, for a standard configuration.

Time for the operations: 1 hour approximately for the Airframe Technician.
8 hours approximately for the Avionics Technician.



Estimated helicopter grounding time:

The estimated helicopter downtime is approximately 1 day.

1.H. WEIGHT AND BALANCE

Not applicable.

1.I. EFFECT ON ELECTRICAL LOADS

Not applicable.

1.J. SOFTWARE MODIFICATION EMBODIMENT RECORD

Not applicable.

1.K. REFERENCES

The following documents are required for compliance with this Service Bulletin:

Standard Practices Manual (MTC):

- MTC: 20.02.01.415: Installation of electrical cable bundles and optical fibers
- MTC: 20.02.01.418: Protection of electrical wiring during maintenance operations
- MTC: 20.02.04.401: Installation of rivets - pitch and edge distance
- MTC: 20.02.04.601: General riveting acceptance requirements
- MTC: 20.02.05.404: Joining by bolts and nuts
- MTC: 20.02.07.101: Electrical bonding - General
- MTC: 20.02.07.401: Bonding procedure
- MTC: 20.07.01.201: Handling of helicopters in a hangar and in a prepared area
- MTC: 20.07.03.406: Instructions applicable when working on an aircraft electrical circuit and power generating systems
- MTC: 20.07.03.408: Appearance checks on an aircraft after an inspection or repair
- MTC: 20.80.20.101: Contact insertion and extraction method and tools
- MTC: 20.80.20.401: Crimping splices on unshielded cables
- MTC: 20.80.20.402: Removal/installation of cable ties
- MTC: 20.80.20.407: Tools and processes for stripping cables
- MTC: 20.80.20.413: Installing relays and junction modules
- MTC: 20.80.20.425: Tools and settings associated with the crimping of contacts
- MTC: 20.80.20.433: Crimping splices on non-shielded cables (procedure)
- MTC: 20.80.20.603: Securing rules for electrical harnesses

Aircraft Maintenance Manual (AMM):

- AMM: 24-00-00, 3-1: Electrical power system - General instructions
- AMM: 29-00-00, 3-1: Hydraulic power system - General instructions

1.L. DOCUMENTS AFFECTED



The modification will be integrated in the following manuals:

- Illustrated Parts Catalog (IPC).
- Aircraft Maintenance Manual (AMM).
- Wiring Diagram Manual (WDM).
- Flight Manual (FLM).

Document updates must be ordered by the customer.

1.M. INTERCHANGEABILITY OR MIXABILITY OF PARTS

Interchangeability:

Not applicable.

Mixability:

Not applicable.

2. MATERIAL INFORMATION

2.A. MATERIAL: PRICE - AVAILABILITY - PROCUREMENT

For any information concerning components, contact the Airbus Helicopters network's Customer Support Sales Department.

Order the components in accordance with the configuration (refer to paragraph 1.E.2.) at the following address:

Airbus Helicopters
 Etablissement de Marignane
 Direction Ventes et Relations Client
 13725 MARGNANE CEDEX
 France

NOTE

On the purchase order, please specify the mode of transport, the destination and the serial numbers of the aircraft to be modified.

A limited quantity of kits is available on the day this Service Bulletin is issued. Operators affected by compliance with this Service Bulletin are requested to quickly inform Airbus Helicopters in order to remedy any possible stock out.

Stock state at the time of issue of this Service Bulletin and provisional procurement schedule:

KIT P/N	KEY WORD	STOCK	AVAILABILITY		
			20 Kits		
350A0746220071	Relay 54D installation adaptation	2	W25-2015		
350A0746220171	Relay 54D installation adaptation With PCB (CI)	10	W25-2015		
			AVAILABILITY		
			2 Parts	10 Parts	40 Parts
704A47723058	Warning panel	4		W23-2015	W31-2015
350A61264542	Label WP ENG	20	/	/	/
350A61264544	Label WP ENG Label WP ENG	0	/	/	W14-2015
350A61264545	Label WP ENG	0	W09-2015	/	/
350A61264549	Label WP 3B with AP	5	/	/	/

W=Week

2.B. INFORMATION CONCERNING INDUSTRIAL SUPPORT

Not applicable.

2.C. MATERIAL REQUIRED FOR EACH HELICOPTER/COMPONENT

Kits or components to be ordered for one helicopter or one assembly:

Key Word	Qty	New P/N	Item	Former P/N	Instruction
<u>Adaptation of relay 54D installation without PCB (CI) and without AP:</u>	1	<u>350A07-4622-0071</u>			
Set, wires and markers	1	350A08-4605-0098	1		
Relay, timer	1	706A36-521-010	2		
Base, relay	1	M12883/40-23	3		
Contact, swaged	4	EN3155-017F1620	4		
Module	1	EN4165A20-221CB	5		
Adapter	1	EN4165C13A4	7		
Contact, swaged	3	EN3155-016M2018	8		
Extension	1	E0541-11	9		
Contact, swaged	8	EN3155-003F2222	10		
Contact, swaged	4	EN3155-019F2020	11		
Contact, ground	2	130743-1	12		
Rivet	4	21215DC3207J	13		
Support, 4RT5A relay	1	350A61-2988-20	14		
Screw	4	22273CE040016	15		
Extension	1	ECS0739A20-20	19		

Key Word	Qty	New P/N	Item	Former P/N	Instruction
<u>Adaptation of relay 54D installation with PCB (CI) and without AP:</u>	1	<u>350A07-4622-0171</u>			
Relay, timer	1	706A36-521-010	2		
Base, relay	1	M12883/40-23	3		
Contact, swaged	4	EN3155-017F1620	4		
Contact, swaged	3	EN3155-016M2018	8		
Extension	1	E0541-11	9		
Contact, swaged	4	EN3155-003F2222	10		
Contact, swaged	4	EN3155-019F2020	11		
Contact, ground	2	130743-1	12		
Rivet	4	21215DC3207J	13		
Support, 4RT5A relay	1	350A61-2988-20	14		
Screw	4	22273CE040016	15		
Set, wires and markers	1	350A08-4606-0098	17		
Contact, PCB (CI)	2	770522-1	18		
Extension	1	ECS0739A20-20	19		

Material to be ordered separately:

Key Word	Qty	New P/N	Item	Former P/N	Instruction
Clamp, binding	50	E0043-4D11P	31		
Clamp, binding	50	E0043-5D11P	32		
Wire, electrical	2 m	EN2267-010A004S	33		

For helicopters POST MOD 074300 or POST MOD 073450 or POST MOD 073475 or POST MOD 073368

Key Word	Qty	New P/N	Item	Former P/N	Instruction
Label	1	350A61-2645-44	40	350A61-2645-29	To be retained
Caution and warning panel	1	704A47-7230-58	41	704A47-7230-72	To be retained

For helicopters POST MOD 074280 or POST MOD 074664

Key Word	Qty	New P/N	Item	Former P/N	Instruction
Label	1	350A61-2645-45	42	350A61-2645-37	To be retained

For helicopters PRE MOD 073368 and PRE MOD 074300

Key Word	Qty	New P/N	Item	Former P/N	Instruction
Label	1	350A61-2645-42	43	350A61-2645-25	To be retained

For helicopters with A.P. fixed parts

Key Word	Qty	New P/N	Item	Former P/N	Instruction
Label	1	350A61-2645-49	44	350A61-2645-34	To be retained

Products to be ordered separately:

As per Work Cards and/or Tasks mentioned in this Service Bulletin.

The products may be ordered separately from INTERTURBINE AVIATION LOGISTICS.

Website: <http://www.interturbine.com>

Telephone: +49.41.91.809.300

AOG: +49.41.91.809.444

Material required for non-installed components:

Not applicable.

2.D. MATERIAL TO BE RETURNED

Not applicable.

3. ACCOMPLISHMENT INSTRUCTIONS

3.A. GENERAL

- Read and comply with the general instructions for the installation of electrical cable bundles and optical fibers as per MTC Work Card 20.02.01.415.
- Read and comply with the general instructions for the protection of electrical wiring during maintenance operations as per MTC Work Card 20.02.01.418.
- Read and comply with the instructions for the installation of rivets and the general riveting acceptance requirements as per MTC Work Cards 20.02.04.401 and 20.02.04.601.
- Read and comply with the instructions for joining by bolts and nuts as per MTC Work Card 20.02.05.404.
- Read and comply with the general instructions for the electrical bonding and bonding procedure as per MTC Work Cards 20.02.07.101 and 20.02.07.401.
- Read and comply with the instructions for handling of helicopters in a hangar and in a prepared area as per MTC Work Card 20.07.01.201.
- Read and comply with the instructions for contact insertion and extraction method and tools as per MTC Work Card 20.80.20.101.
- Read and comply with the instructions for crimping splices on unshielded cables as per MTC Work Cards 20.80.20.401 and 20.80.20.433.
- Read and comply with the instructions for the removal and installation of cable ties as per MTC Work Card 20.80.20.402.
- Read and comply with the instructions on tools and processes for stripping cables as per MTC Work Card 20.80.20.407.
- Read and comply with the instructions for installation of relays and junction modules as per MTC Work Card 20.80.20.413.
- Read and comply with the instructions on tools and settings associated with the crimping of contacts as per MTC Work Card 20.80.20.425.
- Read and comply with the securing rules for electrical harnesses as per MTC Work Card 20.80.20.603.
- Read and comply with the general instructions for the electrical power system as per AMM Task 24-00-00, 3-1.
- Read and comply with the general instructions for the hydraulic power system as per AMM Task 29-00-00, 3-1.

3.B. OPERATIONAL PROCEDURE

3.B.1. Preliminary steps

- Implement suitable access means.
- Disconnect all electrical power supply sources as per MTC Work Card 20.07.03.406.
- Open the required cowlings.

3.B.2. Procedure

3.B.2.a Installation of relay support 54D

- Drill back the floor to match relay support (14) as per Detail D, Figure 1.
- Clean, deburr and electrically bond.
- Attach relay support (14) with rivets (13) as per Detail D, Figure 1.
- Bond label "54D" from set of wires and markers (1) or (17) as close as possible.

3.B.2.b. Modification of the wiring

3.B.2.b.1. For helicopters POST MOD 073450 and PRE MOD 075601 (Figures 1, 2, 4, 5, 12 and 13)

- Cut and discard the binding clamps (not shown on Figures) that hold the electrical harnesses.
- Install base (3) on relay support (14) (Figure 1) with its bolts and nuts.
- Route the wiring using sets of wires and markers (1) and (33) and wire to contacts (4), (8), (10) and (11), ground contacts (12) (refer to appendix 4.A.), extensions (9) and (19), module (5) and its adapter (7), as per Figures 2, 4, 5, 12 and 13.
- Carry out a continuity test of the modified wiring.
- Install timer relay (2) on base (3).
- Attach the electrical harnesses with binding clamps (31) or (32) (not shown on Figures).

3.B.2.b.2. For helicopters POST MOD 075601 and PRE MOD 074280 (Figures 1, 2, 6, 7, 12 and 13)

- Cut and discard the binding clamps (not shown on Figures) that hold the electrical harnesses.
- Install base (3) on relay support (14) (Figure 1) with its bolts and nuts.
- Route the wiring using sets of wires and markers (1) and (33) and wire to contacts (4), (8), (10) and (11), ground contacts (12) (refer to appendix 4.A.), extensions (9) and (19), module (5) and its adapter (7), as per Figures 2, 6, 7, 12 and 13.
- Carry out a continuity test of the modified wiring.
- Install timer relay (2) on base (3).
- Attach the electrical harnesses with binding clamps (31) or (32) (not shown on Figures).

3.B.2.b.3. For helicopters POST MOD 074280 and PRE MOD 075606 (Figures 1, 3, 8 and 9)

- Cut and discard the binding clamps (not shown on Figures) that hold the electrical harnesses.
- Install base (3) on relay support (14) (Figure 1) with its bolts and nuts.
- Route the wiring using sets of wires and markers (1) and (33) and wire to contacts (4), (8), (10) and (11), ground contacts (12) (refer to appendix 4.A.), extensions (9) and (19), module (5) and its adapter (7), as per Figures 3, 8 and 9.
- Carry out a continuity test of the modified wiring.
- Install timer relay (2) on base (3).
- Attach the electrical harnesses with binding clamps (31) or (32) (not shown on Figures).

3.B.2.b.4. For helicopters POST MOD 075606 (Figures 1, 3, 10 and 11)

- Cut and discard the binding clamps (not shown on Figures) that hold the electrical harnesses.
- Install base (3) on relay support (14) (Figure 1) with its bolts and nuts.
- Route the wiring using sets of wires and markers (1) and (33) and wire to contacts (4), (8), (10) and (11), ground contacts (12) (refer to appendix 4.A.), extensions (9) and (19), module (5) and its adapter (7), as per Figures 3, 10 and 11.
- Carry out a continuity test of the modified wiring.
- Install timer relay (2) on base (3).
- Attach the electrical harnesses with binding clamps (31) or (32) (not shown on Figures).

3.B.2.b.5. For helicopters POST OP 3346 and PRE MOD 073368 (Figures 1, 14, 15 and 16)

- Cut and discard the binding clamps (not shown on Figures) that hold the electrical harnesses.
- Install base (3) on relay support (14) (Figure 1) with its bolts and nuts.
- Route the wiring using sets of wires and markers (17) and wire to contacts (4), (8), (10) and (11), ground contacts (12) (refer to appendix 4.A.), PCB (CI) contacts (18) (refer to appendix 4.B.) and extensions (9) and (19) as per Figures 14, 15 and 16.
- Carry out a continuity test of the modified wiring.
- Install timer relay (2) on base (3).
- Attach the electrical harnesses with binding clamps (31) or (32) (not shown on Figures).

3.B.2.b.6. For helicopters POST MOD 073368 and POST MOD 073391 and PRE MOD 073450
(Figures 1, 15, 16, 17, 18 and 19)

- Cut and discard the binding clamps (not shown on Figures) that hold the electrical harnesses.
- Install base (3) on relay support (14) (Figure 1) with its nuts and bolts.
- Route the wiring using sets of wires and markers (17) and wire to contacts (4), (8), (10) and (11), ground contacts (12) (refer to appendix 4.A.), PCB (CI) contacts (18) (refer to appendix 4.B.) and extensions (9) and (19) as per Figures 15, 16, 17, 18 and 19.
- Carry out a continuity test of the modified wiring.
- Install timer relay (2) on base (3).
- Attach the electrical harnesses with binding clamps (31) or (32) (not shown on Figures).

3.B.2.b.7. For helicopters with A.P. fixed parts (Figure 20)

- Modify wiring as per Figure 20.
- Carry out a continuity test of the modified wiring.

3.B.2.c. Modification of caution and warning panel

3.B.2.c.1. For helicopters POST MOD 073450 and PRE MOD 075601 or POST MOD 075601 and PRE MOD 074280 or POST MOD 073368 and POST MOD 073391 and PRE MOD 073450 (Figure 21)

- Remove caution and warning panel assembly (a) and discard screws (b).
- Perform electrical bonding of screws (15).
- Attach new caution and warning panel (41) with screws (15).
- Tighten screws (15) to standard torque.
- Remove label (c):
 - . remove and retain screws (d),
 - . remove and retain front face (e),
 - . remove and discard label (c).
- Install label (40):
 - . install label (40) between caution and warning panel (41) and front face (e),
 - . attach front face (e) to caution and warning panel (41) with screws (d).

3.B.2.c.2. For helicopters POST MOD 074280 and PRE MOD 075606 or POST MOD 075606 or POST OP 3346 and PRE MOD 073368 or with A.P. fixed parts (Figure 21)

- Remove label (c):
 - . remove and retain screws (d),
 - . remove and retain front face (e),
 - . remove and discard label (c).
- Install label (42) or (43) or (44):
 - . install label (42) or (43) or (44) between caution and warning panel (a) and front face (e),
 - . attach front face (e) to caution and warning panel (a) with screws (d).

PAGE LEFT BLANK INTENTIONALLY

3.B.3. Tests
3.B.3.a For helicopters PRE MOD 074280

Carry out the tests as per the table below:

	ACTION	CHECK	COMMENTS
1	- Set the "HYD" switch to the "ON" position. - Set the "BAT/EPU" switch to the "ON" position.	- The "SERVO", "HYD1" and "HYD2" indicator lights on the caution and warning panel are steadily lit.	
2	- Press the "SERVO TST" pushbutton on panel "30α".	- The "SERVO" indicator light on the caution and warning panel goes out.	
3	- Release the "SERVO TST" pushbutton.	- The "SERVO" indicator light on the caution and warning panel comes on.	
4	- Disconnect RH servocontrol (1D3).	- The "LIMIT" indicator light on the caution and warning panel of the instrument panel comes on.	
5	- Reconnect RH servocontrol (1D3). - Disconnect hydraulic pressure switch 3D2.	- The "LIMIT" indicator light on the caution and warning panel of the instrument panel goes out. - The "HYD2" indicator light on the failure-warning panel goes out. - The "HYD1" indicator light on the failure-warning panel stays on.	
6	- Disconnect hydraulic pressure switch 3D1.	- The "HYD1" indicator light on the failure-warning panel goes out.	
7	- Reconnect hydraulic pressure switch 3D2.	- The "HYD2" indicator light on the failure-warning panel comes on steady. - The "HYD1" indicator light on the failure-warning panel stays off.	
8	- Reconnect hydraulic pressure switch 3D1.	- The "HYD1" indicator light on the failure-warning panel comes on. - The "HYD2" indicator light on the failure-warning panel stays on.	
9	- Pressurize the system using the hydraulic benches. - Set the "HYD" switch on the collective stick to OFF.	- The "HYD1" indicator light on the caution and warning panel is off. - The "HYD2" indicator light on the caution and warning panel flashes (lit approximately 5 secs and off 1/2 sec). - Check that the solenoid valve (2D) is magnetized using a metal part.	
10	- Remove the "HYD" fuse (2.5 A) on panel 31α32.	- The "HYD2" indicator light on the caution and warning panel is steadily lit. - The solenoid valve is no longer magnetized.	
11	- Re-install the "HYD" fuse (2.5 A) on panel 31α32.	- The "HYD2" indicator light on the caution and warning panel flashes (lit approximately 5 secs and off 1/2 sec). - The solenoid valve is magnetized again.	
12	- Set the "HYD" switch on the collective stick to "ON".	- The solenoid valve is no longer magnetized.	
13	- Restore the helicopter to its initial configuration.	/	

PAGE LEFT BLANK INTENTIONALLY

3.B.3.b For helicopters POST MOD 074280

Carry out the tests as per the table below:

	ACTION	CHECK	COMMENTS
1	<ul style="list-style-type: none"> - Set the "HYD" switch to the "ON" position. - Set the "BAT" switch to the "ON" position. 	<ul style="list-style-type: none"> - The "SERVO", "HYD1" and "HYD2" indicator lights on the caution and warning panel are steadily lit. 	
2	<ul style="list-style-type: none"> - Press the "SERVO TST" pushbutton on panel "134α". 	<ul style="list-style-type: none"> - The "SERVO" indicator light on the caution and warning panel goes out. 	
3	<ul style="list-style-type: none"> - Release the "SERVO TST" pushbutton. 	<ul style="list-style-type: none"> - The "SERVO" indicator light on the caution and warning panel comes on. 	
4	<ul style="list-style-type: none"> - Disconnect RH servocontrol (1D3). 	<ul style="list-style-type: none"> - The "LIMIT" indicator light on the caution and warning panel of the instrument panel comes on. 	
5	<ul style="list-style-type: none"> - Reconnect RH servocontrol (1D3). - Disconnect hydraulic pressure switch 3D2. 	<ul style="list-style-type: none"> - The "LIMIT" indicator light on the caution and warning panel goes out. - The "HYD2" indicator light on the failure-warning panel goes out. - The "HYD1" indicator light on the failure-warning panel stays on. 	
6	<ul style="list-style-type: none"> - Disconnect hydraulic pressure switch 3D1. 	<ul style="list-style-type: none"> - The "HYD1" indicator light on the failure-warning panel goes out. 	
7	<ul style="list-style-type: none"> - Reconnect hydraulic pressure switch 3D2. 	<ul style="list-style-type: none"> - The "HYD2" indicator light on the failure-warning panel comes on steady. - The "HYD1" indicator light on the failure-warning panel stays off. 	
8	<ul style="list-style-type: none"> - Reconnect hydraulic pressure switch 3D1. 	<ul style="list-style-type: none"> - The "HYD1" indicator light on the failure-warning panel comes on. - The "HYD2" indicator light on the failure-warning panel stays on. 	
9	<ul style="list-style-type: none"> - Pressurize the system using the hydraulic benches. - Set the "HYD" switch on the collective stick to OFF. 	<ul style="list-style-type: none"> - The "HYD1" indicator light on the caution and warning panel is off. - The "HYD2" indicator light on the caution and warning panel flashes (lit approximately 5 secs and off 1/2 sec). - Check that the solenoid valve (2D) is magnetized using a metal part. 	
10	<ul style="list-style-type: none"> - Remove the "HYD" fuse (2.5 A) on panel 31α32. 	<ul style="list-style-type: none"> - The "HYD2" indicator light on the caution and warning panel is steadily lit. - The solenoid valve is no longer magnetized. 	
11	<ul style="list-style-type: none"> - Re-install the "HYD" fuse (2.5 A) on panel 31α32. 	<ul style="list-style-type: none"> - The "HYD2" indicator light on the caution and warning panel flashes (lit approximately 5 secs and off 1/2 sec). - The solenoid valve is magnetized again. 	
12	<ul style="list-style-type: none"> - Set the "HYD" switch on the collective stick to "ON". 	<ul style="list-style-type: none"> - The solenoid valve is no longer magnetized. 	
13	<ul style="list-style-type: none"> - Restore the helicopter to its initial configuration. 	/	

PAGE LEFT BLANK INTENTIONALLY

3.B.4. Final steps

- Close the cowlings.
- Carry out appearance checks on an aircraft after an inspection or repair as per MTC Work Card 20.07.03.408.
- Connect all electrical power supplies.
- Remove access means.

3.C. IDENTIFICATION

Identification of this document:

Record compliance with this Service Bulletin revision 0 in the aircraft documents.

Identification of modifications in the documents:

Record compliance with MOD 074622 in the aircraft documents.

3.D. OPERATING AND MAINTENANCE INSTRUCTIONS

Not applicable.

PAGE LEFT BLANK INTENTIONALLY

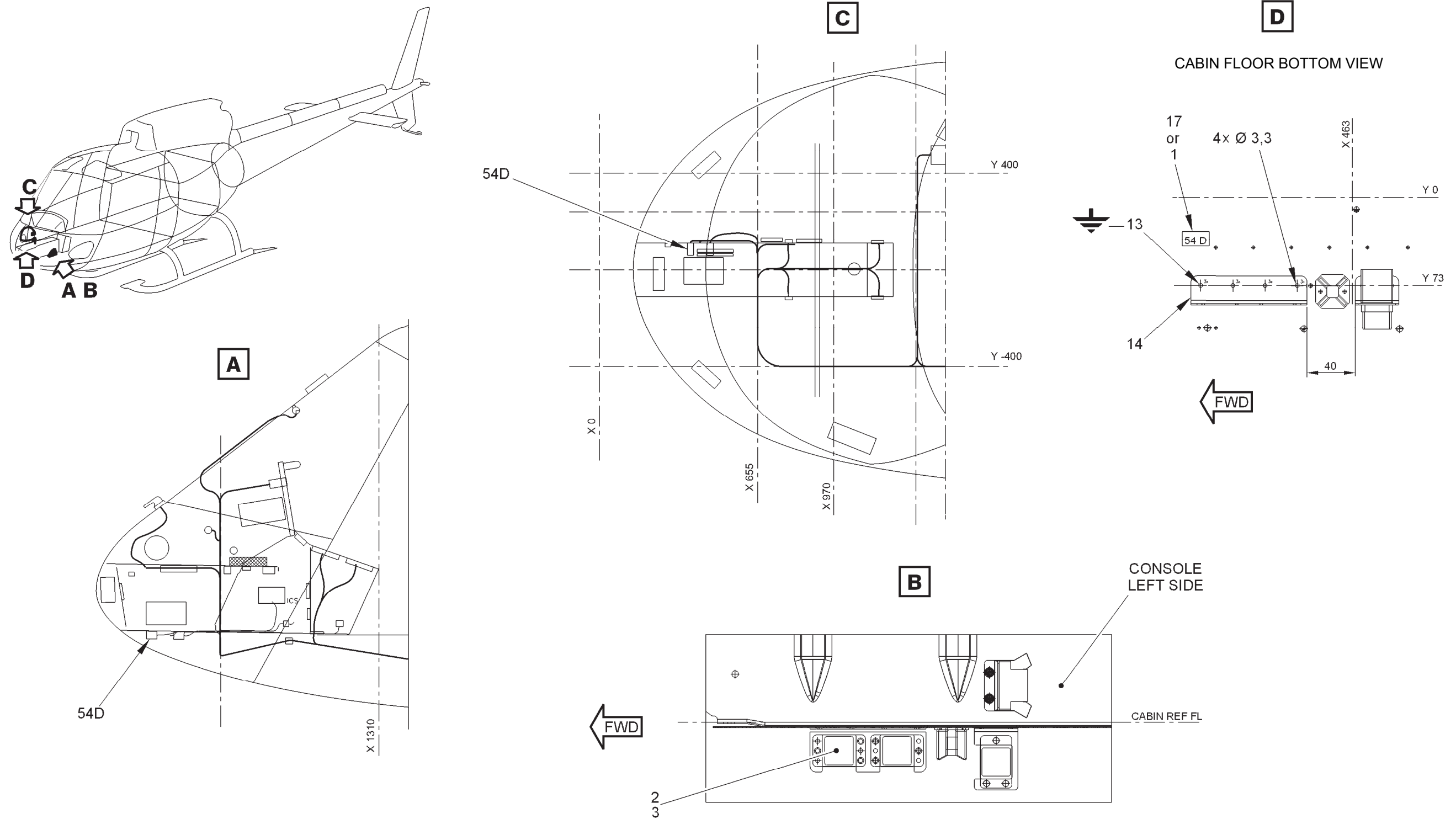
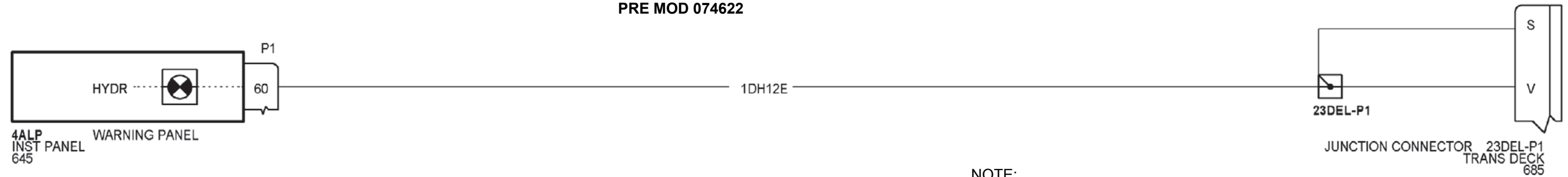

Figure 1

PAGE LEFT BLANK INTENTIONALLY

POST MOD 073450 and PRE MOD 075601
POST MOD 075601 and PRE MOD 074280
PRE MOD 074622



NOTE:
UNLESS OTHERWISE SPECIFIED ALL WIRES ARE: CF22
UNLESS OTHERWISE SPECIFIED ALL ROUTES ARE: 1BA0

POST MOD 073450 and PRE MOD 075601
POST MOD 075601 and PRE MOD 074280
POST MOD 074622

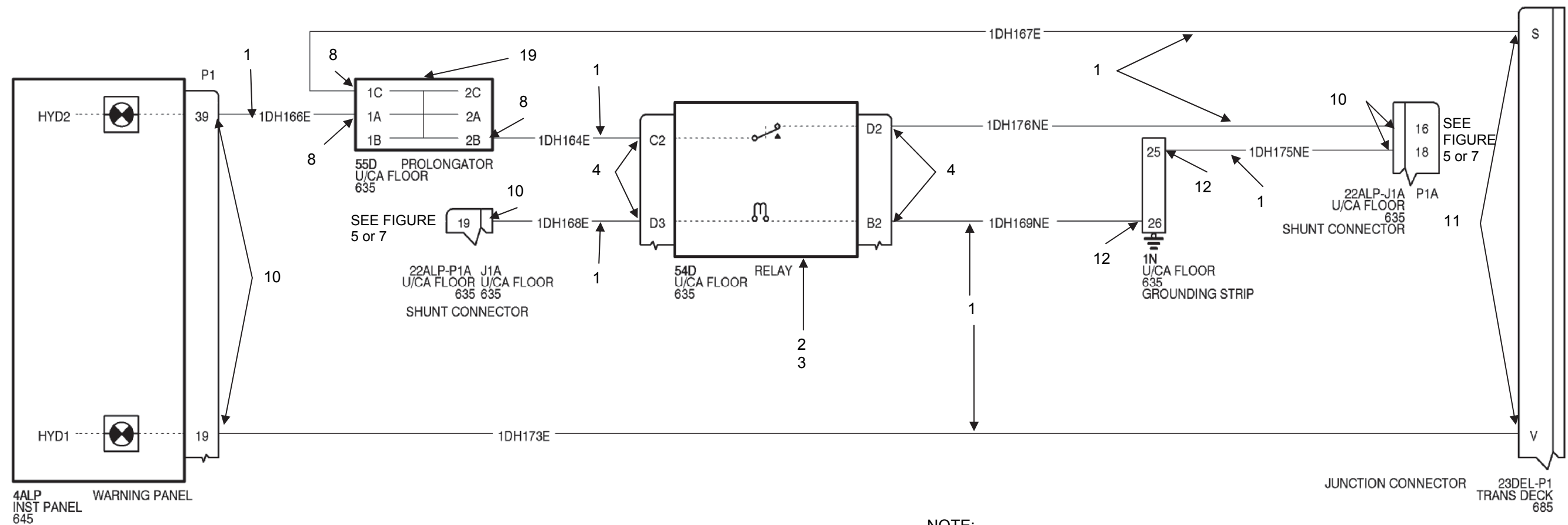

NOTE:
UNLESS OTHERWISE SPECIFIED ALL WIRES ARE: DR22
UNLESS OTHERWISE SPECIFIED ALL ROUTES ARE: 1BA0

Figure 2

PAGE LEFT BLANK INTENTIONALLY

POST MOD 074280 and PRE MOD 075606
POST MOD 075606
PRE MOD 074622

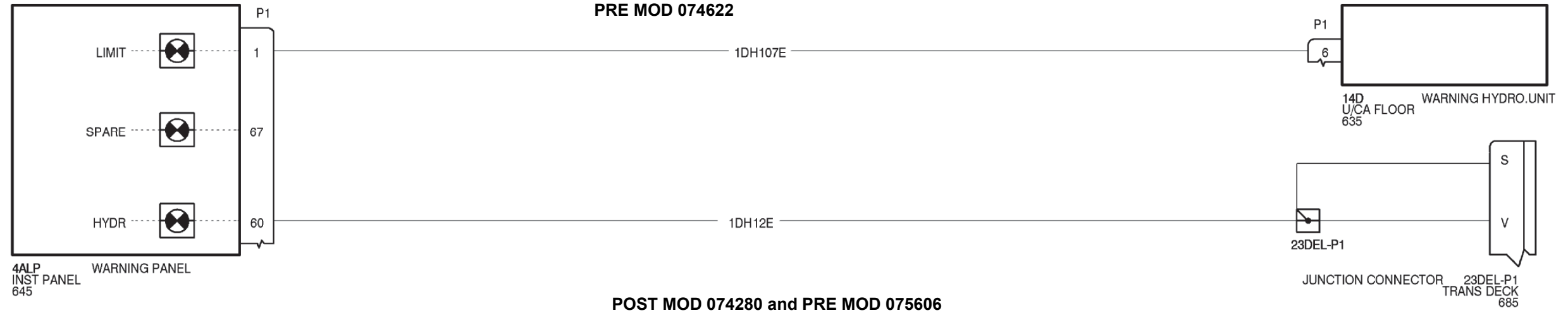

POST MOD 074280 and PRE MOD 075606
POST MOD 075606
POST MOD 074622

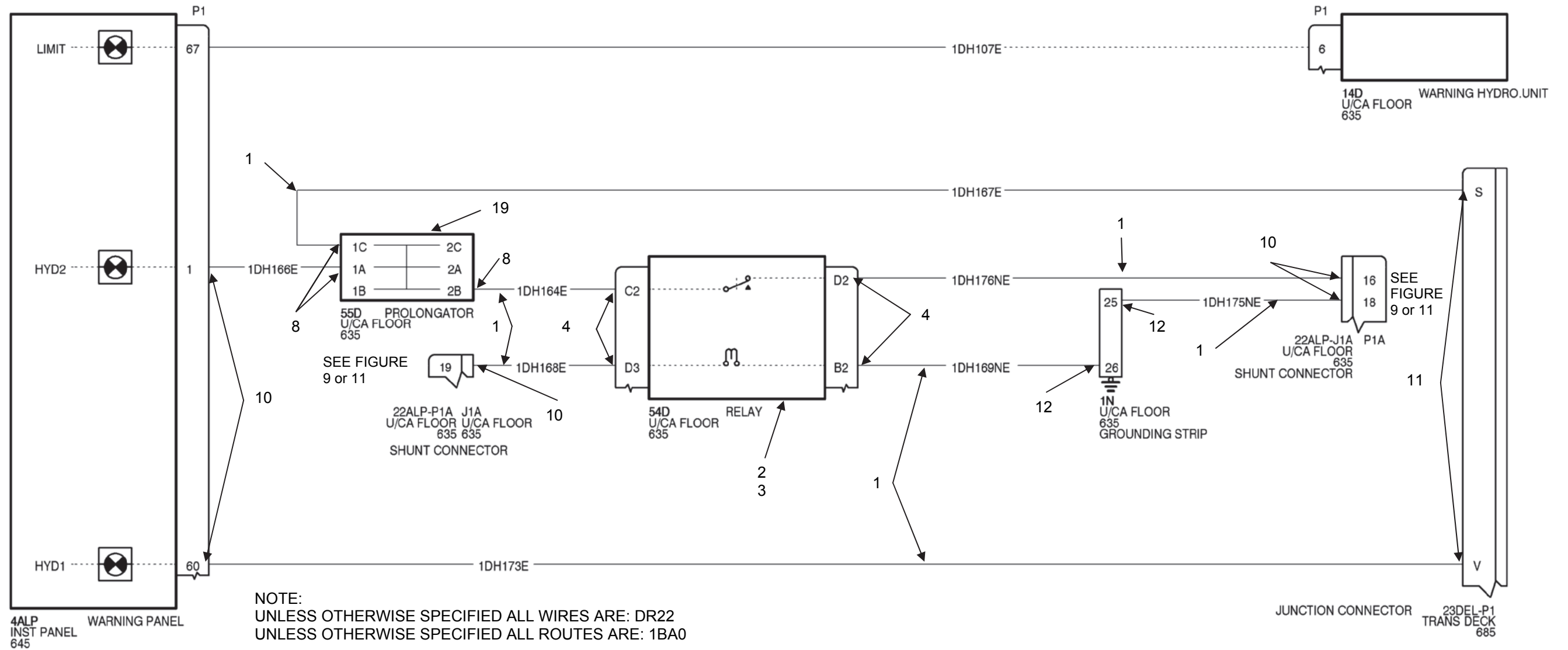
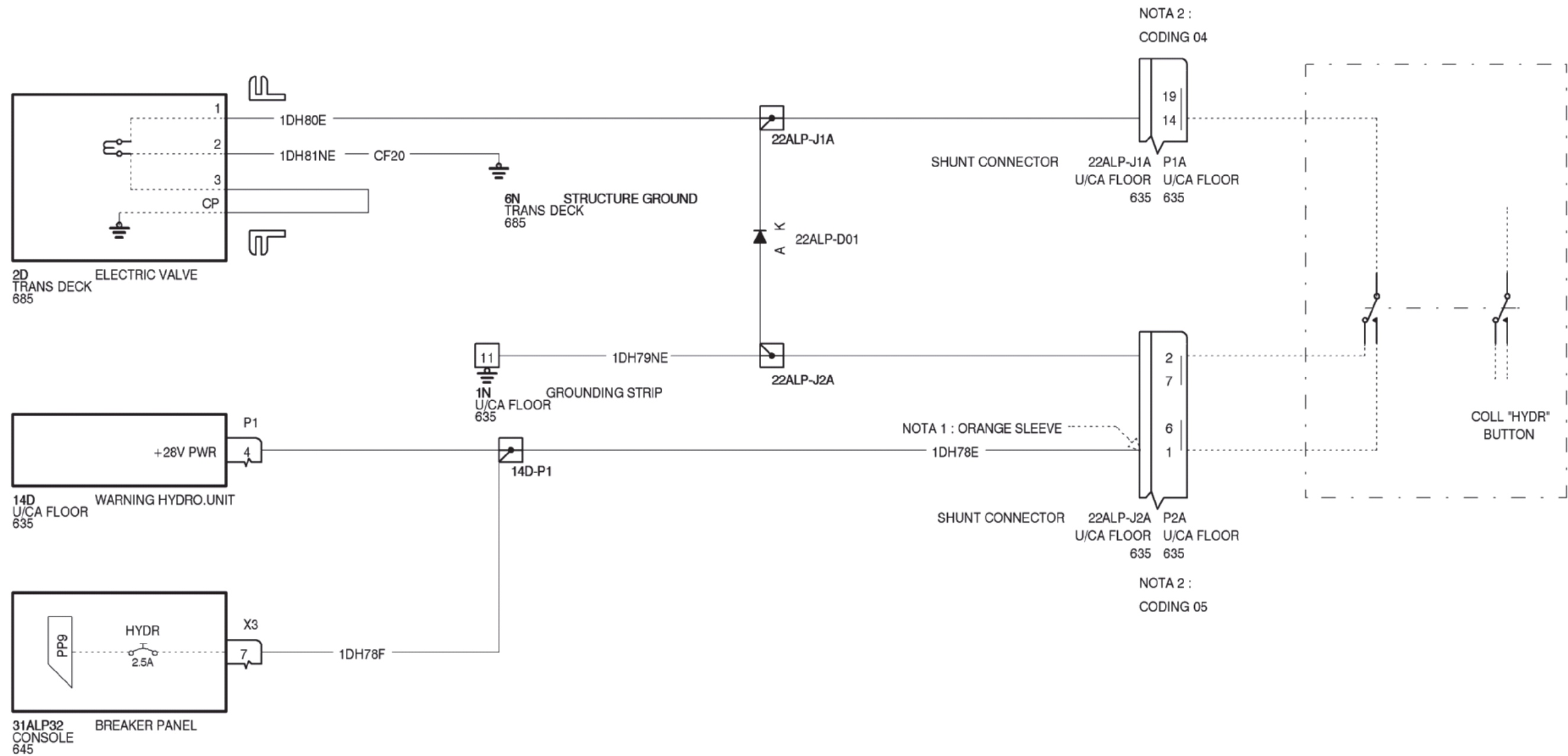

Figure 3

PAGE LEFT BLANK INTENTIONALLY

POST MOD 073450 and PRE MOD 075601
PRE MOD 074622



NOTE:
UNLESS OTHERWISE SPECIFIED ALL WIRES ARE: CF22
UNLESS OTHERWISE SPECIFIED ALL ROUTES ARE: 1BA0

Figure 4

PAGE LEFT BLANK INTENTIONALLY

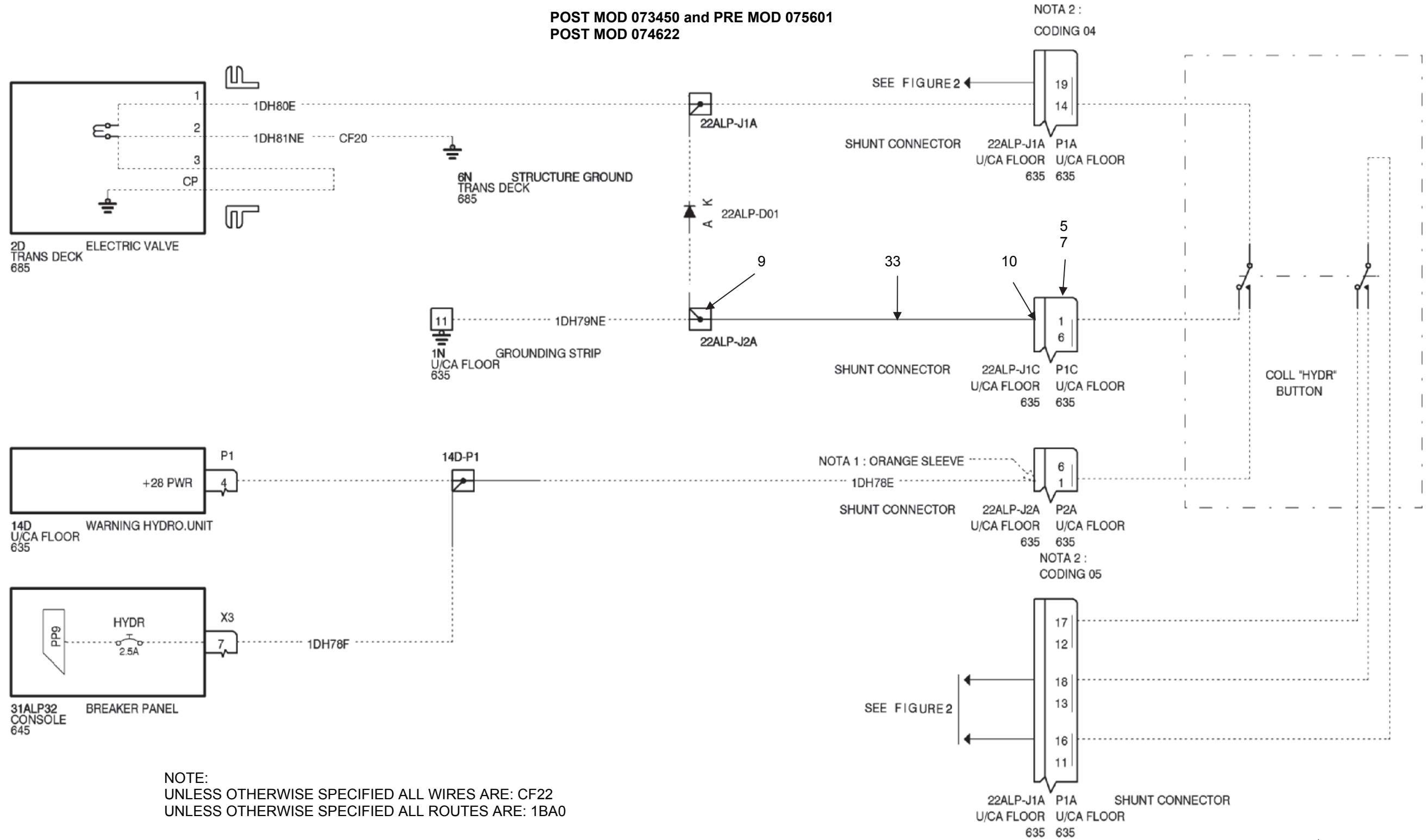
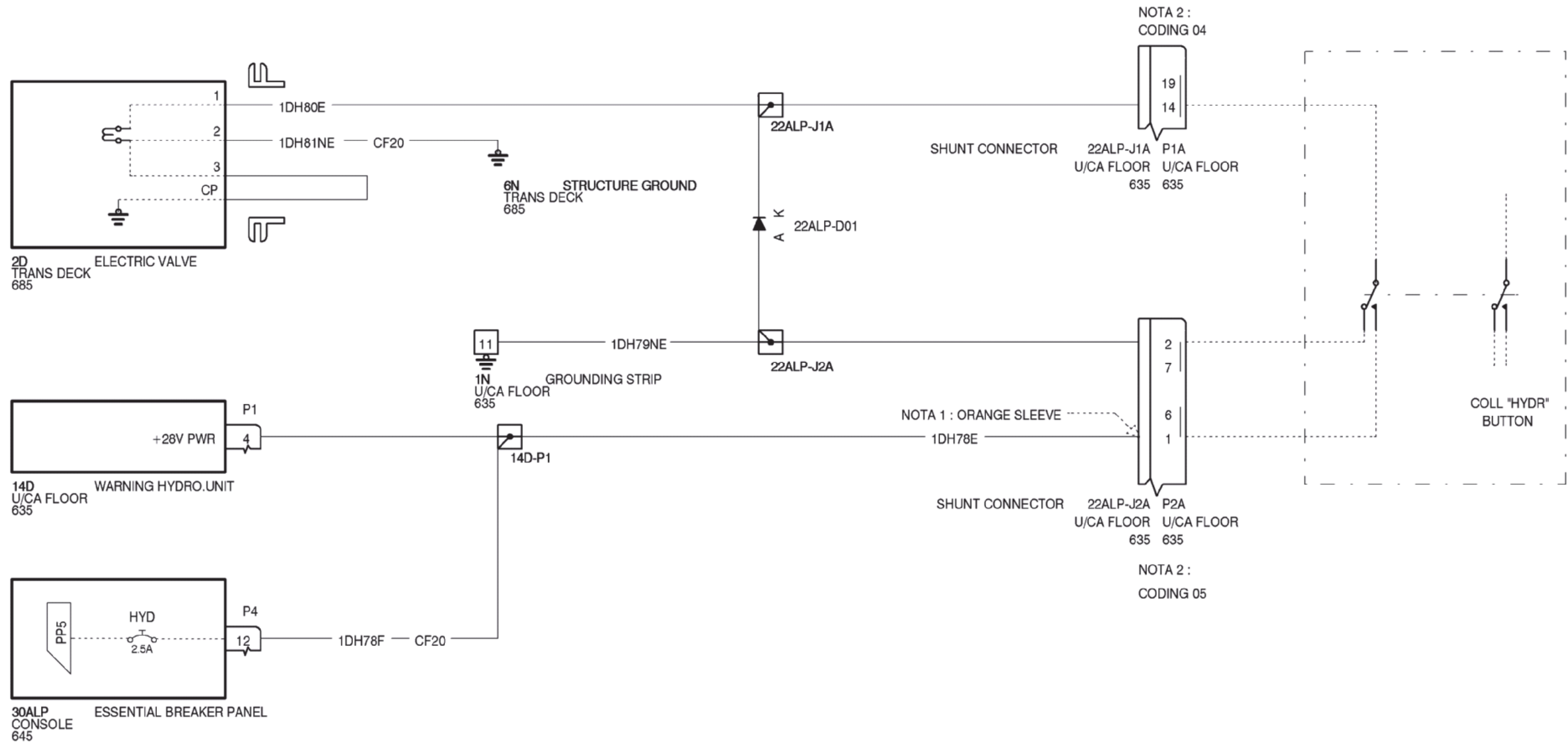

Figure 5

PAGE LEFT BLANK INTENTIONALLY

POST MOD 075601 and PRE MOD 074280
PRE MOD 074622



NOTE:
UNLESS OTHERWISE SPECIFIED ALL WIRES ARE: CF22
UNLESS OTHERWISE SPECIFIED ALL ROUTES ARE: 1BA0

Figure 6

PAGE LEFT BLANK INTENTIONALLY

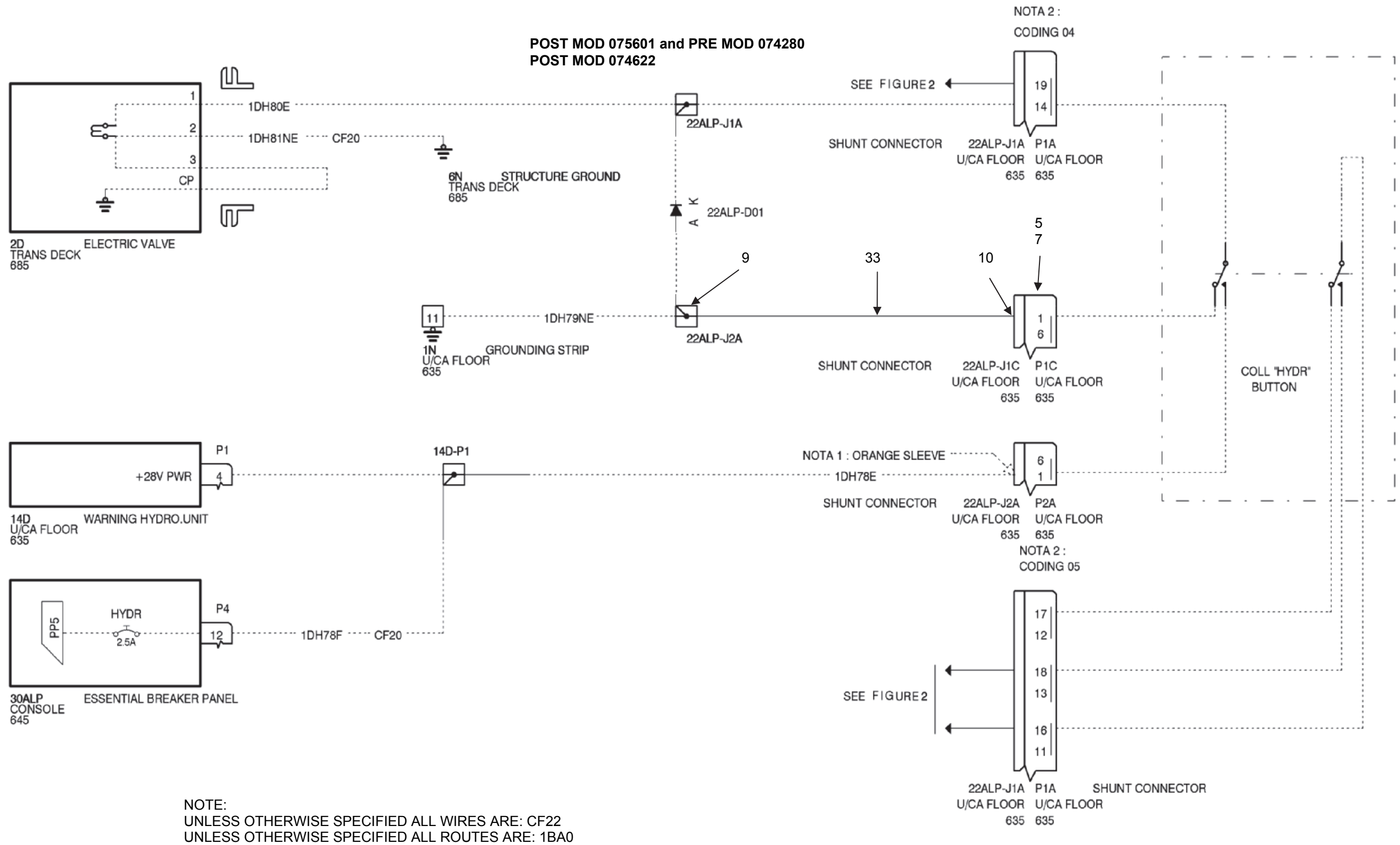
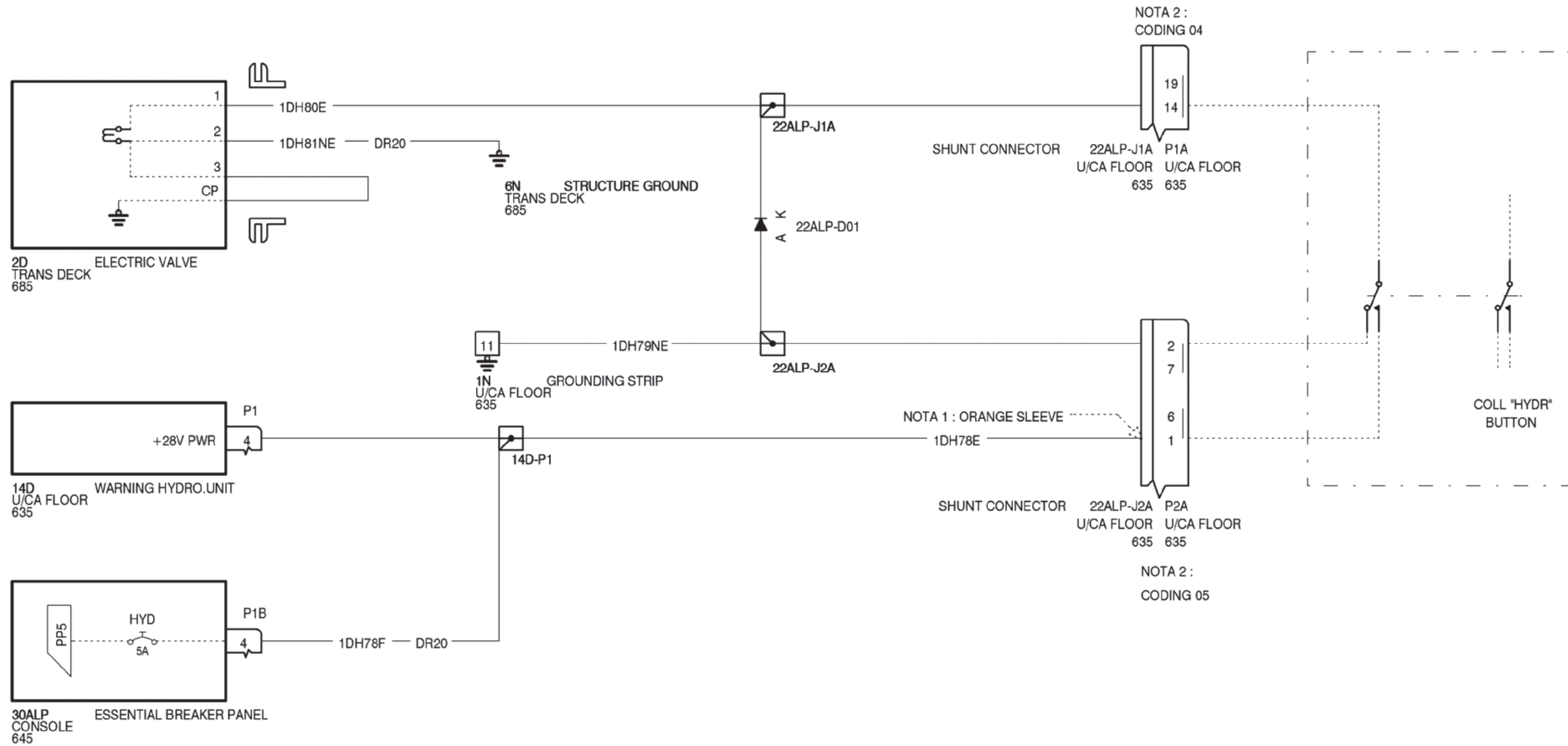

Figure 7

PAGE LEFT BLANK INTENTIONALLY

**POST MOD 074280 and PRE MOD 075606
PRE MOD 074622**



NOTE:
UNLESS OTHERWISE SPECIFIED ALL WIRES ARE: DR22
UNLESS OTHERWISE SPECIFIED ALL ROUTES ARE: 1BA0

Figure 8

PAGE LEFT BLANK INTENTIONALLY

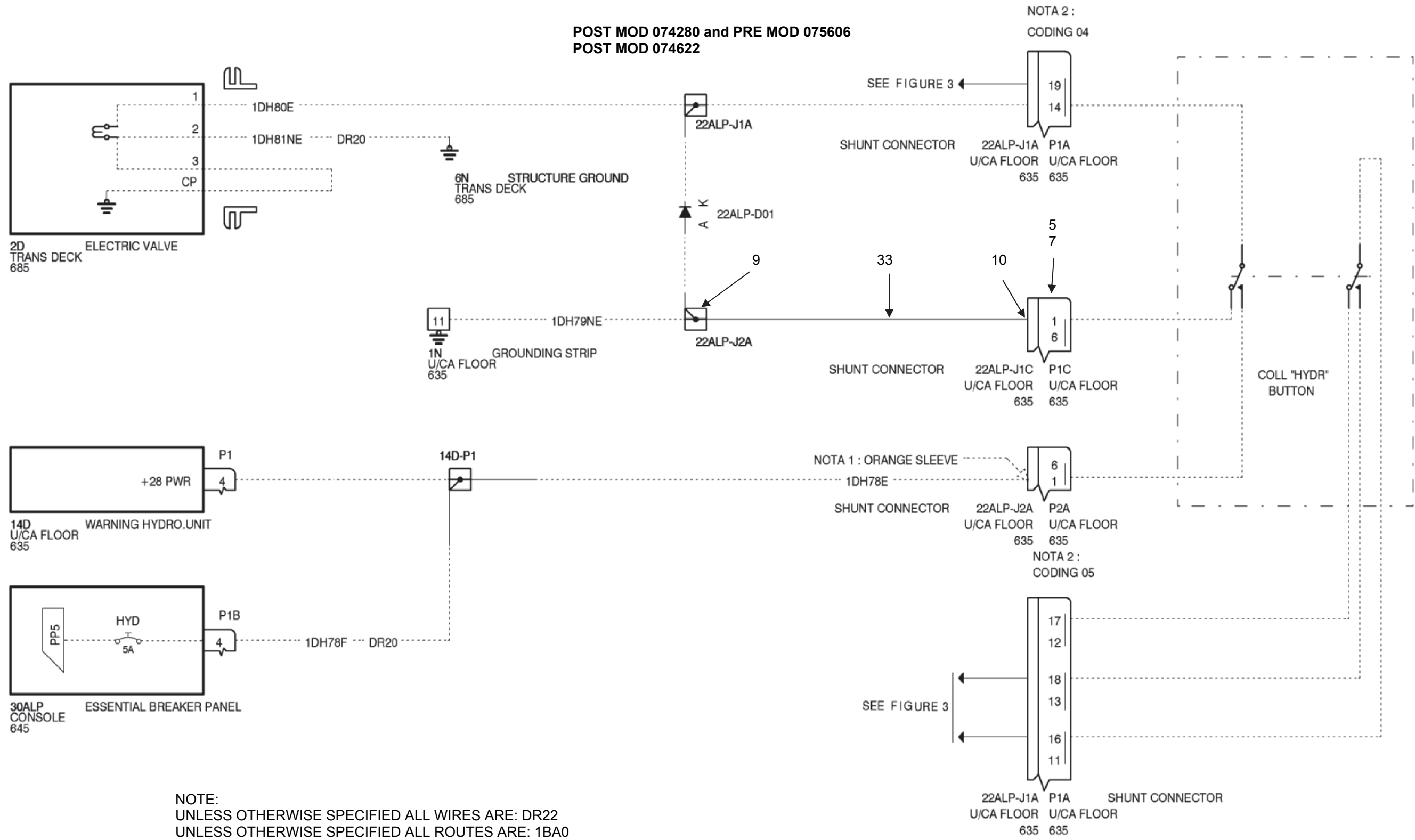

Figure 9

PAGE LEFT BLANK INTENTIONALLY

POST MOD 075606
PRE MOD 074622

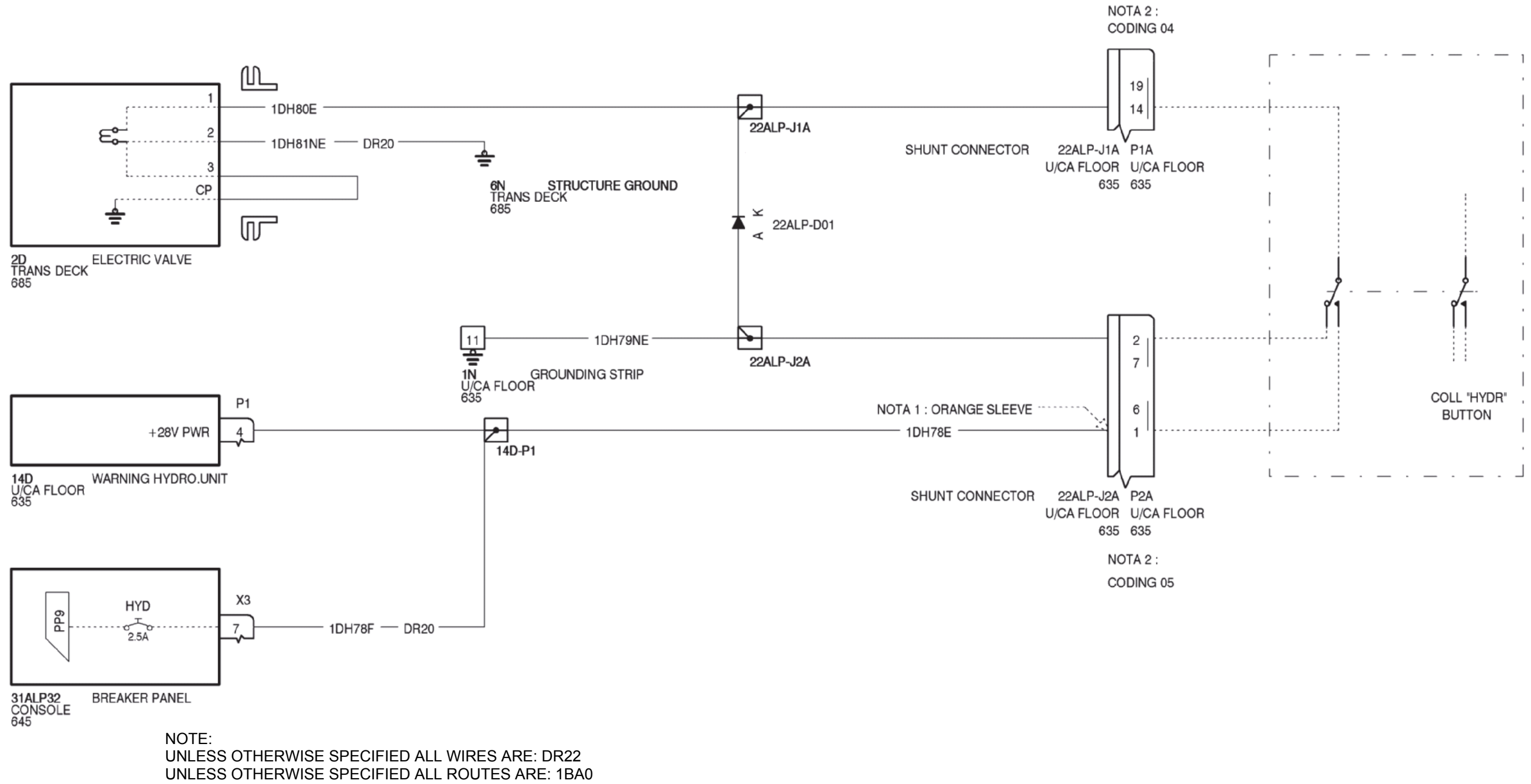
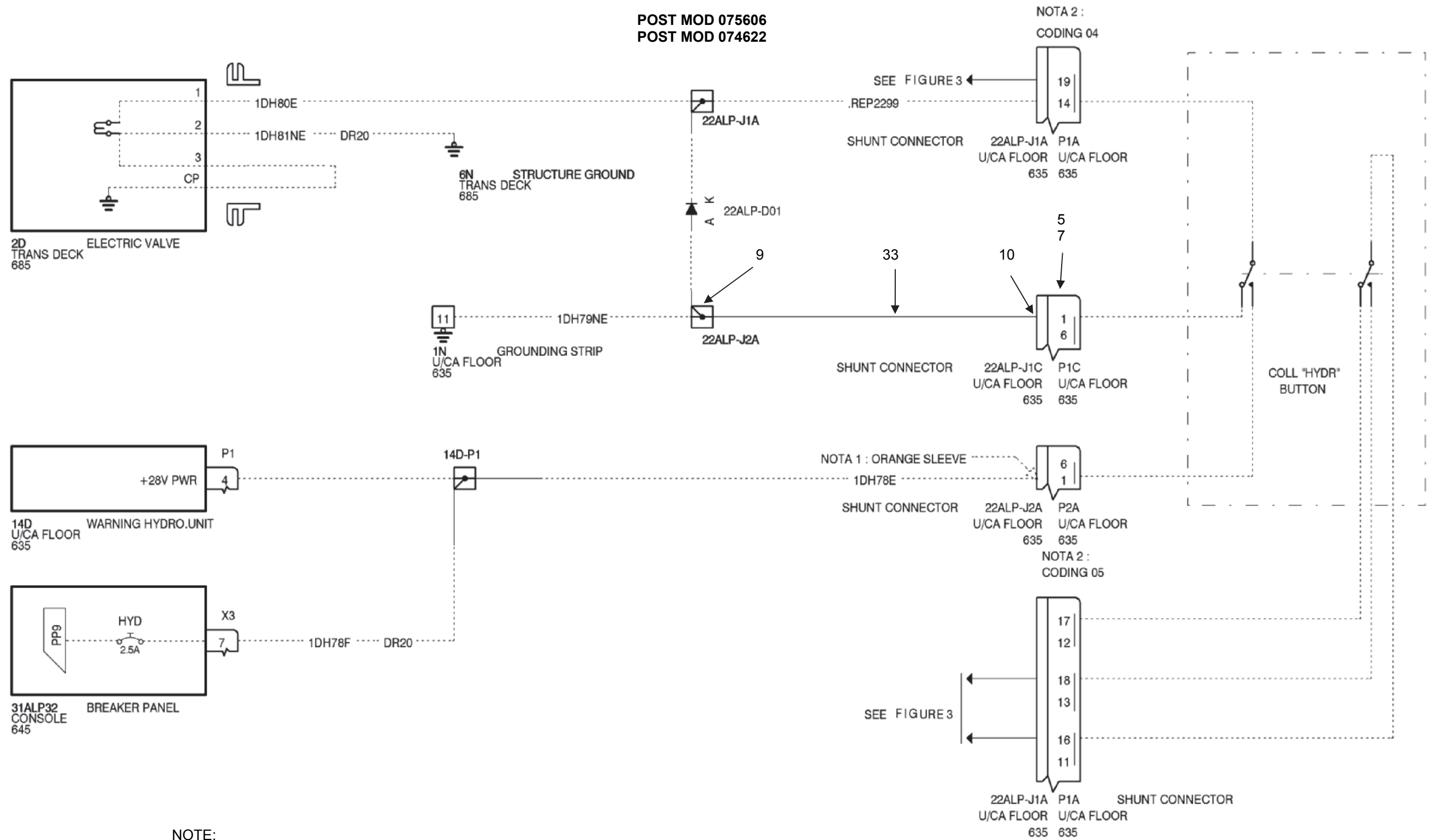

Figure 10

PAGE LEFT BLANK INTENTIONALLY



NOTE:
UNLESS OTHERWISE SPECIFIED ALL WIRES ARE: DR22
UNLESS OTHERWISE SPECIFIED ALL ROUTES ARE: 1BA0

Figure 11

PAGE LEFT BLANK INTENTIONALLY

POST MOD 073450 and PRE MOD 075601
POST MOD 075601 and PRE MOD 074280
PRE MOD 074622

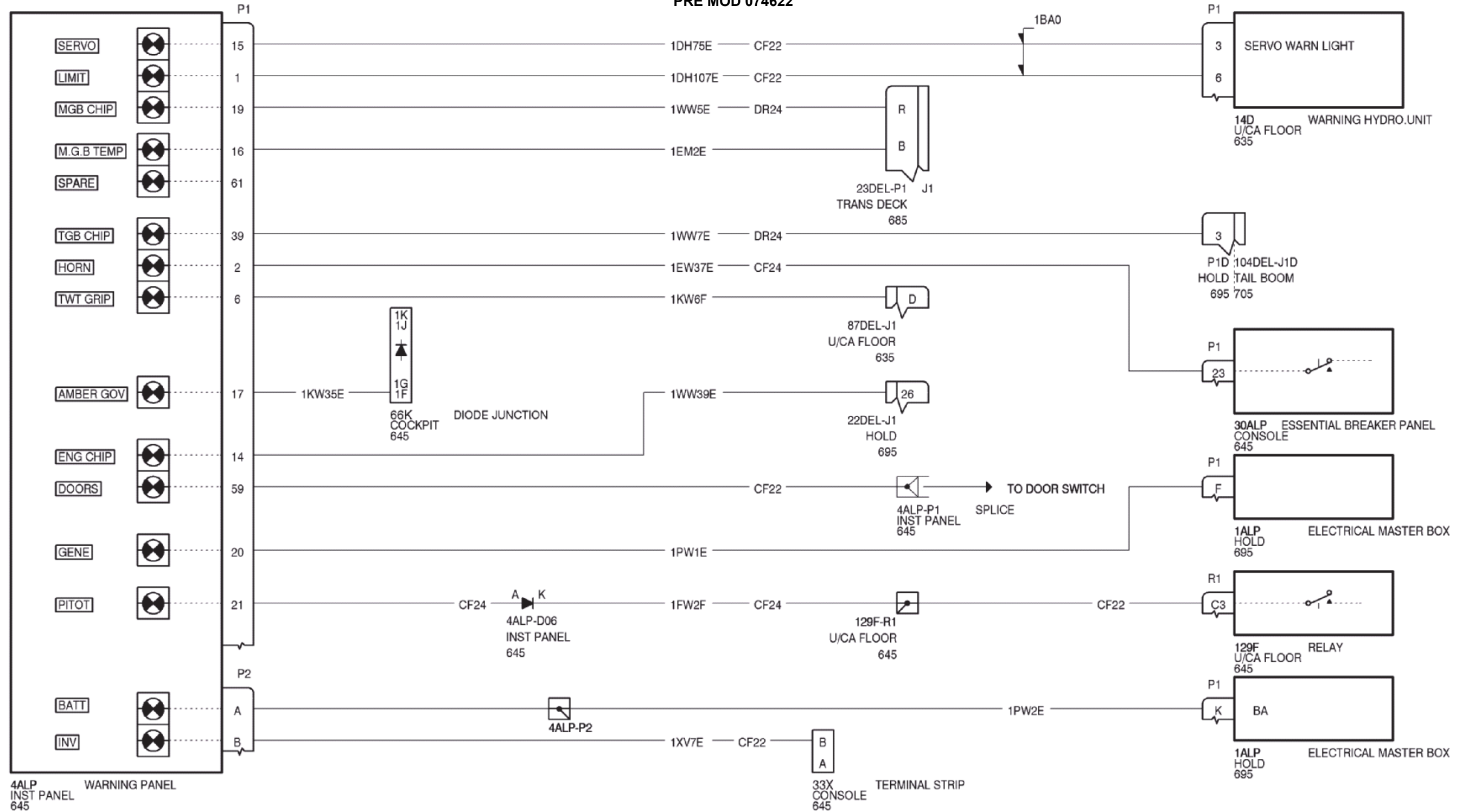

NOTE:
UNLESS OTHERWISE SPECIFIED ALL WIRES ARE: DR22
UNLESS OTHERWISE SPECIFIED ALL ROUTES ARE: 1BA

Figure 12

PAGE LEFT BLANK INTENTIONALLY

POST MOD 073450 and PRE MOD 075601
POST MOD 075601 and PRE MOD 074280
POST MOD 074622

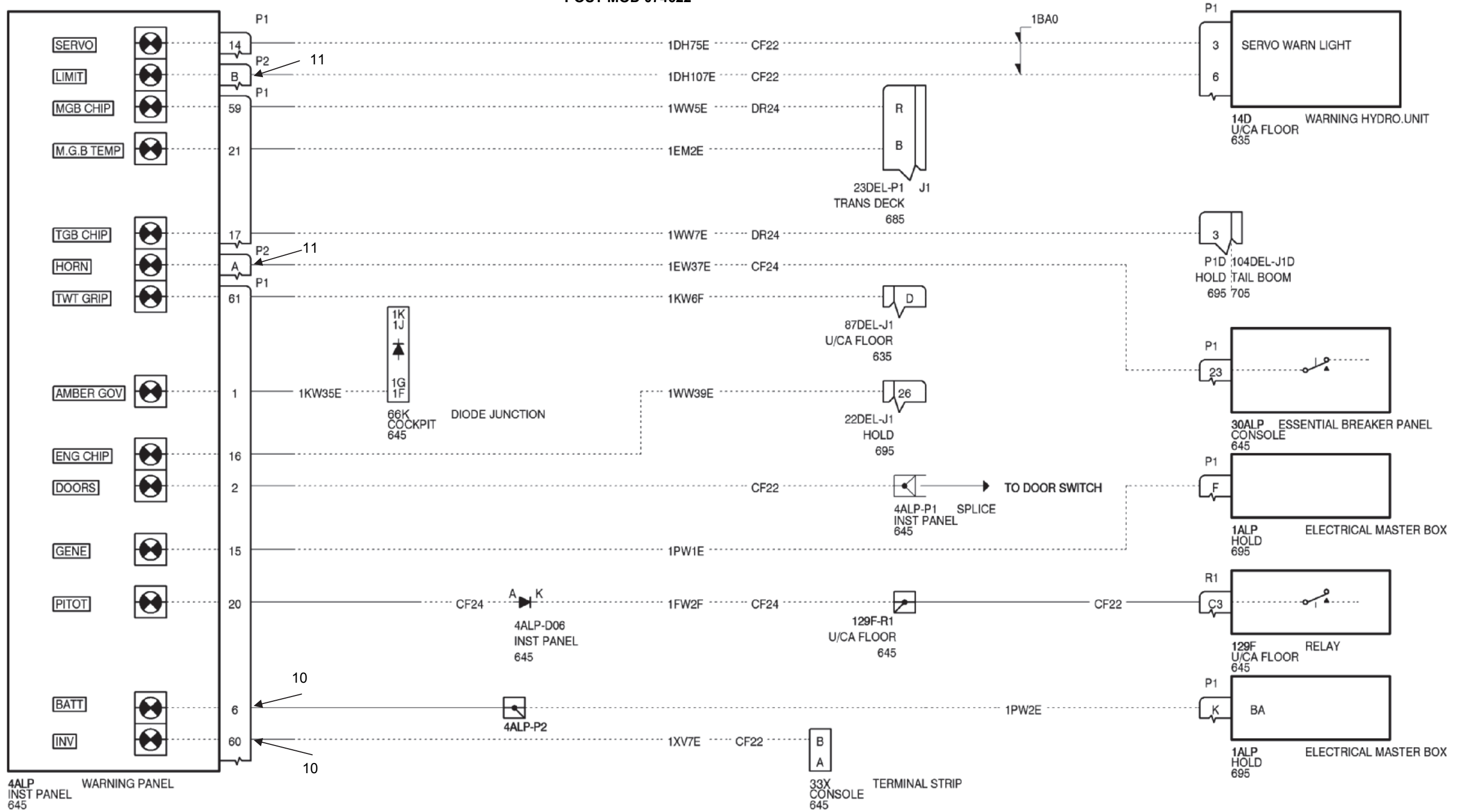

NOTE:
UNLESS OTHERWISE SPECIFIED ALL WIRES ARE: DR22
UNLESS OTHERWISE SPECIFIED ALL ROUTES ARE: 1BA

Figure 13

PAGE LEFT BLANK INTENTIONALLY

**POST OP3346 and PRE MOD 073368
PRE MOD 074622**

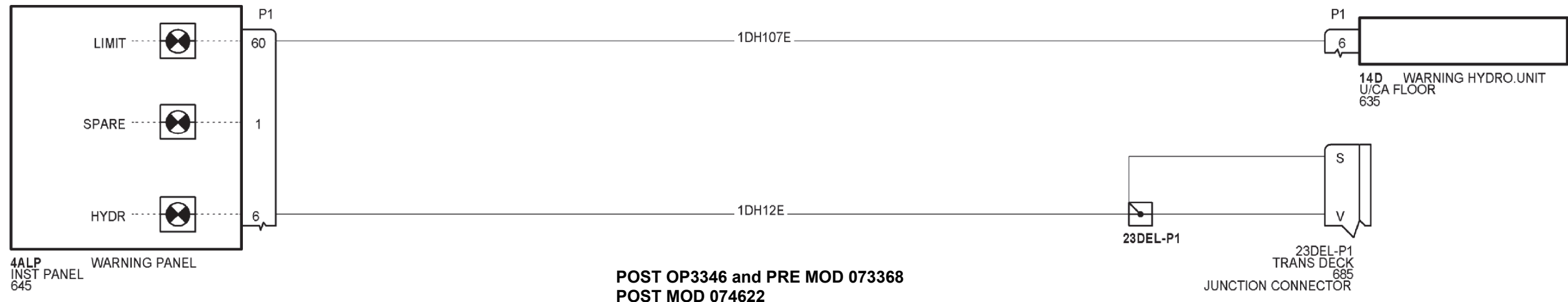

**POST OP3346 and PRE MOD 073368
POST MOD 074622**

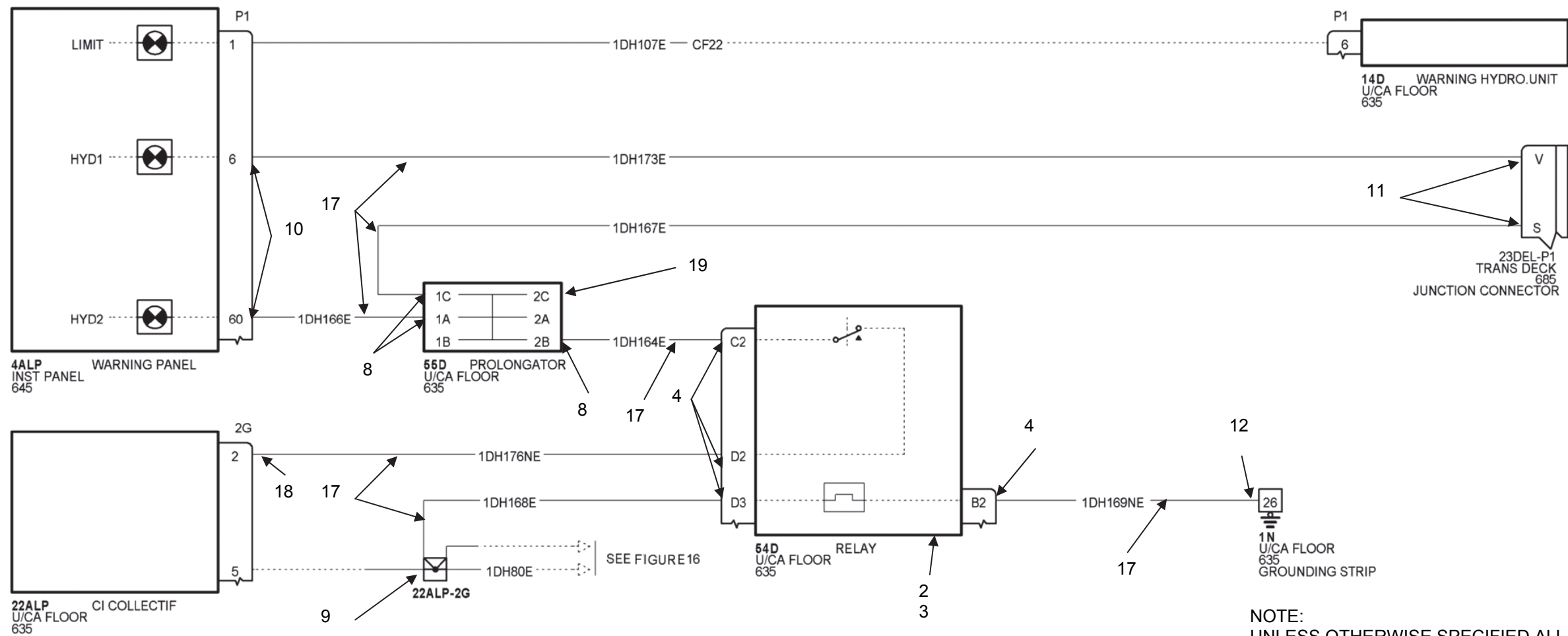

NOTE:
UNLESS OTHERWISE SPECIFIED ALL WIRES ARE: DR22
UNLESS OTHERWISE SPECIFIED ALL ROUTES ARE: 1BA0

Figure 14

PAGE LEFT BLANK INTENTIONALLY

POST OP3346 and PRE MOD 073368
POST MOD 073368 and POST MOD 073391 and PRE MOD 073450
PRE MOD 074622

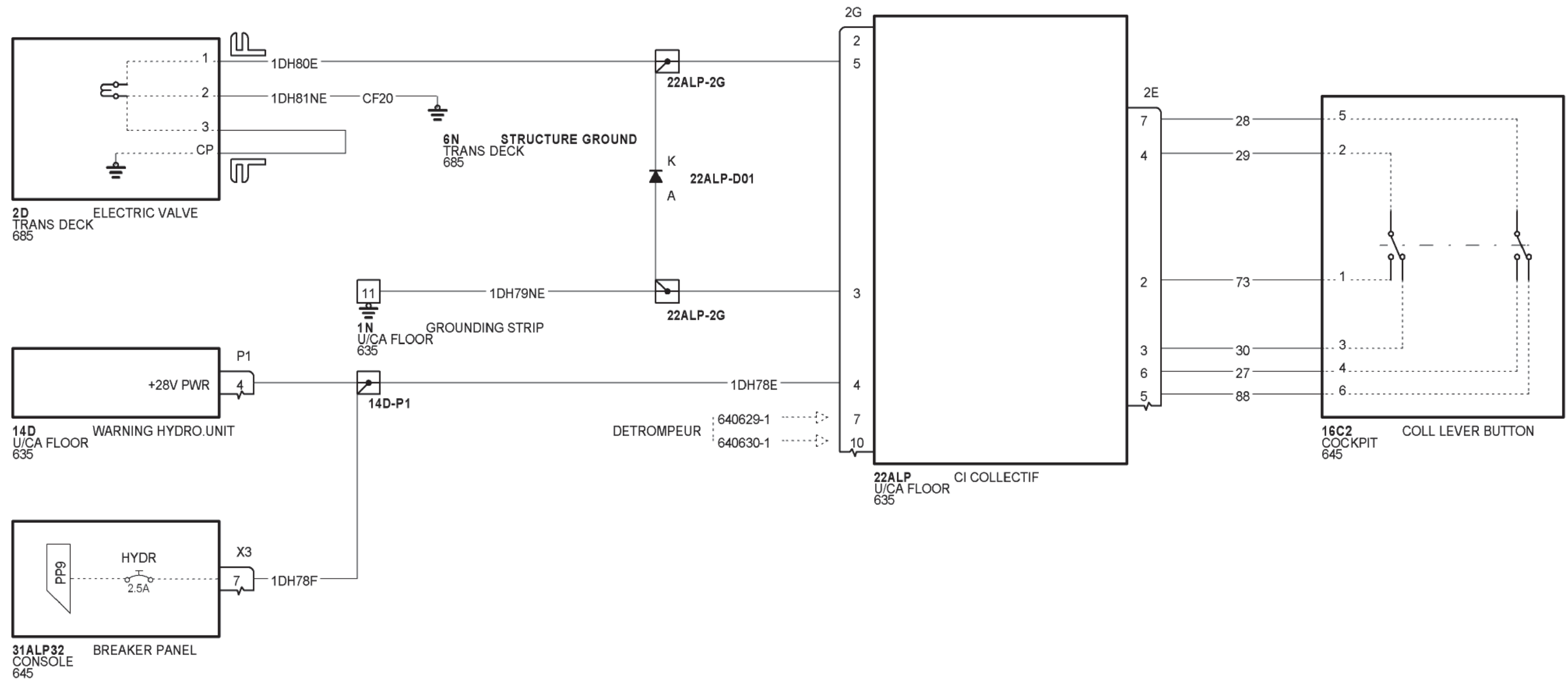

NOTE:
UNLESS OTHERWISE SPECIFIED ALL WIRES ARE: CF22
UNLESS OTHERWISE SPECIFIED ALL ROUTES ARE: 1BA0

Figure 15

PAGE LEFT BLANK INTENTIONALLY

POST OP3346 and PRE MOD 073368
POST MOD 073368 and POST MOD 073391 and PRE MOD 073450
POST MOD 074622

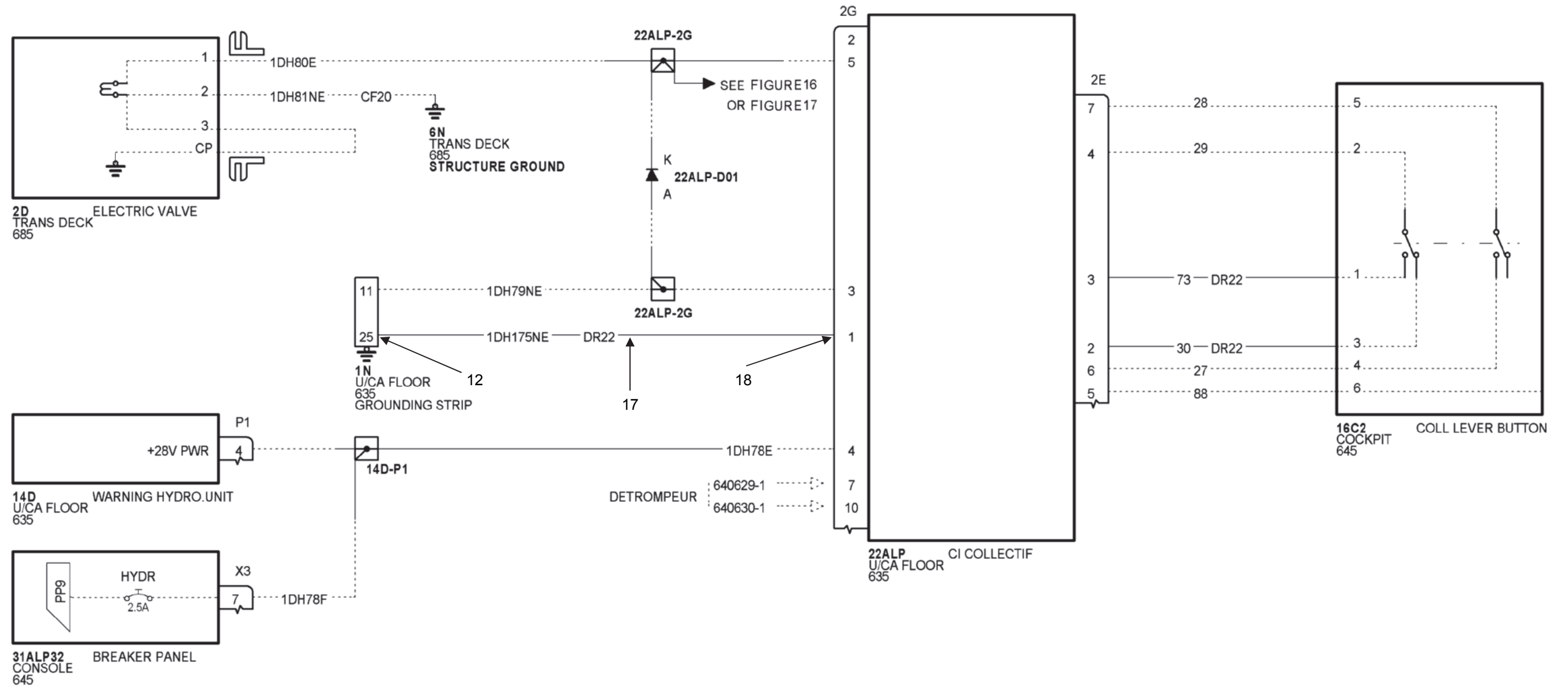

NOTE:
UNLESS OTHERWISE SPECIFIED ALL WIRES ARE: CF22
UNLESS OTHERWISE SPECIFIED ALL ROUTES ARE: 1BA0

Figure 16

PAGE LEFT BLANK INTENTIONALLY

**POST MOD 073368 and POST MOD 073391 and PRE MOD 073450
PRE MOD 074622**

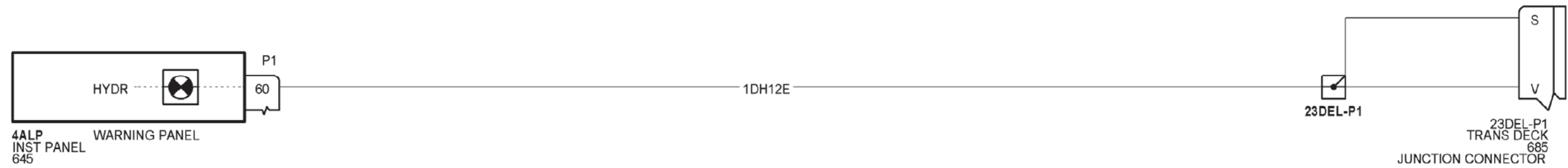

**POST MOD 073368 and POST MOD 073391 and PRE MOD 073450
POST MOD 074622**

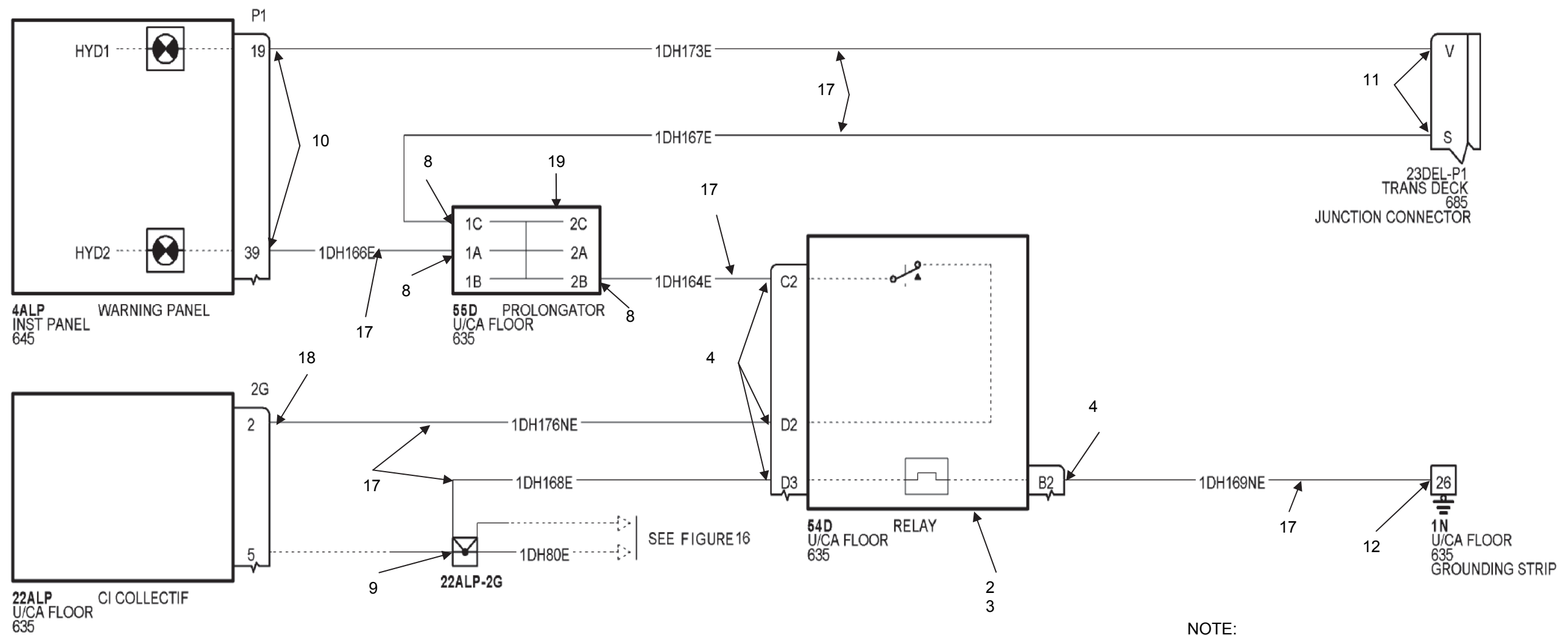

NOTE:
UNLESS OTHERWISE SPECIFIED ALL WIRES ARE: CF22
UNLESS OTHERWISE SPECIFIED ALL ROUTES ARE: 1BA0

Figure 17

PAGE LEFT BLANK INTENTIONALLY

POST MOD 073368 and POST MOD 073391 and PRE MOD 073450
PRE MOD 074622

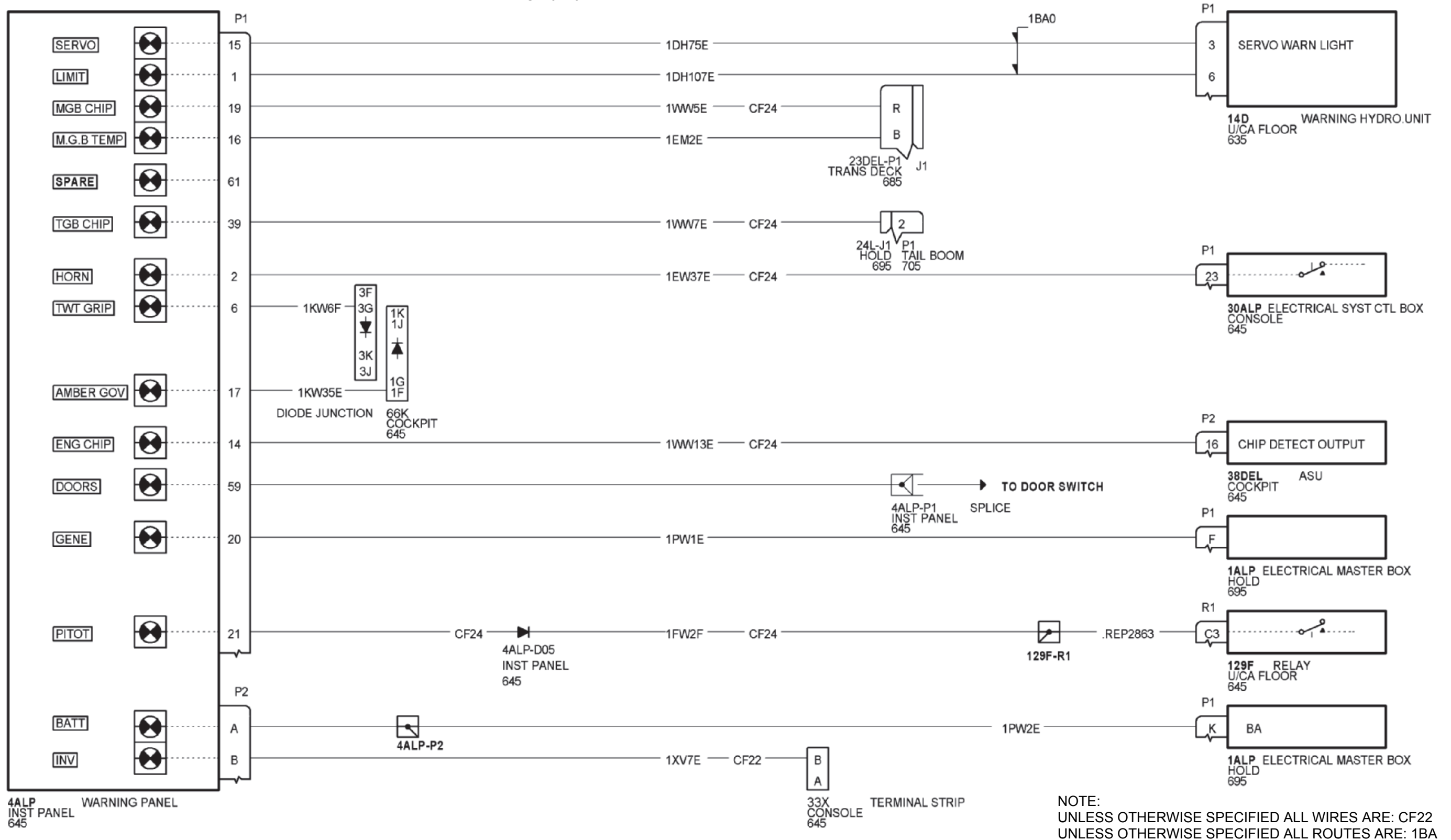

Figure 18

PAGE LEFT BLANK INTENTIONALLY

POST MOD 073368 and POST MOD 073391 and PRE MOD 073450
POST MOD 074622

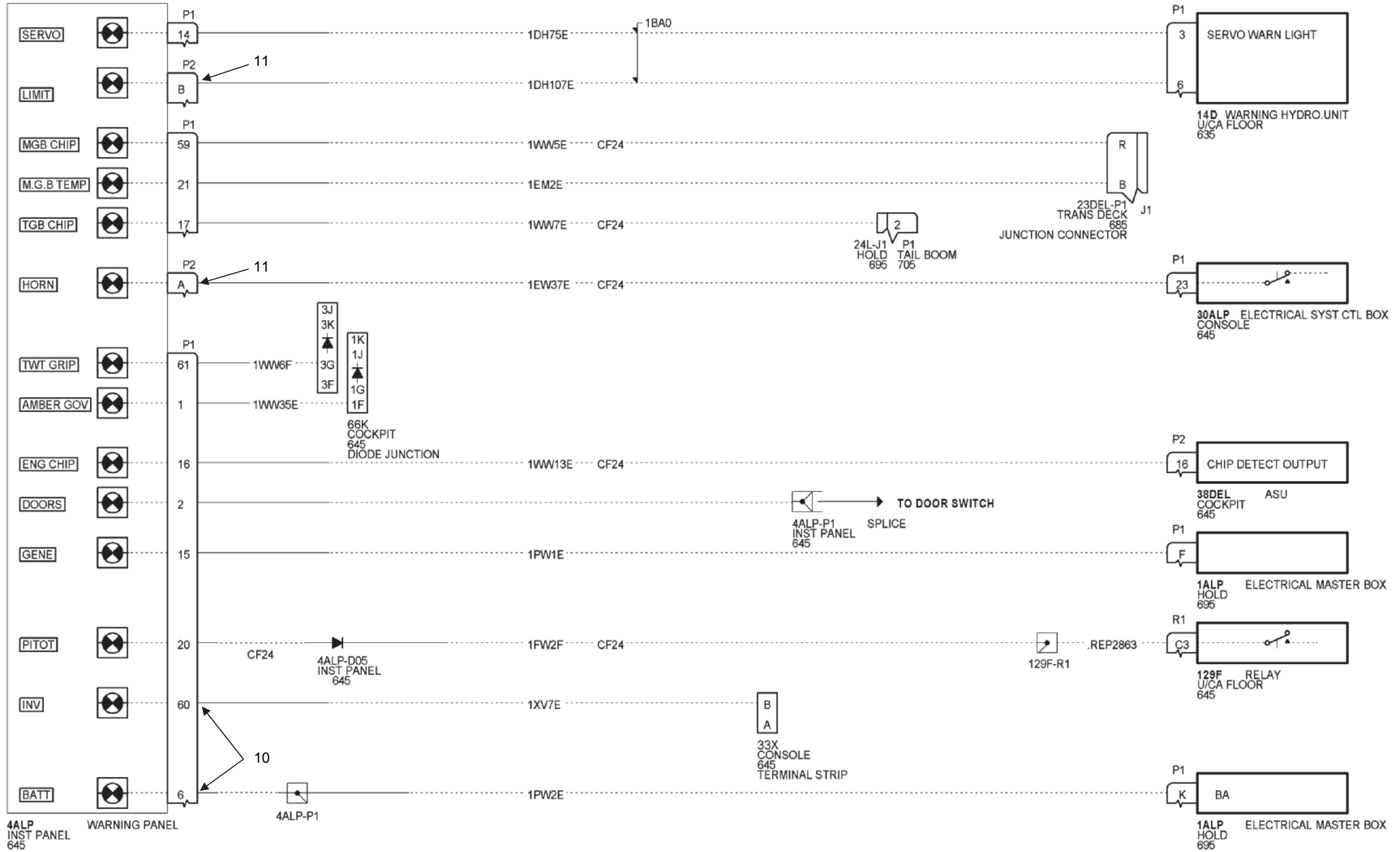
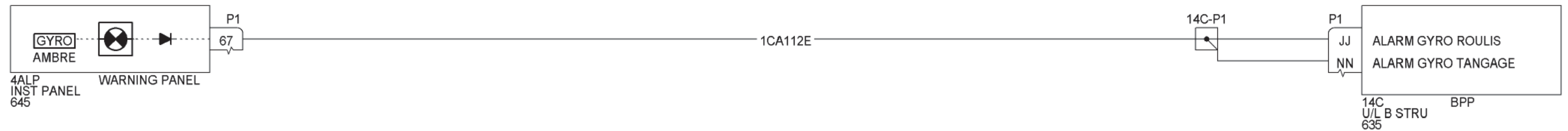

Figure 19

NOTE:
UNLESS OTHERWISE SPECIFIED ALL WIRES ARE: CF22
UNLESS OTHERWISE SPECIFIED ALL ROUTES ARE: 1BA

PAGE LEFT BLANK INTENTIONALLY

PRE MOD 074622



POST MOD 074622

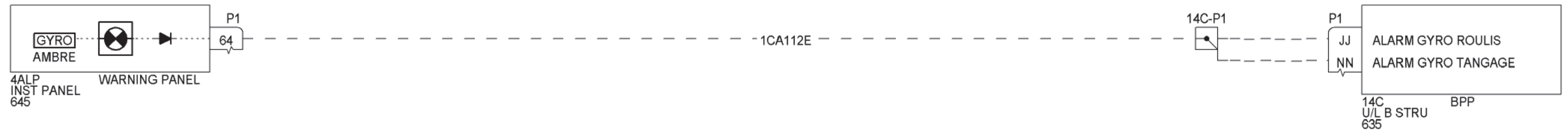

Figure 20 – A.P. fixed parts

PAGE LEFT BLANK INTENTIONALLY

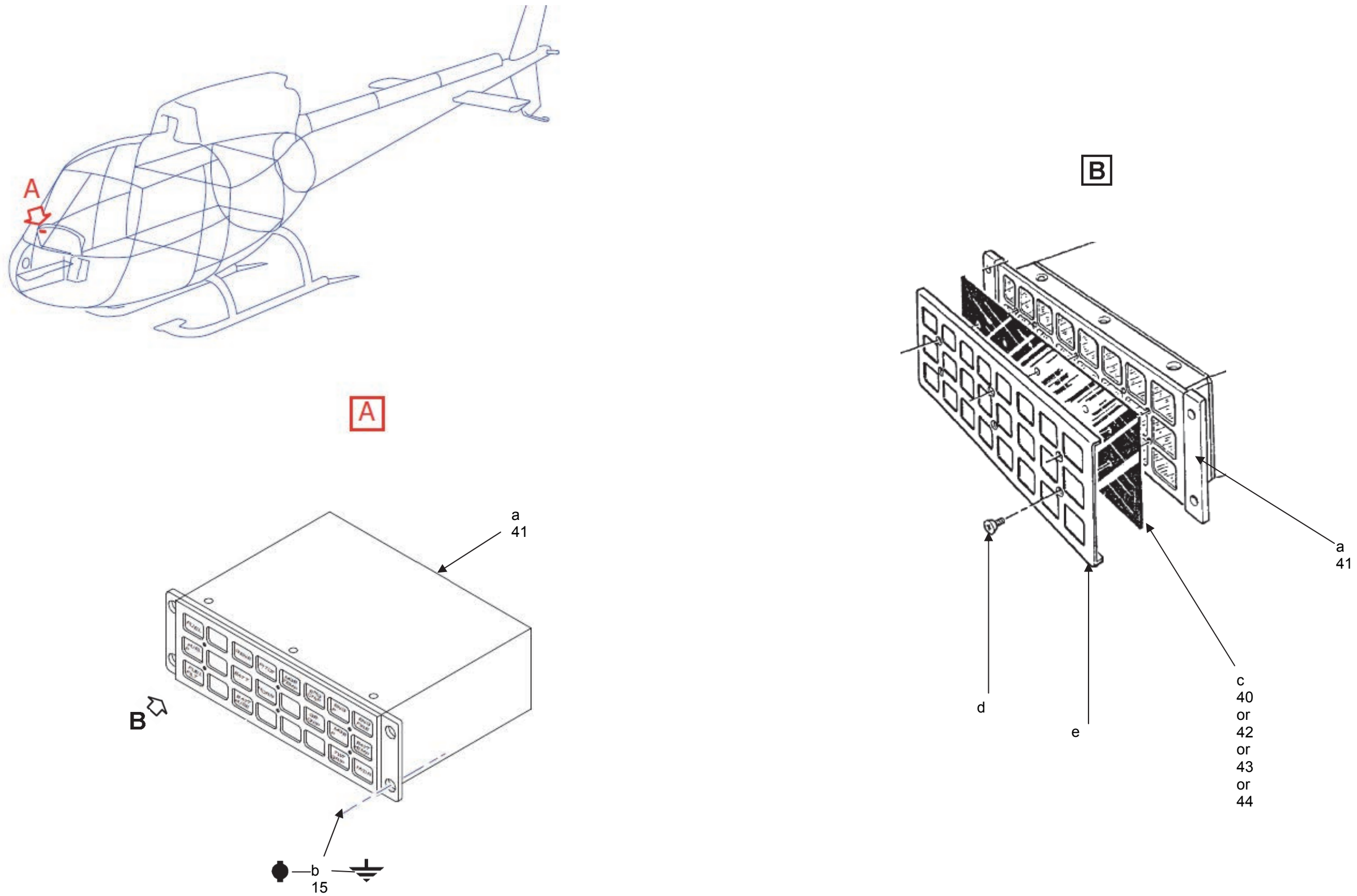

Figure 21

PAGE LEFT BLANK INTENTIONALLY

4. APPENDIX
4.A. TOOLING TO BE USED FOR CONTACTS 130743-1

Contact P/N	Gage	Length to be stripped	Crimping pliers	Extractor
130743-1	22	6.3 mm	45098	305183

4.B. TOOLING TO BE USED FOR CONTACTS 770522-1

Contact P/N	Gage	Crimping pliers	Position	Adjust.	Extractor	Intensity
770522-1	22	90123-2 or 91512-1	B	1	90471.1	6.5 A