

DOCKET No.: SA-521
EXHIBIT No. 7I

NATIONAL TRANSPORTATION SAFETY BOARD
WASHINGTON, D.C.

AIRWORTHINESS GROUP CHAIRMAN'S FACTUAL REPORT
ATTACHMENT VIII: Schematic, Elevator Control System

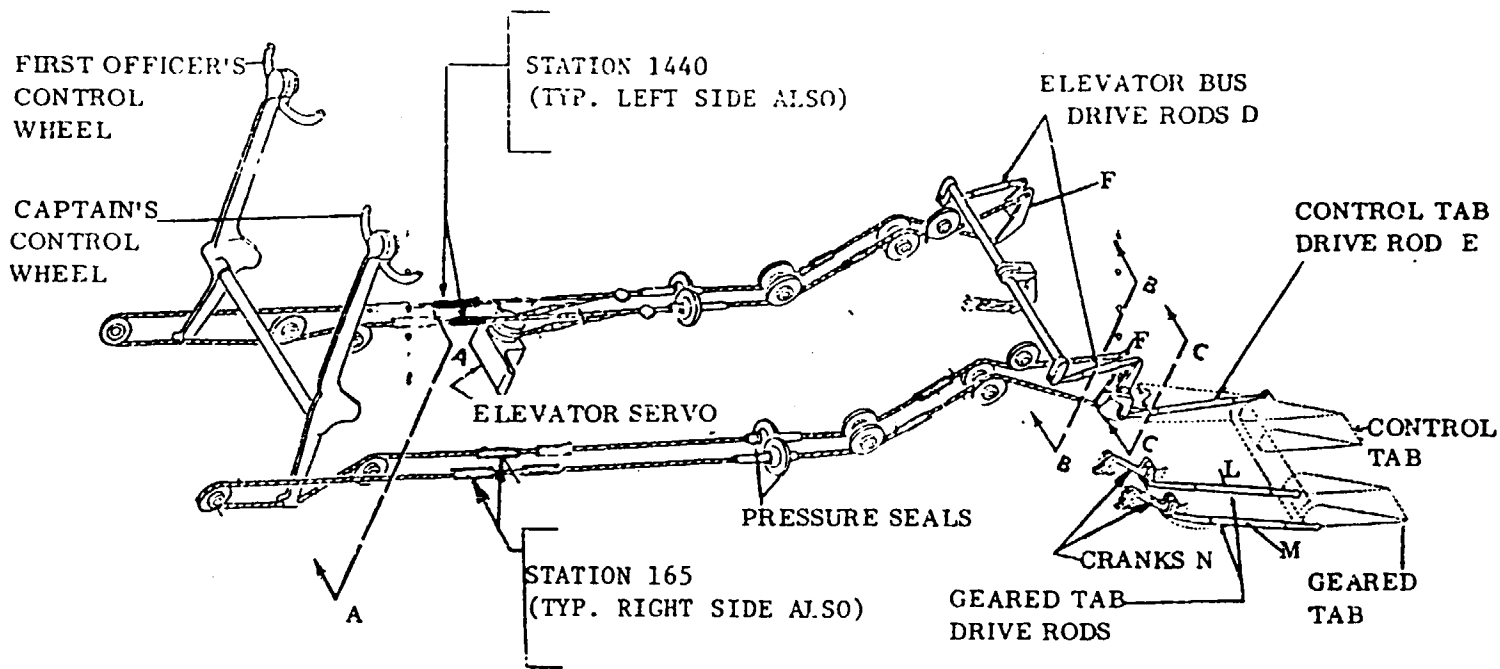

FIGURE 201 (SHEET 1 OF 3) - ELEVATOR CONTROL SYSTEM

7

TMA 4761/C/11161N
 EFF: EC8-71 N8070U-99U
 NR177U

DC8MM

CONTINUED
 27-30-03
 Page 206
 Jan 30/86

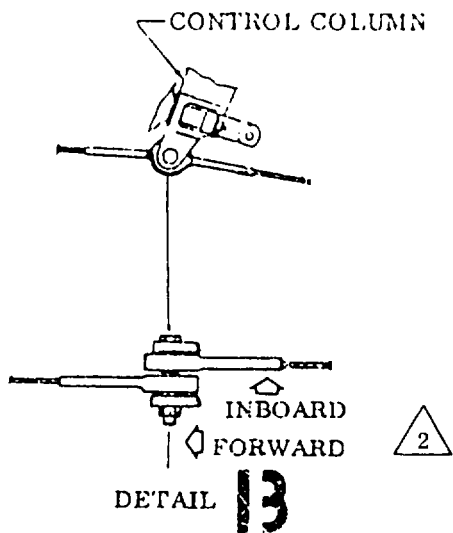
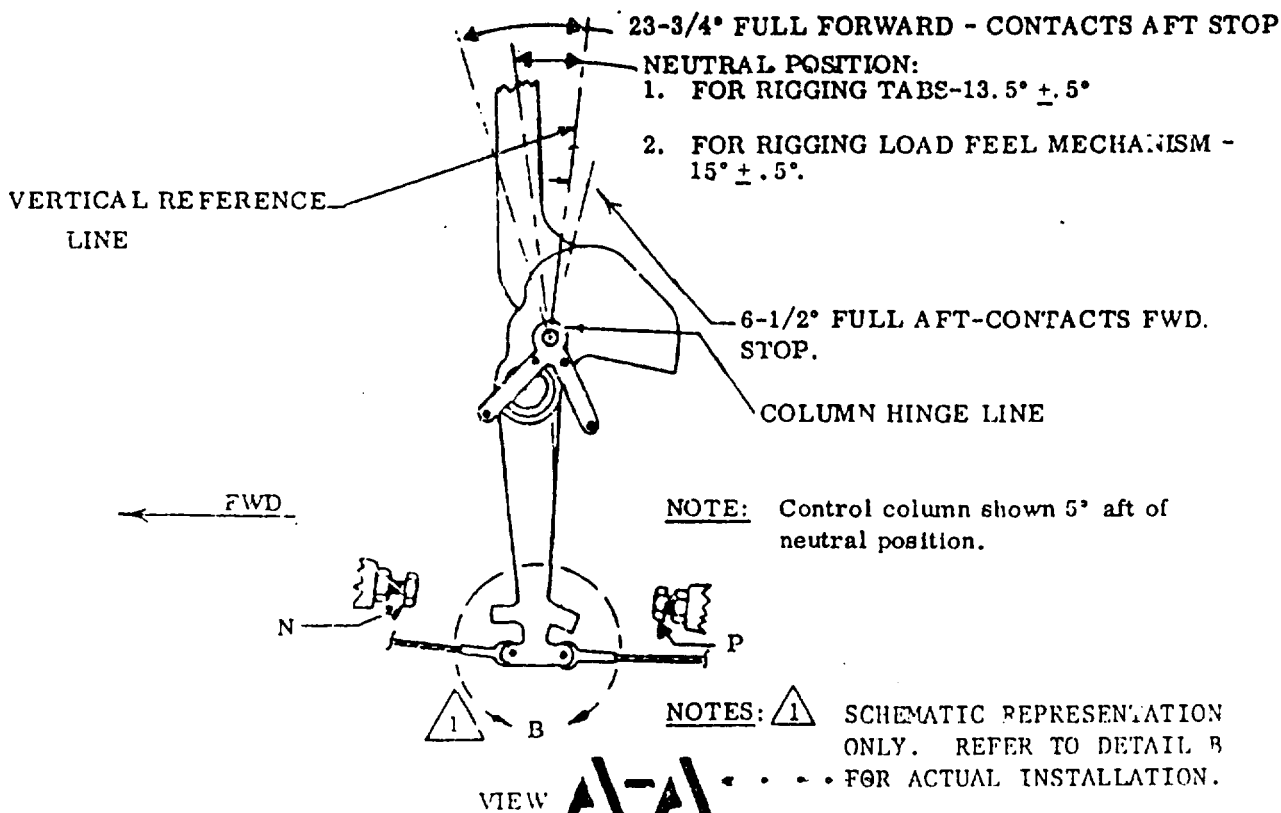

$\triangle 2$ Cable running aft is mounted inboard of cable running forward.

FIGURE 201 (SHEET 2 OF 3) - ELEVATOR CONTROL SYSTEM

2

TMA 4761/C/1161N

EFF: DC8-71 N8070U-99U
 N8177U

DC8MM

CONTINUED
 27-30-03
 Page 207
 Jan 30/86

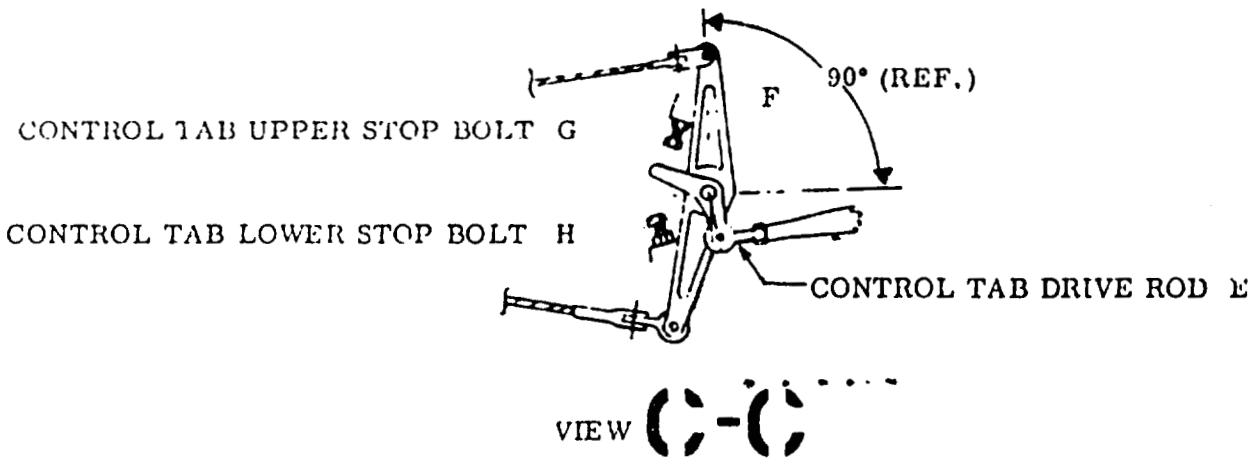
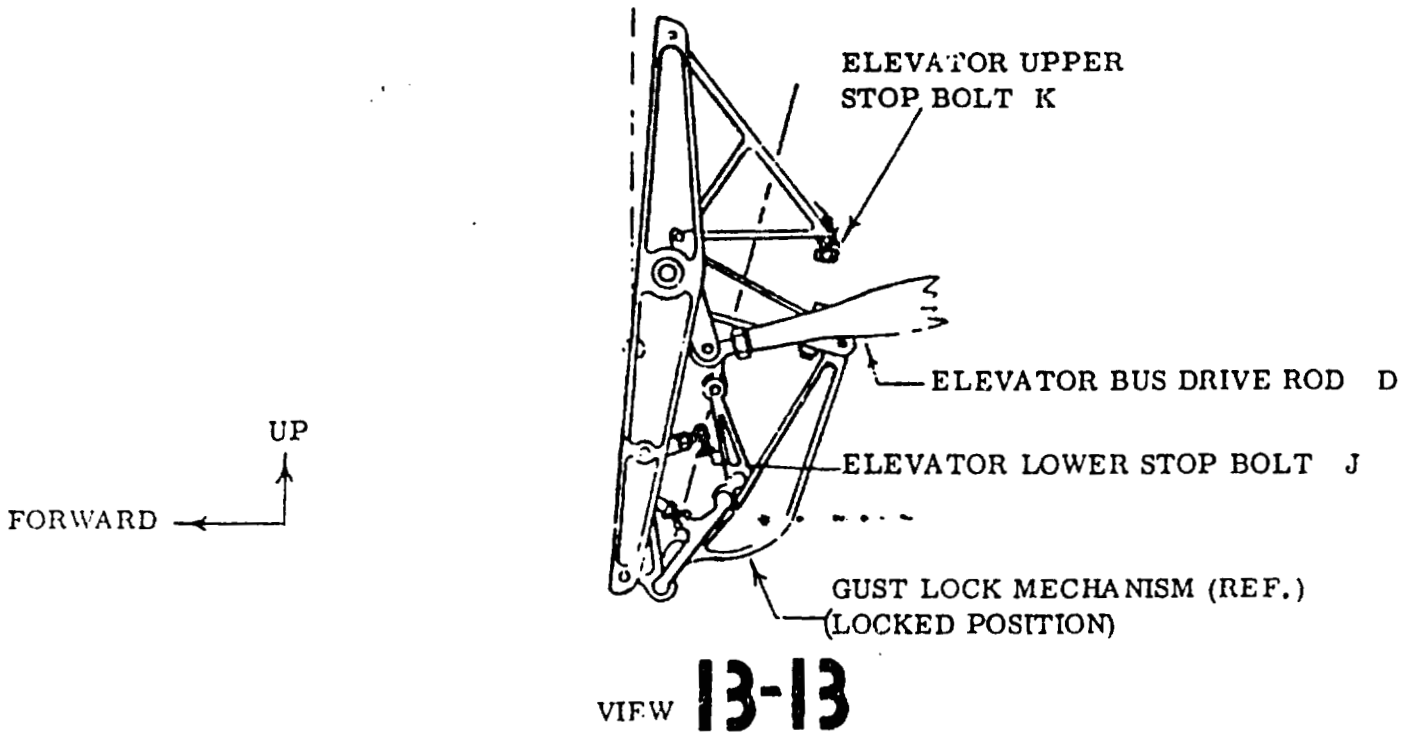

FIGURE 201 (SHEET 3 OF 3) - ELEVATOR CONTROL SYSTEM

3

TMA 4761/C/1161N

EFF: DC8-71 N8070U-99U
N8177U

DC8MM

CONTINUED

27-30-03

Page 208

Jan 30/86